

HIGH PERFORMANCE **SEALING** SOLUTIONS

CATALOGUE



Schlegel

TYMAN group

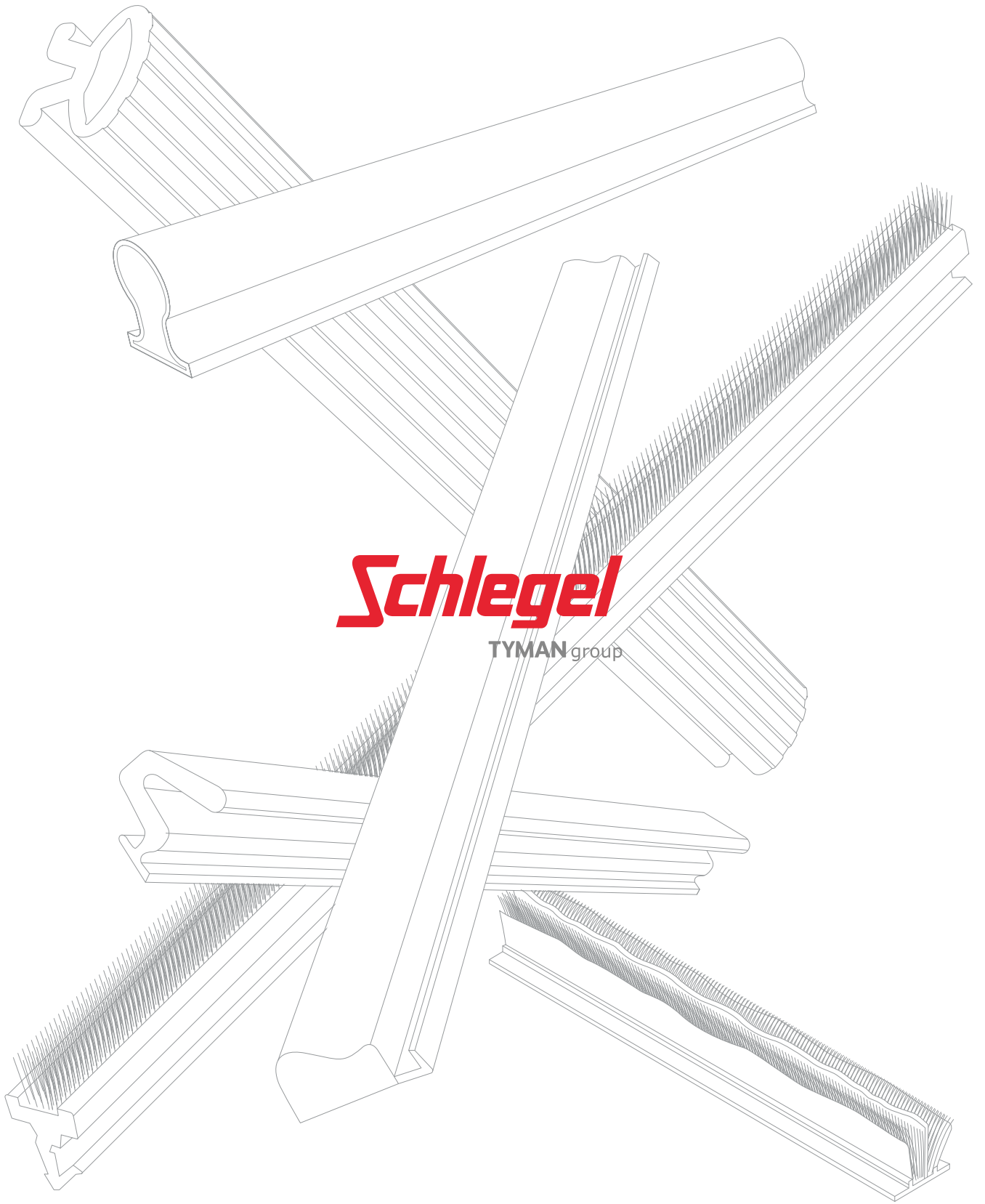

Schlegel

TYMAN group

Table of Contents

The company

Quality products	04
Selecting a seal	05
The product range	06
Tyman International	07
Conformity to CE marking 2016	08
Other relevant standards	09

Q-LON: polyurethane foam seals

For timber, aluminium and PVC applications

Materials and colours	12
Thermal conductivity	15
Classifications	16
Performance tables	17
Range overview	18
Certifications	23
Other certifications	24
Technical specifications	
Universal. Application on all surfaces	26
Interior design. Applications on timber doors and windows	28
Timber. Window applications	36
Aluminium. Door and window applications	42
PVCu. Door and window applications	46
Accessories	50
Instructions	51
Tools	51

Brush pile seals and sealing profiles

For timber, aluminium and PVC applications

Materials and colours	51
Selector	57
Certifications	58
Quality control	61

Technical specifications

Brush pile seals	62
Poly-Bond (PB): woven brush pile seals	63
Fin-Seal (FS): woven brush pile seals	64
Dust-Plug (DP): woven brush pile seals	65
Shutter-Pile (SP): woven brush pile seals	66
Power-Pile (PW): extruded brush pile seals	67
Fin-Pile (FP): extruded brush pile seal	68
G3: extruded brush pile seals	69
G3-QF (Quadrafin): extruded brush pile seals	70
Bi-Fin (BF): extruded brush pile seals	71
Angle-Pile (AP): extruded brush pile seals	72
Skirting-Fringe (SF): extruded brush pile seals	73
Flex-Brush (FB): coilable brush pile seals	74
Kerf-Pile (KP): extruded brush pile seals	75
Combination brush pile seals	76
For universal surface fitting	77
For kerf-slot fitting	77
Carriers for brush pile seals	78

Extruded seals

For timber, aluminium and PVC applications

Materials and colours	82
Classifications	85
Technical specifications	
Lozaron. Extruded profiles for timber doors and windows	86
Lozaron. Extruded profiles for aluminium doors and windows	88
Shutters and screens	92



The company

Schlegel was founded in Rochester, USA, in 1885 as a textile company. In 1930, it began producing brush seals and sealing profiles for buildings, before introducing foam seals in the 1960s.

In 2013 Schlegel joined the **Tyman** group, an international supplier of access components and solutions to the construction industry, with a marketing network that extends to customers in over 100 countries worldwide. The group is listed on the London Stock Exchange.

Quality products

Schlegel has an unrivalled reputation for high quality, service and technical innovation. The company has established itself as a world leader in the manufacture of seals, weatherstrips, gaskets and extrusions.

All products are manufactured to meet the requirements of current and proposed British, European and International Standards and are manufactured using a Quality Management System registered and certified to BS EN ISO 9001:2015 Quality Systems.

European standards require all components of each window and door to be tested with a view to constant functional quality, regardless of the type of product and the profile on which it is applied.

Each component is subjected to internal testing to verify its actual performance level or directly certified by institutes authorised to the highest levels required by the regulations (i.e. IFT Z-CERT QM338). The auditors of these institutes perform a periodic review of the effectiveness of the production plant control in order to ensure continual quality improvement. All the raw materials (polypropylene, TPE, PVC, polyurethane, etc.) are subjected to chemical composition checks that guarantee constant performance as required by the reference standards.

ISO 9001 certified
ISO 14001 certified



Selecting a seal material and design

The selection of a suitable seal product is dependent on the performance characteristics required for the door, window, skylight, shutter or curtain wall in the application for which it has been designed.

A great deal of guidance can be gained from the classification under EN 12365-1 2003, which should always be checked.

For thermal conductivity of the seal as an element of the overall construction of the window or door,

reference can be made to table 1 of EN 12524 2000 or by direct calculation.

Schlegel can support all product design, manufacturing and installation teams with the specification and supply of a seal to meet their specific application requirements, and to support compliance with the required product standards.

The product range

Materials, technologies and designs

In order to cover all normal applications for windows, doors, shutters and curtain walling, Schlegel offers the widest range of weatherstripping materials and technologies available.



Q-LON polyurethane foam weatherseals

A combination of polyurethane, polypropylene (or polycarbonate) insert and polyethylene liner makes Q-LON one of the best weatherseals in the world. Suitable for timber, PVC and aluminium windows and doors in compression and sliding applications.

Polypropylene brush pile seals

Primarily for sliding applications, pile weatherseals are produced in a number of formats to suit varying performance and application requirements.



Extruded seals

Extruded weatherseals designed to meet specific needs for timber, PVC and aluminium framed windows and doors. Products can include variable hardness and foam TPE elements to deliver superior performance.

Q-LON

Brush pile

Extruded

Tyman International is a division of the Tyman group, leading international supplier of engineered fenestration components and access solutions, whose commercial network reaches clients in over one hundred countries in the world. The Group is listed on the London Stock Exchange.

Tyman International products are sold in over 80 territories across the globe under the Schlegel, Giesse, Reguitti and Jatec brands. The company has distribution facilities in Spain, Greece, United Arab Emirates, India, Argentina and Australia.

GIESSE

Innovative Engineered Hardware

Solutions and hardware for aluminium windows and doors

Since 1965, Giesse is the brand that opens up new frontiers on hardware for aluminium windows and doors. Technical innovation and top quality are at the core of the business. From design to production and certification, Giesse is a trusted partner that provides cutting-edge solutions for the fenestration industry.

REGUITTI

Italian Design Handles

Architectural door and window handles

Since 1975, Reguitti handles and accessories have been designed with a focus on natural harmony, the new and the unconventional. A vision that combines functionality and aesthetics.

JATEC

Timeless Exclusive Handles

Handles and complements for windows and doors

Created in 1890, Jatec (formerly JADO) has evolved from producing fittings for leather cases to exclusively focusing on windows and doors handles by 1975. Jatec is today one of the leading manufacturers in the market of premium handles for interior design.

168
Million euros in annual revenue
(2022)

15
Units

5
Production facilities

+800
Employees

+100
Markets around the world

+150
Patents

CE conformity

Enabling a window or door to meet the requirements for CE marking 2016

The Construction Products Regulation came into force on 1st July 2013, and requires that manufacturers, who place construction products covered by a harmonised European standard on the market within the European Economic Area (EEA), apply a CE mark and produce a Declaration of Performance (DOP) for their products.

CE marking is not applied to windows and doors in all applications in all countries across Europe, but still provides consumers with the confidence in the performance of the products they purchase. In order to CE mark a window or a door, the manufacturer is reliant on their component suppliers to provide declarations of performance to support their claims.

As already mentioned, weatherstrips and gaskets are critically important in the performance of the installed window and therefore door and window manufacturers must choose components from suppliers capable of demonstrating and certifying that the required standards are met or even exceeded.

All external windows and doors across Europe must meet the performance requirements of EN 14351-1 2016. A suitable gasket and/or weatherstrip is an essential component in meeting these performance requirements.

The standard requires that all sellers of complete window, door, shutter and curtain walling assemblies make certain declarations on the performance of their products. In most countries this is done in the form of a CE (Conformité Européenne) mark. This relates to weatherstrips and gaskets in two main ways:

- That the materials they are made from are not hazardous in terms of the emission and/or migration of dangerous substances as required by EN 14351-1 2016 clause 4.6.
- That the seal meets the performance requirements under EN 12365-1 2003 as required by EN 14351-1 2016 clause 4.15.

The ultimate method of demonstrating performance compliance is to practically test each window and door in all relevant configurations with the specified components.

This may not be practical in all cases but EN 12365 2003 provides a method by which the relative performance of different weatherstrips and gaskets may be assessed and compared. Window and door manufacturers should also note that...

...a further requirement of clause 4.15 is that weatherstrips or gaskets should be replaceable...

...to ensure the long term serviceability of the door or window. Compliance can normally be demonstrated by ensuring that the seal is located in a pocket or kerf slot in the profile and can therefore be removed and replaced.

Schlegel Products

To help establish compliance with EN 14351-1 2016, your seal manufacturer needs to make some compliance declarations. Here are the declarations for Schlegel products.

Compliance with clause 4.6: Dangerous substances

In accordance with the requirements of Annex I of regulation No. 305/2011 of the European Parliament and clause 4.6 (Dangerous Substances) of EN 14351-1 2016 + A1: 2010, we confirm that there are no materials liable to emission or migration during the normal intended use of products supplied by SchlegelGiesse, that are potentially dangerous to hygiene, health or the environment.





Q-LON

Brush pile

Extruded

CE

Compliance with clause 4.15: Durability

In accordance with clause 4.15, the long term water tightness and air permeability characteristics of an external door, window or roof light are dependent upon the weatherseals.

This clause requires that weather seals comply with the relevant European standard, in this instance, EN 12365-1 2003 (Building hardware. Gasket and weather stripping for doors, windows, shutters and curtain walling. Performance requirements and classification).

Other relevant standards

There are a number of other European standards that cover more general requirements of windows and doors as a whole in specific areas of performance. These should be referred to separately.

EN 12207 2000 – Air Permeability

EN 12208 2000 – Water Tightness

EN 12567 2000 – Thermal Conductivity

EN 13115 2001 – Operating Forces

EN ISO 10140-2 – Acoustic Performance

Q-LON

Polyurethane foam seals

For timber, aluminium
and PVC applications



Index

Materials and colours	12
Thermal conductivity	15
Classifications	16
Performance tables	17
Range overview	18
Certifications	23
Other certifications	24
Technical specifications	
Universal. Application on all surfaces	26
Interior design. Applications on timber doors and windows	28
Timber. Window applications	36
Aluminium. Door and window applications	42
PVCu. Door and window applications	46
Accessories	50
Instructions	51
Tools	51

Materials and colours

The unique Q-LON seal is made from a special polyurethane foam, contained in a weather resistant polyethylene liner.

Foam

Polyurethane (PU) foam core

High durability, superior recovery performance.

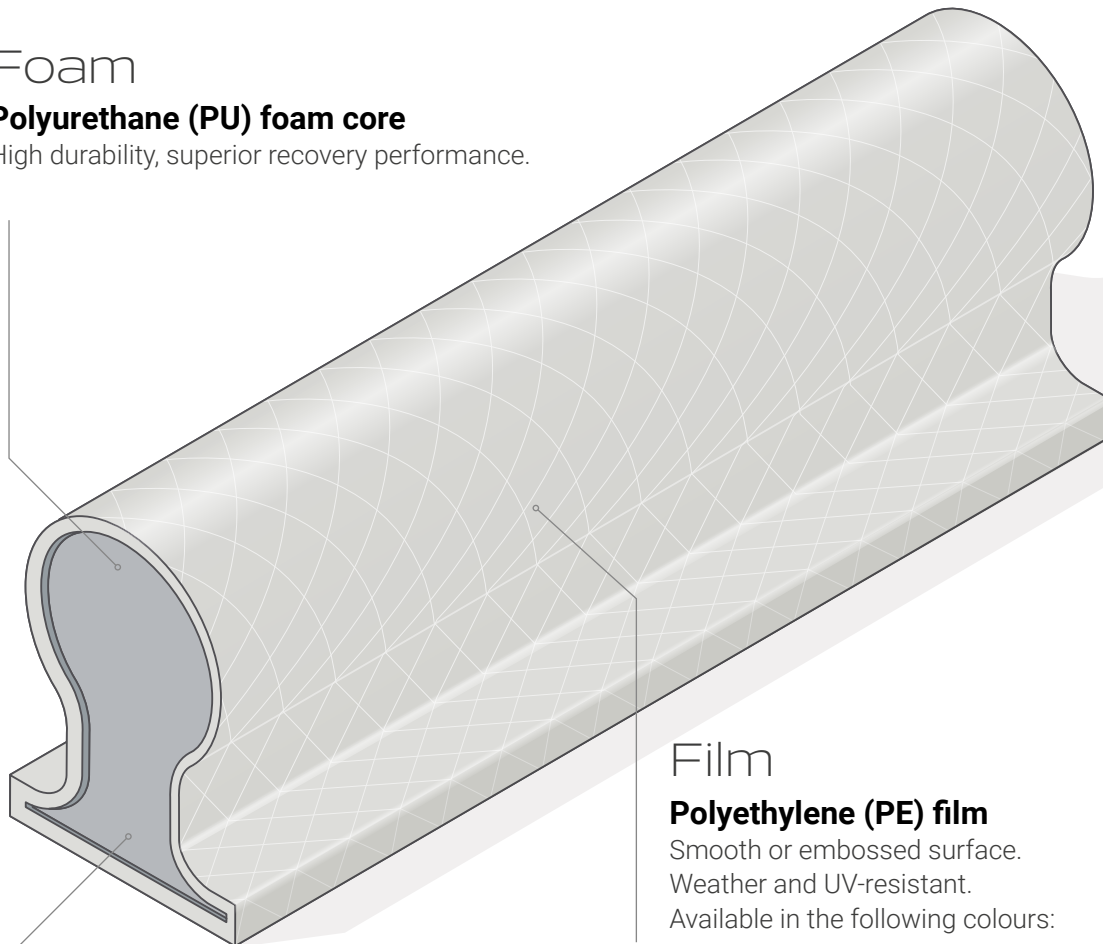

Film

Polyethylene (PE) film

Smooth or embossed surface.

Weather and UV-resistant.

Available in the following colours:

Standard Colours

- WHITE / RAL 9003 / Code 222
- SILVER / RAL 7001 / Code 212
- BROWN / RAL 8019 / Code 220
- BLACK / RAL 9005 / Code 223

Extra Colours

- BEIGE / RAL 1001 / Code 211
- LIGHT OAK / RAL 8003 / Code 217
- FAWN BROWN / RAL 8007 / Code 218
- PURE WHITE / RAL 9010 / Code 221
- LIGHT GREY / RAL 7035 / Code 215
- PEBBLE GREY / RAL 7032 / Code 252
- GRAPHITE GREY / RAL 7024 / Code 214

Insert

Polypropylene (PP), polycarbonate or with glass fibre cord

Prevents elongation and shrinkage.

EVERLASTING

The **external polyethylene film** is not altered by paints, detergents or dyes. Its high resistance to atmospheric conditions and UV radiation ensures that Q-LON **lasts three times longer*** than the most common foam seals.

Schlegel
TYMAN group

VERY LOW THERMAL CONDUCTIVITY

Q-LON polyurethane seals offer the **lowest thermal conductivity** on the market (**0.04 W/m·K at 0°C**), 3 to 6 times better than other materials.

Schlegel
TYMAN group

*Test performed in accordance with EN 12667:2001 standard in comparison with extruded gaskets

Thermal conductivity

To EN ISO 10077-1 2006 and EN 12524 2012

The unique Q-LON seal is made from a special polyurethane foam, contained in a weather resistant polyethylene liner.

Thermal conductivity

Section 4.12 of EN 14351-1 2006 stipulates the methods for determining thermal transmittance of windows and doors that can be used for EC Declarations of Performance. Common window configurations can use standard tables within EN 10077-1 2006 for declared thermal performance values, though more accurate values can be obtained by individual calculation or hot box testing. In accordance with 4.12 of EN 14351-1, calculations used for declaring thermal transmittance should be conducted in accordance with the methodology stipulated in EN ISO 10077-1 2006 and EN ISO 10077-2 2012. EN ISO 10077-2 2012 details the process for the calculation of frame element of windows, and doors, including weather seals and gaskets. For thermal calculations, it is necessary to understand the linear thermal transmittance, or thermal conductivity, of the individual frame component materials. Section 5.1 of EN ISO 10077-2 2012 refers to a further standard, EN ISO 10456 2007, as a suitable source of tabulated performance values for a variety of building materials.

Which seal has the lowest conductivity?

Table 3 of EN ISO 10456 2007 details polyurethane foam weather seals with a linear thermal transmittance of 0.05 W/(m.K). This should be the value used for Q-LON seals within window and door specifications, when calculating thermal performance declarations in compliance with the requirements of EN 14351-1 2006.

The material performance values within **Table 1 of EN ISO 10456 2007** also highlight the superior thermal performance of Q-LON.

There is a proverb that says: a chain is only as strong as its weakest link. This also applies to the fenestration industry. Doors and windows only perform as well as the seal. The thermal performance that can be achieved by a window or door is determined by many different factors.

The composition of the frame material and the glass are both very important. A low quality seal, however, can easily spoil the energy saving effects of insulated profiles and argon filled HR glass. Under EN ISO 10456:2007, the design thermal conductivity of different materials used for seals is detailed thus:

- EPDM 0.25 W/(m·K)
- PVC 0.14 W/(m·K)
- PU 0.05 W/(m·K)

In accordance with EN 12667 (Thermal performance of building materials and products - Determination of thermal resistance by means of guarded hot plate and heat flow meter methods), it now has been independently tested and certified by ift Rosenheim: Q-LON has a measured low thermal conductivity of **just 0.04 W/(m·K)**.

This is better than any other weather seal available in the market. Compared to other seals, energy loss is minimised. In combination with an excellent high compression recovery (on average higher than 90%) a high performance is also guaranteed over the long term.

Evidence of Performance		Thermal conductivity (declared value)	
Test Report No. 15-003940-PR01 (PB-K03-06-en-02)			
Client	SCHLEGEL GERMANY GMBH Bredowstr. 33 22113 Hamburg Germany	Basis *)	EN 12667:2001-01 EN ISO 10456 2009-12
Product	Flexible polyurethane foam boards Designation: *Q - Lon Platten*	Test report 15-003940-PR01 (PB-K03-06-de-03) dated 23.07.2016	*) Equivalent national versions (e.g. DIN EN)
Performance-relevant product details	Dimensions, width x height in mm: approx. 255 x 255 ; Material: Flexible polyurethane foam based on polyol, both sides with polyethylene facing / 95 µm ; Foaming agent: water / carbon dioxide ; Density in kg/m ³ : 125 to 136 ; Closed pore structure: open pores ; Application: seals for windows, doors	Representation	
Conditioning	After delivery, the test specimens were conditioned at 23 °C / 50 % relative humidity until achieving constant mass (0.1 % / 24 h).	Instructions for use	The test report serves to demonstrate the thermal conductivity (declared value) λ _D .
Special features	The test specimens were characterised by unevenness resulting from the manufacturing process.	Validity	The data and results given refer solely to the tested and described specimen. This test!
Results	Thermal conductivity (declared value) $\lambda_D = 0.041 \text{ W/(m} \cdot \text{K)}$ *		
	* The thermal conductivity was determined at an average temperature of 10°C.		

Classifications

Of weatherseals according to EN 12365 2003

Under EN 12365 2003 there is a prescribed classification system that enables window, door, shutter and curtain walling manufacturers or installers to ensure that they are using the component that best meets their requirements.

A six-digit system is used

1	2	3	4	5	6
Category of use	Working range	Linear compression force	Working temperature range	Deflection recovery	Recovery after ageing
W = Weatherstrip G = Gasket	9 grades showing the working range of the seal; 9 indicates the greatest distance	9 grades showing the linear compression force; 9 indicates the greatest force	6 grades showing the working temperature range, Each with different high and low temperatures	8 grades showing deflection recovery; grade 0 indicates no requirement and grade 7 shows the greatest recovery	8 grades showing recovery after ageing; grade 0 indicates no requirement and grade 7 shows the greatest recovery

Grades

	1: ≤ 1 mm 2: >1 mm ≤ 2 mm 3: >2 mm ≤ 4 mm 4: >4 mm ≤ 6 mm 5: >6 mm ≤ 8 mm 6: >8 mm ≤ 10 mm 7: >10 mm ≤ 15 mm 8: >15 mm ≤ 30 mm 9: >30 mm	1: ≤ 10 N/m 2: >10 N/m ≤ 20 N/m 3: >20 N/m ≤ 50 N/m 4: >50 N/m ≤ 100 N/m 5: >100 N/m ≤ 200 N/m 6: >200 N/m ≤ 500 N/m 7: >500 N/m ≤ 700 N/m 8: >700 N/m ≤ 1000 N/m 9: >1000 N/m	1: 0°C to +45°C 2: -10°C to +55°C 3: -20°C to +85°C 4: -25°C to +100°C 5: -40°C to +70°C 6: 0°C to +200°C	0: No requirements 1: >30% to 40% 2: >40% to 50% 3: >50% to 60% 4: >60% to 70% 5: >70% to 80% 6: >80% to 90% 7: >90%	0: No requirements 1: >30% to 40% 2: >40% to 50% 3: >50% to 60% 4: >60% to 70% 5: >70% to 80% 6: >80% to 90% 7: >90%
--	--	--	--	---	---

A typical classification looks like this

W	4	3	2	7	6
---	---	---	---	---	---

Q-LON consistently delivers the highest levels of performance

Deflection recovery	Recovery after ageing
---------------------	-----------------------



Performance tables

The methodology for the linear compression test, the deflection recovery test and the recovery after ageing test are all described in EN 12365 2003 parts 2, 3 and 4.

The Schlegel testing facilities in Aycliffe are accredited by ift Rosenheim.

Q-LON classification to EN 12365 2003

QL 1026	W	2	6	2	7	6	QL 3106	W	2	5	2	7	6	QL 57700	W	2	5	2	6	6
QL 1032	W	3	5	2	7	6	QL 3109	W	4	3	2	7	6	QL 5878	W	2	5	2	4	6
QL 3004	W	2	6	2	7	6	QL 3110	W	2	5	2	6	6	QL 60	W	3	5	2	7	6
QL 3005	W	3	5	2	6	6	QL 3111	W	3	5	2	5	6	QL 6571	W	3	5	2	6	6
QL 3006	W	6	2	2	7	6	QL 3113	W	3	5	2	6	6	QL 6750	W	3	4	2	6	6
QL 3009	W	3	2	2	6	6	QL 3116	W	3	4	2	6	6	QL 69400	W	1	5	2	5	6
QL 3011	W	3	5	2	7	6	QL 3117	W	2	3	2	6	6	QL 69510	W	1	5	2	4	6
QL 3012	W	4	5	2	7	6	QL 3118	W	3	1	2	7	6	QL 69650	W	1	5	2	6	6
QL 3013	W	1	5	2	7	6	QL 3121	W	3	2	2	6	6	QL 69700	W	3	3	2	7	6
QL 3020	W	4	4	2	6	6	QL 3122	W	1	7	2	7	6	QL 69750	W	2	4	2	6	6
QL 3025	W	2	5	2	6	6	QL 3124	W	1	6	2	7	6	QL 69800	W	3	4	2	6	6
QL 3034	W	3	6	2	7	6	QL 3126	W	1	7	2	7	6	QL 6991	W	2	5	2	6	6
QL 3037	W	3	5	2	6	6	QL 3128	W	3	2	2	6	5	QL 69950	W	3	4	2	6	6
QL 3042	W	2	4	2	7	6	QL 3131	W	2	5	2	6	6	QL 7000	W	5	2	2	6	6
QL 3053	W	3	5	2	6	6	QL 3138	W	2	5	2	7	6	QL 70012	W	3	2	2	6	6
QL 3054	W	3	5	2	7	6	QL 3139	W	3	1	2	7	6	QL 70013	W	3	2	2	6	6
QL 3056	W	3	4	2	7	5	QL 3140	W	3	5	2	6	6	QL 70014	W	3	4	2	7	6
QL 3059	W	3	3	2	6	5	QL 3141	W	3	5	2	5	5	QL 7032	W	3	4	2	6	6
QL 3061	W	3	3	2	6	6	QL 3141	W	2	4	2	5	5	QL 7066	W	3	3	2	6	6
QL 3063	W	3	6	2	6	6	QL 3143	W	2	6	2	7	5	QL 7307	W	3	5	2	7	6
QL 3067	W	3	5	2	7	6	QL 3147	W	3	4	2	6	6	QL 836	W	3	3	2	6	6
QL 3068	W	3	5	2	7	5	QL 3150	W	3	3	2	6	6	QL 9005	W	2	4	2	6	6
QL 3070	W	2	5	2	6	6	QL 3151	W	3	3	2	6	6	QL 9100	W	3	5	2	7	6
QL 3072	W	2	4	2	6	5	QL 3152	W	3	3	2	6	6	QL 9111	W	3	4	2	6	6
QL 3073	W	4	4	2	7	5	QL 4465	W	2	5	2	6	6	QL 9112	W	3	5	2	7	6
QL 3074	W	2	6	2	7	6	QL 45	W	2	7	2	7	6	QL 9154	W	3	5	2	6	6
QL 3076	W	3	4	2	6	6	QL 46105	W	3	6	2	7	6	QL 9171	W	2	5	2	6	6
QL 3078	W	3	3	2	6	6	QL 46800	W	2	5	2	6	6	QL 9257	W	3	3	2	7	6
QL 3079	W	2	4	2	6	6	QL 48400	W	1	6	2	6	6	QL 9489	W	2	6	2	7	6
QL 3082	W	3	5	2	7	5	QL 48510	W	1	5	2	5	6	QL 9536	W	4	3	2	7	6
QL 3091	W	4	4	2	6	5	QL 48650	W	2	5	2	5	6	QL 9596	W	2	6	2	7	6
QL 3093	W	4	4	2	6	6	QL 4870	W	2	3	2	6	6	QL 9646	W	3	5	2	7	6
QL 3094	W	3	2	2	6	5	QL 48700	W	3	3	2	7	6	QL 9608	W	3	3	2	7	6
QL 3095	W	3	2	2	7	5	QL 48750	W	2	5	2	6	6	QL 9613	W	3	3	2	7	6
QL 3096	W	3	3	2	6	5	QL 48800	W	3	4	2	7	6	QL 9688	W	3	3	2	7	6
QL 3097	W	3	5	2	6	6	QL 48950	W	3	4	2	6	6	QL 9898	W	3	5	2	7	6
QL 3098	W	3	3	2	6	6	QL 50	W	2	5	2	7	6	QL 9926	W	3	3	2	7	6
QL 3099	W	3	3	2	6	6	QL 55	W	2	5	2	6	6	QL 9928	W	3	4	2	7	6
QL 3101	W	3	5	2	7	6	QL 5570	W	2	4	2	6	6	QL 9985	W	3	5	2	7	6
QL 3102	W	3	3	2	6	6	QL 5626	W	3	3	2	5	6							
QL 3104	W	4	4	2	7	5	QL 5694	W	4	3	2	6	6							

Range overview

Universal surface fitting

Code	Dimensions (mm)			
	Seal		Application	
	Width	Height	Rebate	Seal gap
Taped				
QL 1026	12.0	4.0	12.0	1.0 - 3.0
QL 1032	12.0	7.0	12.0	2.0 - 6.0
QL 3116	10.8	8.7	11.0	3.0 - 5.5
QL 3117	11.2	6.5	11.0	3.0 - 5.5
QL 3121	15.0	12.0	15.0	5.0 - 10.0
QL 3122	7.0	2.2	7.0	0.5 - 2.0
QL 3124	6.4	3.7	6.0	2.5 - 3.5
QL 3126	10.0	3.0	10.0	1.0 - 2.5
QL 9171	8.0	6.0	8.0	4.5
Untaped				
QL 3042	11.2	6.5	11.0	3.0 - 5.5
QL 3059	10.8	8.7	11.0	3.0 - 5.5
QL 3061	15.0	12.0	15.0	5.0 - 10.0
QL 9171	8.0	6.0	8.0	4.5

Interior design (timber doors and furniture)

Code	Dimensions (mm)			
	Groove		Rebate	Seal gap
	Throat width	Min. depth		
QL 50	2.7 - 3.0	6.0	10.0	3.0 - 5.0
QL 55	2.7 - 3.0	6.0	10.0	3.0 - 4.5
QL 60	2.7 - 3.0	6.0	10.0	3.0 - 4.5
QL 3037	2.7 - 3.0	6.0	10.0	3.5 - 5.6
QL 3056	2.7 - 3.0	6.0	9.0	4.0 - 7.5
QL 3072	2.7 - 3.2	6.5	10.0	2.7 - 4.3
QL 3091	4.0 - 5.0	7.5	15.0	4.0 - 8.0
QL 3094	2.7 - 3.2	6.5	10.0	3.0 - 6.0
QL 3097	4.0 - 5.0	7.5	18.0	3.5 - 6.0
QL 3100	3.5 - 4.0	6.5	12.0	4.0 - 7.5
QL 3106	3.5 - 4.0	6.5	12.0	3.0 - 5.0
QL 3110	3.5 - 4.0	6.5	12.0	3.5 - 4.0
QL 3113	3.5 - 4.0	7.0	12.0	4.0 - 7.5
QL 3138	2.7 - 3.2	6.0	8.0	3.0 - 4.5
QL 9985	2.7 - 3.0	6.0	10.0	3.0 - 6.5
QL 70014	4.0	7.0	8.0	4.1 - 7.0

Interior design (timber doors and furniture)

Location	Dimensions (mm)		
	Groove		Seal gap
	Throat width	Depth	
QL 3006	2.7 - 3.0	6.0	5.0 - 13.0
QL 3009	2.7 - 3.0	6.0	4.0 - 7.5
QL 3011	2.7 - 3.0	6.0	3.5 - 5.5
QL 3012	2.7 - 3.0	6.0	4.0 - 6.5
QL 3013	2.7 - 3.0	6.0	2.0 - 3.0
QL 3034	2.7 - 3.0	8.0	0.0 - 1.5
QL 3070	2.7 - 3.0	8.0	0.0 - 1.5
QL 3073	4.0 - 5.0	7.5	5.0 - 8.0
QL 3074	2.7 - 3.2	6.5	3.5 - 5.5
QL 3077	2.7 - 3.0	6.0	2.0 - 3.0
QL 3078	3.0 - 3.3	6.0	4.0 - 7.5
QL 3079	3.2 - 4.0	6.5	2.7 - 4.3
QL 3093	2.7 - 3.0	7.0	4.0 - 8.0
QL 3095	3.5 - 4.0	6.5	3.0 - 6.0
QL 3096	4.0 - 5.0	7.5	3.0 - 6.0
QL 3098	3.0 - 4.0	7.5	3.0 - 6.0
QL 3099	3.0 - 3.3	6.0	4.0 - 7.5
QL 3102	3.7 - 4.2	7.0	5.0 - 7.5
QL 3104	4.0 - 5.0	7.5	5.0 - 9.0
QL 3109	4.0 - 5.0	7.0	5.0 - 9.0
QL 3118	3.0 - 3.3	7.0	3.0 - 7.5
QL 3128	2.7 - 3.0	7.0	4.0 - 7.5
QL 3131	2.7 - 3.0	8.0	0.0 - 1.5
QL 3139	2.7 - 3.0	7.0	4.0 - 7.5
QL 5626	2.7 - 3.0	6.0	4.7 - 7.5
QL 5694	2.7 - 3.0	6.0	6.0 - 11.0
QL 7000	2.7 - 3.0	6.0	4.0 - 10.8
QL 7066	2.7 - 3.0	6.0	4.8 - 7.7
QL 9111	3.0 - 3.3	6.0	4.8 - 7.9
QL 9480	2.7 - 3.0	6.0	3.5 - 7.0

Timber windows

Code	Dimensions (mm)			
	Groove		Rebate	Seal gap
	Throat width	Min. depth		
Centre seal				
QL 3053	4.0 - 5.0	7.5	12.0	4.5 - 6.0
QL 3063	4.0 - 5.0	7.5	12.0	5.5 - 7.5
QL 3067	4.0 - 5.0	7.5	12.0	4.0 - 6.0
QL 3068	3.4 - 4.2	6.5	11.0	4.5 - 6.5
QL 3072	2.7 - 3.2	6.5	10.0	2.7 - 4.3
QL 3076	3.0 - 3.5	6.0	10.0	3.0 - 6.0
QL 3079	3.2 - 4.0	6.5	10.0	2.7 - 4.3
QL 3101	2.7 - 3.2	7.0	13.0	3.5 - 6.0
QL 3111	3.5 - 4.0	7.0	12.0	3.5 - 4.0
QL 3140	4.0 - 5.0	7.5	15.0	4.0 - 6.5
QL 3141	2.7 - 3.2	5.5	12.0	4.0 - 6.5
QL 3147	3.0 - 3.5	6.0	10.0	3.0 - 6.0
Overlap seal				
QL 3034	2.7 - 3.0	8.0	8.5	0.0 - 1.5
QL 3054	2.8 - 3.2	5.5	10.0	4.0 - 6.0
QL 3070	2.7 - 3.0	8.0	8.0	0.0 - 1.5
QL 3097	4.0 - 5.0	7.5	18.0	3.5 - 6.0
QL 3131	2.7 - 3.0	8.0	8.0	0.0 - 1.5
QL 3141	2.7 - 3.2	5.5	12.0	4.0 - 6.5
Frame seal				
QL 3004	2.7 - 3.0	6.0	10.5	3.0 - 5.0
QL 3005	2.7 - 3.0	6.0	8.0	3.4 - 5.4
QL 3006	2.7 - 3.0	6.0	13.0	5.0 - 13.0
QL 3009	2.7 - 3.0	6.0	11.0	4.0 - 7.5
QL 3011	2.7 - 3.0	6.0	10.0	3.5 - 5.5
QL 3012	2.7 - 3.0	6.0	11.0	4.0 - 6.5
QL 3013	2.7 - 3.0	6.0	8.0	2.0 - 3.0
QL 3025	2.7 - 3.0	6.0	10.5	3.0 - 5.0
QL 3037	2.7 - 3.0	6.0	10.0	3.5 - 5.6
QL 3056	2.7 - 3.0	6.0	9.0	4.0 - 7.5
QL 3074	2.7 - 3.2	6.5	8.5	3.5 - 5.5
QL 3077	2.7 - 3.0	6.0	8.0	2.0 - 3.0
QL 3078	3.0 - 3.3	6.0	10.5	4.0 - 7.5
QL 3082	2.7 - 3.2	5.0	8.0	3.0 - 5.0
QL 3099	3.0 - 3.3	6.0	10.5	4.0 - 7.5
QL 3118	3.0 - 3.3	7.0	9.0	3.0 - 7.5
QL 3128	2.7 - 3.0	7.0	9.0	4.0 - 7.5
QL 3139	2.7 - 3.0	7.0	9.0	4.0 - 7.5
QL 3143	2.7 - 3.0	6.0	10.5	3.0 - 5.0
QL 5878	2.7 - 3.0	6.0	10.0	3.2 - 4.9
QL 9985	2.7 - 3.0	6.0	10.0	3.0 - 6.5

Aluminium windows and doors

Code	Dimensions (mm)		
	Location		Seal gap
	Throat width	Depth	
Type A (5.3 mm)			
QL 46105	3 - 3.2	2.3	5 - 5.5
QL 46800	2.6 - 3.2	2.3	3 - 3.5
QL 4636	3.2	2.3	1.0 - 2.5
QL 4870	3.2	2.3	2.5 - 4.0
QL 48100	3.2	2.3	5.5 - 7.0
QL 48400	3.2	2.3	0.5 - 2.0
QL 48510	3.2	2.3	1.1 - 2.4
QL 48650	3.2	2.3	1.8 - 3.4
QL 48700	3.2	2.3	2.5 - 6.0
QL 48800	3.2	2.3	2.5 - 7.0
QL 48750	3.2	2.3	2.7 - 4.6
QL 48950	3.2	2.3	4.0 - 6.5
QL 70013	3.2	5.3	4.5 - 8.5
Type B (6.3 mm)			
QL 57700	3.8	2.3	2.3 - 4.0
Type C (7.5 mm)			
QL 6970	4.6	2.3	2.5 - 4.0
QL 69100	4.6	2.3	5.5 - 7.0
QL 69400	4.6	2.3	0.5 - 1.5
QL 69510	4.6	2.3	1.1 - 2.4
QL 69650	4.6	2.3	1.8 - 3.4
QL 69700	4.6	2.3	2.5 - 6.0
QL 69750	4.6	2.3	2.7 - 4.6
QL 69800	4.6	2.3	2.5 - 7.0
QL 69950	4.6	2.3	4.0 - 6.5
QL 70012	4.6	7.5	4.5 - 8.5

PVCu windows and doors

Code	Dimensions (mm)	
	Location	Seal gap
	Throat width	
QL 4465	4.2	3.0 - 4.8
QL 5570	3.3	3.0 - 4.8
QL 6571	3.0	3.0 - 5.0
QL 6991	3.9	2.0 - 3.2
QL 7032	3.0	1.5 - 5.1
QL 7307	3.2	2.8 - 4.4
QL 9005	2.4	2.5 - 4.1
QL 9100	2.4	2.7 - 4.4
QL 9112	3.2	3.0 - 4.9
QL 9154	3.2	2.8 - 4.5
QL 9257	3.2	4.5 - 7.1
QL 9489	3.4	2.5 - 4.0
QL 9536	3.9	4.0 - 8.0
QL 9596	3.4	2.5 - 4.0
QL 9646	3.6	3.5 - 5.5
QL 9688	2.8	3.0 - 7.0
QL 9898	3.2	3.0 - 5.5
QL 9926	3.2 - 3.4	3.0 - 7.5
QL 9928	3.2 - 3.4	3.0 - 7.5

Q-LON

Brush pile

Extruded





FIRE RETARDANT

Seals classified to EN 13501-1, Class E, designed to reduce the spread of fire when in contact with it, slowing the speed of flames and avoiding the dispersion of flammable material.

Schlegel
TYMAN group

LOOKING AT THE FUTURE



Schlegel
TYMAN group



Certifications Cradle to Cradle

The construction industry is just one of many sectors that are adapting to meet the need for **more sustainable production processes** and more efficient use of resources.

The current transition towards a circular economy is driving **Schlegel** towards the use of materials and products free from chemicals that harm

people and the environment, without however reducing our high quality standards.

Sustainability certifications also hold important value in the market, especially since some countries have imposed mandatory environmental certification for specific products.



In 2020 Schlegel joined the certification programme led by the Cradle to Cradle Products Innovation Institute. This innovative initiative promotes sustainability by driving the transformation towards the design and production of products with a positive impact.

The Cradle to Cradle Certified® Products Programme is a multi-attribute, continuous improvement methodology that evaluates products across five categories of human and environmental health.

It evaluates products across five categories of human and environmental health. Each product is assigned a level for each category.

The standard encourages continuous improvement over time by awarding certification based on ascending levels of achievement.

Cradle to Cradle Certified® is recognised as a preferred product certification by many leading brands, organisations and sustainability standards. For Tyman International this is only the first step towards more ambitious goals.

Material health

Products are designed and developed through a process of inventorying, assessing and optimising chemical materials.

Circular economy

No more waste: products remain in a perpetual cycle of use and reuse.

Renewable energy & Carbon management

Products are manufactured using renewable energy.

Water stewardship

Since water is a valuable resource, watersheds are protected, leaving clean water available to people and all other organisms.

Social fairness

Business operations have to take into account all people and natural systems affected by a product manufacturing cycle.



Find out more about the **Cradle to Cradle®** certification system

Other certifications

EN 12365

Performance requirement and classification of gaskets for fenestration. Aiding in seal selection

Compression Set Testing

Based on EN 12365-4 Recovery after ageing at maximum working temperature.
For improved sealing life

UV Resistance

Accelerated weather test acc. to DIN EN ISO 4892-2 - Surface liner. Tests at: 2 GJ/m², 4 GJ/m² (6 GJ/m², 8 GJ/m²) for improved longevity

Thermal Conductivity

Tested to EN 12667:2001 ;D = 0.041 W/(m · K).
Low thermal transmittance supports improved window classification.

Komo

KOMO is the premier quality mark for the building and infrastructure sector in the Netherlands

Fire Retardant Version

Tested according EN 13501-1 Class E.
For Fire Rated doors.

Extreme Weather Resistance (Russian Standard)

TU5775-001-4900-1519-07.
Testing various properties and performance of seals at extreme climatic conditions - eg-60C





Code	Certification				
	EN 12365	KOMO	SKZ	Sintef	Cradle to Cradle
QL 1026	x	x			x
QL 1032	x	x			x
QL 3004	x	x			x
QL 3005	x	x		x	x
QL 3006	x	x			x
QL 3009	x	x			x
QL 3011	x	x			x
QL 3012	x	x			x
QL 3013	x	x		x	x
QL 3020	x	x			
QL 3025	x	x			x
QL 3034	x	x			x
QL 3037	x	x			x
QL 3042	x	x			x
QL 3053	x	x		x	x
QL 3054	x	x			x
QL 3056	x	x		x	x
QL 3059	x	x			x
QL 3061	x	x			x
QL 3063	x	x			x
QL 3067	x	x			x
QL 3068	x	x			x
QL 3070	x	x			x
QL 3072	x	x		x	x
QL 3073	x	x			x
QL 3074	x	x			x
QL 3076	x	x		x	x
QL 3077		x			x
QL 3078	x	x		x	x
QL 3079	x	x			x
QL 3082	x	x		x	x
QL 3091	x	x		x	x
QL 3093	x	x			x
QL 3094	x	x		x	x
QL 3095	x	x			x
QL 3096	x	x		x	x
QL 3097	x	x			x
QL 3098	x	x			x
QL 3099	x	x			x
QL 3101	x	x			x
QL 3102	x	x			x

Code	Certification				
	EN 12365	KOMO	SKZ	Sintef	Cradle to Cradle
QL 3104	x	x		x	x
QL 3106	x	x			x
QL 3109	x	x			x
QL 3110	x				x
QL 3111	x	x			x
QL 3113		x			x
QL 3116	x	x			x
QL 3117	x	x			x
QL 3118	x	x		x	x
QL 3121	x	x			x
QL 3122	x	x			x
QL 3124	x	x			x
QL 3126	x	x			x
QL 3128	x	x		x	x
QL 3131	x	x			x
QL 3138	x				x
QL 3139	x	x			x
QL 3140	x	x			x
QL 3141	x	x			x
QL 3143	x	x		x	x
QL 3147	x	x		x	x
QL 3150	x	x			
QL 3151	x	x			x
QL 3152	x				
QL 4465	x	x	x ¹		x
QL 45	x	x	x ¹		
QL 46105	x		x ¹		x
QL 46800	x		x ¹		x
QL 48400	x	x	x ¹		x
QL 48510	x	x	x ¹		x
QL 48650	x	x	x ¹		x
QL 4870	x	x	x ¹		x
QL 48700	x	x	x ¹		x
QL 48750	x	x	x ¹		x
QL 48800	x	x	x ¹		x
QL 48950	x	x	x ¹		x
QL 50	x	x			x
QL 55	x	x			x
QL 5570	x	x	x ¹	x	x
QL 5626	x	x			
QL 5694	x	x			x

Code	Certification				
	EN 12365	KOMO	SKZ	Sintef	Cradle to Cradle
QL 57700	x	x	x ¹		x
QL 5878	x	x	x ¹		x
QL 60	x	x			x
QL 6571	x	x	x ¹		x
QL 69400	x	x	x ¹		x
QL 69510	x	x	x ¹		x
QL 69650	x	x	x ¹		x
QL 69700	x	x	x ¹		x
QL 69750	x	x	x ¹		x
QL 69800	x	x	x ¹		x
QL 6991	x	x	x ¹		x
QL 69950	x	x	x ¹		x
QL 7000	x	x			x
QL 70012	x				
QL 70013	x				
QL 70014	x				
QL 7032	x	x	x ¹		x
QL 7066	x	x	x ¹		x
QL 7307	x	x	x ¹		x
QL 836	x	x	x ¹		x
QL 9005	x	x	x ¹		x
QL 9100	x	x	x ¹		x
QL 9111	x	x			x
QL 9112	x	x	x ¹		x
QL 9154	x	x	x ¹		x
QL 9171	x				
QL 9257	x	x	x ¹		x
QL 9480					
QL 9489	x	x		x	x
QL 9536	x	x	x ¹		
QL 9596	x	x	x ¹		
QL 9646	x	x	x ¹	x	x
QL 9608	x	x	x ¹		
QL 9613	x	x	x ¹		
QL 9688	x	x	x ¹		x
QL 9898	x	x	x ¹		x
QL 9926	x	x	x ¹		x
QL 9928	x	x	x ¹		x
QL 9985	x	x			x

¹Q-LON seal material was SKZ tested on the suitability for plastic windows in the colours white, silver grey and black

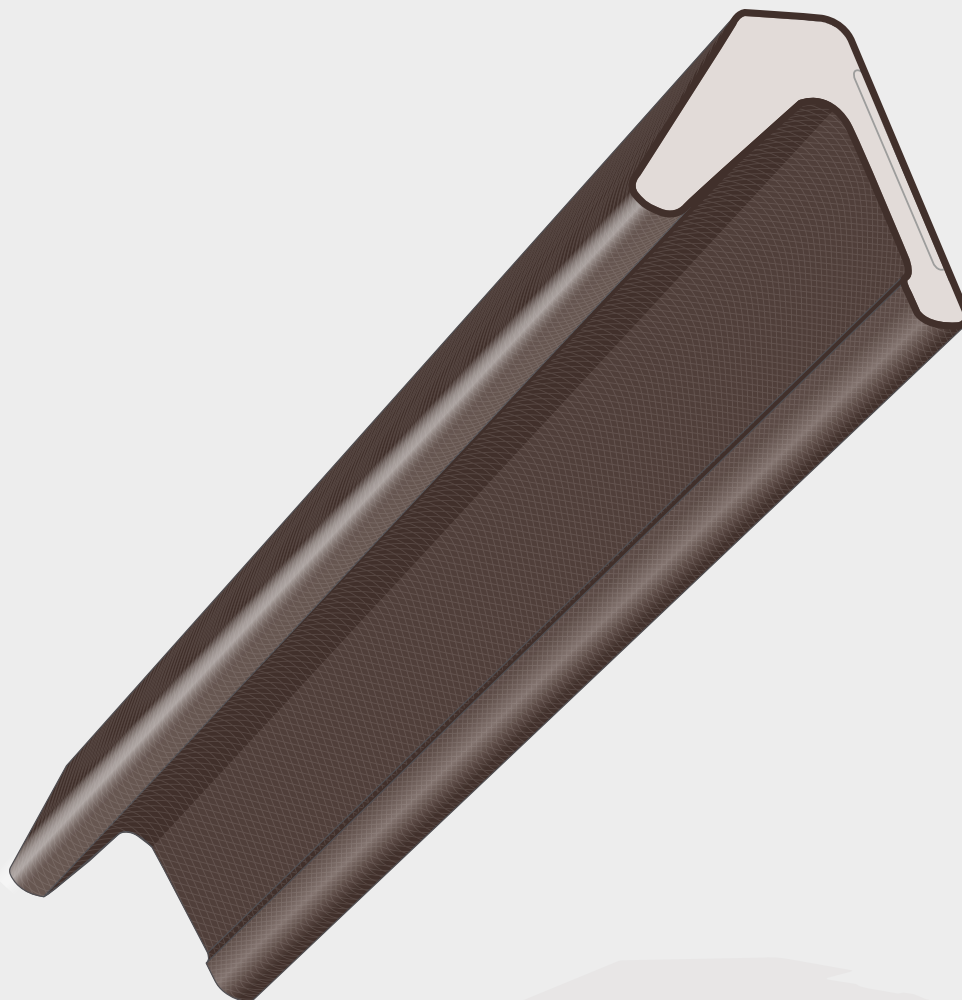

Universal

Application on all surfaces

Fixing with pre-applied adhesive tape.

Alternatively it can be fixed with adhesive tape, hot melt glue or staples.

QL 1026	2Q000	
Width: 12.0 Height: 4.0 Rebate: 12.0 Seal gap: 1.0 - 3.0 Pack size: 250 m x 2 500 m x 2		
Universal with adhesive		
W26276		
Cradle to Cradle Certified® Bronze		

QL 1032	2Q007	
Width: 12.0 Height: 7.0 Rebate: 12.0 Seal gap: 2.0 - 6.0 Pack size: 250 m x 2 500 m x 2		
Universal with adhesive		
W35276		
Cradle to Cradle Certified® Bronze		

QL 3042	2Q098
Width: 11.2 Height: 6.5 Rebate: 11.0 Seal gap: 3.0 - 5.5 Pack size: 400 m x 2	
Universal without adhesive	
W24276	
Cradle to Cradle Certified® Bronze	

QL 3059	2Q119
Width: 10.8 Height: 8.7 Rebate: 11.0 Seal gap: 3.0 - 5.5 Pack size: 300 m x 2	
Universal without adhesive	
W33266	
Cradle to Cradle Certified® Bronze	

QL 3061	2Q140
Width: 15.0 Height: 12.0 Rebate: 15.0 Seal gap: 5.0 - 10.0 Pack size: 250 m x 2	
Universal without adhesive	
W33266	
Cradle to Cradle Certified® Bronze	

QL 3116	2Q357
Width: 10.8 Height: 8.7 Rebate: 11.0 Seal gap: 3.0 - 5.5 Pack size: 300 m x 2	
Universal with adhesive	
W34266	
Cradle to Cradle Certified® Bronze	

QL 3117	2Q364
Width: 11.2 Height: 6.5 Rebate: 11.0 Seal gap: 3.0 - 5.5 Pack size: 400 m x 2	
Universal with adhesive	
W23266	
Cradle to Cradle Certified® Bronze	

QL 3121	2Q385
Width: 15.0 Height: 11.0 Rebate: 15.0 Seal gap: 5.0 - 10.0 Pack size: 225 m x 2	
Universal with adhesive	
W32266	
Cradle to Cradle Certified® Bronze	

QL 3121 FR	2Q386
Fire retardant	
Width: 15.0 Height: 11.0 Rebate: 15.0 Seal gap: 5.0 - 10.0 Pack size: 225 m x 2	
Universal with adhesive	
W32266	

QL 3122	2Q231
Width: 7.0 Height: 2.2 Rebate: 7.0 Seal gap: 0.5 - 2.0 Pack size: 200 m x 2	
Universal with adhesive	
W17276	
Cradle to Cradle Certified® Bronze	

QL 3124	2Q406
Width: 6.4 Height: 3.7 Rebate: 6.0 Seal gap: 2.5 - 3.5 Pack size: 1000 m x 2	
Universal with adhesive	
W16276	
Cradle to Cradle Certified® Bronze	

QL 3126	2Q413
Width: 10.0 Height: 3.0 Rebate: 10.0 Seal gap: 1.0 - 2.5 Pack size: 700 m x 2	
Universal with adhesive	
W17276	
Cradle to Cradle Certified® Bronze	

QL 9171	2Q840
Width: 8.0 Height: 6.0 Rebate: 8.0 Seal gap: 2.5 - 5.0 Pack size: 500 m x 2	
Universal with and without adhesive	
W25266	



Interior design

Applications on timber doors and windows



QL 45	2Q995	
Groove width: 3.0 Min. groove depth: 6.5 Rebate: 9.0 Seal gap: 2.0 Pack size: 250 m x 2		
Doors		

QL 836	2Q777	
Groove width: 3.0 - 3.2 Min. groove depth: 7.5 Seal gap: 5.0 - 7.5 Pack size: 125 m x 2		
Doors		
W15256		
Cradle to Cradle Certified® Bronze		

QL 50	2Q581	
Groove width: 2.7 - 3.0 Min. groove depth: 6.0 Rebate: 10.0 Seal gap: 3.0 - 5.0 Pack size: 250 m x 2		
Doors		
Cradle to Cradle Certified® Bronze		

QL 3009	2Q035	
Groove width: 2.7 - 3.0 Min. groove depth: 6.0 Rebate: 11.0 Seal gap: 4.0 - 7.5 Pack size: 250 m x 2		
Doors		F
W32266		
Cradle to Cradle Certified® Bronze		

QL 55	2Q595	
Groove width: 2.7 - 3.0 Min. groove depth: 6.0 Rebate: 10.0 Seal gap: 3.0 - 4.5 Pack size: 250 m x 2		
Doors		
W16266		
Cradle to Cradle Certified® Bronze		

QL 3011	2Q042	
Groove width: 2.7 - 3.0 Min. groove depth: 6.0 Seal gap: 3.5 - 5.5 Pack size: 250 m x 2		
Doors		
W35276		
Cradle to Cradle Certified® Bronze		

QL 55 FR	2Q597	
Fire retardant Groove width: 2.7 - 3.0 Min. groove depth: 6.0 Rebate: 10.0 Seal gap: 3.0 - 4.5 Pack size: 250 m x 2		
Doors		
W25266		

QL 3013	2Q210	
Groove width: 2.7 - 3.0 Min. groove depth: 6.0 Seal gap: 2.0 - 3.0 Pack size: 500 m x 2		
Doors		
W15276		
Cradle to Cradle Certified® Bronze		

QL 60	2Q644	
Groove width: 2.7 - 3.0 Min. groove depth: 6.0 Rebate: 10.0 Seal gap: 3.0 - 4.5 Pack size: 250 m x 2		
Doors		
W33266		
Cradle to Cradle Certified® Bronze		

QL 3020	2Q070	
Groove width: 2.7 - 3.0 Min. groove depth: 7.0 Rebate: 13.0 Seal gap: 3.5 - 7.5 Pack size: 125 m x 2		
Doors		
W44266		

F Suitable for Frame Seal **S** Suitable for Sash Seal **O** Suitable for Overlap Seal **C** Suitable for Centre Seal



QL 3034	2Q084	
Groove width: 3.0 - 3.2 Min. groove depth: 8.0 Seal gap: 0.0 - 1.5 Pack size: 400 m x 2		
Doors		
W36276		
Cradle to Cradle Certified® Bronze		

QL 3037	2Q091	
Groove width: 2.7 - 3.0 Min. groove depth: 2.7 Rebate: 13.0 Seal gap: 3.5 - 7.5 Pack size: 125 m x 2		
Doors		
W44266		
Cradle to Cradle Certified® Bronze		

QL 3056	2Q056	
Groove width: 2.7 - 3.0 Min. groove depth: 6.0 Rebate: 9.0 Seal gap: 4.0 - 7.5 Pack size: 300 m x 2		
Doors		
W34275		
Cradle to Cradle Certified® Bronze		

QL 3070	2Q175	
Groove width: 2.7 - 3.0 Min. groove depth: 8.0 Seal gap: 0.0 - 1.5 Pack size: 400 m x 2		
Doors		
W25266		
Cradle to Cradle Certified® Bronze		

QL 3072	2Q182	
Groove width: 2.7 - 3.2 Min. groove depth: 6.5 Rebate: 10.0 Seal gap: 2.7 - 4.3 Pack size: 300 m x 2		
Doors		
W24265		
Cradle to Cradle Certified® Bronze		

QL 3073	2Q189	
Groove width: 4.0 - 5.0 Min. groove depth: 7.5 Rebate: 13.0 Seal gap: 5.0 - 8.0 Pack size: 150 m x 2		
Doors		
W344275		
Cradle to Cradle Certified® Bronze		

QL 3073 FR	2Q193	
Fire retardant		
Groove width: 4.0 - 5.0 Min. groove depth: 7.5 Rebate: 13.0 Seal gap: 5.0 - 8.0 Pack size: 150 m x 2		
Doors		
W344275		

QL 3091	2Q231	
Groove width: 4.0 - 5.0 Min. groove depth: 7.5 Rebate: 15.0 Seal gap: 4.0 - 8.0 Pack size: 150 m x 2 400 m x 1		
Doors		
W44265		
Cradle to Cradle Certified® Bronze		

QL 3091 FR	2Q233	
Fire retardant		
Groove width: 4.0 - 5.0 Min. groove depth: 7.5 Rebate: 15.0 Seal gap: 4.0 - 8.0 Pack size: 150 m x 2 400 m x 10 m x 1		
Doors		
W44265		

QL 3093	2Q238	
Groove width: 2.7 - 3.0 Min. groove depth: 7.0 Rebate: 13.0 Seal gap: 4.0 - 8.0 Pack size: 150 m x 2 400 m x 1		
Doors		
W44266		
Cradle to Cradle Certified® Bronze		

EXCELLENT MEMORY

*Test performed in accordance with classification E 12365 on a selection of Q-LON seals compared with extruded seals

The original formulation of Q-LON enables it to **return to its original shape after being compressed up to 50%** more than other extruded seals, even at extremely low temperatures.

Schlegel
TYMAN group

QL 3094	2Q245	
Groove width: 2.7 - 3.2 Min. groove depth: 6.5 Rebate: 10.0 Seal gap: 3.0 - 6.0 Pack size: 250 m x 2		
Doors		
W32265		
Cradle to Cradle Certified® Bronze		

QL 3095	2Q252	
Groove width: 3.5 - 4.0 Min. groove depth: 6.5 Rebate: 10.0 Seal gap: 3.0 - 6.0 Pack size: 250 m x 2		
Doors		
W32275		
Cradle to Cradle Certified® Bronze		

QL 3096	2Q259	
Groove width: 4.0 - 5.0 Min. groove depth: 7.5 Rebate: 12.0 Seal gap: 3.0 - 6.0 Pack size: 200 m x 2		
Doors		
W35265		
Cradle to Cradle Certified® Bronze		

QL 3097	2Q266	
Groove width: 4.0 - 5.0 Min. groove depth: 7.5 Rebate: 18.0 Seal gap: 3.5 - 6.0 Pack size: 150 m x 2		
Doors		
W35266		
Cradle to Cradle Certified® Bronze		

QL 3098	2Q273	
Groove width: 3.0 - 4.0 Min. groove depth: 7.5 Rebate: 14.0 Seal gap: 3.0 - 6.0 Pack size: 150 m x 2		
Doors		
W33266		
Cradle to Cradle Certified® Bronze		

QL 3099 (QL 3078 RV)	2Q217	
Groove width: 3.0 - 3.3 Min. groove depth: 6.0 Seal gap: 4.0 - 7.5 Pack size: 150 m x 2 300 m x 2		
Doors		
W33266		
Cradle to Cradle Certified® Bronze		

QL 3102	2Q294	
Groove width: 3.7 - 4.2 Min. groove depth: 7.0 Rebate: 11.0 Seal gap: 5.0 - 7.5 Pack size: 200 m x 2		
Doors		
W33266		
Cradle to Cradle Certified® Bronze		

QL 3104	2Q308	
Groove width: 4.0 - 5.0 Min. groove depth: 7.5 Rebate: 12.0 Seal gap: 5.0 - 9.0 Pack size: 200 m x 2		
Doors		
W44275		
Cradle to Cradle Certified® Bronze		

QL 3106	2Q152	
Groove width: 3.5 - 4.0 Min. groove depth: 6.5 Rebate: 12.0 Seal gap: 3.0 - 5.0 Pack size: 250 m x 2		
Doors		
W25276		
Cradle to Cradle Certified® Bronze		

QL 3109	2Q322	
Groove width: 4.0 - 5.0 Min. groove depth: 7.0 Rebate: 18.0 Seal gap: 5.0 - 9.0 Pack size: 100 m x 2		
Doors		
W43276		
Cradle to Cradle Certified® Bronze		

A woman with long, dark hair is seen from the back, looking into an aquarium. A large, dark fish is swimming in the water, and several smaller fish are visible in the background. The scene is lit with a blue-green hue, creating a serene underwater atmosphere.

EFFORTLESS AND PERFECT ADHERENCE

Thanks to the characteristic softness and adaptability of Q-LON, windows require a **low compression force** when closing. Q-LON therefore continues to provide a tight seal even when the window undergoes alterations due to temperature fluctuations or ageing.

Schlegel

TYMAN group



QL 3109 FR	2Q323
Fire retardant	
Groove width: 4.0 - 5.0 Min. groove depth: 7.0 Rebate: 18.0 Seal gap: 5.0 - 9.0 Pack size: 100 m x 2 400 m x 1	
Doors	
W43276	

QL 3110	2Q329
Groove width: 3.5 - 4.0 Min. groove depth: 6.5 Rebate: 12.0 Seal gap: 3.5 - 4.0 Pack size: 150 m x 2	
Doors	
W25266	
Cradle to Cradle Certified® Bronze	

QL 3113	2Q343
Groove width: 3.5 - 4.0 Min. groove depth: 7.0 Rebate: 12.0 Seal gap: 4.0 - 7.5 Pack size: 200 m x 2	
Doors	
W35266	
Cradle to Cradle Certified® Bronze	

QL 3113 FR	2Q345
Fire retardant	
Groove width: 3.5 - 4.0 Min. groove depth: 7.0 Rebate: 12.0 Seal gap: 4.0 - 7.5 Pack size: 200 m x 2	
Doors	
W35266	

QL 3128	2Q420
Groove width: 2.7 - 3.0 Min. groove depth: 7.0 Seal gap: 4.0 - 7.5 Pack size: 300 m x 2	
Doors	
W32265	
Cradle to Cradle Certified® Bronze	

QL 3131 (QL 3070 RV)	2Q427
Groove width: 2.7 - 3.0 Min. groove depth: 8.0 Seal gap: 0.0 - 1.5 Pack size: 400 m x 2	
Doors	
W25266	
Cradle to Cradle Certified® Bronze	

QL 3138	2Q462
Groove width: 2.7 - 3.2 Min. groove depth: 6.0 Rebate: 10.0 Seal gap: 3.0 - 4.5 Pack size: 250 m x 2	
Doors	
W25276	
Cradle to Cradle Certified® Bronze	

QL 3139 (QL 3118 RV)	2Q371
Groove width: 3.0 - 3.3 Min. groove depth: 7.0 Seal gap: 3.0 - 7.5 Pack size: 300 m x 2	
Doors	
W31276	
Cradle to Cradle Certified® Bronze	

QL 3150	2Q500
Groove width: 3.0 Min. groove depth: 6.5 Rebate: 12.0 Seal gap: 3.5 - 6.0 Pack size: 250 m x 2	
Windows	
W33266	

QL 3152	2Q502
Groove width: 3.0 Min. groove depth: 6.5 Rebate: 14/15 Seal gap: 3.5 - 6.0 Pack size: 150 m x 2	
Doors	
W33266	

QL 5626	2Q609	
Groove width: 2.7 - 3.0 Min. groove depth: 6.0 Seal gap: 4.7 - 7.5 Pack size: 300 m x 2		
Doors		
W33256		

QL 5694	2Q616	
Groove width: 2.7 - 3.0 Min. groove depth: 6.0 Seal gap: 6.0 - 11.0 Pack size: 200 m x 2		
Doors		
W43266		
Cradle to Cradle Certified® Bronze		

QL 5878	2Q630	
Groove width: 2.7 - 3.0 Min. groove depth: 6.0 Rebate: 10.0 Seal gap: 3.2 - 4.9 Pack size: 250 m x 2		
Windows		F
W25246		
Cradle to Cradle Certified® Bronze		

QL 7000	2Q749	
Groove width: 2.7 - 3.0 Min. groove depth: 6.0 Rebate: 13.0 Seal gap: 4.0 - 10.8 Pack size: 175 m x 2		
Doors		
W52266		
Cradle to Cradle Certified® Bronze		

QL 7066	2Q763	
Groove width: 2.7 - 3.0 Min. groove depth: 6.0 Rebate: 10.0 Seal gap: 4.8 - 7.7 Pack size: 400 m x 2		
Doors		
W33266		
Cradle to Cradle Certified® Bronze		

QL 9111	2Q8122	
Groove width: 3.0 - 3.3 Min. groove depth: 6.0 Seal gap: 4.8 - 7.9 Pack size: 300 m x 2		
Doors		
W34266		
Cradle to Cradle Certified® Bronze		

QL 9480	2Q812	
Groove width: 2.7 - 3.0 Min. groove depth: 6.0 Seal gap: 3.5 - 7.0 Pack size: 400 m x 1		
Doors		

QL 9608	2Q288	
Groove width: 3.0 Min. groove depth: 6.5 Rebate: 20.0 Seal gap: 4.0 - 7.0 Pack size: 150 m x 2		
Doors		
W33276		

QL 9613	2Q885	
Groove width: 3.0 Min. groove depth: 6.5 Rebate: 18.0 Seal gap: 4.0 - 7.0 Pack size: 150 m x 2		
Doors		
W33276		

QL 9985	2Q959	
Groove width: 2.7 - 3.0 Min. groove depth: 6.0 Rebate: 10.0 Seal gap: 3.0 - 6.5 Pack size: 250 m x 2		
Doors		
W35276		
Cradle to Cradle Certified® Bronze		

QL 70014	2Q752	
Groove width: 4.0 Min. groove depth: 7.0 Rebate: 8.0 Seal gap: 4.1 - 7.0 Pack size: 250 m x 2		
Windows		
W34276		



Q-LON

Brush pile

Extruded

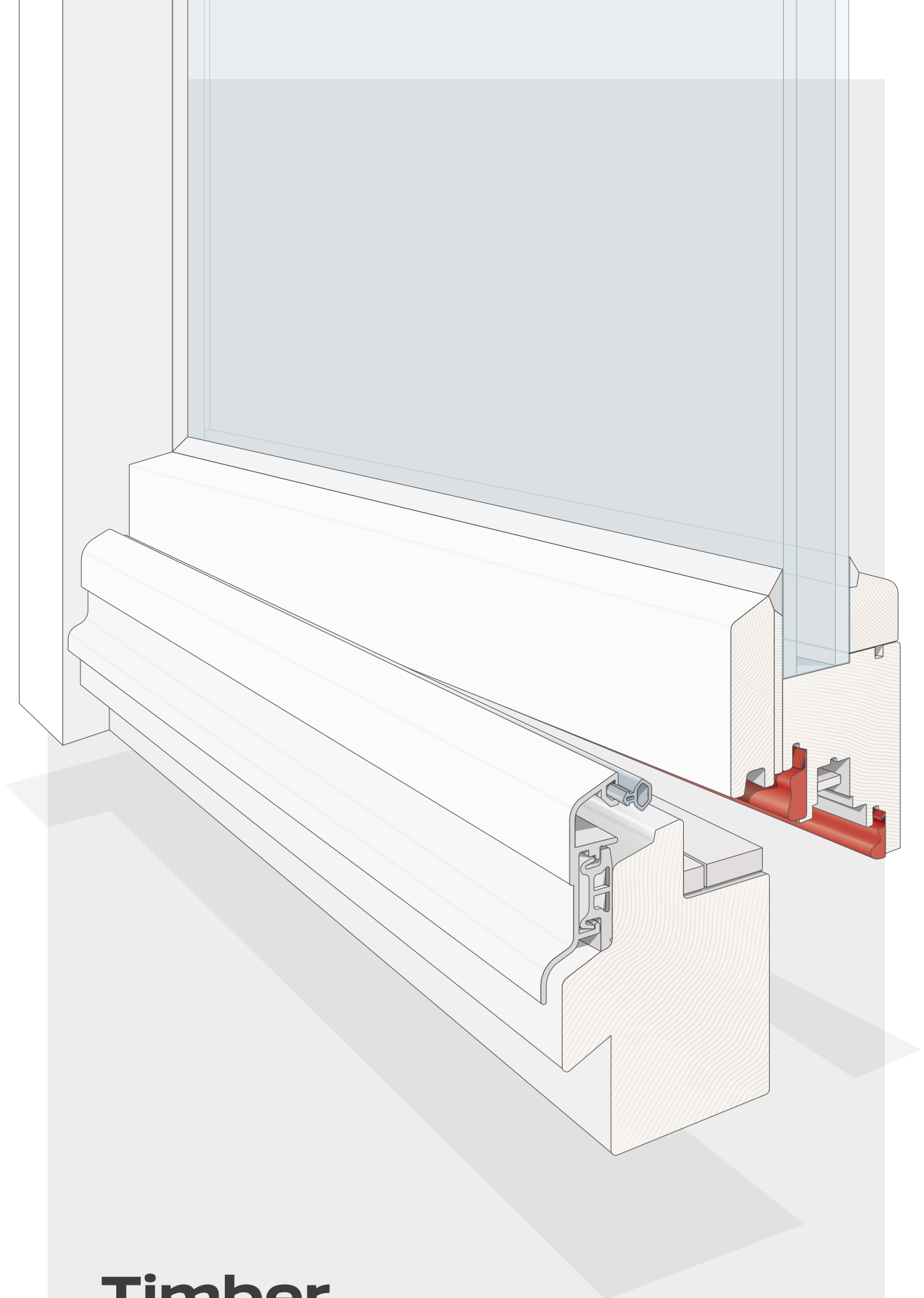

Timber

Timber window applications

QL 3004	2Q014	
Groove width: 2.7 - 3.0 Min. groove depth: 6.0 Rebate: 10.5 Seal gap: 3.0 - 5.0 Pack size: 350 m x 2		
Windows	F	
W26276		
Cradle to Cradle Certified® Bronze		

QL 3013	2Q210	
Groove width: 2.7 - 3.0 Min. groove depth: 6.0 Rebate: 8.0 Seal gap: 2.0 - 3.0 Pack size: 500 m x 2		
Windows	F S	
W15276		
Cradle to Cradle Certified® Bronze		

QL 3005	2Q021	
Groove width: 2.7 - 3.0 Min. groove depth: 6.0 Rebate: 8.0 Seal gap: 3.4 - 5.4 Pack size: 300 m x 2		
Windows	F	
W35266		
Cradle to Cradle Certified® Bronze		

QL 3025 (QL 3004 RV)	2Q014	
Groove width: 2.7 - 3.0 Min. groove depth: 6.0 Rebate: 10.5 Seal gap: 3.0 - 5.0 Pack size: 350 m x 2		
Windows	F	
W25266		
Cradle to Cradle Certified® Bronze		

QL 3006	2Q028	
Groove width: 2.7 - 3.0 Min. groove depth: 6.0 Rebate: 13.0 Seal gap: 5.0 - 13.0 Pack size: 2.1 m x 150		
Windows	F	
W62276		
Cradle to Cradle Certified® Bronze		

QL 3034	2Q084	
Groove width: 2.7 - 3.0 Min. groove depth: 8.0 Rebate: 8.5 Seal gap: 0.0 - 1.5 Pack size: 400 m x 2		
Windows	O S	
W36276		
Cradle to Cradle Certified® Bronze		

QL 3011	2Q042	
Groove width: 2.7 - 3.0 Min. groove depth: 6.0 Rebate: 10.0 Seal gap: 3.5 - 5.5 Pack size: 250 m x 2		
Windows	F	
W35276		
Cradle to Cradle Certified® Bronze		

QL 3037	2Q091	
Groove width: 2.7 - 3.0 Min. groove depth: 6.0 Rebate: 10.0 Seal gap: 3.5 - 5.6 Pack size: 200 m x 2		
Windows	F	
W35266		
Cradle to Cradle Certified® Bronze		

QL 3012	2Q049	
Groove width: 2.7 - 3.0 Min. groove depth: 6.0 Rebate: 11.0 Seal gap: 4.0 - 6.5 Pack size: 200 m x 2		
Windows	F	
W45276		
Cradle to Cradle Certified® Bronze		

QL 3053	2Q105	
Groove width: 4.0 - 5.0 Min. groove depth: 7.5 Rebate: 12.0 Seal gap: 4.5 - 6.0 Pack size: 200 m x 2		
Windows	C S	
W35266		
Cradle to Cradle Certified® Bronze		

F Suitable for Frame Seal **S** Suitable for Sash Seal **O** Suitable for Overlap Seal **C** Suitable for Centre Seal



QL 3054	2Q112
Groove width: 2.8 - 3.2 Min. groove depth: 5.5 Rebate: 10.0 Seal gap: 4.0 - 6.0 Pack size: 250 m x 2	
Windows	O
W35276	
Cradle to Cradle Certified® Bronze	

QL 3063	2Q147
Groove width: 4.0 - 5.0 Min. groove depth: 7.5 Rebate: 12.0 Seal gap: 5.5 - 7.5 Pack size: 200 m x 2	
Windows	C S
W36266	
Cradle to Cradle Certified® Bronze	

QL 3063 FR	2Q149
Fire retardant	
Groove width: 4.0 - 5.0 Min. groove depth: 7.5 Rebate: 12.0 Seal gap: 5.5 - 7.5 Pack size: 200 m x 2	
Windows	C S
W36266	

QL 3067	2Q161
Groove width: 4.0 - 5.0 Min. groove depth: 7.5 Rebate: 12.0 Seal gap: 4.0 - 6.0 Pack size: 200 m x 2	
Windows	C S
W25266	
Cradle to Cradle Certified® Bronze	

QL 3068	2Q168
Groove width: 3.4 - 4.2 Min. groove depth: 6.5 Rebate: 11.0 Seal gap: 4.5 - 6.5 Pack size: 200 m x 2	
Windows	C S
W35275	
Cradle to Cradle Certified® Bronze	

QL 3072	2Q182
Groove width: 2.7 - 3.2 Min. groove depth: 6.5 Rebate: 10.0 Seal gap: 2.7 - 4.3 Pack size: 300 m x 2	
Windows	C S
W24265	
Cradle to Cradle Certified® Bronze	

QL 3074	2Q196
Groove width: 2.7 - 3.2 Min. groove depth: 6.5 Rebate: 8.5 Seal gap: 3.5 - 5.5 Pack size: 300 m x 2	
Windows	F
W22276	
Cradle to Cradle Certified® Bronze	

QL 3076	2Q203
Groove width: 3.0 - 3.5 Min. groove depth: 6.0 Rebate: 10.0 Seal gap: 3.0 - 6.0 Pack size: 250 m x 2	
Windows	F
W34266	
Cradle to Cradle Certified® Bronze	

QL 3077 (QL 3013 RV)	2Q210
Groove width: 2.7 - 3.0 Min. groove depth: 6.0 Rebate: 8.0 Seal gap: 2.0 - 3.0 Pack size: 500 m x 2	
Windows	F S
W36266	
Cradle to Cradle Certified® Bronze	

QL 3078	2Q217
Groove width: 3.0 - 3.3 Min. groove depth: 6.0 Rebate: 10.5 Seal gap: 4.0 - 7.5 Pack size: 250 m x 2 300 m x 2	
Windows	F
W34266	
Cradle to Cradle Certified® Bronze	

QL 3079	2Q224	
Groove width: 3.2 - 4.0 Min. groove depth: 6.5 Rebate: 10.0 Seal gap: 2.7 - 4.3 Pack size: 300 m x 2		
Windows	F S	
W24266		
Cradle to Cradle Certified® Bronze		

QL 3128	2Q420	
Groove width: 2.7 - 3.0 Min. groove depth: 7.0 Rebate: 9.0 Seal gap: 4.0 - 7.5 Pack size: 300 m x 2		
Windows	F	
W32265		
Cradle to Cradle Certified® Bronze		

QL 3082	2Q308	
Groove width: 2.7 - 3.2 Min. groove depth: 5.0 Rebate: 8.0 Seal gap: 3.0 - 5.0 Pack size: 250 m x 2		
Windows	F	
W35275		
Cradle to Cradle Certified® Bronze		

QL 3131 (QL 3070 RV)	2Q427	
Groove width: 2.7 - 3.0 Min. groove depth: 8.0 Rebate: 8.0 Seal gap: 0.0 - 1.5 Pack size: 400 m x 2		
Windows	O	
W25266		
Cradle to Cradle Certified® Bronze		

QL 3101	2Q021	
Groove width: 2.7 - 3.2 Min. groove depth: 7.0 Rebate: 13.0 Seal gap: 3.5 - 6.0 Pack size: 200 m x 2		
Windows	C	
W35276		
Cradle to Cradle Certified® Bronze		

QL 3140	2Q476	
Groove width: 4.0 - 5.0 Min. groove depth: 7.5 Rebate: 15.0 Seal gap: 4.0 - 6.5 Pack size: 200 m x 2		
Windows	C	
W35266		
Cradle to Cradle Certified® Bronze		

QL 3111	2Q336	
Groove width: 3.5 - 4.0 Min. groove depth: 7.0 Rebate: 12.0 Seal gap: 3.5 - 4.0 Pack size: 200 m x 2		
Windows	C S	
W35256		
Cradle to Cradle Certified® Bronze		

QL 3141	2Q483	
Groove width: 2.7 - 3.2 Min. groove depth: 5.5 Rebate: 12.0 Seal gap: 4.0 - 6.5 Pack size: 300 m x 2		
Windows	C O	
W35255		
Cradle to Cradle Certified® Bronze		

QL 3118	2Q371	
Groove width: 3.0 - 3.3 Min. groove depth: 7.0 Rebate: 9.0 Seal gap: 3.0 - 7.5 Pack size: 300 m x 2		
Windows	F	
W31276		
Cradle to Cradle Certified® Bronze		

QL 3143	2Q490	
Groove width: 2.7 - 3.0 Min. groove depth: 6.0 Rebate: 10.5 Seal gap: 3.0 - 5.0 Pack size: 350 m x 2		
Windows		
W26275		
Cradle to Cradle Certified® Bronze		

C Suitable for Centre Seal
O Suitable for Overlap Seal
S Suitable for Sash Seal
F Suitable for Frame Seal



QL 3147 (QL 3076 RV)	2Q203
Groove width: 3.0 - 3.5 Min. groove depth: 6.0 Rebate: 10.0 Seal gap: 3.0 - 6.0 Pack size: 250 m x 2	
Windows	
W34266	
Cradle to Cradle Certified® Bronze	

C Suitable for Centre Seal

O Suitable for Overlap Seal

S Suitable for Sash Seal

F Suitable for Frame Seal

*Test performed to UNI EN ISO 10140-2 on a selection of Q-LON seals compared with extruded seals.

EXCELLENT SOUND INSULATION

Exceptional acoustic **insulation performance** thanks to high compression ability.
Up to 4 dB* noise reduction compared with extruded seals.

Schlegel

TYMAN group



Q-LON

Brush pile

Extruded

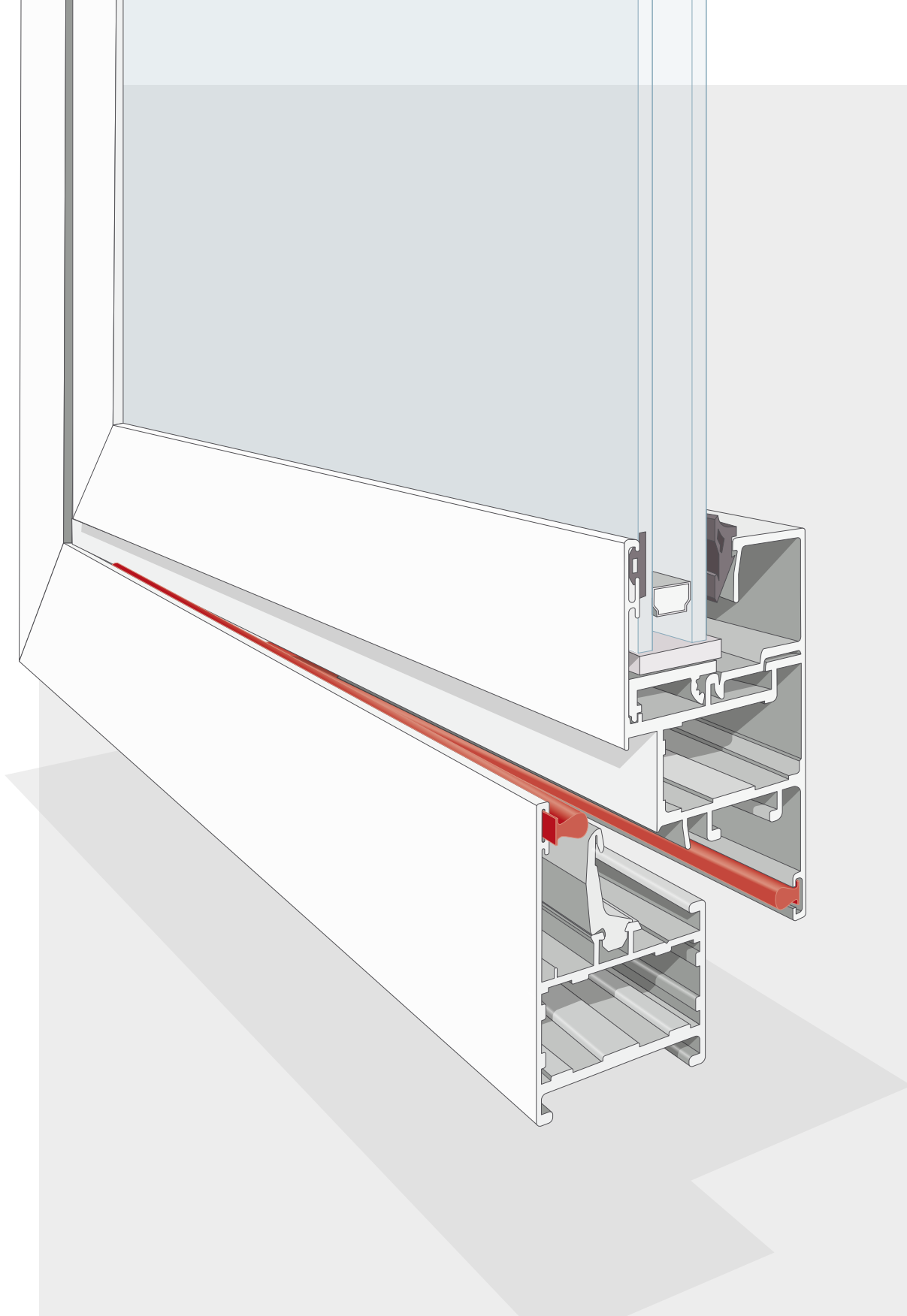

Aluminium

Applications on aluminium doors and windows

QL 4636	2Q512
Throat width: 3.2 Min. groove depth: 2.3 Seal gap: 1.0 - 2.5 Pack size: 300 m x 2	
Windows / other T-slot type A (5.3)	
Cradle to Cradle Certified® Bronze	

QL 4870	2Q517
Throat width: 3.2 Min. groove depth: 2.3 Seal gap: 2.5 - 4.0 Pack size: 250 m x 2	
Windows / doors / other T-slot type A (5.3)	
W23266	
Cradle to Cradle Certified® Bronze	

QL 6970	2Q693
Throat width: 4.6 Min. groove depth: 2.3 Seal gap: 2.5 - 4.0 Pack size: 250 m x 2	
Windows / doors / other T-slot type C (7.5)	
Cradle to Cradle Certified® Bronze	

QL 46105	2Q529
Throat width: 3 - 3.2 Groove width: 5 - 5.6 Seal gap: 5 - 5.6 Pack size: 250 m x 2	
Overlap seal	
W36276	
Cradle to Cradle Certified® Bronze	

QL 46800	2Q577
Throat width: 2.6 - 3.2 Groove width: 5 - 5.6 Seal gap: 3 - 3.5 Pack size: 250 m x 2	
Overlap seal	
W25266	
Cradle to Cradle Certified® Bronze	

QL 48100	2Q516
Throat width: 3.2 Min. groove depth: 2.3 Seal gap: 5.5 - 7.0 Pack size: 250 m x 2	
Windows / doors / other T-slot type A (5.3)	
Cradle to Cradle Certified® Bronze	

QL 48400	2Q518
Throat width: 3.2 Groove depth: 2.3 Seal gap: 1.1 - 2.4 Pack size: 200 m x 2 700 m x 2 900 m x 2	
Windows / other T-slot type A (5.3)	
W16266	
Cradle to Cradle Certified® Bronze	

QL 48510	2Q532
Throat width: 3.2 Groove depth: 2.3 Seal gap: 1.1 - 2.4 Pack size: 200 m x 2 500 m x 2 900 m x 2	
Windows / other T-slot type A (5.3)	
W15256	
Cradle to Cradle Certified® Bronze	

QL 48650	2Q539
Throat width: 3.2 Groove depth: 2.3 Seal gap: 1.8 - 3.4 Pack size: 200 m x 2 500 m x 2 800 m x 2	
Windows / other T-slot type A (5.3)	
W25256	
Cradle to Cradle Certified® Bronze	

QL 48650 FR	2Q536
Fire retardant	
Throat width: 3.2 Groove depth: 2.3 Seal gap: 1.8 - 3.4 Pack size: 500 m x 2	
Windows / other T-slot type A (5.3)	
W25256	



QL 48700	2Q546	
Throat width: 3.2 Groove depth: 2.3 Seal gap: 2.5 - 6.0 Pack size: 250 m x 2		
Windows / doors / other		
T-slot type A (5.3)		
W15256		
Cradle to Cradle Certified® Bronze		

QL 57700	2Q623	
Throat width: 3.8 Groove depth: 2.3 Seal gap: 2.3 - 4.0 Pack size: 200 m x 2		
Windows / other		
T-slot type B (6.3)		
W25266		
Cradle to Cradle Certified® Bronze		

QL 48750	2Q553	
Throat width: 3.2 Groove depth: 2.3 Seal gap: 2.7 - 4.6 Pack size: 200 m x 2 600 m x 2		
Windows / other		
T-slot type A (5.3)		
W25266		
Cradle to Cradle Certified® Bronze		

QL 69100	2Q694	
Throat width: 4.6 Min. groove depth: 2.3 Seal gap: 5.5 - 7.0 Pack size: 250 m x 2		
Windows / doors / other		
T-slot type C (7.5)		
W33276		
Cradle to Cradle Certified® Bronze		

QL 48750 FR	2Q554	
Fire retardant		
Throat width: 3.2 Groove depth: 2.3 Seal gap: 2.7 - 4.6 Pack size: 600 m x 2		
Windows / other		
T-slot type A (5.3)		
W25266		

QL 69400	2Q697	
Throat width: 4.6 Groove depth: 2.3 Seal gap: 0.5 - 1.5 Pack size: 700 m x 2 900 m x 2		
Windows / other		
T-slot type C (7.5)		
W15256		
Cradle to Cradle Certified® Bronze		

QL 48800	2Q560	
Throat width: 3.2 Groove depth: 2.3 Seal gap: 2.5 - 7.0 Pack size: 250 m x 2		
Windows / doors / other		
T-slot type A (5.3)		
W34276		
Cradle to Cradle Certified® Bronze		

QL 69510	2Q707	
Throat width: 4.6 Groove depth: 2.3 Seal gap: 1.1 - 2.4 Pack size: 700 m x 2		
Windows / other		
T-slot type C (7.5)		
W15246		
Cradle to Cradle Certified® Bronze		

QL 48950	2Q567	
Throat width: 3.2 Groove depth: 2.3 Seal gap: 4.0 - 6.5 Pack size: 200 m x 2 500 m x 2		
Windows / doors / other		
T-slot type A (5.3)		
W34266		
Cradle to Cradle Certified® Bronze		

QL 69650	2Q714	
Throat width: 4.6 Groove depth: 2.3 Seal gap: 1.8 - 3.4 Pack size: 200 m x 2 400 m x 2 600 m x 2		
Windows / other		
T-slot type C (7.5)		
W15266		
Cradle to Cradle Certified® Bronze		

QL 69700	2Q990
Throat width: 4.6 Min. groove depth: 2.3 Seal gap: 2.5 - 6.0 Pack size: 250 m x 2	
Windows / doors / other T-slot type C (7.5)	
W33266	
Cradle to Cradle Certified® Bronze	

QL 70012	2Q943
Throat width: 4.6 Groove depth: 7.5 Seal gap: 4.5 - 8.5 Pack size: 250 m x 2	
Windows / doors / other T-slot type C (7.5)	
W32266	

QL 69750	2Q721
Throat width: 4.6 Groove depth: 2.3 Seal gap: 2.7 - 4.6 Pack size: 200 m x 2 500 m x 2	
Windows / other T-slot type C (7.5)	
W24266	
Cradle to Cradle Certified® Bronze	

QL 70013	2Q936
Throat width: 3.2 Groove depth: 5.3 Seal gap: 4.5 - 8.5 Pack size: 250 m x 2	
Windows / doors / other T-slot type C (7.5)	
W32266	

QL 69800	2Q728
Throat width: 4.6 Groove depth: 2.3 Seal gap: 2.5 - 7.0 Pack size: 250 m x 2	
Windows / doors / other T-slot type C (7.5)	
W34266	
Cradle to Cradle Certified® Bronze	

QL 69950	2Q742
Throat width: 4.6 Groove depth: 2.3 Seal gap: 4.0 - 6.5 Pack size: 200 m x 2 350 m x 2	
Windows / doors / other T-slot type C (7.5)	
W34266	
Cradle to Cradle Certified® Bronze	

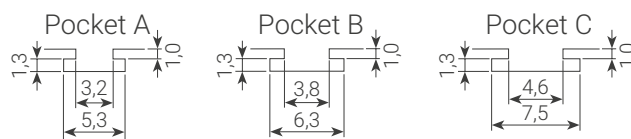
T-Slot dimensions



Q-LON

Brush pile

Extruded

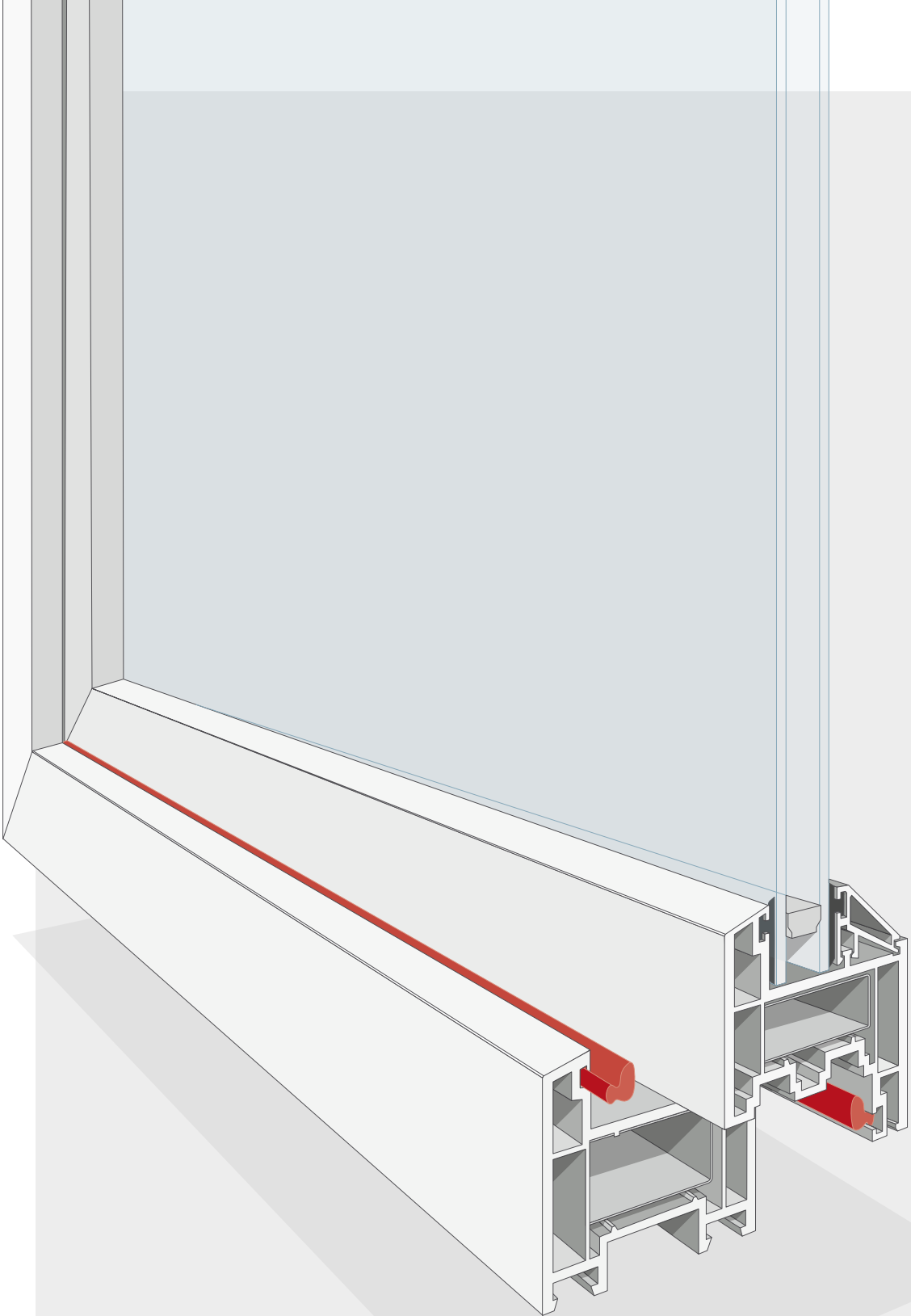

PVCu

Aluminium doors and window applications

QL 4465	2Q505	
Throat width: 4.2 Min. groove depth: 5.7 Seal gap: 3.0 - 4.8 Pack size: 250 m x 2		
Doors / windows		
W25266		
Cradle to Cradle Certified® Bronze		

QL 7032	2Q756	
Throat width: 3.0 Min. groove depth: 4.5 Seal gap: 1.5 - 5.1 Pack size: 200 m x 2		
Doors / windows		
W34266		
Cradle to Cradle Certified® Bronze		

QL 4636	2Q512	
Throat width: 3.2 Min. groove depth: 2.3 Seal gap: 1.0 - 2.5 Pack size: 300 m x 2		
Windows		
T-slot type A (5.3 mm)		
Cradle to Cradle Certified® Bronze		

QL 7307	2Q770	
Throat width: 3.2 Min. groove depth: 4.8 Seal gap: 2.8 - 4.4 Pack size: 250 m x 2		
Windows		
W35276		
Cradle to Cradle Certified® Bronze		

QL 5570	2Q602	
Throat width: 3.3 Min. groove depth: 5.5 Seal gap: 3.0 - 4.8 Pack size: 250 m x 2		
Windows		
W24266		
Cradle to Cradle Certified® Bronze		

QL 9005	2Q785	
Throat width: 2.4 Min. groove depth: 5.2 Seal gap: 2.5 - 4.1 Pack size: 300 m x 2		
Windows		
W24266		
Cradle to Cradle Certified® Bronze		

QL 6571	2Q680	
Throat width: 3.0 Min. groove depth: 4.9 Seal gap: 3.0 - 5.0 Pack size: 250 m x 2		
Windows		
W35266		
Cradle to Cradle Certified® Bronze		

QL 9100	2Q791	
Throat width: 2.4 Min. groove depth: 5.3 Seal gap: 2.7 - 4.4 Pack size: 250 m x 2		
Windows		
W35276		
Cradle to Cradle Certified® Bronze		

QL 6991	2Q735	
Throat width: 3.9 Min. groove depth: 5.3 Seal gap: 2.0 - 3.2 Pack size: 300 m x 2		
Windows		
W25266		
Cradle to Cradle Certified® Bronze		

QL 9112	2Q819	
Throat width: 3.2 Min. groove depth: 4.8 Seal gap: 3.0 - 4.9 Pack size: 300 m x 2		
Windows		
W35276		
Cradle to Cradle Certified® Bronze		



QL 9154	2Q834	
Throat width: 3.2 Min. groove depth: 4.7 Seal gap: 2.8 - 4.5 Pack size: 300 m x 2		
Windows		
W35266		
Cradle to Cradle Certified® Bronze		

QL 9646	2Q878	
Throat width: 3.6 Min. groove depth: 5.1 Seal gap: 3.5 - 5.5 Pack size: 250 m x 2		
Windows		
W35276		
Cradle to Cradle Certified® Bronze		

QL 9257	2Q842	
Throat width: 3.2 Min. groove depth: 4.4 Seal gap: 4.5 - 7.1 Pack size: 300 m x 2		
Doors / windows		
W33276		
Cradle to Cradle Certified® Bronze		

QL 9688	2Q882	
Throat width: 2.8 Min. groove depth: 3.9 Seal gap: 3.0 - 7.0 Pack size: 400 m x 2		
Doors / windows		
W33276		
Cradle to Cradle Certified® Bronze		

QL 9489	2Q855	
Throat width: 3.4 Min. groove depth: 4.0 Seal gap: 2.5 - 4.0 Pack size: 250 m x 2		
Doors / windows		
W26276		
Cradle to Cradle Certified® Bronze		

QL 9898	2Q911	
Throat width: 3.2 Min. groove depth: 4.9 Seal gap: 3.0 - 5.5 Pack size: 300 m x 2		
Windows		
W35276		
Cradle to Cradle Certified® Bronze		

QL 9536	2Q861	
Throat width: 3.9 Min. groove depth: 6.3 Seal gap: 4.0 - 8.0 Pack size: 250 m x 2		
Doors		
W43276		

QL 9926	2Q931	
Throat width: 3.2 - 3.4 Min. groove depth: 5.0 Seal gap: 3.0 - 7.5 Pack size: 300 m x 2		
Doors / windows		
W33276		
Cradle to Cradle Certified® Bronze		

QL 9596	2Q873	
Throat width: 3.4 Min. groove depth: 5.2 Seal gap: 2.5 - 4.0 Pack size: 300 m x 2		
Windows		
W26276		

QL 9928	2Q940	
Throat width: 3.2 - 3.4 Min. groove depth: 3.9 Seal gap: 3.0 - 7.5 Pack size: 300 m x 2		
Doors / windows		
W34276		
Cradle to Cradle Certified® Bronze		

Q-LON FOR SLIDING DOORS



Compared with common brush seals, Q-LON offers highly superior air/water tightness, noise insulation performance and styling. Tested for friction damage on sliding doors to 40,000 cycles.

Schlegel
TYMAN group



Accessories

Q-LON cover cap

For French windows

Special colour-coordinated caps made from resistant HDPE for various groove and rebate dimensions.

For Q-LON seal	Part No.	SAP Part No.	Groove	Rebate
QL 3053	MIS-9124	2Q982	4.0	12.0
	MIS-9125	2Q985	5.0	
	MIS-9184	2Q986	4.0	18.0 - 20.0
	MIS-9185	2Q983	5.0	
QL 3054	MIS-9103	2Q980	3.0	10.0

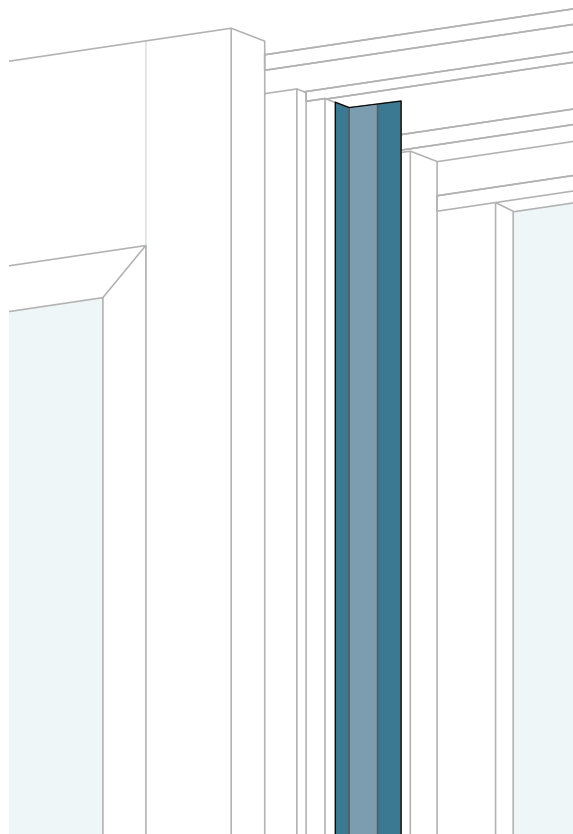
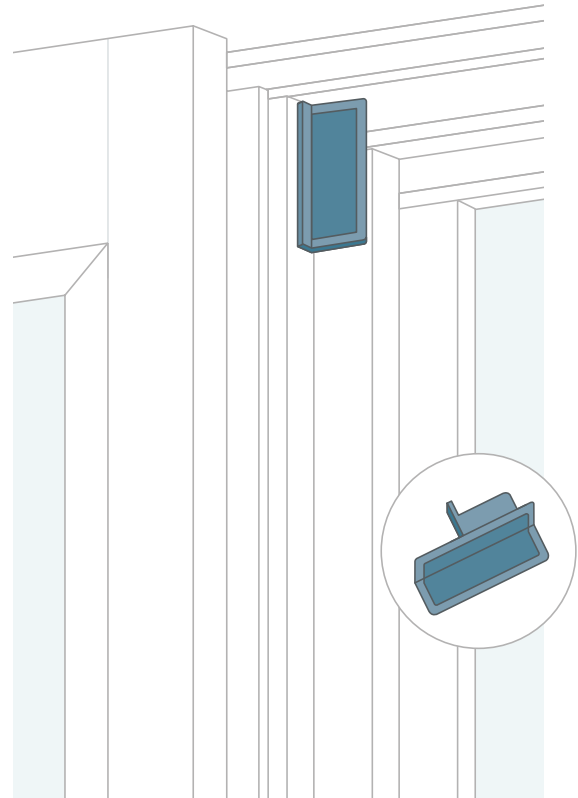

Lozaron cover profiles

For French windows

Colour coordinated profile made from TPE, compatible with acrylic paint.

For Q-LON seal	Part No.	SAP Part No.	Groove	Rebate
QL 3053	DX 1362	26070	4.0 - 5.0	12 + 18 - 20

Instructions

Q-LON profile installation

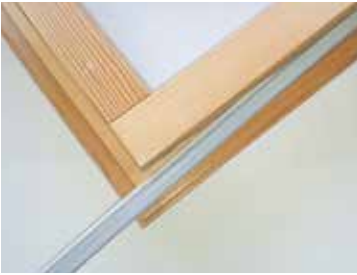

Step 1

The Q-LON profile is pressed into the groove at the centre of the sash.



Step 2

The Q-LON pliers are placed in the rebate corner with the stop and a 90° mitre is cut out.

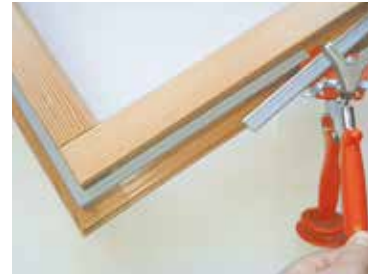

Step 3

The final cut: by positioning the pliers against the profile as shown, the final cut is made based on the precise length.

Corner jointing with silicone mastic



Timber

Bonding of interrupted butt joint.



Timber

Bonding of mitre-cut joint.



PVCu and aluminium

Enhancement of continuous seal.

Colourless Wacker Elastosil A07 RTV-1 silicone rubber / adhesive
(or equivalent)

Tools



QL MIS-9001-99 MITRE CUTTERS 90°

With an insertion roller for 90° and end cuts for assembly in the frame.

Part no.:
2T00000001



QL INSERTION ROLLER

Manual profile roller.

Part no.:
2T005000



Q-LON OVERLAP INSERTION ROLLER

Manual profile roller.

Part no.:
2T030000

Brush pile seals and sealing profiles

For timber, aluminium and PVC applications



Q-LON

Brush pile

Extruded

Index

Materials and colours	51
Selector	57
Certifications	58
Quality control	61
Technical specifications	
Brush pile seals	62
Poly-Bond (PB): woven brush pile seals	63
Fin-Seal (FS): woven brush pile seals	64
Dust-Plug (DP): woven brush pile seals	65
Shutter-Pile (SP): woven brush pile seals	66
Power-Pile (PW): extruded brush pile seals	67
Fin-Pile (FP): extruded brush pile seal	68
G3: extruded brush pile seals	69
G3-QF (Quadrafin): extruded brush pile seals	70
Bi-Fin (BF): extruded brush pile seals	71
Angle-Pile (AP): extruded brush pile seals	72
Skirting-Fringe (SF): extruded brush pile seals	73
Flex-Brush (FB): coilable brush pile seals	74
Kerf-Pile (KP): extruded brush pile seals	75
Combination brush pile seals	76
For universal surface fitting	77
For kerf-slot fitting	77
Carriers for brush pile seals	78

Materials and colours

Seals made from virgin polypropylene (PP) yarn.

- Available in many different widths and heights
- Different densities depending on seal type, width and mounting distance
- Heat setting for recovery after compression
- With optional adhesive backing based on hot-melt (HM) glue technology

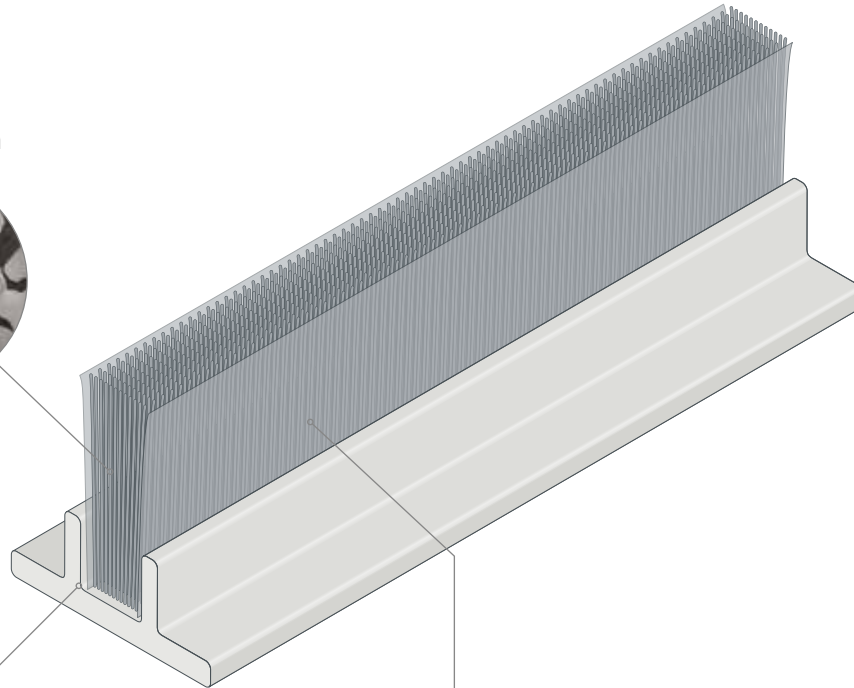

Trilobal PP-yarn



Monofilament

Untreated for increased stiffness
Available in the following colours:

Standard Colours

-  GREY / RAL 7045 / Code 277
-  BLACK / RAL 9005 / Code 288
-  NEUTRAL / RAL / Code 000



Multifilament

Standard soft multifilament yarn
Available in the following colours:

Standard Colours

-  BEIGE / RAL 1011 / Code 241
-  DARK GOLD / RAL 1032 / Code 292
-  GREY / RAL 7045 / Code 277
-  PALE BROWN / RAL 8025 / Code 291
-  BROWN / RAL 8028 / Code 264
-  WHITE / RAL 9003 / Code 287
-  BLACK / RAL 9005 / Code 288

Extra Colours

-  IVORY / RAL 1015 / Code 266
-  IRON GREY / RAL 7011 / Code 240
-  DARK BEIGE / RAL 8008 / Code 244
-  SEPIA BROWN / RAL 8014 / Code 281

EASY SLIDING

Excellent resistance to abrasion and static build-up and low friction for improved sliding performance.

Schlegel
TYMAN group



VERY LOW AIR PERMEABILITY

The central and lateral fins offer
better air tightness.

Schlegel
TYMAN group

Selector

Brush pile seals

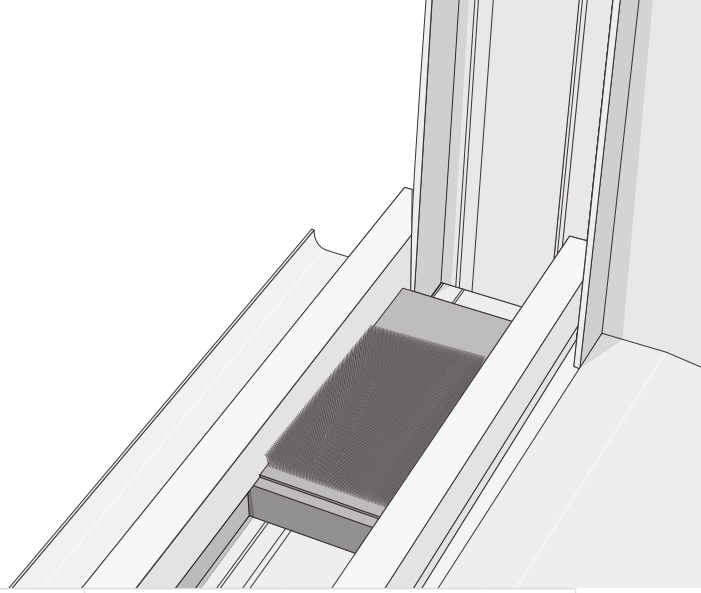

	Product application area				Product dimensions				Brush pile and backing characteristics and options							
	Sliding window	Sliding door	Window covering	Furniture	Carrier width		Brush height		Angle	Filament type	Density	Adhesive (Hot Melt)	Fin position	Fin height	Optimised for auto insertion	Page
					Min	Max	Min	Max								
WOVEN CARRIER																
POLY-BOND	x	x	x	x	4.8 / 6.7 / 6.9		3.0	15.0	90°	Multi	4P	Optional	-	-	-	20
FIN-SEAL	x	x	x	-	4.8 / 6.7 / 6.9		3.0	15.0	90°	Multi	4P	Optional	Centre	0 / 1	-	21
EXTRUDED CARRIER																
POWER-PILE	x	x	x	x	4.8 / 6.7 / 6.9		5.0	20.0	90°	Multi	4P	-	-	-	x	22
FIN-PILE	x	x	x	-	4.8 / 6.7 / 6.9		5.0	20.0	90°	Multi	4P	-	Centre	0	x	23
G3	x	x	x	-	4.8 / 6.7 / 6.9		4.0	20.0	90°	Multi	4P	-	Centre	0 / 1	x	24
G3-QF QUADRAFIN	x	x	x	-	4.8 / 6.7 / 6.9		6.0	12.0	90°	Multi	4P	-	Centr./ Later.		x	25
BI-FIN	x	x	x	-	4.8 / 6.7 / 6.9		6.0	20.0	90°	Multi	4P	-	Lateral	0	x	26
SPECIAL PRODUCTS																
ANGLE-PILE	-	-	x	-	4.8 / 6.9		9.0	22.0	45° 60°	Mono	24	-	-	-	x	27
DUST-PLUG	x	x	-	x	10.0	60.0	3.0	22.0	90°	Mono Multi	8P 76P	Optional	Optional	Optional	-	28
SHUTTER-PILE	-	-	x	-	4.8 / 6.7 / 6.9		3.0	15.0	90°	Mono Multi	2P / 3P	Optional	-	-	-	29
SKIRTING FRINGE	x	x	x	-	2.7 / 2.9 / 3.1 / 3.3		5.0	30.0	90°	Mono	24	-	-	-	x	30
	x	x	x	-	2.7 / 2.9 / 3.1 / 3.3		5.0	30.0	90°	Multi	4P	-	-	-	x	30
FLEX-BRUSH	x	x	-	-	3.5	5	10.0	50.0	90°	Mono	HD15 SD15	-	-	-	-	31
KERF-PILE	x	x	-	-	Groove width: 3		5.0	25.0	90°	Multi	5P	-	-	-	x	32

For more details and options see the rest of this catalogue, or consult www.schlegelgiesse.com.

Cradle to Cradle certifications

The construction industry is just one of many sectors that are adapting to meet the need for **more sustainable production processes** and more efficient use of resources.

The current transition towards a circular economy is driving **Schlegel** towards the use of materials and products free from chemicals that harm

people and the environment, without however reducing our high quality standards.

Sustainability certifications also hold important value in the market, especially since some countries have imposed mandatory environmental certification for specific products.



In 2020 Schlegel joined the certification programme led by the Cradle to Cradle Products Innovation Institute. This innovative initiative promotes sustainability by driving the transformation towards the design and production of products with a positive impact.

The Cradle to Cradle Certified® Products Programme is a multi-attribute, continuous improvement methodology that evaluates products across five categories of human and environmental health.

It evaluates products across five categories of human and environmental health. Each product is assigned a level for each category.

The standard encourages continuous improvement over time by awarding certification based on ascending levels of achievement.

Cradle to Cradle Certified® is recognised as a preferred product certification by many leading brands, organisations and sustainability standards. For Tyman International this is only the first step towards more ambitious goals.

Material health

Products are designed and developed through a process of inventorying, assessing and optimising chemical materials.

Circular economy

No more waste: products remain in a perpetual cycle of use and reuse.

Renewable energy & Carbon management

Products are manufactured using renewable energy.

Water stewardship

Since water is a valuable resource, watersheds are protected, leaving clean water available to people and all other organisms.

Social fairness

Business operations have to take into account all people and natural systems affected by a product manufacturing cycle.



Find out more about the **Cradle to Cradle®** certification system

DURABLE

UV stable and chemically inert for prolonged life.

Schlegel
TYMAN group

RESISTANCE

PP yarn treated with silicone to resist water, mould and mildew.

Schlegel
TYMAN group



Quality control

The standard tests conducted by Schlegel in its Aycliffe laboratories are:

- QUV - accelerated weathering test (3000 hours)
- Air permeability - the amount of air entering through the seal at various pressures (in accordance with EN 1026)
- Recovery after long-term compression - to analyse permanent deflection after long-term compression (according to EN 12365:2003 IFT Laboratory certificate)
- Wear resistance - simulation of sliding/scrubbing for 100,000 cycles

Our products are manufactured to meet the requirements of our many international customers in different industries. We use a Quality Management System registered and certified to the ISO 9001:2015 standard and an Environmental Management System to ISO 14001:2015.

We invite you to browse through our range in this brochure or on our website, where you can use our product filter to find the right brush pile seal for you. Please contact us for any further information or specific requirements.

Manufactured to ISO 45001:2018
Health & Safety Standard

Manufactured to ISO 9001:2015
Quality Control System

Manufactured to ISO 14001:2015
Environmental Control System





Q-LON

Brush pile

Extruded

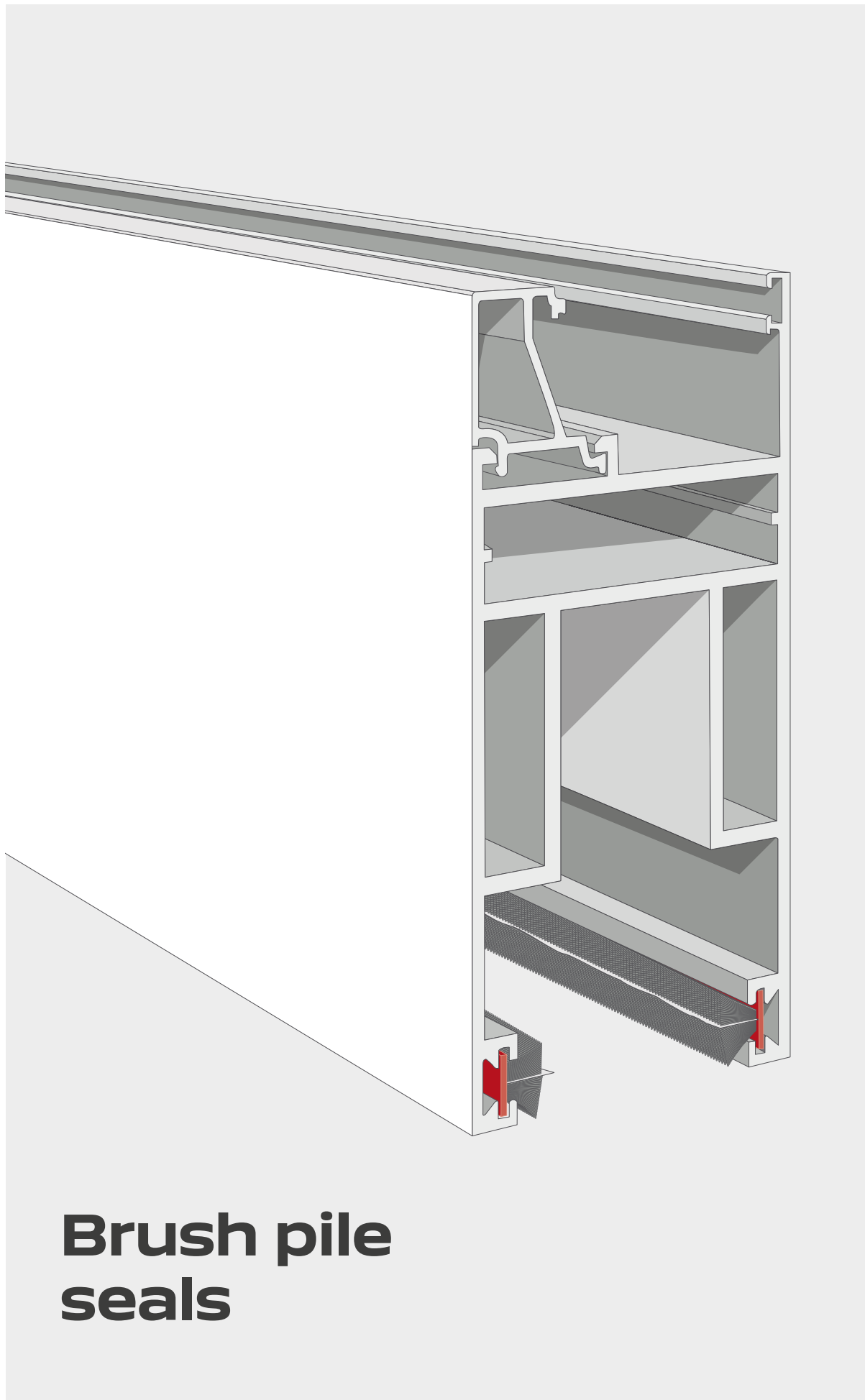

Brush pile seals

Poly-Bond (PB)

woven brush pile seals



Soft silicone treated multifilament pile yarn on a woven reinforced translucent backing for all common economy sealing applications.

Optional adhesive backing.

Recommended compression:

- Brush pile height from 3.0 to 5.0 mm: 5% to 10%
- Brush pile height from 5.5 to 6.5 mm: 10% to 20%
- Brush pile height from 7.0 mm and above: 15% to 25%



Dimensions				
	4.8	6.7	6.9	
H	5.3	7.5	7.7	
I	3.2	3.2	3.2	
J	1.3	1.3	1.3	
Minimum clearance recommended: +0.5 mm of backing width chosen				

Standard solutions				
A Backing width*	B Backing thickness	C Pile carrier width	D Brush height	E Brush density (P)
4.8 +0.10/-0.15 mm 6.7 +0.10/-0.20 mm 6.9 +0.10/-0.20 mm	0.8 ± 0.15 mm	2.4 ± 0.3 mm	3.0 ≤ D ≤ 6.5 mm (+0.25/-0.15 mm) with 0.50 mm intervals 6.5 < D ≤ 10.0 mm (+4%/-2.5%) with 0.50 mm intervals 10.0 < D ≤ 15.0 mm (+4%/-2.5%) with 1.0 mm intervals	4P

*With optional hot-melt (HM) adhesive • Note: total height will increase up to 0.5 mm if hot-melt requested

Colours						
Multifilament pile yarn colours						
Beige RAL 1011	Dark Gold RAL 1032	Grey RAL 7045	Pale Brown RAL 8025	Brown RAL 8028	White RAL 9003	Black RAL 9005

Fin-seal (FS)

woven brush pile seals



Soft silicone treated multifilament pile yarn on a woven reinforced translucent backing. With welded clear central fin for improved weather sealing of sliding windows and doors. Optional adhesive backing. Optional adhesive backing.

Recommended compression:

- Brush pile height from 3.0 to 5.0 mm: 5% to 10%.
Fin should be plus 1 mm
- Brush pile height from 5.5 to 6.5 mm: 10% to 20%.
Fin level or plus 1 mm
- Brush pile height from 7.0 to 11 mm: 15% to 25%.
Fin level or plus 1 mm
- Brush pile height from 12.0 mm and above: 15% to 25%.
Level fin only



Dimensions			
	4.8	6.7	6.9
H	5.3	7.5	7.7
I	3.2	3.2	3.2
J	1.3	1.3	1.3
Minimum clearance recommended: +0.5 mm of backing width chosen			

Standard solutions					
A Backing width*	B Backing thickness	C Pile carrier width	D Brush height	E Fin height**	F Brush density (P)
4.8 +0.10/-0.15 mm	0.8 ± 0.15 mm	2.4 ± 0.3 mm	3 ≤ D ≤ 5 mm (+0.25/-0.15 mm) with 0.50 mm intervals	D+1 mm (+0.25/-0.15 mm with 0.50 mm intervals)	4P
6.7 +0.10/-0.20 mm			5.5 ≤ D ≤ 6.5 mm (+0.25/-0.15 mm) with 0.50 mm intervals	Level or D+1 mm (+0.25/-0.15 mm with 0.50 mm intervals)	
6.9 +0.10/-0.20 mm			6.5 ≤ D ≤ 10 mm (+4%/-2.5% with 0.50 mm intervals)	Level or D+1 mm (+4%/-2.5% with 1 mm intervals)	
			10 ≤ D ≤ 12 mm (+4%/-2.5% with 1 mm intervals)		
			12 ≤ D ≤ 15 mm (+4%/-2.5% with 1 mm intervals)	Level only (+0.50/-0.50 mm)	

*With optional hot-melt (HM) adhesive • Note: total height will increase up to 0.5 mm if hot-melt requested

**With optional black non-woven (NW) silent fin

Colours						
Multifilament pile yarn colours						
Beige RAL 1011	Dark Gold RAL 1032	Grey RAL 7045	Pale Brown RAL 8025	Brown RAL 8028	White RAL 9003	Black RAL 9005

Dust-Plug (DP)

woven brush pile seals



Soft silicone treated multifilament pile yarn on a woven reinforced translucent backing. Available cut-to-size and in lengths for specific and generally wider sealing applications like in corners of sliding doors or furniture. Optional adhesive backing, fins and untreated monofilament edges.

Recommended compression:

- Standard (without fins): 15-20%
- Fin level with or lower than pile: 10-15%
- Fin higher than pile: 5-10%

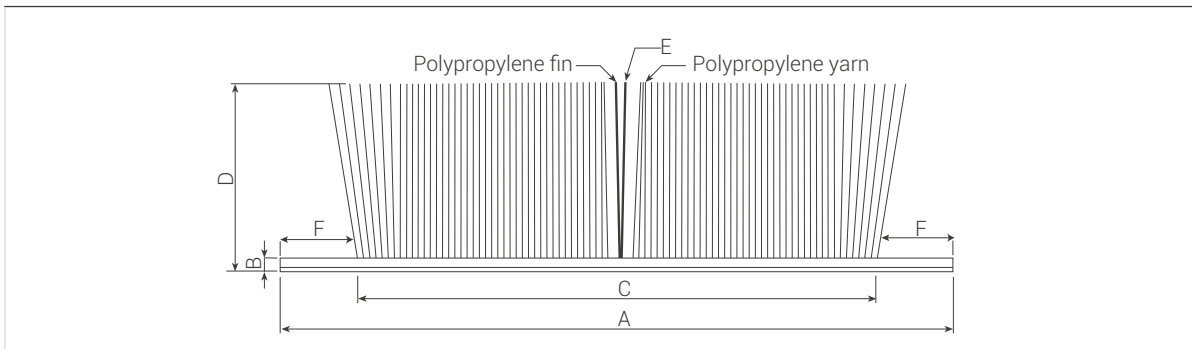

Standard solutions					
A Carrier width*	B Backing thickness	C Pile carrier width	D Brush and optional central fin height	E Brush density	F=A-C
10 ≤ L ≤ 60 ± 0.5 mm with 0.5 mm intervals	0.8 ± 0.15 mm	6 ≤ L ≤ 56 ± 1.0 mm	3 ≤ D ≤ 6.5 mm (+0.25/-0.15 mm) with 0.50 mm intervals	8P - 76P	Min. 2 mm
			6.5 < D ≤ 22 mm (+4%/-2.5% with 1 mm intervals)		
			Fin D > 5 mm (+0.25/-0.15 mm) with 0.50 mm intervals		
			Fin level only (+0.50/-0.50 mm)		

Other configurations upon request: • Strengthening monofilament edges • Fin alternatives under design
 *With optional hot-melt adhesive (HM). Note: total height will increase up to 0.5 mm if hot-melt requested.

Colours		
Multifilament pile yarn colours		
Black RAL 9005	Grey RAL 7045	White RAL 9003

Shutter-Pile (SP)

woven brush pile seals



Woven pile on a translucent backing. Soft silicone treated multifilament yarn, partially strengthened with stiffer untreated monofilament. It is typically inserted in T-slots of side guiding channels for sealing of roller shutters and similar products. Optional adhesive backing.

Recommended compression:

- Brush pile height from 3.0 to 15.0 mm: 15% to 20%



Dimensions			
	4.8	6.7	6.9
H	5.3	7.5	7.7
I	3.2	3.2	3.2
J	1.3	1.3	1.3
Minimum clearance recommended: +0.5 mm of backing width chosen			

Standard solutions				
A Backing width*	B Backing thickness	C Pile carrier width	D Brush height	E Brush density (P) in line (L) with monofilament (M)
4.8 +0.10/-0.15 mm	0.8 ± 0.15 mm	1.6 ± 0.3 mm	3.0 ≤ D ≤ 6.5 mm (+0.25/-0.15 mm) with 0.50 mm intervals	2P1L1M 3P1L1M
6.7 +0.10/-0.20 mm			6.5 < D ≤ 10.0 mm with 0.5 mm intervals (4%/-2.5% mm)	
6.9 +0.10/-0.20 mm			10.0 ≤ D ≤ 15.0 mm (+4%/-2.5% mm) with 1.0 mm intervals	

*With optional hot-melt (HM) adhesive • Note: total height will increase up to 0.5 mm if hot-melt requested

Colours	
Multifilament pile yarn colours	
Black RAL 9005	Grey RAL 7045

Colours	
Monofilament pile yarn colours	
Black RAL 9005	White RAL 9003

Power-Pile (PW)

extruded woven brush pile seals



Soft silicone treated multifilament pile yarn on an extruded base with upstanding directors. Guaranteed on centre pile, more suitable for machine insertion. Optional adhesive backing.

Recommended compression:

- Brush pile height from 3.0 to 5.0 mm: 5% to 10%
- Brush pile height from 5.5 to 6.5 mm: 10% to 20%
- Brush pile height from 7.0 mm and above: 15% to 25%



Dimensions			
	4.8	6.7	6.9
H	5.3	7.5	7.7
I	3.2	3.2	3.2
J	1.3	1.3	1.3
Minimum clearance recommended: +0.5 mm of backing width chosen			

Standard solutions					
A Backing width*	B Backing thickness	C Directors width	D Directors height	E Brush height	F Brush density (P)
4.8 ± 0.2 mm	0.65 ± 0.1 mm	2.5 ± 0.3 mm	2.4 ± 0.3 mm	5.0 ≤ E ≤ 8.0 mm (+0.50/-0.50 mm) with 0.50 mm intervals	4P
6.7 ± 0.2 mm				8.0 < E ≤ 25.0 mm (+0.50/-0.50 mm) with 1.0 mm intervals	
6.9 ± 0.2 mm					

*With optional hot-melt adhesive (HM) • Note: total height will increase up to 0.5 mm if hot-melt requested, binder thread not available with hot-melt

Colours						
Multifilament pile yarn colours						
Beige RAL 1011	Dark Gold RAL 1032	Grey RAL 7045	Pale Brown RAL 8025	Brown RAL 8028	White RAL 9003	Black RAL 9005

Fin-Pile (FP)

extruded woven brush pile seals



Soft silicone treated multifilament pile yarn on an extruded base with upstanding directors. Guaranteed on centre pile, more suitable for machine insertion. Two clear central fins keep the brush visually intact while providing improved weather sealing for sliding windows and doors. Optional adhesive backing.

Recommended compression:

- Brush pile height from 5.5 to 6.5 mm: 10% to 20%.
Level fin only
- Brush pile height from 7.0 to 6.5 mm: 15% to 25%



Dimensions			
	4.8	6.7	6.9
H	5.3	7.5	7.7
I	3.2	3.2	3.2
J	1.3	1.3	1.3
Minimum clearance recommended: +0.5 mm of backing width chosen			

Standard solutions						
A Backing width	B Backing thickness	C Directors width	D Directors height	E Brush height	F Fin height* (≥ 5 mm)	G Brush density (P)
4.8 ± 0.2 mm	0.65 ± 0.1 mm	2.6 ± 0.3 mm	2.6 ± 0.3 mm	5 ≤ E ≤ 8 mm (+0.50/-0.50 mm) with 0.50 mm intervals	Level only (+0.50/-0.50 mm)	4P
6.7 ± 0.2 mm				E ≤ 20 mm (+0.50/-0.50 mm) with 1 mm intervals		
6.9 ± 0.2 mm						

*With optional black non-woven (NW) silent fin

Colours						
Multifilament pile yarn colours						
Beige RAL 1011	Dark Gold RAL 1032	Grey RAL 7045	Pale Brown RAL 8025	Brown RAL 8028	White RAL 9003	Black RAL 9005

Soft silicone treated multifilament yarn on an extruded base. Guaranteed on centre pile, more suitable for machine insertion.

With clear central fin for improved weather sealing of sliding windows and doors.

Optional adhesive backing.

Recommended compression:

- Brush pile height from 4.0 to 5.0 mm:
5% to 10%.
Fin should be plus 1 mm
- Brush pile height from 5.5 to 6.5 mm:
10% to 20%.
Fin level or plus 1 mm
- Brush pile height from 7.0 to 11 mm:
15% to 25%.
Fin level or plus 1 mm
- Brush pile height from 12.0 mm and above:
15% to 25%.



	Dimensions		
	4.8	6.7	6.9
H	5.3	7.5	7.7
I	3.2	3.2	3.2
J	1.3	1.3	1.3
Minimum clearance recommended: +0.5 mm of backing width chosen			

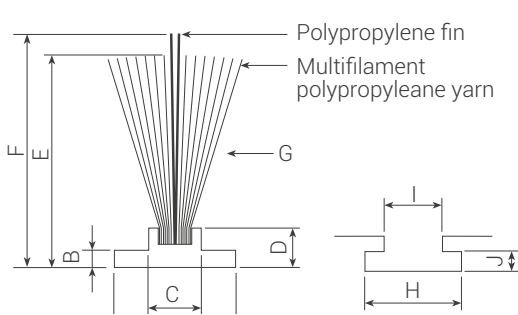

Standard solutions						
A Backing width	B Backing thickness	C Directors width	D Directors height	E Brush height	F Fin height* (≥ 5 mm)	G Brush density (P)
4.8 ± 0.2 mm 6.7 ± 0.2 mm 6.9 ± 0.2 mm	0.65 ± 0.1 mm	2.5 ± 0.3 mm	2.3 ± 0.2 mm	4 ≤ E ≤ 5 mm (+0.50/-0.50 mm) with 0.50 mm intervals	E+1 mm (+0.50/-0.50 mm)	4P
				5.5 ≤ E ≤ 8 mm (+0.50/-0.50 mm) with 0.50 mm intervals	Level or E+1 mm (+0.50/-0.50 mm)	
				8 ≤ E ≤ 12 mm (+0.50/-0.50 mm) with 1 mm intervals		
				12 ≤ E ≤ 20 mm (+0.50/-0.50 mm) with 1 mm intervals	Level fin only (+0.50/-0.50 mm)	

*With optional black non-woven (NW) silent fin

Colours						
Multifilament pile yarn colours						
Beige RAL 1011	Dark Gold RAL 1032	Grey RAL 7045	Pale Brown RAL 8025	Brown RAL 8028	White RAL 9003	Black RAL 9005

G3-QF (Quadrafin)

extruded woven brush pile seals



Soft silicone treated multifilament yarn on an extruded base. Guaranteed on centre pile, more suitable for machine insertion. With clear central and external fins for improved weather sealing of sliding windows and doors. Optional adhesive backing.

Recommended compression:

- Brush pile height from 5.0 to 6.5 mm: 10% to 20%.
Fin level or plus 1 mm
- Brush pile height from 7.0 to 11 mm: 15% to 25%.
Fin level or plus 1 mm
- Brush pile height from 12.0 to 15 mm: 15% to 25%.
Level fin only



	Dimensions		
	4.8	6.7	6.9
H	5.3	7.5	7.7
I	3.2	3.2	3.2
J	1.3	1.3	1.3
Minimum clearance recommended: +0.5 mm of backing width chosen			

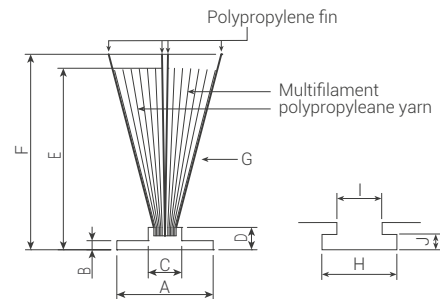

Standard solutions						
A Backing width	B Backing thickness	C Directors width	D Directors height	E Brush height	F Central and outside Fin height* (≥ 6 mm)	G Brush density (P)
4.8 ± 0.2 mm	0.65 ± 0.1 mm	2.5 ± 0.2 mm	1.2 ± 0.2 mm	6 ≤ E ≤ 10 mm (+0.50/-0.50 mm with 0.50 mm intervals)	Level or E+1 mm (+0.50/-0.50 mm)	4P
6.7 ± 0.2 mm				10 ≤ E ≤ 12 mm (+0.50/-0.50 mm with 1 mm intervals)		
6.9 ± 0.2 mm						

*With optional black non-woven (NW) silent fin

Colours								
Multifilament pile yarn colours						NW fin Colours		
Beige RAL 1011	Dark Gold RAL 1032	Grey RAL 7045	Pale Brown RAL 8025	Brown RAL 8028	White RAL 9003	Black RAL 9005	Silver Grey RAL 7001	Black RAL 9005

Bi-Fin (BF)

extruded woven brush pile seals



Soft silicone treated multifilament pile yarn on an extruded base with upstanding directors. Guaranteed on centre pile, more suitable for machine insertion.
A clear lateral fin ensures side protection of the yarn and improves weather sealing for sliding applications. Optional adhesive backing.

Recommended compression:

- Brush pile height from 6.0 to 8.0 mm: 10% to 20%.
Level fin only
- Brush pile height from 8.0 and above: 15% to 25%



Dimensions				
	4.8	6.7	6.9	
H	5.3	7.5	7.7	
I	3.2	3.2	3.2	
J	1.3	1.3	1.3	
Minimum clearance recommended: +0.5 mm of backing width chosen				

Standard solutions						
A Backing width	B Backing thickness	C Directors width	D Directors height	E Brush and central fin height	F External fin height* (≥ 5 mm)	G Brush density (P)
4.8 ± 0.2 mm	0.65 ± 0.1 mm	2.6 ± 0.3 mm	2.4 ± 0.3 mm	6 ≤ E ≤ 8 mm (+0.50/-0.50 mm) with 0.50 mm intervals	Level fin only (+0.50/-0.50 mm)	4P
6.7 ± 0.2 mm				8 ≤ E ≤ 20 mm (+0.50/-0.50 mm) with 1 mm intervals		
6.9 ± 0.2 mm						

*With optional black non-woven (NW) silent fin

Colours						
Multifilament pile yarn colours						
Beige RAL 1011	Dark Gold RAL 1032	Grey RAL 7045	Pale Brown RAL 8025	Brown RAL 8028	White RAL 9003	Black RAL 9005

Angle-Pile (AP)

extruded woven brush pile seals



Untreated monofilament yarn with extruded base. Available in 45° or 60° angles, Guaranteed on centre pile, more suitable for machine insertion. Predominantly applied in side guiding channels of rolling insect screens. Install single with softer standard pile, or double, to hold the screen mesh in the guides.

Recommended compression:

- 15-20%.



Dimensions		
	4.8	6.9
H	5.3	7.7
I	3.2	3.2
J	1.3	1.3

Minimum clearance recommended: +0.5 mm of backing width chosen

Standard solutions				
A Carrier width	B Backing thickness	C Brush height	D Angles	E Brush density
4.8 ± 0.2 mm	0.65 ± 0.15 mm	9.0 ≤ D ≤ 12.0 + 0.5 mm with 0.50 mm intervals	45 ± 5°	24
6.9 ± 0.2 mm		12.0 < C ≤ 25.0 + 0.5 mm with 1.0 mm intervals	60 ± 5°	

Colours		
Multifilament pile yarn colours		
Black RAL 9005	Grey RAL 7045	White RAL 9003

Skirting-Fringe (SF)

extruded woven brush pile seals



Extruded square or round base for sealing of gaps at the edges of swing doors, roller shutters and other similar narrow profile applications. Stiffer untreated 6-ply monofilament or softer silicone treated multifilament yarn. Other base shapes and dimensions are available upon request.

Recommended compression:

- 15-20%

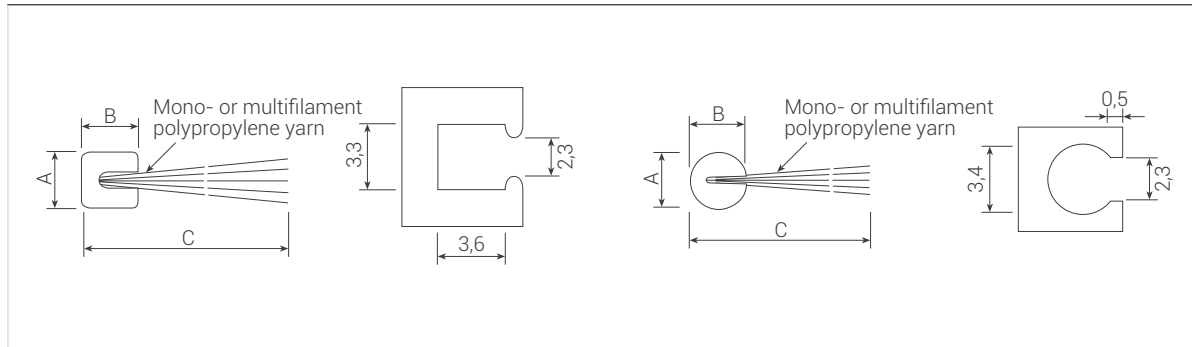

Standard solutions			
A Carrier width	B Carrier height	C Brush height	D Brush density
Square 2.7 ± 0.15 mm	2.7 (+0.15 / -0.35) 2.9 (+0.15 / -0.35) 3.1 (+0.15 / -0.35) 3.3 (+0.15 / -0.35)	5.0 ≤ D ≤ 30.0 + 0.5 mm with 1.0 mm intervals	Monofilament 24 Multifilament 4P
Square 2.9 ± 0.15 mm			
Square 3.1 ± 0.15 mm			
Square 3.3 ± 0.15 mm			
Round 2.7 ± 0.15 mm			
Round 2.9 ± 0.15 mm			
Round 3.1 ± 0.15 mm			
Round 3.3 ± 0.15 mm			

Colours	
Multifilament pile yarn colours	
Black RAL 9005	Grey RAL 7045

Colours	
Monofilament pile yarn colours	
Black RAL 9005	Natural

Flex-Brush (FB)

coilable brush pile seals

Extruded square base for sealing of revolving doors, escalators, industrial doors and garage doors. Monofilament yarn available in polypropylene. Also available in Polyamide 6 with special conditions on minimum order quantity, lead time and price. Other carrier shapes and dimensions are available upon request.

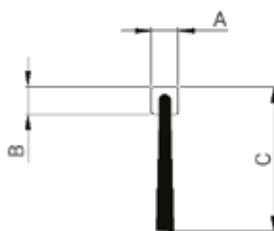

Standard solutions

A Carrier width	B Carrier height	C Brush height	Brush density
3 mm	3 mm	10 – 50 mm (with 1 mm intervals)	SD15
3.5 mm	3.5 mm		
4 mm	4 mm		HD15
4.5 mm	4.5 mm		

Colours

Polypropylene colours

Black
RAL 9005

Grey
RAL 7045

Kerf-Pile (KP)

extruded brush pile seals

Soft silicone treated multifilament pile yarn on a dedicated extruded base designed to fit a timber groove.
Easy insertion and excellent sealing.

Recommended compression:

- 15-20%

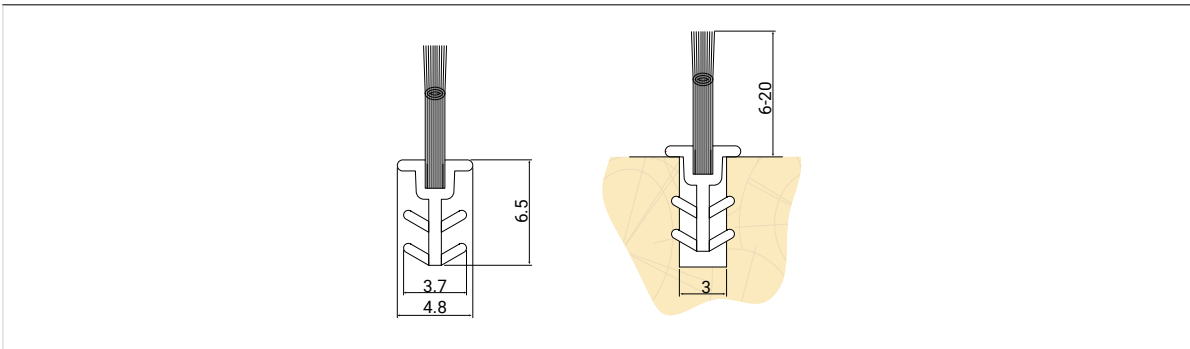

Standard solutions

Groove width	Min. groove depth	Brush height	Brush density
3 mm	7 mm	$6.0 < H \leq 20.0$ mm (+0.50/-0.50 mm) with 1.0 mm intervals	5P

Colours

Multifilament pile yarn				
White RAL 9003	Silver Grey RAL 7045	Black RAL 9005	Brown RAL 8028	Beige RAL 1011

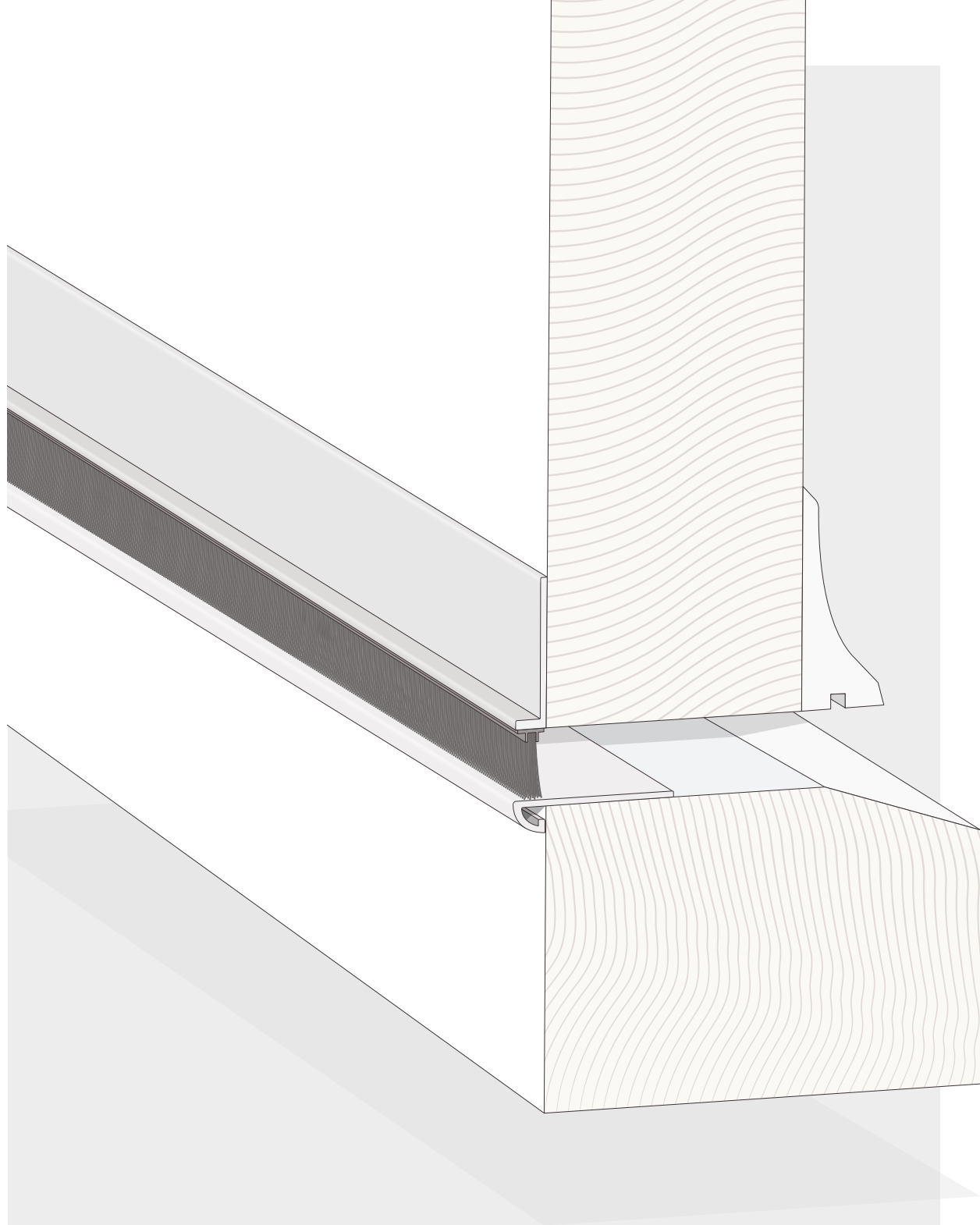

Combination brush pile seals

- Rigid ABS, PP or PVC extrusion for universal surface or kerf-slot fitting
- Fitted with brush pile according to specification
- Alternatively extruded profile for retro-fit with brush pile in coils

For universal surface fitting

Poly-Bond on extruded PVC, PP or ABS carrier

<p>PB 1126</p> <p>Seal gap: 8.0 - 15.0 Pack size: 50 m x 2</p>	
Doors	

<p>PB 1127</p> <p>Seal gap: 11.0 - 23.0 Pack size: 50 m x 4 50 m x 3 45 m x 3</p>	
Doors	

<p>PB 1421</p> <p>Seal gap: 4.0 - 4.5 Pack size: 2.088 m x 250</p>	
Doors	

For kerf-slot fitting

Poly-Bond on extruded PVC, PP or ABS carrier

<p>PB 0908</p> <p>Groove width: 3.0 Min. groove depth: 10.0 Seal gap: 2.0 - 13.0 Pack size: 2.1 m x 250</p>	
Doors	

<p>PB 1001</p> <p>Groove width: 3.0 Min. groove depth: 6.0 Rebate: 9.5 Seal gap: 4.0 - 15.0 Pack size: 150 m x 1</p>	
Timber sliding windows	

<p>PB 1002</p> <p>Groove width: 3.0 Min. groove depth: 6.0 Rebate: 11.8 Seal gap: 4.0 - 15.0 Pack size: 150 m x 1</p>	
Timber sliding windows	

<p>PB 1003</p> <p>Groove width: 3.0 Min. groove depth: 6.0 Rebate: 7.5 Seal gap: 4.0 - 15.0 Pack size: 100 m x 1</p>	
Timber sliding windows	

<p>PW 1018 FLEX PW 1018 FLEX</p> <p>Groove width: 3.0 Min. groove depth: 7.0 Seal gap: 4.0 - 15.0 Pack size: 200 m x 1 2.1 m x 300</p>	
Timber sliding doors	



PB 1021

Groove width: **3.0 nom. (B1); 2.5 min. to 3.8 max. (B2)**
 Min. groove depth: **7.0**
 Rebate: **7.5**
 Seal gap: **4.0 - 15.0**
 Pack size: **400 m x 1**

Aluminium sliding doors

PB 1372

Groove width: **3.0**
 Min. groove depth: **7.0**
 Pack size: **650 m x 1**

RX

PB 1451

Groove width: **3.0**
 Min. groove depth: **7.0**
 Pack size: **650 m x 1**

LX

PB 1466

Groove width: **3.0**
 Min. groove depth: **7.0**
 Pack size: **650 m x 1**

Dust filter

Carriers for brush pile seals

LV 0921 27256

Groove width: **10.0**
 Min. groove depth: **4.0**
 Pack size: **50 m x 100**

C-channel
10 x 4 with 6.7 brush insert

LV 3015 27797

Pack size: **2.6 m x 100**

L-profile carrier
7 x 26 with 4.8 brush insert

LV 3016 27809

Pack size: **1.0 m x 100**

L-profile carrier
10 x 26 with 6.7 brush insert

LV 5032 27853

Groove width: **4.0**
 Min. groove depth: **10.0**
 Pack size: **50 m x 9**

Kerf-slot carrier
7 x 9 with 4.8 brush insert

LV 5438 27900

Groove width: **3.0**
 Min. groove depth: **8.0**
 Pack size: **2.2 m x 200**

Kerf-slot carrier
7 x 7 with 4.8 brush insert

LV 5594 27923

Groove width: **7.1**
 Min. groove depth: **3.5**
 Pack size: **2.1 m x 100**

Adhesive C-channel with 4.8 brush insert

EASE OF INSERTION

Reinforced fabric backing, extruded base or
carrier profile for optimum ease of insertion.

Schlegel
TYMAN group

Extruded seals

For timber, aluminium and PVC applications

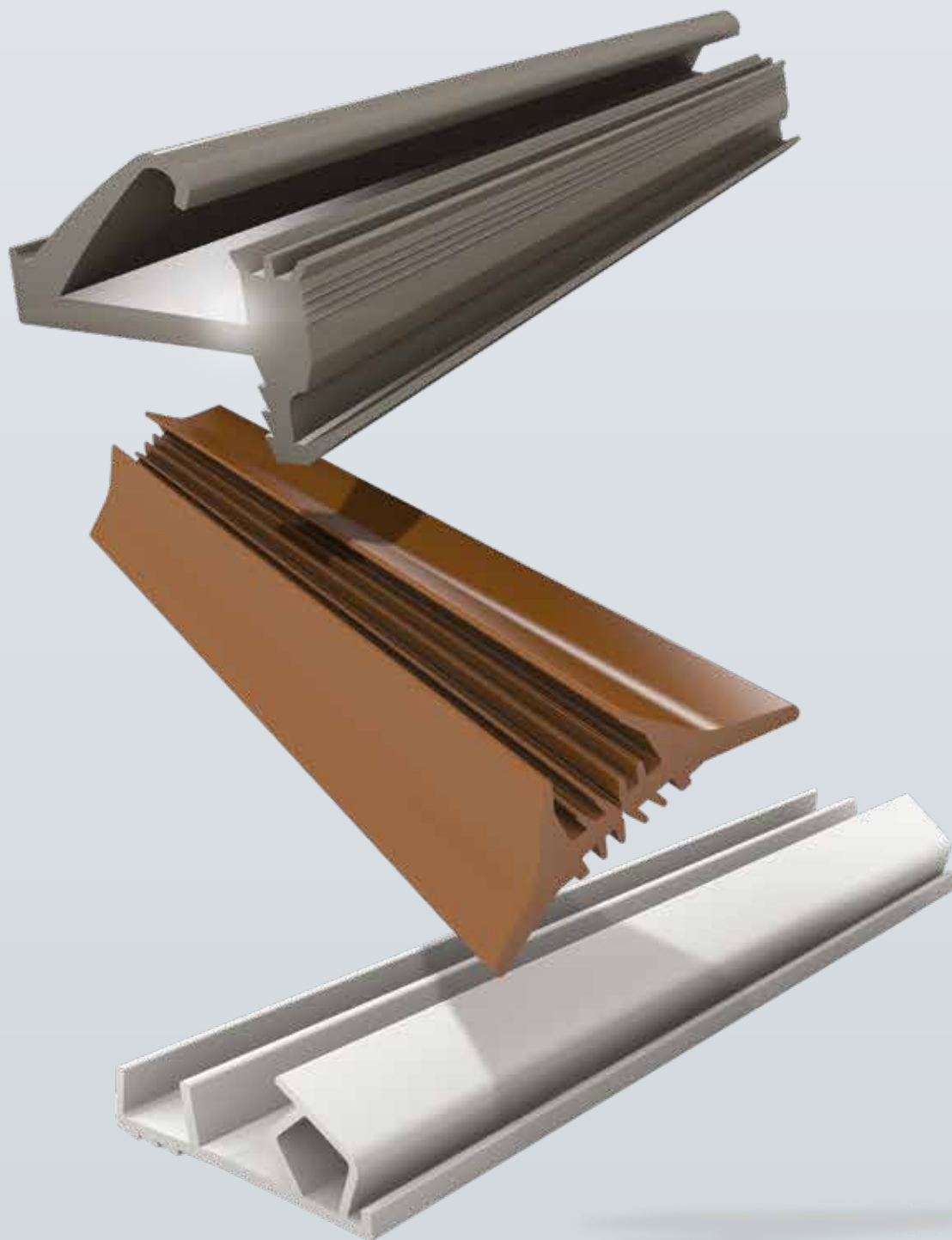

Q-LON

Brush pile

Extruded



Index

Materials and colours	82
Classifications	85
Technical specifications	
Lozaron. Extruded profiles for timber doors and windows	86
Lozaron. Extruded profiles for aluminium doors and windows	88
Shutters and screens	92

Materials and colours

Schlegel extruded seals are made from various extruded materials and can be combined with foam seals.

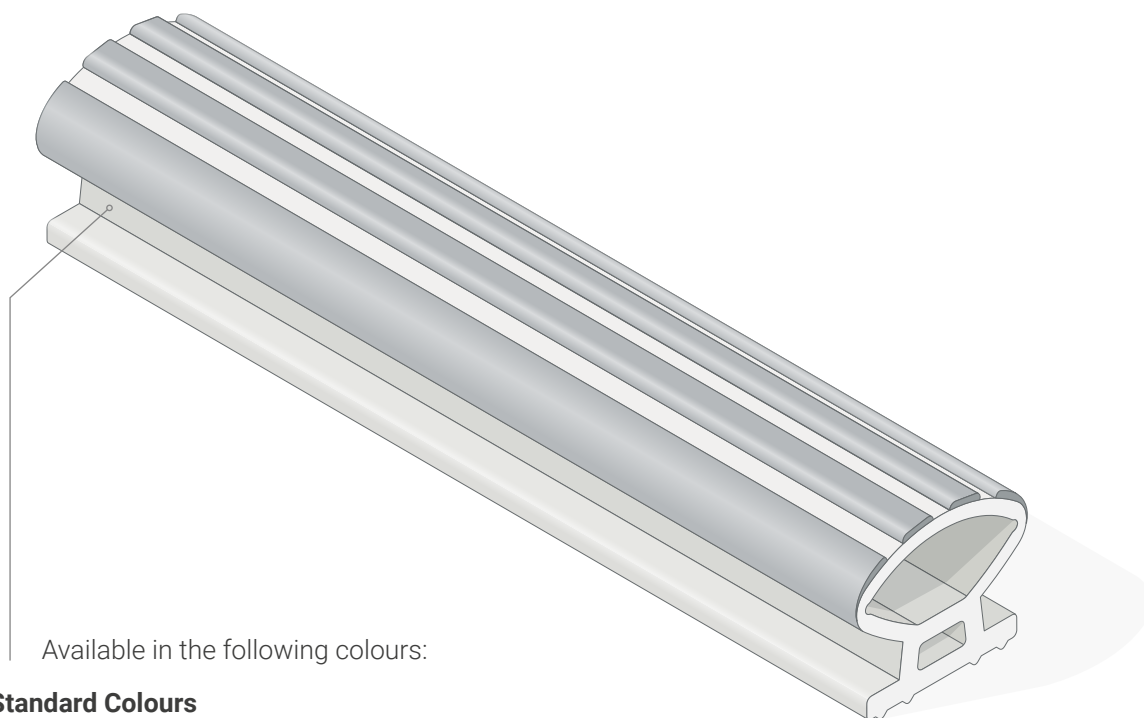

Available in the following colours:

Standard Colours

- BRONZE / RAL 8019 / Code 285
- WHITE / RAL 9003 / Code 287
- BLACK / RAL 9005 / Code 288

Extra Colours

- TRANSLUCENT / RAL - / Code 200
- PAPYRUS WHITE / RAL 9018 / Code 265
- GRAPHITE BLACK / RAL 9011 / Code 268
- BEIGE / RAL 1001 / Code 270
- SILVER GREY / RAL 7001 / Code 271
- GRAPHITE GREY / RAL 7024 / Code 273
- PEBBLE GREY / RAL 7032 / Code 274
- LIGHT GREY / RAL 7035 / Code 275
- DUSTY GREY / RAL 7037 / Code 276
- OCHRE BROWN / RAL 8001 / Code 278
- CHESTNUT BROWN / RAL 8015 / Code 282
- CHOCOLATE BROWN / RAL 8017 / Code 284

For the standard colours for each item, please refer to the separately available customer drawings on our website.

Lozaron (LF) (LP) (LT) (LV)

Lozaron seals consist of a range of TPE, foamed TPE, polypropylene, EPDM and PVC profiles.

- Lozaron TPE extrusions with flexible microcell foam (LF)
- Lozaron TPE extruded profiles without foam (LT)
- Polypropylene (LP) and PVC (LV) extrusions

In our range of extruded seals, a variety of materials and manufacturing processes are combined to achieve the optimal combination of product characteristics.

Lozaron extrusions are made of different plastic compounds and can be combined with the Poly-Bond brush pile and Q-LON foam technologies as outlined.

WIDE RANGE OF COLOURS



Schlegel extruded seals come
in a huge range of colours.

Schlegel
TYMAN group



WIDE RANGE OF MATERIALS

Schlegel extruded seals are made from the best material to suit each application.

Schlegel
TYMAN group

Classifications

Weatherseals compliant with **EN 12365 2003**

Under EN 12365 2003 there is a prescribed classification system that enables window, door, shutter and curtain walling manufacturers or installers to ensure that they are using the component that best meets their requirements.

A six-digit system is used

1	2	3	4	5	6
Category of use	Working range	Linear compression force	Working temperature range	Deflection recovery	Recovery after ageing
W = Weatherstrip G = Gasket	9 grades showing the working range of the seal; 9 indicates the greatest distance	9 grades showing the linear compression force; 9 indicates the greatest force	6 grades showing the operating temperature range, each with different maximum and minimum temperatures	8 grades showing deflection recovery; grade 0 indicates no requirement and grade 7 shows the greatest recovery	8 grades showing recovery after ageing; grade 0 indicates no requirement and grade 7 shows the greatest recovery

Grades

1: ≤ 1 mm 2: >1 mm ≤ 2 mm 3: >2 mm ≤ 4 mm 4: >4 mm ≤ 6 mm 5: >6 mm ≤ 8 mm 6: >8 mm ≤ 10 mm 7: >10 mm ≤ 15 mm 8: >15 mm ≤ 30 mm 9: >30 mm	1: ≤ 10 N/m 2: >10 N/m ≤ 20 N/m 3: >20 N/m ≤ 50 N/m 4: >50 N/m ≤ 100 N/m 5: >100 N/m ≤ 200 N/m 6: >200 N/m ≤ 500 N/m 7: >500 N/m ≤ 700 N/m 8: >700 N/m ≤ 1000 N/m 9: >1000 N/m	1: 0°C to +45°C 2: -10°C to +55°C 3: -20°C to +85°C 4: -25°C to +100°C 5: -40°C to +70°C 6: 0°C to +200°C	0: No requirements 1: >30% to 40% 2: >40% to 50% 3: >50% to 60% 4: >60% to 70% 5: >70% to 80% 6: >80% to 90% 7: >90%	0: No requirements 1: >30% to 40% 2: >40% to 50% 3: >50% to 60% 4: >60% to 70% 5: >70% to 80% 6: >80% to 90% 7: >90%
--	--	--	---	---

A typical classification looks like this

W	3	4	2	4	3
---	---	---	---	---	---

Code	EN 12365
LT 1305	W33221
LT 1432	W34243
LT 1509	W24521
LT 1515	W15232





- LE** Lozaron EPDM seals
- LT** Lozaron foamed TPE seals
- LP** Lozaron PP seals
- LV** Lozaron PVC seals

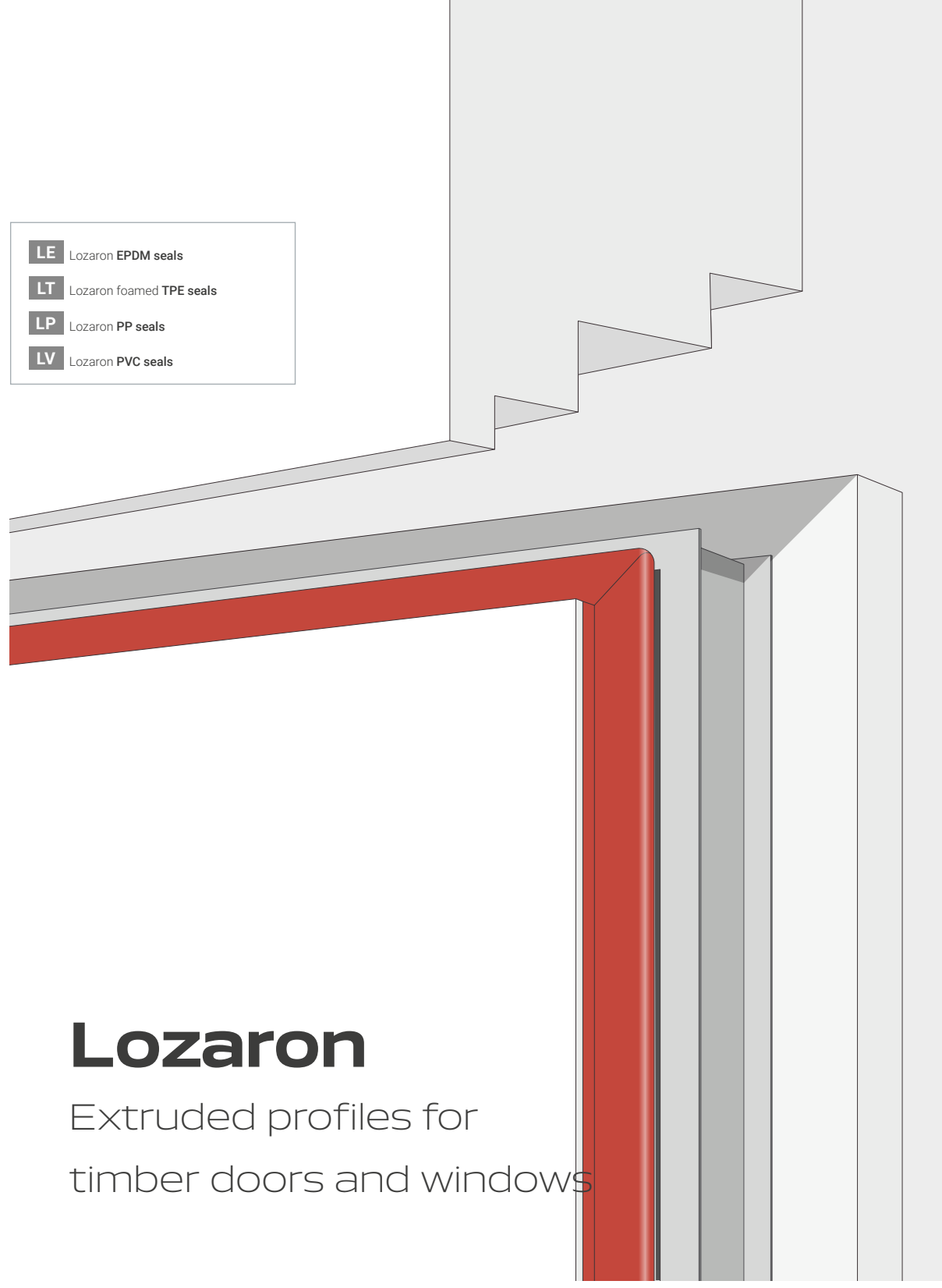

Lozaron

Extruded profiles for
timber doors and windows

LF 1105	23010	
Groove width: 1.5 - 2.2 Min. groove depth: 11.5 Pack size: 400 m x 2		
Cover profile for dry glazing		

LP 1034	24010	
Groove width: 0.7 - 0.8 Pack size: 400 m x 1		
Cover profile for dry glazing		

LP 1057	24091	
Groove width: 3.0 Min. groove depth: 6.0 Rebate: 11.0 Seal gap: 4.0 - 5.5 Pack size: 800 m x 1		
Casement seal		

LP 1101	24171	
Groove width: 4.0 Min. groove depth: 6.0 Seal gap: 4.0 - 7.0 Pack size: 300 m x 1		
Centre seal		

LT 1362	26020	
Groove width: 5.0 Min. groove depth: 8.0 Rebate: 12.0 / 19.0 Pack size: 25 m x 1 150 m x 1		
Profile for doors and windows		

LT 1430	26350	
Groove width: 5.0 Min. groove depth: 7.0 Rebate: 15.0 Seal gap: 5.0 Pack size: 130 m x 1		
Door sealing profile		

LT 1432	26571	
Groove width: 5.0 Min. groove depth: 8.0 Rebate: 12.0 Seal gap: 5.0 Pack size: 150 m x 1		
Sealing profile		

LV 1481	27670	
Groove width: 4.0 Min. groove depth: 6.0 Rebate: 12.0 Seal gap: 5.0 Pack size: 120 m x 1		
Sealing profile		

LT 1489	26891	
Groove width: 3.0 Min. groove depth: 7.0 Pack size: 300 m x		
Double window seal		

LV 0959	27437	
Groove width: 3.0 - 4.0 Min. groove depth: 7.0 Rebate: 17.0 Seal gap: 4.0 - 5.0 Pack size: 165		
Door threshold profile		

LV 1102	27370	
Groove width: 2.8 - 3.5 Min. groove depth: 6.5 Rebate: 12.0 Seal gap: 3.5 - 5.0 Pack size: 80 m x 4		
Double window seal		

LV 1140	27003	
Groove width: 6.35 Min. groove depth: 10.0 Rebate: 17.0 Seal gap: 5.0 - 8.0 Pack size: 50		
Door sealing profile		

LV 1305	27555	
Groove width: 4.0 Min. groove depth: 5.0 Seal gap: 5.0 - 7.0 Pack size: 45 m x 7 60 m x 10 300 m x 1		
Window sealing profile		

F Suitable for Frame Seal S Suitable for Sash Seal O Suitable for Overlap Seal C Suitable for Centre Seal



Q-LON

Brush pile

Extruded

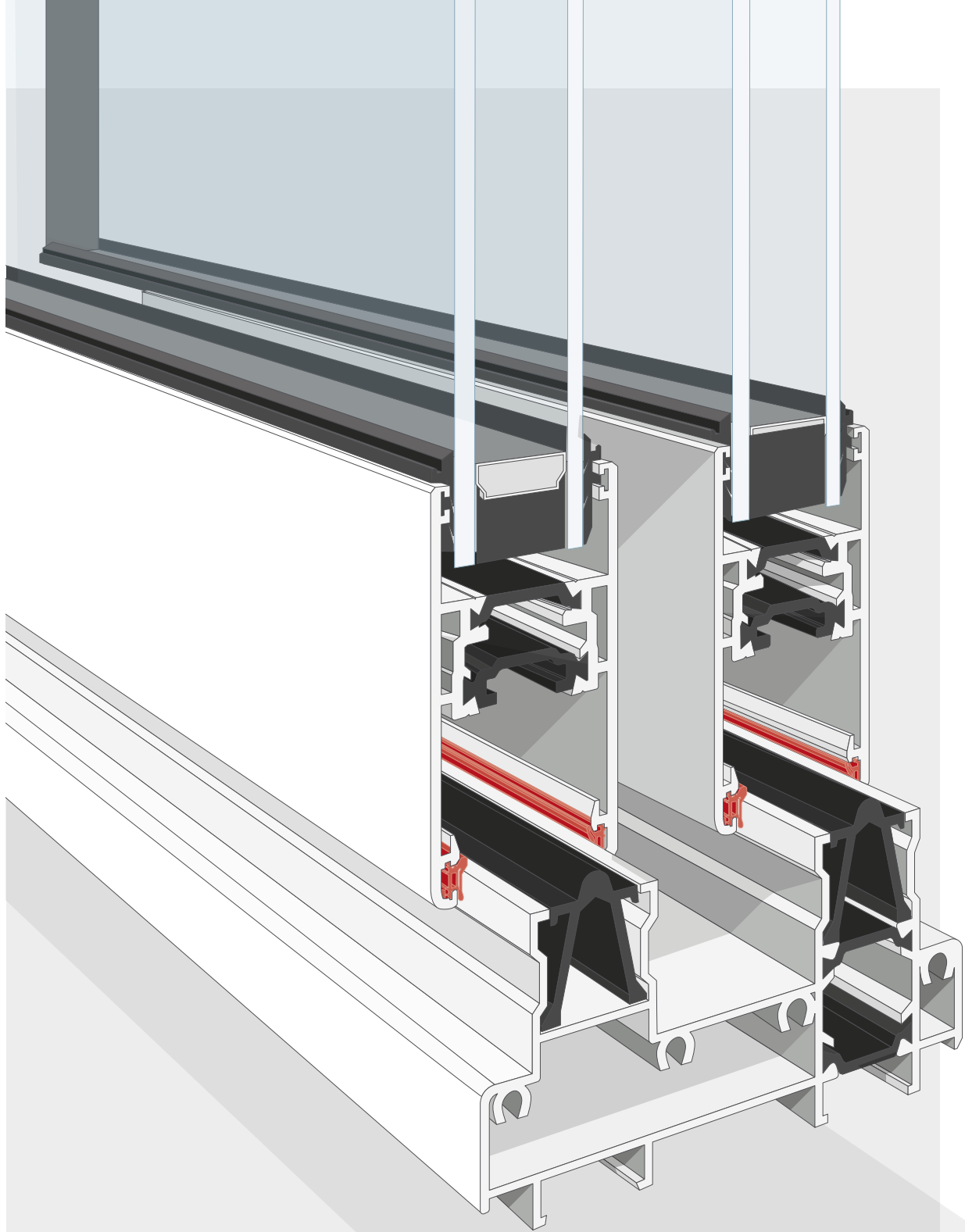

Lozaron Aluminium

Applications on aluminium
doors and windows

For aluminium sliding doors

LT 1509	26990	
Throat width: 4.0 - 4.5 Groove width: 5.0 Seal gap: 3.0 Pack size: 250 m x 1		
Sliding seal		
W24521		
LT 1515	26993	
Throat width: 3.2 Groove width: 5.4 Seal gap: 2.6 - 2.9 Pack size: 250 m x 1		
Sliding seal		
W15232		

For aluminium dry glazing

LE 611 FV2	22305	
A - Seal gap: 2.0 Pack size: 500 m x 1		
Glazing bead seal		

LE 727 FV3	22310	
A - Seal gap: 3.0 Pack size: 400 m x 1		
Glazing bead seal		

LE 768 FV4	22315	
A - Seal gap: 4.0 Pack size: 250 m x 1		
Glazing bead seal		

LE 1009 FV5	22320	
A - Seal gap: 5.0 Pack size: 150 m x 1		
Glazing bead seal		

LE 1162 FV6	22325	
A - Seal gap: 6.0 Pack size: 150 m x 1		
Glazing bead seal		

LE 1232 FV7	22330	
A - Seal gap: 7.0 Pack size: 100 m x 1		
Glazing bead seal		

LE 1325 FV8	22335	
A - Seal gap: 8.0 Pack size: 100 m x 1		
Glazing bead seal		

LE 1670 FV10	22340	
A - Seal gap: 10.0 Pack size: 100 m x 1		
Glazing bead seal		

IN ALL SHAPES



Schlegel extruded seals can be configured with geometries ranging from the simplest to the most specific shapes.

Schlegel
TYMAN group



Q-LON

Brush pile

Extruded

Shutters and screens

For roller shutters, screens and window covering products

LP 1040	24030
Pack size: 500 m x 1	
Side guiding shutter profile	

LP 1077	26015
Groove width: 2.5 - 6.0	
Min. groove depth: 1.2	
Seal gap: 4.5 - 6.0	
Pack size: 400 m x 1	
Bottom bar seal	

LP 1088	24151
Groove width: 4.0 - 8.0	
Min. groove depth: 1.2	
Pack size: 400 m x 1	
Roller shutter T-profile	

LP 1102	27370
Pack size: 400 m x 2	
Side guiding shutter profile	

LV 1194	27364
Pack size: 2.5 m x 50	
Cover profile	

LV 1215	27483
Pack size: 2.5 m x 50	
Cover profile	

LV 1417	27599
Groove width: 3.0 - 8.0	
Min. groove depth: 1.2	
Pack size: 350 m x 1	
Side guiding sealing profile	

LV ZIP	
Pack size: 6.0 m x 40	
ZIP screen profile (design to order)	

DIFFERENT DENSITIES



Schlegel extruded seals come in three different densities and materials, which can be mixed and matched for optimal performance.

Schlegel
TYMAN group



Colours Appendix

Q-LON: polyurethane foam seals

Colour	RAL Code	Schlegel Code
Standard Colours		
White	9003	222
Silver	7001	212
Brown	8019	220
Black	9005	223

Colour	RAL Code	Schlegel Code
Extra Colours		
Beige	1001	211
Light Oak	8003	217
Fawn Brown	8007	218
Pure White	9010	221
Light Grey	7035	215
Pebble Grey	7032	213
Graphite Grey	7024	214

Brush pile seals and sealing profiles

Colour	RAL Code	Schlegel Code
Standard Colours Monofilament		
Grey	7045	277
Black	9005	288
Neutral	-	000
Standard Colours Multifilament		
Beige	1011	241
Dark Gold	1032	292
Grey	7045	277
Pale Brown	8025	291

Colour	RAL Code	Schlegel Code
Brown	8028	264
White	9003	287
Extra Colours Multifilament		
Ivory	1015	266
Iron Grey	7011	240
Dark Beige	8008	244
Sepia Brown	8014	281

Extruded seals

Colour	RAL Code	Schlegel Code
Standard Colours		
Bronze	8019	285
White	9003	287
Black	9005	288
Extra Colours		
Translucent	-	200
Papyrus white	9018	265
Graphite Black	9011	268
Beige	1001	270

Colour	RAL Code	Schlegel Code
Silver Gray	7001	271
Graphite Grey	7024	273
Pebble Grey	7032	274
Light Grey	7035	275
Dust Gray	7037	276
Ochre Brown	8001	278
Chestnut Brown	8015	282
Chocolate	8017	284

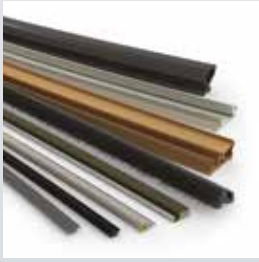

Schlegel

High performance sealing solutions



GIESSE

Innovative engineered hardware



REGUITTI

Italian design handles



JATEC

Timeless exclusive handles

