

INNOVATIVE ENGINEERED **HARDWARE**

GENERAL TECHNICAL CATALOGUE



HINGES FOR DOORS AND WINDOWS

HINGES FOR WINDOWS

FLASH BASE HINGES	2
FLASH BASE 3-WING HINGE	5
FLASH HINGES	6
SASH HINGE SET FOR CHIC 3D 100	8
FLUSH CHIC 3D 100 SASH HINGE KIT	10
SASH HINGE SET FOR CHIC 3D 130	12
CHIC 3D 150 SASH HINGE SET	14
SASH HINGE SET FOR CHIC 3D 130 ERRE	16
CHIC HINGES FOR BOTTOM-HUNG WINDOWS	18
CHIC ERRE HINGES FOR BOTTOM-HUNG WINDOWS	20
INVISIBLE SASH HINGE KIT	22
HINGES FOR BOTTOM-HUNG WINDOWS	24

CLAMP DOOR HINGES

BRIDGE 2 HINGES	25
CELERA HINGES	26
FULCRA HINGES	27
FLASH XXL HINGES	28
FLASH XLR HINGES	30
FLASH SLR HINGES	32

FRONTAL APPLICATION DOOR HINGES

BRIDGE HINGES	33
DOMINA CLASSIC HINGE	34
DOMINA HP HINGE	37
DOMINA HP HINGE, CORNER	40
DOMINA HP HINGE, COVER	43
DOMINA STEPS	46
COUNTERPLATE KIT	47
DIRECT FIXING SCREWS	48
EXPANSION DOWELS	49
TT PROFILE SPACERS	50
DOMINA HP SECURITY SYSTEM	51
HINGE MACHINING TEMPLATES	53
DOMINA ASSEMBLY EQUIPMENT	54

CONCEALED HINGES FOR DOOR

CHIC DOOR 160 HINGE	55
CHIC DOOR REINFORCEMENT KIT	59
CHIC DOOR INSTALLATION KIT	60
CHIC DOOR EG HINGES	61
CHIC DOOR RG HINGES	62

PIVOT HINGES

TECH PIVOT HINGES	63
FRIBLOK PIVOT HINGES	65

MECHANISMS AND FASTENERS

SUPRA 7

SUPRA 7 - MECHANISMS	68
SUPRA 7 - MECHANISM WITH OFFSET HANDLE	70
SUPRA 7 - DOUBLE WINDOW HANDLES	72
SUPRA 7 - DRILLING TEMPLATE	74

NP SUPRA

NP SUPRA - ASIA WINDOW HANDLE	76
NP SUPRA - PRIMA WINDOW HANDLE	77
NP SUPRA - TILT-AND-TURN HARDWARE	78
NP SUPRA - SASH HARDWARE	79
NP SUPRA - DRILLING TEMPLATE	80

CREMONES

KORA CREMONE	81
KORA KEY CREMONE	83
KORA 0-180 CREMONE	85
KORA KEY 0-180 CREMONE	86
KORA CW CREMONE	87
KORA 0-90 CREMONE	88
KORA 0-90 OUTWARD OPENING KIT	89
EURO CREMONE	90
EURO KEY CREMONE	93
EURO UNIVERSAL CREMONE	95
EURO AWAY CREMONE	97
EURO CW CREMONE	99
EURO CREMONE FOR PARALLEL CURTAIN WALL	101

PRIMA CREMONE	102
PRIMA KEY CREMONE	104
PRIMA UNIVERSAL CREMONE	106
ASIA CREMONE	108
ASIA KEY CREMONE	110
ASIA UNIVERSAL CREMONE	112
ASIA AWAY CREMONE	113
ASIA PLUS OUTWARD 0-90° CREMONE	115
ASIA PLUS 0-90 OUTWARD OPENING KIT	116
PULL DEVICES	117
ESSEN CREMONE	118
UNICA CREMONE	120
PULL DEVICES	123
CONNECTION PINS	124
UNICA KEY CREMONE	125
UNICA AWAY CREMONE	126
UNICA CW 2 CREMONE	128
NOVA CREMONE	129
SUPERNOVA CREMONE	131
COUPE' CREMONE	132
SHIMS AND STEPS	133
STOP BLOCK	134
DRIVE ROD COMPONENTS	135
CONNECTING KIT	136
CONNECTION PINS	139
BLANK CREMONE ASSEMBLY	140
WINDOW HANDLES	141
ASIA WINDOW HANDLE	141
PRIMA PLUS WINDOW HANDLE	142
KORA WINDOW HANDLE	144
KORA OFFSET WINDOW HANDLE	145
GAIA WINDOW HANDLE	148
GAIA OFFSET WINDOW HANDLE	149
BAS WINDOW HANDLE	150
COMPA WINDOW HANDLE	151
INTERNAL MECHANISMS	152
TWO-WAY INTERNAL MECHANISMS	152
ONE-WAY INTERNAL MECHANISMS	154
TWO-WAY MECHANISM FOR GHIBO OUT OUTWARD OPENING	156
ONE-WAY MECHANISM FOR GHIBO OUT OUTWARD OPENING	158
GHIBO ONE-WAY M180 OUTWARD OPENING MECHANISMS	161
ONE-WAY MOVEMENT GHIBO PLUS CW1	163
DOOR HANDLES	165
PRIMA PLUS HANDLE	165
MASTERMONT HANDLE	166
ASIA HANDLE	167
KORA DOOR HANDLES	168
MASTER PLUS HANDLE	169
MASTERPLAST HANDLE	171
CYLINDER COVER PLATES	172
GHIBO OUT KEY CYLINDER COVER PLATE	174
DOOR LOCKS	175
LOCKS FOR TOP-BOTTOM LOCKING	175
LOCKS FOR PERIMETER LOCKING	177
LOCKS WITH SPRING LATCH	179
LOCKS WITH DEAD BOLT AND SPRING LATCH	180
ROLLER AND BOLT LOCKS	181
MULTIPOINT LOCKS FLAT FRONT	182
MULTIPOINT DOOR LOCKS U-SHAPED FRONT	183
COUNTERPLATES	184
DOOR CYLINDERS	187
EUROPEAN PROFILE DOUBLE CYLINDER	187
HALF CYLINDER EUROPEAN PROFILE	189
EUROPEAN PROFILE CYLINDER WITH KNOB	190
HALF CYLINDER WITH KNOB	192
EVO DESIGN	194
BRASS WINDOW HANDLES	194
BRASS HANDLES	195
BRASS PLATES	197
UNICA SYSTEM	198
KORA CREMONE	199
UNICA SYSTEM CREMONE	199
UNICA SYSTEM CREMONE KIT	205
UNICA SYSTEM OUTWARD OPENING KIT	207
UNICA SYSTEM INWARD OPENING KIT	209

CATCHES	210
TWIN CATCH	210
GRISBI CATCH	211
RIVO CATCH	212
FLAT HANDLES	213
BRAVO FLAT HANDLE - EURO LINE	213
BRAVO FLAT HANDLE - PRIMA LINE	214
HANDLES	215
BRASS HANDLES	215
PANIC EXIT DEVICE AP001	216
AP001 LATERAL	217
AP001 TOP-BOTTOM	218
AP001 MODULAR	219
PUSH-BARS AP001	221
ADDITIONAL LOCKING MECHANISMS AP001	222
STRIKERS FOR HANDLES AP001	223
EXTERNAL CONTROLS	225
PANIC EXIT DEVICE AP002	226
AP002 LATERAL	227
AP002 TOP-BOTTOM	228
AP002 MODULAR	229
ADDITIONAL LOCKING MECHANISMS AP002	231
STRIKERS FOR HANDLES AP002	233
EXTERNAL CONTROLS	235
PANIC EXIT DEVICE AP100	236
PUSH-BARS AP100	237
AP100 MECHANISM	238
CENTRAL LOCKS FOR EMERGENCY EXITS	239
MULTIPOINT LOCKS FOR EMERGENCY EXITS	241
COUNTERPLATES FOR LOCKS AP100	242
PANIC EXIT DEVICE AP200	244
AP200 MECHANISM	245
CENTRAL LOCKS FOR EMERGENCY EXITS	246
MULTIPOINT LOCKS FOR EMERGENCY EXITS	247
COUNTERPLATES FOR LOCKS AP200	248
SEALING AND FASTENING MECHANISM COMPONENTS	
WINDOW BOLTS	252
SASH GIAP BOLTS	252
GIAP BOLT SECONDARY SASH KIT	254
TILT-AND-TURN WINDOW GIAP BOLTS	255
SUPERGIAP BOLTS	256
GIAP AND SUPERGIAP ACCESSORIES	257
ADJUSTABLE BOLTS	258
ADJUSTABLE BOLT SECONDARY SASH KIT	259
TWO-WAY BOLTS	260
PERIMETRAL CLOSING	262
PERIMETRAL FASTENING MECHANISM FOR FUTURA SECONDARY SASH	263
FUTURA CORNER BOLT	264
INCA BOLTS	265
TOTEM BOLTS	266
TOTEM MECHANISMS	268
SASH STOP	269
DOOR BOLTS	270
MAYA BOLTS	270
DOOR TOTEM BOLTS	271
PESOS BOLTS	273
BULL BOLTS	275
STELVIO BOLT	276
FLOOR STRIKER PLATES	277
CONNECTION RODS AND TERMINALS	279
FUTURA ADJUSTABLE TERMINALS	279
TOTEM TERMINALS	280
TERMINALS	281
CORNER DRIVES	282
CONNECTION RODS	283
STRIKERS AND FASTENING MECHANISMS	284
PAWLS	284
PAWLS 009	287
PAWLS FOR CURTAIN WALL	288

INDEX

CONNECTION JOINTS WITH PAWLS	289
ADDITIONAL FASTENING MECHANISM COMPONENTS	290
STRIKERS	291
DOOR STRIKERS	293
FLAT FRAME STRIKERS	294
BURGLAR-PROOF FASTENING MECHANISM	296
MICRO-VENTILATION	298
CHIC FASTENING ELEMENTS	299
BURGLAR BOLTS	300
BURGLAR BOLTS FOR CURTAIN WALL FLAT FRAME	301
FASTENING SYSTEM	302
KIT FOR TWO-WAY SASH CLOSING	302
KIT FOR ONE-WAY SASH CLOSING	304
MULTIPLE LOCK PIVOT KIT	305
CAP PLUGS COMPENSATORS CORNER JOINTS	
CORNER JOINTS	308
SNAP-MOUNTING CORNER JOINTS	308
KAMEL SNAP-MOUNTING CORNER JOINTS	309
KAMELDUE SNAP-MOUNTING CORNER JOINTS	310
KAPPA SNAP-MOUNTING CORNER JOINTS	311
REX SNAP-MOUNTING CORNER JOINTS	312
SCREW CORNER JOINTS	313
MULTIFUNCTION CORNER JOINT	314
ALIGNMENT CORNER JOINTS	315
T-JOINTS	316
ALEX STEEL T-JOINTS	316
ROBUR STEEL T-JOINTS	317
EXTRUDED ALUMINIUM T-JOINTS	318
ADAPTERS	320
VARIOUS COMPONENTS	326
CAPS	329
PLUGS AND SEALS	331
SASH SUPPORT PLUGS	331
CONDENSATE PLUGS	332
HOLE PLUGS	333
ARMS	
ARMS FOR CURTAIN WALL-TOP HUNG-SIDE HUNG WINDOWS	336
GS HD ARMS TYPE A	336
GS HD ARMS TYPE M	338
GS HD ARMS TYPE C	339
GS HD ARMS TYPE C PLUS	340
GS HD ARMS TYPE C PLUS SUPER	341
GS HD ARMS TYPE P	342
GS HD ARMS TYPE P SUPER	344
GS HD ARMS TYPE TS	345
PROJECTING ARMS WITH HINGE	347
SHIMS FOR PROJECTING ARMS	348
TOP HUNG ARMS ADJUSTMENT DEVICES	349
LASER ARMS	350
LIMITATION ARMS TYPE I	352
LIMITATION ARMS TYPE L	353
LIMITATION ARMS TYPE N	354
FRIZ ARMS FOR OUTWARD OPENING CASEMENT	355
PARALLEL ARMS	356
G-TYPE PARALLEL ARMS	357
PROJECTING CLOSING AND LIMITATION ARMS	360
ULK KIT	361
ULK KIT	363
ARMS FOR BOTTOM-HUNG WINDOWS AND LIMITERS	364
FRIZ ARMS	364
LIMITY ARMS	365
RALLENTY ARMS	366
LIMITATION ARMS WITH BLOCK	368

COMPLETE SYSTEMS FOR HANDLING AND CLOSING

2-STAR SKG - TILT-AND-TURN SYSTEMS	370
SKG - CREMONES	372
SKG - TILT-AND-TURN WINDOW KIT	373
2-STAR SKG - BURGLAR-PROOF FASTENING MECHANISM	374
SKG - ADDITIONAL ARM	375
SKG - CHIC 100 TILT-AND-TURN HINGES AND ARMS	376
SKG - CHIC 130 TILT-AND-TURN HINGES AND ARMS	377
SKG - FUTURA 3D 130 HINGES AND ARMS	378
2-STAR SKG - SIDE-HUNG SYSTEMS	379
SKG - CREMONES	381
SKG - SIDE-HUNG WINDOW KIT	382
2-STAR SKG - BURGLAR-PROOF FASTENING MECHANISM	383
SKG - CHIC 100 SIDE-HUNG HINGES AND ARMS	384
SKG - CHIC 130 SIDE-HUNG HINGES AND ARMS	385
SKG - FUTURA 3D 130 HINGES AND ARMS	386
3-STAR SKG - TILT-AND-TURN SYSTEMS	387
SKG - CREMONES	389
SKG - TILT-AND-TURN WINDOW KIT	390
3-STAR SKG BURGLAR-PROOF FASTENING MECHANISM	391
3-STAR SKG INCORRECT MOVEMENT SAFETY DEVICE	392
SKG - ADDITIONAL ARM	393
SKG - CHIC 100 TILT-AND-TURN HINGES AND ARMS	394
SKG - CHIC 130 TILT-AND-TURN HINGES AND ARMS	395
SKG - FUTURA 3D 130 HINGES AND ARMS	396
3-STAR SKG - SIDE-HUNG SYSTEMS	397
SKG - CREMONES	399
SKG - SIDE-HUNG WINDOW KIT	400
3-STAR SKG BURGLAR-PROOF FASTENING MECHANISM	401
3-STAR SKG INCORRECT MOVEMENT SAFETY DEVICE	402
SKG - CHIC 100 SIDE-HUNG HINGES AND ARMS	403
SKG - CHIC 130 SIDE-HUNG HINGES AND ARMS	404
SKG - FUTURA 3D 130 HINGES AND ARMS	405
SECURITY SASH	406
SECURITY SASH KIT	407
SECURITY SASH CREMONE	409
SECURITY SASH HINGES	410
SECURITY SASH ADDITIONAL FASTENING MECHANISMS CONFIGURATION EXAMPLES	411
HP BOTTOM-HUNG WINDOW	413
HP BOTTOM-HUNG WINDOW KIT	414
HP BOTTOM-HUNG WINDOW CREMONE	415
HP BOTTOM-HUNG WINDOW HINGES	416
HP ERRE BOTTOM-HUNG WINDOW HINGES	417
HP BOTTOM-HUNG WINDOW ADDITIONAL FASTENING MECHANISMS CONFIGURATION EXAMPLES	418
VENTILATION SASH	420
CONFIGURATION EXAMPLES	
VENTILATION SASH HINGES	421
VENTILATION SASH MECHANISMS	422
VENTILATION SASH FASTENING MECHANISMS	423
CHIC 100 SASH	424
CONFIGURATION EXAMPLES	
CHIC 100 SASH HINGES	425
CHIC 100 SASH MECHANISM	426
CHIC 100 SASH FASTENERS	427
CHIC 130 SASH	428
CONFIGURATION EXAMPLES	
CHIC 130 SASH HINGES	429
CHIC 130 SASH MECHANISM	430
CHIC 130 SASH FASTENERS	431
CHIC 130 ERRE SASH	432
CONFIGURATION EXAMPLES	
CHIC 130 ERRE SASH HINGES	433
CHIC 130 ERRE SASH MECHANISM	434
CHIC 130 ERRE SASH FASTENERS	435
GIESSE - BALCONY DOOR	436
CONFIGURATION EXAMPLES	
MOVEMENT M180 BACKSET 32 MM	437
LOCK FOR BALCONY DOOR	438
SUPRA 7 - DOUBLE WINDOW HANDLES	439
CHIC 100 TILT-AND-TURN HINGES AND ARMS	441
FUTURA 3D 130 HINGES AND ARMS	442

OS OPERATOR	443
UNICA OS OPERATOR CREMONE	444
OS OPERATOR MECHANISMS	445
EXTENSIONS	447
OS OPERATOR ARMS	448
CONFIGURATION EXAMPLES	
OS OPERATOR 2.0	450
UNICA OS OPERATOR CREMONE	452
OS OPERATOR 2.0 MECHANISM	453
OS OPERATOR 2 ARMS	454
OS OPERATOR 2.0 TOOLS	457
CONFIGURATION EXAMPLES	
JALOUSIE	459
UNICA CREMONE FOR JALOUSIE	460
JALOUSIE COMPONENTS	461
CONFIGURATION EXAMPLE	
PROVENCE	463
PROVENCE CREMONE	464
RODS	465
PROVENCE BOLT TIPS	466
PROVENCE STRIKERS	467
CONFIGURATION EXAMPLES	
MANUAL CONTROLS	469
CDM 30	469

MECHANISMS AND KITS FOR TILT-AND-TURN WINDOWS

CHIC 3D 100	472
CHIC 3D 100 HINGES AND ARMS	476
CHIC 3D 100 FASTENING MECHANISMS	477
CHIC 3D 100 ADDITIONAL FASTENING MECHANISMS AND HARDWARE	478
SECONDARY SASH HINGE SET FOR CHIC 3D 100	480
CONFIGURATION EXAMPLES	
FLUSH CHIC 3D 100	482
FLUSH CHIC 3D 100 HINGES AND ARMS	486
CHIC LIMITATION ARM	487
FLUSH CHIC 3D 100 FASTENING MECHANISM	488
FLUSH CHIC 3D 100 ADDITIONAL FASTENING MECHANISMS AND COMPONENTS	489
FLUSH CHIC 3D 100 SECONDARY SASH HINGE KIT	490
CONFIGURATION EXAMPLES	
CHIC 3D 130	492
CHIC 3D 130 HINGES AND ARMS	496
CHIC 3D 130 FASTENING MECHANISMS	497
CHIC 3D 130 ADDITIONAL FASTENING MECHANISMS AND HARDWARE	498
SECONDARY SASH HINGE SET FOR CHIC 3D 130	500
CONFIGURATION EXAMPLES	
CHIC 3D 150	502
CHIC 3D 150 HINGES AND ARMS	506
CHIC 3D 150 FASTENING MECHANISMS	508
CHIC 3D 150 ADDITIONAL FASTENING MECHANISMS AND ACCESSORIES	509
SECONDARY SASH HINGE SET FOR CHIC 3D 150	511
CONFIGURATION EXAMPLES	
CHIC 3D 130 ERRE	513
CHIC 3D 130 HINGES AND ARMS ERRE	517
CHIC 3D 130 FASTENING MECHANISMS R	518
CHIC 3D 130 ERRE ADDITIONAL FASTENING MECHANISMS AND HARDWARE	519
SECONDARY SASH HINGE SET FOR CHIC 3D 130 ERRE	521
CONFIGURATION EXAMPLES	
FUTURA 3D 130	523
FUTURA 3D 130 HINGES	527
FUTURA 3D 130 FASTENING MECHANISMS	528
FUTURA 3D 130 ARMS	529
FUTURA 3D 130 ADDITIONAL FASTENING MECHANISMS AND ACCESSORIES	531
FUTURA 3D 130 SECONDARY SASH	533
CONFIGURATION EXAMPLES	
FUTURA 3D 170 HP INVISIBLE	536
FUTURA 3D 170 HP INVISIBLE HINGES AND ARMS	540
FUTURA 3D 170 HP INVISIBLE FASTENING MECHANISMS	542
FUTURA 3D 170 HP INVISIBLE ADDITIONAL FASTENING MECHANISMS AND ACCESSORIES	543
FUTURA 3D 170 HP INVISIBLE SECONDARY SASH	545
CONFIGURATION EXAMPLES	

FUTURA 3D 80 FLUSH	547
FLUSH FUTURA 3D 80 HINGES	551
FUTURA 3D 80 FLUSH FASTENING MECHANISMS	552
FLUSH FUTURA 3D 80 ARMS	553
FUTURA 3D 80 ADDITIONAL FASTENING MECHANISMS AND ACCESSORIES	554
CONFIGURATION EXAMPLES	
FUTURA 3D A & F	557
FUTURA 3D A & F BASIC MECHANISM	560
FUTURA 3D A & F ADDITIONAL FASTENING MECHANISMS AND ACCESSORIES	561
CONFIGURATION EXAMPLES	
FUTURA 3D R	563
FUTURA 3D R HINGES	567
FUTURA 3D R FASTENING MECHANISMS	568
FUTURA 3D R ARMS	569
FUTURA 3D R ADDITIONAL FASTENING MECHANISMS AND ACCESSORIES	570
FUTURA 3D R SECONDARY SASH HINGE KIT	571
CONFIGURATION EXAMPLES	
CLASSIC 3D 80	573
CLASSIC 3D 80 HINGES	577
CLASSIC 3D 80 INDUSTRIAL HINGES	578
CLASSIC 3D 80 FASTENING MECHANISMS	579
CLASSIC 3D 80 INDUSTRIAL FASTENING MECHANISMS	580
CLASSIC 3D 80 ARMS	581
CLASSIC 3D 80 ADDITIONAL FASTENING MECHANISMS AND ACCESSORIES	582
CLASSIC 80 SECONDARY SASH	583
CONFIGURATION EXAMPLES	
GS990	586
GS990 BASIC MECHANISM	588
GS990 ARMS	589
GS990 ADDITIONAL FASTENING MECHANISMS AND ACCESSORIES	590
CONFIGURATION EXAMPLES	

ACCESSORIES AND FASTENING MECHANISMS FOR SLIDERS

ADJUSTABLE PULLEYS	594
ADJUSTABLE CARRERA 1 PULLEYS	594
ADJUSTABLE CARRERA 2 PULLEYS	596
ADJUSTABLE PULLEYS 1 WHEEL	598
ADJUSTABLE PULLEYS 2 WHEELS	599
ADJUSTABLE PULLEYS 4 WHEELS	600
FIXED PULLEYS	601
FIXED CARRERA 1 PULLEYS	601
FIXED CARRERA 2 PULLEYS	603
FIXED PULLEYS 1 WHEEL	604
FIXED PULLEYS 2 WHEELS	605
RECESSED HANDLES	606
BRIO EVO HANDLE	606
BRIO EVO KEY HANDLE	608
BRIO KEY DRIVE HANDLE WITH BRIO EVO	610
BRIO KEY RECESSED HANDLE WITH BRIO EVO	612
BRIO MINI EVO HANDLE	614
BRIO EVO L HANDLE	616
BRIO EVO XL HANDLE	618
ROUNDED BRIO RAPID EVO HANDLE	620
BLIND BRIO EVO HANDLE	621
NADA HANDLE	622
PRATIKA HANDLE	623
PRATIKA DUO HANDLE	624
PRATIKA DUO KEY HANDLE	625
EXTERNAL PULL HANDLES	626
BRIO PULL HANDLES	626
BRIO KEY DRIVE ROD	628
BRIO EVO RECESSED HANDLES	629
RECESSED HANDLES	631
INTERNAL PULL HANDLES	632
BRIO EVO SIDE DRIVE HANDLE	632
PRATIKA SIDE PULL HANDLE	634
SLIDING SYSTEM CREMONES	635
CITY CREMONES	635
CITY KEY CREMONE	636

FASTENING MECHANISM COMPONENTS	638
BRIO EVO BIG NIBS.....	638
BRIO SMALL NIBS.....	639
BRIO ZAMAK NIBS.....	641
PRATIKA/NADA NIBS.....	642
INSERTED COUNTERPLATES.....	643
FRONT-MOUNTED COUNTERPLATES.....	644
COUNTERPLATES FOR MILLED RAIL.....	645
VARIOUS COUNTERPLATES.....	646
BRIO EVO COUPLING KIT.....	647
BRIO COUPLING KIT.....	649
PRATIKA/NADA COUPLING KIT.....	650
DELTA PLUS LUG HANDLE.....	652
FRONT APPLICATION HANDLES	654
BUTTERFLY HANDLE.....	654
MULTILOCKS	655
MISMO.....	655
BRIO TOP SECURITY.....	656
CHAMPION PLUS MULTILOCK	658
CHAMPION PLUS FASTENING RODS WITH MICRO-VENTILATION.....	659
CHAMPION PLUS FIXING KIT WITH MICRO-VENTILATION.....	661
CHAMPION PLUS CLOSING RODS.....	665
CHAMPION PLUS FIXING KIT.....	667
CHAMPION PLUS CLOSING RODS 90.....	671
INCORRECT MOVEMENT SAFETY DEVICE.....	673
PRIMA CHAMPION PLUS WINDOW HANDLE.....	674
RECESSED WINDOW HANDLE.....	675
EXTERNAL RECESS PULL HANDLE.....	676
BLIND INTERNAL RECESS PULL HANDLE.....	677
SYSTEM SLIDER KIT	678
2-SASH WINDOW ASSEMBLY KIT.....	678
DAMPER PLUGS	679
SASH STOP DEVICE.....	682
MACHINING AND DUST COVERS	683
VARIOUS SLIDING COMPONENTS	704
BUSHES.....	704
CYLINDERS AND KEYS.....	705
NYLON PARTS.....	706

Treatments and finishes

Base/Neutral

Neutral finish (code 000) means all products without a finish that cannot be subsequently painted/oxidized.

Base finishes (codes 005-006) are surface treatments that Giesse applies to products that will subsequently be painted or anodised. Base Painting (code 005) is a passivation treatment free from Chromium VI which permits retaining the surface characteristics suited for subsequent painting.

Base Painting is ideal for both powder and liquid painting. It is compatible with all pre-treatments that include an acid-etching cleaning phase.

Base Oxidation (code 006) is instead a barrelling treatment suitable for subsequent anodic oxidation.

Resins

Plastic polymers are all the products made of polyamide.

Anodised Elox

Anodised/Elox means all the products with an oxidized and/or electro-colour finish.

Oxidation is achievable solely on products made of extruded aluminium.

Painted

Painted means all the products that are painted in the in-house painting system, using only thermosetting powder paints that are non-toxic and harmless, therefore non-polluting and environmentally friendly (free of TGIC).

Trend/Gold/Brass

This group of finishes comprises Trend (prestige finishes for modern, stylish casements), gold oxidized, liquid painted or brass products.

Oxidation is achievable solely on products made of extruded aluminium.

BASE/NEUTRAL	ANODISED/ELOX	PAINTED	TREND/GOLD/BRASS
000 raw/stainless steel/nylon 005 base primer 006 base oxidation 010 black nylon 501 matt black	020 silver 060 bronze 190 elettrogiesse 9	362 F1 Silver 376 Giesse silver 380 euro bronze 382 Giesse dark bronze 385 bronze Giesse 390 Euro Electro 5 410 pure white 9010 411 ~ Ral 9010 white, 25% Gloss 414 ~ Ral 1015 clear ivory 415 ~ Ral 9003 bright white 420 ~ Ral 9001 cream white 430 ~ Ral 1013 pearl white 443 glossy gray ~ Ral 7016 461 ~ Ral 3000 red 470 ~ Ral 9016 white 480 ~ Ral 6005 musk green 490 ~ Ral 8017 chocolate brown 500 ~ Ral 9005 black 510 mat green SFX 530 mat gray SFX 610 French white 9010 611 ~ Ral 9010 white 640 ~ Ral 8019 mat brown 641 ~ Ral 8019 mat brown 650 moss brown Grinz 660 moss green Grinz 670 mat brown SFX 680 ~ Ral 9002 white 700 ~ Ral 6029 Giesse Green 790 nickel white 960 ~ Ral 1247 dark brown 970 ~ Ral 9006 silver	040 gold 310 trend gold 325 trend nichelsat 350 trend cromosat 375 antique silver 383 antique bronze
PLASTIC POLYMERS			
542 pale grey 544 grey 560 white 590 black 591 black Ral 9005 - RE30			

SIDE-HUNG TYPE PROFILE CROSS-SECTIONS C

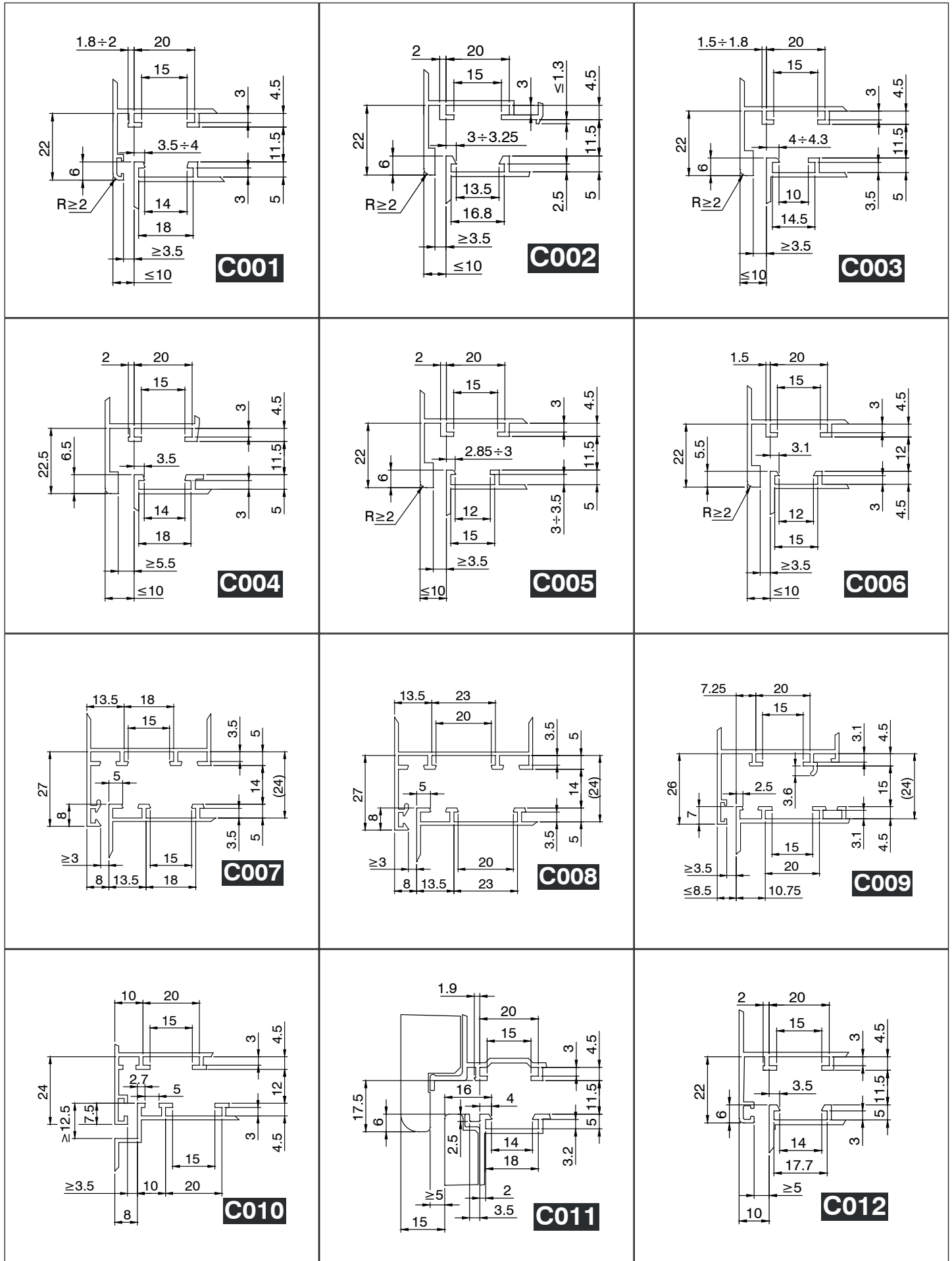

SIDE-HUNG TYPE PROFILE CROSS-SECTIONS C

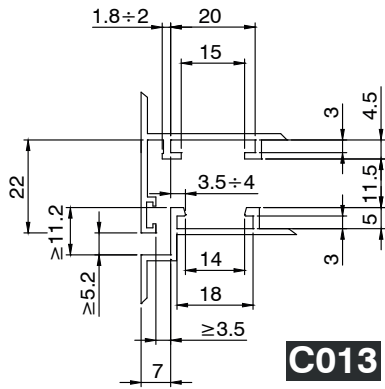

C013

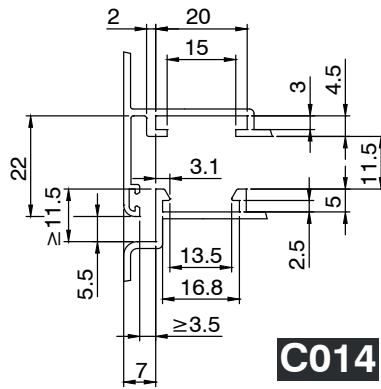

C014

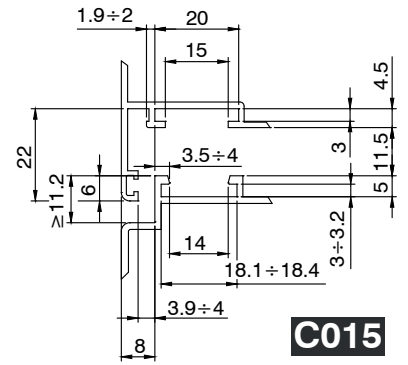

C015

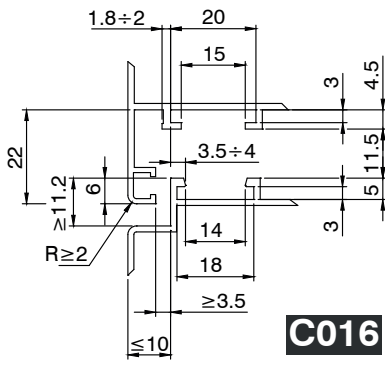

C016

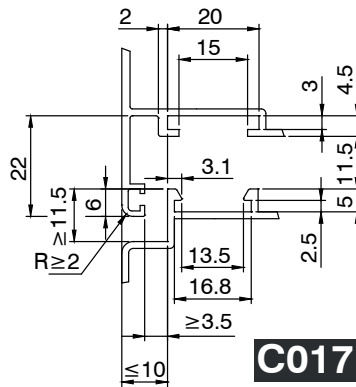

C017



For an exact series/code match, see the on-line catalogue.

SIDE-HUNG TYPE PROFILE CROSS-SECTIONS C - COMPANIES - SERIES/SYSTEMS

C001

A.SER - MODENA
A.SER - CLASSICA
ABYAT - C100
ADOPEN - AD 55
ADOPEN - AD 55T
AKFA GROUP - AKI65
ALCAR - AE0943
ALCAS - AW 50
ALCEMAR - MONACO
ALDOM - TB65LT
ALEXIA - 54-72 HT
ALEXIA - 65 ATLAS
ALEXIA - 74 ELEGANCE
ALEXIA - 74 MAGNUM
ALEXIA - 65 ATLAS
ALEXIA - 74 MAGNUM
ELEGANCE
ALEXIA - 65 ATLAS PORTE
ALEXIA - 74 MAGNUM PORTE
ALLCO - EXPORT 50
ALLCO - EXPORT 50TT
ALLCO - EXPORT 45
ALLCO - K40 SORMONTO
ALLCO - ALLCO.TEC 72
ALLCO - ALLCO.TEC 72
MINIMAL
ALLCO - EXPORT 56TT
ALLCO - ALLCO HT 80
ALLCO - WS 75 FL
ALPROF - T72
ALSISTEM - PLANET 62 TT
ALSISTEM - PLANET 50 TT
ALSISTEM - PLANET 72 HT
ALSISTEM - PLANET 45
ALSISTEM - PLANET 72 PLUS
ALSISTEM - PLANET 62 PLUS
ALSISTEM - PLANET 50 PLUS
ALSISTEM - ECOSLIM 50 TT
ALSISTEM - ECOSLIM 62 TT
ALSISTEM - ECOSLIM 62 UP
ALSISTEM - PLANET 62 UP
ALSISTEM - PLANET NEO 62 UP
ALSISTEM - PLANET NEO 72 PLUS
ALSISTEM - PLANET 72 TT UP
ALUAR - ALTEZZA
ALUBIN - AD 45
ALUCANSA - AL 67 RPT
ALUGOM - ALG 55 ESTANDAR
ALUGOM - ALG 65 OPTIMA
ALUGOM - ALG 65 OPTIMA HS
ALUGOM - ALG 75 MAXIMA HS
ALUGOM - ALG 75 MAXIMA
ALUK - VENTA
ALUK - TRITON
ALUMAFEL - UNNO
ALUMAFEL - UNNO-THERMIC
ALUMARTE - 34000 RT
ALUMEC - SYNTHESIS-57
ALUMEC - SYNTHESIS 45
ALUMEC - SYNTHESIS 52
ALUMIL - M9400
ALUMIL - M11500
ALUMIL - S60
ALUMIL - S77
ALUMIL - M15000
ALUMIL - M9660
ALUMIL - S67
ALUMIL - M940
ALUMIL - M9650
ALUMIL - M20650
ALUMINCO - W 450
ALUMINCO - W 540
ALUMINCO - W 4750
ALUMINCO - W 4900
ALUPROF - MB-70 HI
ALUPROF - MB-104
ASISTAL ALUMINIUM - TH 55
BALEXCO - BL45
BURAK ALLUMINIUM - BM 72
CAPPELLO GROUP SPA - EK79TH
CAPPELLO GROUP SPA - EK53TH
CAPPELLO GROUP SPA - EK58TH

CAPPELLO GROUP SPA - EK61TH
CAPPELLO GROUP SPA - EK68TH
CAPPELLO GROUP SPA - EK69TH
CAPPELLO GROUP SPA - EK80TH
CAPPELLO GROUP SPA - EK95TH
CENTRO ALUM - RENOVA
OCULTEC
CLL - TECNO CE 65 TT
CLL - TECNO CE 85 TT
CORTIZO - COR 70 IND
CORTIZO - COR 3500
CORTIZO - COR 60 HO
CORTIZO - COR 70 HO
CORTIZO - COR 70
CORTIZO - COR 2000
CUHADAROGLU - ST 70
CUHADAROGLU - ST 80
CUHADAROGLU - DE 60
DFV - SINERGY - LINEA 65 CE
DFV - SINERGY - LINEA 75 CE
DFV - SINERGY - SINERGY LINEA
DFV - SINERGY - ECOWIN TH72
DOMAL HYDRO BUILDING SYSTEM IT - STOPPER PG
DOMAL HYDRO BUILDING SYSTEM IT - DOMALBRIGHT PA70S
DOMAL HYDRO BUILDING SYSTEM IT - DOMAL EXTRATHERMIC 62
DOMAL HYDRO BUILDING SYSTEM IT - TOP TB 65
DOMAL HYDRO BUILDING SYSTEM IT - PERFORMANCE 70
DOMAL HYDRO BUILDING SYSTEM IT - TOP TB 75
DOMAL HYDRO BUILDING SYSTEM IT - AVANTIS 70
DOMAL HYDRO BUILDING SYSTEM IT - TOP TB65
MINIMALE
ENDER ALUMINIUM - EIN 55
ENDER ALUMINIUM - EIN 64
ENDER ALUMINIUM - EIN 74
ETA - START 470 TT
ETA - START 560 TT
ETA - START 410
ETA - START 640 TT
ETA - START 510
ETEM - E 45
ETEM - E 75
ETNALL - ET 45
EVEREST - 70000
EXTRUGAL - P45
EXTRUGASA - V-8000-50 RPT
EXTRUGASA - V-8000-58 RPT
FEAL - TERMO 85
FEAL - TERMO 65
FEAL - TERMO 65 PLUS
GASTALDELLO - EL65LL-PAS
GASTALDELLO - EL 76 LL
GASTALDELLO - EUROLINE 50N
GASTALDELLO - EUROLINE 65LL
GASTALDELLO - EUROLINE EL 90 IT
GEAL - HP 600
GEAL - HP 700
GEAL - HP SYSTEM SLIM
GEAL - HP 600 ANTA STYLE
GEAL - HP 820
GENERICO - ELIOS 50C - CASEMENT
GENERICO - ELIOS 50C - BALCONY

GENERICO - ELIOS 50C - DOOR
GIESSE - MASTER C001
GOS-C - GOS-C T70 PACK 4
GOS-C - GOS-C T66 HS
GOS-C - GOS-C T70 HS
GULF EXTRUSION - TB-600 SERIES
HEROAL - W 77
HILAL ALUMINIUM - H 55
HYDRO-SAPA ARGENTINA - HA 62 RPT
INDINVEST - GOLD 400
INDINVEST - GOLD 500
INDINVEST - GOLD 600
INDINVEST - GOLD 450TT
INDINVEST - GOLD 450
INDINVEST - DOGMA
INDINVEST - DOGMA LIGHT
INDINVEST - DOGMA SLIM
INDINVEST - DOGMA PRO
INDINVEST - GOLD 502
INESPAL - A54 RPT
INSTALLUX - ECLIPSE 70TH OC
ITESAL - IT-45 RPT
ITESAL - IT-61 RPT
ITESAL - IT-75 RPT
KAWNEER - ALCOA BRASIL - NG7
KRISTALL - KEEPER 61/68
KURTOGLU - 70 TH
KURTOGLU - 84 TH
MERIDIONALE ALLUMINIO - MA 72 HP
MEXALL - MX70
MUSKITA ALUMINIUM - MU 2075
MV ABITHAL - ABITHAL-GREEN
NAPCO - N 45
ORIGINAL SYSTEM HYDRO BUILDING - R 72CE
PONZIO - WS 45
PONZIO - WS 45 TT
PONZIO - WS 55 TT
PONZIO - WS 75 AS
PONZIO - WS 65 TH
PONZIO - WS 75 TH
PROFILATI - EKU 53
PROFILATI - EKU 64TT
PROFILATI - EKU 72TT
PROFILATI - EKU 53TT
PROFILATI - EKU 40
PROFILATI - EKU 66TT
PROFILATI - EKU 78TT
PROFILATI - EKU PERFEKTION
PROFILATI - EKU 52TT
PROFILATI - EKU PERFEKTION HPS
PROFILATI - EKU 66TT HPS
Q SYSTEM - Q57
QALEX - POLAR 47
QALEX - PANDA 47
QALEX - T-PANDA 47
RESCARA INTERNATIONAL - RWT 64
RESCARA INTERNATIONAL - RWT 75
SYSTEM ALUMINIUM - W55
SERIES W1
TECHNAL - UNNO THERMIC
TECNO FURNITURE - PR50
TECNO FURNITURE - PR50 TT
TECNO FURNITURE - PR65 TT
TECNO FURNITURE - PR75 TT
TGP SISTEMI - TGP 45
TGP SISTEMI - TGP TH 52
TGP SISTEMI - TGP TH 60
TGP SISTEMI - TGP TH 68
THERMECO - EC65TB
TOMA - ATLANTIS 45
TOMA - ATLANTIS 68TT
TOMA - ATLANTIS 55TT
TOMA - ATLANTIS 80TT
TOMA - TIERRE 590 TH
TOMA - TIERRE 640TH
TOMA - NGS MINIMAL
TOMA - TIERRE 600TH
TP PROFILATI - EKOS - 50 TH
TP PROFILATI - EKOS - 85 TH

TP PROFILATI - EKOS - 75 TH
TPR - TW74
TWIN SYSTEMS - CX 600
TWIN SYSTEMS - CX 700
TWIN SYSTEMS - CX 650
TWIN SYSTEMS - CX 700 ASE
TWIN SYSTEMS - MX 603
TWIN SYSTEMS - CX 700 AS
TWIN SYSTEMS - CX 700 HP
TWIN SYSTEMS - CX 850 PH
TWIN SYSTEMS - MX 753
ULUSAN - AWT 64
ULUSAN - AWT 58
ULUSAN - AW 50

C002

GIESSE - MASTER C002
GIUGNI - GIUGNI TT
METRA - NC 50I
METRA - NC 55I
METRA - NC 65 STH
METRA - NC 72 STH
METRA - NC 50 STH
METRA - NC 65 STH HES
METRA - NC 75 STH HES-WS

C003

ALUK - REVA 54
GUTMANN - S70
HEROAL - 110 ES
HEROAL - W 72
HEROAL - W 65
HEROAL - W 50
INSTALLUX - ESPACE 50TH
INSTALLUX - ESPACE 50
INSTALLUX - ESPACE 40
RESCARA INTERNATIONAL - P69
REYNAERS - XS50
REYNAERS - CS 45 PA
REYNAERS - XS68

C004

INDINVEST - PLATHINA 69
INDINVEST - PLATHINA 75

C005

ALUMAFEL - FORMA-THERMIC
ALUMAFEL - FORMA

C006

GULF EXTRUSION - 45-E
TECHNAL - FC

C007

CLL - TECNO 45
CLL - TECNO 50 TT
CLL - TECNO 60-68 TT
CLL - TECNO 76 TT
COLMA - MAR3HTI
ETA - ER 750 TT
ETA - ER 670
ETA - ER 730
ETNALL - TT 50
GASTALDELLO - NT 50
GASTALDELLO - NT 52
GASTALDELLO - NT 60
GASTALDELLO - NT 68
GASTALDELLO - NT 65 TT
GASTALDELLO - NT 65
ORIGINAL SYSTEM HYDRO BUILDING - R 40
ORIGINAL SYSTEM HYDRO BUILDING - R 62TT
ORIGINAL SYSTEM HYDRO BUILDING - R 72TT
ORIGINAL SYSTEM HYDRO BUILDING - R 50TT (NEW)
ORIGINAL SYSTEM HYDRO BUILDING - R 85TT
ORIGINAL SYSTEM HYDRO BUILDING - R 72TT 1.3 HP
ORIGINAL SYSTEM HYDRO BUILDING - R 85TT 1.0
PONZIO - NT 50
PONZIO - NT 52
PONZIO - NT 60
PONZIO - NT 68

PONZIO - NEWTEC 50
PERSIANE
PONZIO - NT 65 TT
PONZIO - NT 75 TT HI
TECNO FURNITURE - PR66 TT
TECNO FURNITURE - PR58
TECNO FURNITURE - TF 75 TT
TOMA - RS 67TT
TWIN SYSTEMS - RX 600
TWIN SYSTEMS - RX 700
TWIN SYSTEMS - RX 450
TWIN SYSTEMS - RX 700 HP
TWIN SYSTEMS - RX 700 HP +

C008

ORIGINAL SYSTEM HYDRO BUILDING - R 50
ORIGINAL SYSTEM HYDRO BUILDING - R 60TT

C009

ALLCO - ALLCO5S
ALLCO - ALLCO5STT
ALLCO - NEW-AGE

C010

ETNALL - ET 40
ETNALL - ET 43
METRA - NUOVO NC40S
MV ABITHAL - ABITHAL POINT
PROFILATI - PE 40 SISTEMA1
PROFILATI - PE 50 SISTEMA1
PROFILATI - PE 58TT
SORMONTO

C011

PROFILATI - THERMOLEGNO

C012

DOMAL HYDRO BUILDING SYSTEM IT - AVANTIS 55

C013

ALUAR - A30NEW-PORTE
DOMAL HYDRO BUILDING SYSTEM IT - STOPPER PG
DOMAL HYDRO BUILDING SYSTEM IT - DOMALBRIGHT PA70S
DOMAL HYDRO BUILDING SYSTEM IT - DOMAL EXTRATHERMIC 62
ETNALL - ET 45

C015

INDINVEST - GOLD 400
INDINVEST - GOLD 500
INDINVEST - GOLD 450TT
INDINVEST - GOLD 450
PROFILATI - EKU 53TT
PROFILATI - EKU 60TT
PROFILATI - EKU 80TT
TOMA - ATLANTIS 68TT
TOMA - ATLANTIS 45
COMPLANARE
TOMA - ATLANTIS 55TT

C016

ALLCO - EXPORT 51TT
DOMAL HYDRO BUILDING SYSTEM IT - TOP TB 65
ETA - START 470 TT
ETA - START 410
ETA - START 510

C017

METRA - NC 50I
METRA - NC 65 STH
METRA - NC 72 STH
METRA - NC 50 STH

PIVOTING WINDOW TYPE PROFILE CROSS-SECTIONS P

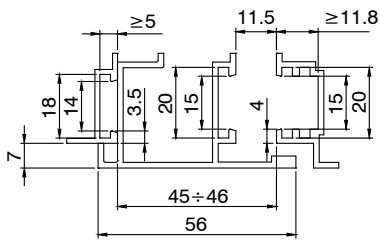

P001

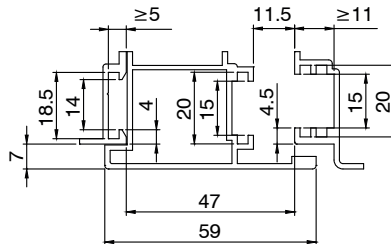

P002

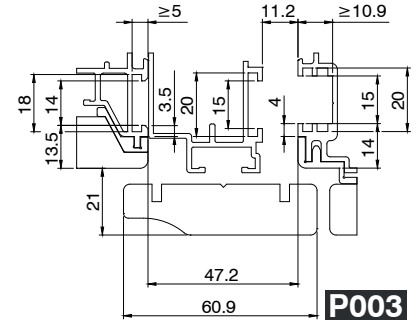

P003

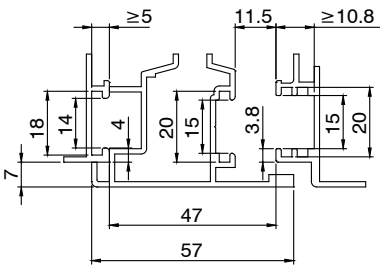

P004

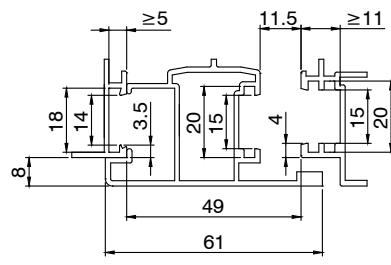

P005

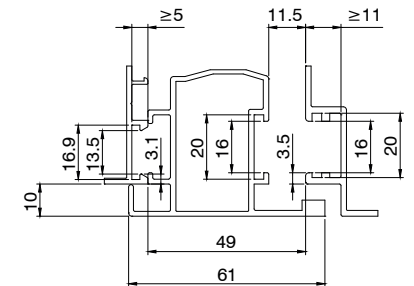

P006

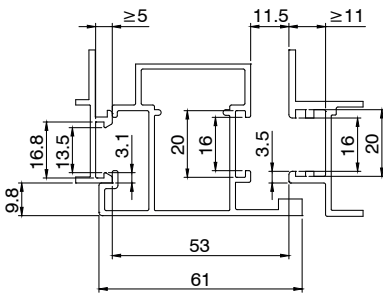

P007

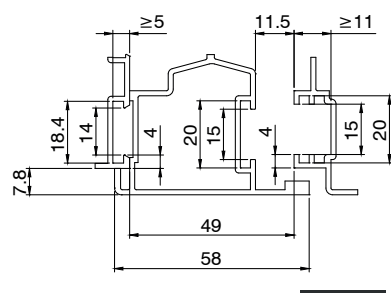

P008

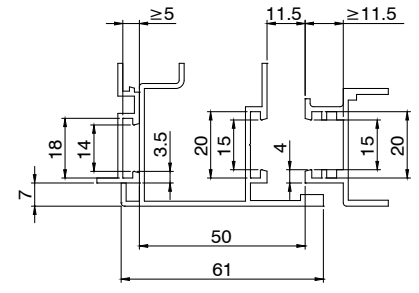

P009

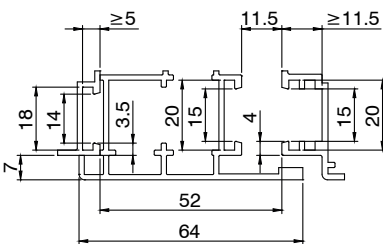

P010



For an exact series/code match, see the on-line catalogue.

PIVOTING WINDOW TYPE PROFILE CROSS-SECTIONS P - COMPANIES - SERIES/SYSTEMS

P001

DOMAL HYDRO BUILDING SYSTEM IT - STOPPER PG
DOMAL HYDRO BUILDING SYSTEM IT - DOMALBREAKPA52
DOMAL HYDRO BUILDING SYSTEM IT - DOMAL EXTRATHERMIC 62

P002

ALLCO - EXPORT 50
ALLCO - EXPORT 50TT
ALLCO - EXPORT 45
MERIDIONALE ALLUMINIO - MA 72 HP
PONZIO - WS 55 TT

P004

MV ABITHAL - ABITHAL-GREEN
MV ABITHAL - EURO KEEPER 45

P005

INDINVEST - GOLD 400
INDINVEST - GOLD 500
INDINVEST - GOLD 600
INDINVEST - GOLD 450TT
INDINVEST - GOLD 450
INDINVEST - GOLD 502 HC
TOMA - TIERRE 550 TH

P006

ALUMIL - M11500
METRA - NC 50I
METRA - NC 50 STH

P007

METRA - NC 65 STH

P008

PROFILATI - EKU 53
PROFILATI - EKU 64TT
PROFILATI - EKU 53TT
PROFILATI - EKU WOOD 72TT

P009

ALEXIA - 74 MAGNUM
ALEXIA - 65 ATLAS
DOMAL HYDRO BUILDING SYSTEM IT - DOMALBREAKPA63
DOMAL HYDRO BUILDING SYSTEM IT - DOMALBREAKPA70S

P010

DOMAL HYDRO BUILDING SYSTEM IT - DOMALBRIGHT PA70S

Code	Pag	SIDE-HUNG CROSS-SECTIONS TYPE															PIVOTING CROSS-SECTIONS TYPE											
		C001	C002	C003	C004	C005	C006	C007	C008	C009	C010	C011	C012	C013	C014	C015	C016	C017	P001	P002	P003	P004	P005	P006	P007	P008	P009	P010
00094U	3																											
00095U	3																											
00099U	3				■																							
00100U	3																											
00103U	5																											
00112N	33	■	■	■									■	■					■	■								
00115U	5	■	■										■		■	■			■	■					■	■	■	
00119	5	■	■	■									■	■	■	■	■		■	■		■	■		■	■		
001201	3	■	■										■		■	■			■	■					■	■	■	
001202	3	■	■										■		■	■			■						■	■	■	
00120U	3	■	■										■		■	■			■	■					■	■	■	
00120U	410	■	■										■		■	■			■	■					■	■	■	
001211	3	■	■										■			■			■	■						■		
001212	3	■	■										■			■			■	■						■		
00121U	3	■	■										■			■			■	■						■		
001221	3			■										■									■	■				
001222	3			■										■									■	■				
00122U	3			■										■									■	■				
001231	3			■										■														
001232	3			■										■														
00123U	3			■										■														
00126U	3									■																		
00127U	3									■																		
001281	3								■																			
001282	3								■																			
00128U	3								■																			
00128U	410								■																			
00129U	3								■																			
00130U	3																											
001341	3																											
001342	3																											
00134U	3																											
00135U	3																											
00136U	3				■																							
00137U	3																											
00142U	3																											
001431	3	■	■											■		■	■			■					■			
001432	3	■	■											■		■	■			■					■			
00143U	3	■	■											■		■	■			■					■			
0014411	3	■	■	■										■	■	■	■	■		■	■			■	■			
0014421	3	■	■	■										■	■	■	■	■		■	■			■	■			
00144N	3	■	■	■										■	■	■	■	■		■	■			■	■			
00147N	3																											
00149U	7	■	■																									
00150U	7	■	■											■		■	■			■	■	■			■	■		
00151U	7	■	■											■					■	■						■		
00157U	7									■																		
00171	5																											
00227U	3																											
00240U	3																											
00258U	3																											
002591	3																											
002592	3																											
00259U	3																											
002701	3																											
002702	3																											
00278U	3																											
00279U	3																											

CODE / PROFILE CROSS-SECTIONS TYPE

Code	Pag	SIDE-HUNG CROSS-SECTIONS TYPE															PIVOTING CROSS-SECTIONS TYPE											
		C001	C002	C003	C004	C005	C006	C007	C008	C009	C010	C011	C012	C013	C014	C015	C016	C017	P001	P002	P003	P004	P005	P006	P007	P008	P009	P010
002811	3																											
002812	3																											
00281U	3																											
002851	4																											
002852	4																											
00285U	4																											
00305	308			■										■														
00313	308	■	■										■		■			■								■		
00321010	311			■										■														
00322010	311																											
00323010	311			■					■									■										
00325	312																											
00326	312																											
00330	310	■	■								■																	
00332	309																											
00334	312																											
00335	310																											
00336	309								■	■																		
00337	309								■	■																		
00338	309								■																			
00339	309								■																			
00340	309	■	■																									
00344	309	■	■											■		■												■
00349	309	■	■							■																		
00350	312	■	■						■																			
00351X	312	■	■																									
00352	312																											
00353	312																											
00355	312																											
00356	312	■	■																									
00357	309	■	■											■														
00360	315	■	■																									
00362	315																											
00363	315																											
00365	315	■	■																									
00366	315	■	■																									
00367	308	■	■																									
00397	313	■	■																									
00398	313																											
00420	319																											
00425	319	■	■																									
00428N	319	■	■																									
00429	319	■	■																									
00430N	319																											
00431	319	■	■																									
00432	319	■	■																									
00443	319	■	■																									
00471	316			■											■													
00474	319								■																			
00475N	319								■																			
00476	317								■																			
00477	317									■																		
00479	319									■																		
00481	317																											
00484	319																											
00485	319										■																	
00486	319									■																		
00487	319										■																	

Code	Pag	SIDE-HUNG CROSS-SECTIONS TYPE															PIVOTING CROSS-SECTIONS TYPE											
		C001	C002	C003	C004	C005	C006	C007	C008	C009	C010	C011	C012	C013	C014	C015	C016	C017	P001	P002	P003	P004	P005	P006	P007	P008	P009	P010
005271	4	■	■				■																					
005272	4	■	■				■																					
00527U	4	■	■				■																					
00529U	4	■	■				■						■						■	■								
00561	29	■	■	■									■	■	■	■	■	■	■	■		■	■	■	■	■	■	■
005641	4								■	■																		
005642	4								■	■																		
00564U	4								■	■																		
00591	29	■	■	■									■	■	■	■	■	■	■	■	■	■	■	■	■	■	■	■
00598N	29	■	■										■		■	■						■	■		■			
00598N	410	■	■										■		■	■						■	■		■			
00599	29	■	■	■									■	■	■	■	■	■	■	■	■	■	■	■	■	■	■	■
00599	410	■	■	■									■	■	■	■	■	■	■	■	■	■	■	■	■	■	■	■
00600N	25	■	■	■									■	■	■	■	■	■	■	■	■	■	■	■	■	■	■	■
00600N	410	■	■	■									■	■	■	■	■	■	■	■	■	■	■	■	■	■	■	■
00600N	416	■	■	■									■	■	■	■	■	■	■	■	■	■	■	■	■	■	■	■
00601N	25	■	■										■														■	
00602N	25								■																			
00602N	410								■																			
00602N	417								■																			
00603N	25								■																			
00604N	25									■																		
00605N	25									■																		
00606N	25										■																	
00607N	25	■	■												■								■			■		
00609N	25				■		■																					
00612U	4							■																				
00681	26	■	■	■			■						■	■	■	■	■	■	■	■	■	■	■	■	■	■	■	■
00681	410	■	■	■			■						■	■	■	■	■	■	■	■	■	■	■	■	■	■	■	■
00682	26								■																			
00682	410								■																			
00684	26	■	■	■									■		■								■		■	■	■	■
00685	26	■	■										■			■										■	■	■
00687	26									■																		
00688	26										■																	
00689	26																											
00690	26																											
00700	27	■	■										■		■	■						■	■	■		■	■	■
00700	410	■	■										■		■	■						■	■	■		■	■	■
00701	27								■																			
00701	410								■																			
00702	27																											
00703	27	■	■										■		■	■						■				■	■	■
00725	61	■	■					■							■	■												
00726	62								■																			
00755	59																											
00756	60																											
00757	58																											
00763	58																											
0078902	648																											
00801	597																											
0080201	648																											
00806	595																											
0083101	620																											
00859	598																											
0086401	328																											
0087302	619																											
00878	619																											

CODE / PROFILE CROSS-SECTIONS TYPE

Code	Pag	SIDE-HUNG CROSS-SECTIONS TYPE															PIVOTING CROSS-SECTIONS TYPE											
		C001	C002	C003	C004	C005	C006	C007	C008	C009	C010	C011	C012	C013	C014	C015	C016	C017	P001	P002	P003	P004	P005	P006	P007	P008	P009	P010
00889N	360																											
00890N	360																											
00917	58																											
00920	58																											
00925N	31	■	■																									
00926N	31																											
00927N	31																											
00929N	31																											
00930	31																											
00934	157																											
00935	157																											
00936	157																											
00937	157																											
00938	157																											
00939	290																											
00940	32	■	■																									
00943	157																											
00945	437																											
00946	438																											
00947	437	■	■	■		■	■						■	■	■		■											
00947	477	■	■	■		■	■						■	■	■		■											
00947	488	■	■	■		■	■						■	■	■		■											
00947	497	■	■	■		■	■						■	■	■		■											
00947	508	■	■	■		■	■						■	■	■		■											
00947	528	■	■	■		■	■						■	■	■		■											
00947	542	■	■	■		■	■						■	■	■		■											
00947	552	■	■	■		■	■						■	■	■		■											
00948	153	■	■	■	■	■	■					■	■	■	■	■	■											
00949	155	■	■	■	■	■	■	■				■	■	■	■	■	■	■	■	■	■	■	■	■	■	■	■	■
00949	422	■	■	■	■	■	■	■				■	■	■	■	■	■	■	■	■	■	■	■	■	■	■	■	■
00949	426	■	■	■	■	■	■	■				■	■	■	■	■	■	■	■	■	■	■	■	■	■	■	■	■
00949	430	■	■	■	■	■	■	■				■	■	■	■	■	■	■	■	■	■	■	■	■	■	■	■	■
00949	580	■	■	■	■	■	■	■				■	■	■	■	■	■	■	■	■	■	■	■	■	■	■	■	■
00957	82																											
00958	84																											
00959	82																											
00959	415																											
00960	84	■	■	■	■		■	■					■	■	■	■	■	■	■	■	■	■	■	■	■	■	■	■
00960	372	■	■	■	■		■	■					■	■	■	■	■	■	■	■	■	■	■	■	■	■	■	■
00960	381	■	■	■	■		■	■					■	■	■	■	■	■	■	■	■	■	■	■	■	■	■	■
00960	389	■	■	■	■		■	■					■	■	■	■	■	■	■	■	■	■	■	■	■	■	■	■
00960	399	■	■	■	■		■	■					■	■	■	■	■	■	■	■	■	■	■	■	■	■	■	■
00961	84																											
00961	409																											
00962	84																											
00963	204																											
00964	85																											
00965	85																											
00966	204																											
00967	86																											
00968	88																											
009691	87																											
00986	155																											
009881	149																											
009882	149																											
00989	148																											
00989	149																											
00990	148																											

CODE / PROFILE CROSS-SECTIONS TYPE

Code	Pag	SIDE-HUNG CROSS-SECTIONS TYPE															PIVOTING CROSS-SECTIONS TYPE											
		C001	C002	C003	C004	C005	C006	C007	C008	C009	C010	C011	C012	C013	C014	C015	C016	C017	P001	P002	P003	P004	P005	P006	P007	P008	P009	P010
01086	409	■	■	■	■														■				■					
01087	111	■	■																									
01091K	98	■	■	■	■	■	■	■	■	■		■	■	■	■	■	■		■	■		■	■	■	■	■	■	■
01092K	94	■	■	■	■	■	■	■	■	■		■	■	■	■	■	■		■	■		■	■	■	■	■	■	■
01094	92	■	■	■	■	■	■					■	■	■	■	■	■		■	■		■	■	■	■	■	■	■
01094	415	■	■	■	■	■	■					■	■	■	■	■	■		■	■		■	■	■	■	■	■	■
01108	92	■	■	■	■	■	■	■	■	■		■	■	■	■	■	■		■	■		■	■	■	■	■	■	■
01109	92	■	■	■	■	■	■	■	■	■		■	■	■	■	■	■		■	■		■	■	■	■	■	■	■
01111	114																											
01114	130																											
01116	130																											
01120	103	■	■	■	■	■	■	■				■	■	■	■	■	■		■	■		■	■	■	■	■	■	■
01121	103	■	■	■	■	■	■	■	■	■		■	■	■	■	■	■		■	■		■	■	■	■	■	■	■
01123	133																											
01125001	204	■	■	■	■	■	■	■	■	■		■	■	■	■	■	■		■	■		■	■	■	■	■	■	■
01126	204	■	■	■	■	■	■	■	■	■		■	■	■	■	■	■		■	■		■	■	■	■	■	■	■
01127	444																											
01127	452																											
01128	444																											
01128	452																											
01129	127	■	■	■	■	■	■	■	■	■		■	■	■	■	■	■		■	■		■	■	■	■	■	■	■
01129	444	■	■	■	■	■	■	■	■	■		■	■	■	■	■	■		■	■		■	■	■	■	■	■	■
01129	452	■	■	■	■	■	■	■	■	■		■	■	■	■	■	■		■	■		■	■	■	■	■	■	■
01130	98	■	■	■	■	■	■	■	■	■		■	■	■	■	■	■		■	■		■	■	■	■	■	■	■
01131	133	■	■																■									
01132	133	■	■										■															
01137	133	■	■										■						■									
01138	127	■	■	■	■	■	■	■	■	■		■	■	■	■	■	■		■	■		■	■	■	■	■	■	■
0114901	105	■	■	■	■	■	■	■	■	■		■	■	■	■	■	■		■	■		■	■	■	■	■	■	■
01150001	204	■	■	■	■	■	■	■	■	■		■	■	■	■	■	■		■	■		■	■	■	■	■	■	■
01151001	204	■	■	■	■	■	■	■	■	■		■	■	■	■	■	■		■	■		■	■	■	■	■	■	■
01154001	122	■	■																■									
01155001	122	■	■										■															
01157001	122	■	■	■	■	■	■	■	■	■		■	■	■	■	■	■		■	■		■	■	■	■	■	■	■
01159001	122	■	■	■	■	■	■	■	■	■		■	■	■	■	■	■		■	■		■	■	■	■	■	■	■
01160	464	■	■	■					■	■	■		■	■	■	■	■		■			■	■			■		
01161	464	■	■	■					■	■	■		■	■	■	■	■		■			■	■			■		
01162	464	■	■	■					■	■	■		■	■	■	■	■		■			■	■			■		
01163N	125	■	■										■															
01164N	122	■	■		■											■												
01165N	122																											
011691	204																											
011692	204																											
011701	128																											
011702	128																											
01171	444																											
01171	452																											
01172	444																											
01172	452																											
01174K	408	■	■	■	■	■	■	■				■	■	■	■	■	■		■	■		■	■	■	■	■	■	■
01175K	408	■	■	■	■	■	■	■				■	■	■	■	■	■		■	■		■	■	■	■	■	■	■
01175K	414	■	■	■	■	■	■	■				■	■	■	■	■	■		■	■		■	■	■	■	■	■	■
01181K	304									■																		
01183K	303																											
01184K	304	■	■										■		■	■			■	■					■	■	■	■
01185K	304	■	■		■																							
01187	304	■	■										■		■	■			■	■						■	■	■
01188	304																											

Code	Pag	SIDE-HUNG CROSS-SECTIONS TYPE															PIVOTING CROSS-SECTIONS TYPE											
		C001	C002	C003	C004	C005	C006	C007	C008	C009	C010	C011	C012	C013	C014	C015	C016	C017	P001	P002	P003	P004	P005	P006	P007	P008	P009	P010
01190	153																											
01190	434																											
0119102	105	■	■	■	■		■	■					■	■	■	■	■	■	■	■	■	■	■	■	■	■	■	■
0119102	372	■	■	■	■		■	■					■	■	■	■	■	■	■	■	■	■	■	■	■	■	■	■
0119102	381	■	■	■	■		■	■					■	■	■	■	■	■	■	■	■	■	■	■	■	■	■	■
0119102	389	■	■	■	■		■	■					■	■	■	■	■	■	■	■	■	■	■	■	■	■	■	■
0119102	399	■	■	■	■		■	■					■	■	■	■	■	■	■	■	■	■	■	■	■	■	■	■
01192	105	■	■	■	■	■	■	■	■				■	■	■	■	■	■	■	■	■	■	■	■	■	■	■	■
01192	409	■	■	■	■	■	■	■	■				■	■	■	■	■	■	■	■	■	■	■	■	■	■	■	■
01193	105	■	■	■	■	■	■	■			■			■	■	■	■	■	■	■	■	■	■	■	■	■	■	■
01194	105	■	■	■	■	■	■	■					■	■	■	■	■	■	■	■	■	■	■	■	■	■	■	■
01196	111																											
01207	408																											
01207	414																											
01209	105																											
01210	408																											
01213	295																											
01214	295																											
01215	292																											
01215	435																											
01216	283																											
01220	683																											
01221	684																											
01224	315																											
01228	320	■	■																									
01230	204	■	■	■	■	■	■	■	■	■	■	■	■	■	■	■	■	■	■	■	■	■	■	■	■	■	■	■
01239	706																											
01261	330																											
01266K	295																											
01267K	295	■	■																									
01269K	295																											
01274	685																											
01275	686																											
01280	295																											
01294N	467	■	■	■																								
01295N	467	■	■	■																								
01297	465	■	■	■																								
01298	465	■	■	■																								
01299	532																											
01299	555																											
01299	582																											
01300	465	■	■	■																								
01304	465	■	■	■																								
0130501	292																											
0130601	292																											
0130701	292																											
01308	293																											
01314K	292	■	■	■																								
0131501	292																											
0131601	292																											
01317K	292																											
01317K	435																											
01318K	292																											
01319K	286																											
01320	278																											
01322	292	■	■	■																								
01322K	292	■	■																									
0132501	293	■	■	■																								

CODE / PROFILE CROSS-SECTIONS TYPE

Code	Pag	SIDE-HUNG CROSS-SECTIONS TYPE															PIVOTING CROSS-SECTIONS TYPE											
		C001	C002	C003	C004	C005	C006	C007	C008	C009	C010	C011	C012	C013	C014	C015	C016	C017	P001	P002	P003	P004	P005	P006	P007	P008	P009	P010
01326	278	■	■	■				■					■	■	■		■	■	■	■	■				■	■		
01328	292																											
01329	292									■																		
0133001	290									■																		
01331	292																											
01332	286																											
01333	286	■	■	■		■					■		■	■	■	■	■	■	■	■	■	■	■	■	■	■	■	■
0133801	292																											
01339	292	■	■	■	■	■		■			■		■	■	■	■	■	■	■	■	■	■	■	■	■	■	■	■
01340K	292						■																					
01340N	292						■																					
01342K	292				■		■																					
01343K	292	■	■	■									■		■		■			■			■		■			
01344K	292							■																				
01344K	435							■																				
01345K	292									■																		
01347K	292	■	■	■	■		■	■			■		■	■	■	■	■	■	■	■	■	■	■	■	■	■	■	■
01347K	411	■	■	■	■		■	■			■		■	■	■	■	■	■	■	■	■	■	■	■	■	■	■	■
01347K	418	■	■	■	■		■	■			■		■	■	■	■	■	■	■	■	■	■	■	■	■	■	■	■
01347K	423	■	■	■	■		■	■			■		■	■	■	■	■	■	■	■	■	■	■	■	■	■	■	■
01347K	427	■	■	■	■		■	■			■		■	■	■	■	■	■	■	■	■	■	■	■	■	■	■	■
01347K	431	■	■	■	■		■	■			■		■	■	■	■	■	■	■	■	■	■	■	■	■	■	■	■
01348K	292	■	■	■	■	■	■	■			■		■	■	■	■	■	■	■	■	■	■	■	■	■	■	■	■
01348K	423	■	■	■	■	■	■	■			■		■	■	■	■	■	■	■	■	■	■	■	■	■	■	■	■
01348K	427	■	■	■	■	■	■	■			■		■	■	■	■	■	■	■	■	■	■	■	■	■	■	■	■
01348K	431	■	■	■	■	■	■	■			■		■	■	■	■	■	■	■	■	■	■	■	■	■	■	■	■
01349K	292	■	■	■	■	■	■	■			■		■	■	■	■	■	■	■	■	■	■	■	■	■	■	■	■
01349K	427	■	■	■	■	■	■	■			■		■	■	■	■	■	■	■	■	■	■	■	■	■	■	■	■
01349K	431	■	■	■	■	■	■	■			■		■	■	■	■	■	■	■	■	■	■	■	■	■	■	■	■
01349K	580	■	■	■	■	■	■	■			■		■	■	■	■	■	■	■	■	■	■	■	■	■	■	■	■
01350K	300	■	■	■	■		■				■		■	■	■	■	■	■	■	■	■	■	■	■	■	■	■	■
01352K	286	■	■	■	■	■	■	■	■	■	■	■	■	■	■	■	■	■	■	■	■	■	■	■	■	■	■	■
01353K	292	■	■	■	■		■	■	■	■	■	■	■	■	■	■	■	■	■	■	■	■	■	■	■	■	■	■
01355K	331	■	■		■										■													
01356K	286																											
0135701	300								■	■																		
01362K	292	■	■	■	■								■		■	■	■	■	■	■	■	■	■	■	■	■	■	■
01373	287																											
01391	300								■																			
01394	287																											
01395	287	■	■																									
01396	292																											
01398	292																											
01399	287	■	■														■							■				
01400	292																											
01401	115	■	■						■																			
01410	301				■																							
01420	64	■	■										■							■								
01421	64	■	■																		■							
01424	64	■	■																			■						
01427	64				■																			■				
01428	64	■	■																						■			
01429	64	■	■										■								■							■
01439	64																											
01441	66																											
01443	66	■	■																									
01449	66																											
01459	64	■	■	■						■																		

Code	Pag	SIDE-HUNG CROSS-SECTIONS TYPE															PIVOTING CROSS-SECTIONS TYPE											
		C001	C002	C003	C004	C005	C006	C007	C008	C009	C010	C011	C012	C013	C014	C015	C016	C017	P001	P002	P003	P004	P005	P006	P007	P008	P009	P010
01464	64	■	■												■													
01640N	214	■	■	■				■	■					■													■	
01642N	214	■	■	■			■	■					■	■	■	■	■	■	■	■	■				■	■		■
01650N	213	■	■	■				■	■					■													■	
01652N	213	■	■	■			■	■						■	■	■	■	■	■	■	■					■	■	
01700	368																											
01701N	211	■	■	■	■						■			■	■	■	■	■	■	■	■	■	■	■	■	■	■	■
01704	210	■	■	■	■	■	■							■	■	■	■	■	■	■	■	■	■	■	■	■	■	■
0170601	210							■	■																			
01709	211																											
01711	212																											
01717	331																											
01801	347																											
01950	351						■																					
01951	351																											
01952	351	■	■												■											■		
01954	351	■	■	■							■			■	■	■	■	■	■	■	■	■	■	■	■	■	■	■
01955	351	■	■	■							■			■											■	■		■
01956	351							■	■																			
01959	351																											
01960	351																											
01961	351																											
01969001	359																											
01971	348	■	■					■									■										■	
01972	348								■																			
01974	348	■	■		■						■																	
01977001	359																											
01978001	359																											
01979001	359																											
01984	461																											
01985	461																											
01986	461																											
01987	460																											
01988	461																											
0199002	356																											
0199102	356																											
01999	359																											
02000	446																											
020021	446																											
020022	446																											
02003	457																											
02006K	349																											
02009	453																											
02011	261			■											■									■	■			
02025	88																											
02025	89																											
02025	115																											
02025	116																											
02026	88																											
02026	89																											
02026	115																											
02026	116																											
02027	88																											
02027	89																											
02027	115																											
02027	116																											
02028	88																											
02028	89																											

CODE / PROFILE CROSS-SECTIONS TYPE

Code	Pag	SIDE-HUNG CROSS-SECTIONS TYPE															PIVOTING CROSS-SECTIONS TYPE										
		C001	C002	C003	C004	C005	C006	C007	C008	C009	C010	C011	C012	C013	C014	C015	C016	C017	P001	P002	P003	P004	P005	P006	P007	P008	P009
02028	115																										
02028	116																										
02029	88																										
02029	89																										
02029	115																										
02029	116																										
02030K	364	■	■	■			■					■		■	■	■	■	■	■	■	■	■	■	■	■	■	■
02030K	479	■	■	■			■					■		■	■	■	■	■	■	■	■	■	■	■	■	■	■
02030K	499	■	■	■			■					■		■	■	■	■	■	■	■	■	■	■	■	■	■	■
02030K	510	■	■	■			■					■		■	■	■	■	■	■	■	■	■	■	■	■	■	■
02031K	364																										
02034K	364							■																			
02034K	520							■																			
02035	364								■																		
02036	355																										
02037	355																										
02038	365																										
02039	365																										
02040K	367	■	■	■	■	■								■	■	■	■	■	■	■	■	■	■	■	■	■	■
02041K	367	■	■	■	■	■								■	■	■	■	■	■	■	■	■	■	■	■	■	■
02042K	367							■																			
02043K	367							■																			
0204401	367								■																		
0204501	367								■																		
0204601	367									■																	
0204701	367									■																	
02050	88																										
02050	89																										
02050	115																										
02050	116																										
0205101	24																										
02056	454																										
02058	454																										
02059	454																										
02061	454																										
02064	448																										
02064	454																										
02065	448																										
02065	454																										
02066	455																										
02067	456																										
02070	447																										
02071	267			■											■							■	■				
02072	267	■	■			■									■	■	■	■	■	■	■	■	■	■	■	■	■
02073	267									■																	
02074	267	■	■			■									■	■	■	■	■	■	■	■	■	■	■	■	■
02075	267							■																			
02079	164																										
02080	270	■	■	■				■							■	■	■	■	■	■	■	■	■	■	■	■	■
02081	270	■	■	■				■							■	■	■	■	■	■	■	■	■	■	■	■	■
02082	270	■	■	■				■							■	■	■	■	■	■	■	■	■	■	■	■	■
02083	270	■	■	■				■							■	■	■	■	■	■	■	■	■	■	■	■	■
02085	279							■																			
02085	435							■																			
02086	135																										
02087	638																										
02101	276																										
02102	276																										

Code	Pag	SIDE-HUNG CROSS-SECTIONS TYPE															PIVOTING CROSS-SECTIONS TYPE										
		C001	C002	C003	C004	C005	C006	C007	C008	C009	C010	C011	C012	C013	C014	C015	C016	C017	P001	P002	P003	P004	P005	P006	P007	P008	P009
02108	253	■	■								■		■		■			■	■					■			
02108K	253	■	■								■		■		■	■			■	■					■		
02111K	253	■	■	■	■						■	■	■		■	■	■			■	■	■			■		
02111K	427	■	■	■	■						■	■	■		■	■	■			■	■	■			■		
02111K	431	■	■	■	■						■	■	■		■	■	■			■	■	■			■		
02111N	253	■	■	■	■						■	■	■		■	■	■			■	■	■			■		
02112	253	■	■	■										■			■					■					
02112K	253	■	■	■										■			■					■					
02113	257	■	■	■	■				■		■	■	■	■	■	■	■			■	■	■			■	■	
02114	281	■	■	■	■						■	■	■	■	■	■	■			■	■	■	■	■	■	■	■
02114K	281	■	■	■	■						■	■	■	■	■	■	■			■	■	■	■	■	■	■	■
02114K	423	■	■	■	■						■	■	■	■	■	■	■			■	■	■	■	■	■	■	■
02114K	427	■	■	■	■						■	■	■	■	■	■	■			■	■	■	■	■	■	■	■
02114K	431	■	■	■	■						■	■	■	■	■	■	■			■	■	■	■	■	■	■	■
02125	253	■	■																								
02125K	253	■	■																								
02129	303																										
02131	253								■																		
02131K	253								■																		
02131K	435								■																		
02132	253									■																	
02133	253																										
02134	253																										
02135	466	■	■	■					■	■	■		■	■	■		■			■	■			■			
02136	466	■	■						■	■	■		■							■					■		
02138K	253																										
02140	281																										
02141	281								■																		
02141K	281								■																		
02141K	435								■																		
02142	281									■																	
02143N	280	■	■								■		■								■						
02144	278	■	■						■						■								■				
02145N	280	■	■		■								■		■	■				■	■			■	■	■	■
02146	281								■																		
02149	651																										
02150	274	■	■	■					■					■			■										
02151	274	■	■	■					■					■			■										
02153	256	■	■								■		■							■	■				■		
02156	261	■	■		■						■		■		■	■				■	■				■	■	
02158	274	■	■	■					■					■			■				■						
02159	278	■	■	■					■		■	■	■		■	■	■				■	■	■		■		
02161	281	■	■												■										■		
02162	281	■	■												■										■		
02163	281	■	■												■										■		
02164	253	■	■												■							■			■		
02165	253	■	■								■		■		■	■						■			■		
02165K	253	■	■								■		■		■	■					■			■			
02166K	258			■										■									■	■			
02167K	279	■	■	■	■						■	■	■		■					■	■				■	■	
02168K	258	■	■	■	■						■	■	■		■	■	■			■	■	■		■	■	■	■
02168K	427	■	■	■	■						■	■	■		■	■	■			■	■	■		■	■	■	■
02168K	431	■	■	■	■						■	■	■		■	■	■			■	■	■		■	■	■	■
02170	272	■	■	■					■					■	■		■										
02177K	267	■	■		■		■				■		■		■					■	■				■	■	
02178	261	■	■		■						■		■		■	■				■	■				■	■	
02179	262				■																						
02180	275	■	■	■	■		■	■	■		■		■	■	■		■			■	■			■	■	■	■

CODE / PROFILE CROSS-SECTIONS TYPE

Code	Pag	SIDE-HUNG CROSS-SECTIONS TYPE															PIVOTING CROSS-SECTIONS TYPE											
		C001	C002	C003	C004	C005	C006	C007	C008	C009	C010	C011	C012	C013	C014	C015	C016	C017	P001	P002	P003	P004	P005	P006	P007	P008	P009	P010
02181	275	■	■	■	■		■	■	■	■	■		■	■	■		■	■	■		■	■	■		■	■		
02182	275	■	■	■	■		■	■	■	■	■		■	■	■		■	■	■		■	■	■		■	■		
02183	278	■	■	■	■		■	■	■	■	■		■	■	■		■	■	■		■	■	■		■	■		
02185	272																											
02186K	263	■	■										■								■							
02187	283	■	■	■	■		■						■	■	■	■	■	■	■	■	■		■	■	■	■	■	■
02187K	283	■	■	■	■		■						■	■	■	■	■	■	■	■	■		■	■	■	■	■	■
02188K	279	■	■	■	■					■	■		■		■	■	■	■	■	■	■		■	■	■	■	■	■
02188K	423	■	■	■	■					■	■		■		■	■	■	■	■	■	■		■	■	■	■	■	■
02188K	427	■	■	■	■					■	■		■		■	■	■	■	■	■	■		■	■	■	■	■	■
02188K	431	■	■	■	■					■	■		■		■	■	■	■	■	■	■		■	■	■	■	■	■
02189K	261	■	■	■	■		■						■	■	■	■	■	■	■	■	■		■	■	■	■	■	■
02191K	261	■	■		■							■	■		■	■				■	■		■	■	■		■	■
02194	135	■																										
02195K	261			■										■									■	■				
02196	331	■	■	■	■		■	■					■	■	■	■	■	■	■	■	■		■	■	■	■	■	■
02197K	305	■	■																								■	
02198	269								■	■																		
02199	269	■	■	■	■								■	■	■	■	■	■	■	■	■				■			
02215K	288																											
02223K	305	■	■												■						■		■					
02229K	298	■	■	■	■				■				■		■	■	■	■	■	■	■		■	■	■		■	■
0223001	298	■	■	■					■				■	■	■	■	■	■	■	■	■		■	■	■		■	■
02235	134	■	■	■	■		■	■	■	■	■		■	■	■	■	■	■	■	■	■		■	■	■	■	■	■
02235	415	■	■	■	■		■	■	■	■	■		■	■	■	■	■	■	■	■	■		■	■	■	■	■	■
02236	135	■	■		■								■		■								■				■	
02237	208	■	■	■					■				■	■												■	■	
02240	208	■	■	■									■	■	■						■		■			■		
02241	208	■	■	■									■	■	■						■		■			■		
02243	208	■	■	■									■	■	■						■		■			■		
02245	208	■	■	■					■					■													■	
02246	208	■	■	■									■	■	■						■		■			■		
02250	138	■	■	■					■					■													■	
02251K	124	■	■										■								■							■
02251K	139	■	■										■								■							■
02252K	124	■	■						■						■						■		■				■	
02252K	139	■	■						■						■						■		■				■	
02253K	124	■	■	■									■	■	■								■			■		
02253K	139	■	■	■									■	■	■								■			■		
02254K	124	■	■																		■							
02254K	139	■	■																		■							
02255K	124	■	■												■								■				■	
02255K	139	■	■												■								■				■	
02256K	303																											
02256N	303																											
02257	303																											
02258K	303																											
02259	206	■	■																			■						
02260	138	■	■																									
02261	138	■	■																									
02262	135																											
02270	303																											
02270K	303																											
02271	303																											
02282	330	■	■																									
02290	679																											
02296	138	■	■																			■						
02301	326																											

Code	Pag	SIDE-HUNG CROSS-SECTIONS TYPE															PIVOTING CROSS-SECTIONS TYPE											
		C001	C002	C003	C004	C005	C006	C007	C008	C009	C010	C011	C012	C013	C014	C015	C016	C017	P001	P002	P003	P004	P005	P006	P007	P008	P009	P010
02304	687																											
02309	331									■																		
02309	427									■																		
02309	431									■																		
02314	330	■	■	■	■							■	■	■		■	■	■										
02315K	286	■	■	■			■					■	■	■		■	■	■		■	■		■	■			■	
02317	210			■																■								
02319	321	■	■																		■							
02320	286																											
02326	322																											
02328	330	■	■								■					■						■				■		
02331	333																											
02332	333																											
02336	331	■	■	■	■		■		■		■		■	■	■	■	■	■	■	■	■	■	■	■	■	■	■	■
02336	427	■	■	■	■		■		■		■		■	■	■	■	■	■	■	■	■	■	■	■	■	■	■	■
02336	431	■	■	■	■		■		■		■		■	■	■	■	■	■	■	■	■	■	■	■	■	■	■	■
02337	292	■	■	■	■								■	■	■		■	■	■	■	■	■	■	■	■	■	■	■
02340	274	■	■	■					■					■									■					
02341	631																											
02352	331	■	■	■	■		■	■			■		■	■	■		■	■	■	■	■	■	■	■	■	■	■	■
02354	330								■	■																		
02357	330	■	■		■								■		■								■		■			
02359	330																											
02360	330	■	■						■	■																		
02365	323								■	■																		
02366	331								■	■																		
02366	435								■	■																		
02367	704								■	■																		
02368	315	■	■						■	■																		
02377	138								■		■																	
02379	138	■	■																									
02380	315																											
02382N	138	■	■	■			■			■			■	■	■		■	■	■	■	■	■	■	■	■	■	■	■
02383	138																											
02385	135								■																			
02385K	135								■																			
02386	135									■																		
02387	135	■	■	■	■		■	■		■			■	■	■	■	■	■	■	■	■	■	■	■	■	■	■	■
02387K	135	■	■	■	■		■	■		■			■	■	■	■	■	■	■	■	■	■	■	■	■	■	■	■
02390	331																											
02394	327																											
02403	206																											
02407	206																											
02408	206	■	■		■											■												
02414	167	■	■																									
02415	141	■	■	■					■												■	■						
02416	141																											
02422	170																											
0243001	173																											
02431	173	■	■																									
02456	171	■	■						■				■		■					■	■		■	■			■	■
02458	166																											
02473N	196																											
02474N	196																											
02476	143	■	■																									
02481N	194																											
02482N	194																											
02483	194																											

CODE / PROFILE CROSS-SECTIONS TYPE

Code	Pag	SIDE-HUNG CROSS-SECTIONS TYPE															PIVOTING CROSS-SECTIONS TYPE												
		C001	C002	C003	C004	C005	C006	C007	C008	C009	C010	C011	C012	C013	C014	C015	C016	C017	P001	P002	P003	P004	P005	P006	P007	P008	P009	P010	
02487	196																												
02491	150	■	■														■			■									
0249201	151																												
02494	151																												
02500	151																												
02505	196	■	■	■			■		■	■	■			■	■	■		■	■	■		■	■				■	■	
02518N	196																												
02521N	196																												
02522N	194																												
02541N	196																												
02542N	194																												
02543	197																												
02544	197																												
02545	197	■	■	■																■	■							■	■
02546	197	■	■	■																■	■							■	■
02547	197	■	■	■																■	■							■	■
02548	197	■	■	■																■	■							■	■
02553N	196																												
02558N	196																												
02559N	196																												
02560N	194																												
02563	168	■	■	■			■		■	■	■			■	■	■		■	■	■		■	■				■	■	
02571K	303																												
02574K	303																												
02578K	303																												
02581K	254																												
02582K	254																												
02585K	259																												
02589K	303																												
0259701	638																												
02609	215	■	■	■			■		■	■	■			■	■	■		■	■	■		■	■				■	■	
02610	215	■	■	■			■		■	■	■			■	■	■		■	■	■		■	■				■	■	
02611	215	■	■	■			■		■	■	■			■	■	■		■	■	■		■	■				■	■	
02612	657																												
02675	642																												
02676	642																												
02677	642																												
02679	642																												
02682	642																												
02691	640																												
02701	653																												
0272001	666																												
0272101	666																												
0272201	666																												
0272301	666																												
0272401	666																												
0272501	666																												
0272601	666																												
0272701	666																												
0272801	666																												
02742	268	■	■			■															■	■						■	■
02743	268										■																		
02744	268	■	■				■					■			■	■								■					
02745	268																												
02760	675																												
02761	675																												
02762	143	■	■								■																		
02762	674	■	■								■																		

Code	Pag	SIDE-HUNG CROSS-SECTIONS TYPE															PIVOTING CROSS-SECTIONS TYPE											
		C001	C002	C003	C004	C005	C006	C007	C008	C009	C010	C011	C012	C013	C014	C015	C016	C017	P001	P002	P003	P004	P005	P006	P007	P008	P009	P010
02763	143																											
02763	674																											
02764	676																											
02765	677																											
02770	673																											
02792	165	■	■																									
02800K	364																											
0288201	609																											
0289201	609																											
0289401	617																											
0289501	621																											
02914	595																											
02966N	627																											
02967V	628																											
0297802	615																											
0298201	607																											
02985	597																											
0298802	615																											
0299101	646																											
0299202	607																											
02996	628																											
03000	622	■	■																									
03018N	635																											
03041	605																											
03043	633																											
0304911	147	■	■	■	■	■	■	■				■	■	■	■	■	■	■	■	■	■	■	■	■	■	■	■	■
0304921	147	■	■	■	■	■	■	■				■	■	■	■	■	■	■	■	■	■	■	■	■	■	■	■	■
03050	633																											
03055	634																											
03061	705																											
03062	705																											
03063L	651																											
03064	633																											
03068	651																											
03069L	651																											
03079	602																											
03082	651																											
03083	651																											
03084	651																											
03085	651																											
03087	651																											
03088	651																											
03088L	651																											
03092	651																											
03098	651																											
03104	595																											
03105	597																											
03106	678																											
03108	678																											
03114	678																											
03115	602																											
03116	597																											
03118	597																											
03119X	602																											
03120	597																											
03122	598																											
03123	602																											
03124	688																											

CODE / PROFILE CROSS-SECTIONS TYPE

Code	Pag	SIDE-HUNG CROSS-SECTIONS TYPE															PIVOTING CROSS-SECTIONS TYPE											
		C001	C002	C003	C004	C005	C006	C007	C008	C009	C010	C011	C012	C013	C014	C015	C016	C017	P001	P002	P003	P004	P005	P006	P007	P008	P009	P010
03125	597																											
03132	602																											
03133	597																											
03136N	597																											
03137N	597	■	■																							■		
03138	602																											
03139	597																											
03140	689																											
03141N	597																											
03143	690																											
03144	691																											
03146N	595																											
03147N	595																											
03148N	595	■	■													■												
03149	330	■	■																									
03150	692																											
03151N	604																											
0315202	599																											
03155	706																											
03156	704																											
03166	693																											
03172	654																											
03177	654																											
03178	595																											
03183	597																											
03185N	694																											
03194	695																											
03195N	330	■	■																		■							
03196	704																											
03199X	680																											
03200	681																											
03203	332																											
03237	53	■	■	■	■	■	■	■	■	■	■	■	■	■	■	■	■	■	■	■	■	■	■	■	■	■	■	■
0323901	50	■	■	■					■				■	■	■	■			■			■						
0324001	50	■	■	■					■										■			■				■		
0324101	50	■	■	■	■				■										■								■	
0324201	50	■	■	■															■			■						
03288	466	■	■	■					■	■	■		■	■	■	■	■	■	■	■	■	■	■	■	■	■	■	■
03289	597																											
03290	595																											
03291	597																											
03297	595																											
03298	597																											
03314	696																											
03319	602																											
03326	643																											
0332701	643																											
0332801	643																											
0333001	638																											
0333101	638																											
0333301	638																											
03336	645																											
03336L	645																											
03337	644																											
03338	644																											
0334001	655																											
03345	655																											
03346	651																											

Code	Pag	SIDE-HUNG CROSS-SECTIONS TYPE															PIVOTING CROSS-SECTIONS TYPE												
		C001	C002	C003	C004	C005	C006	C007	C008	C009	C010	C011	C012	C013	C014	C015	C016	C017	P001	P002	P003	P004	P005	P006	P007	P008	P009	P010	
03351	623																												
03352	625																												
03353	624																												
03360V	635																												
03361V	637																												
03384	697																												
03389	644																												
03390	597																												
03397	597																												
03398	595																												
03462	698																												
03463	315																												
03467	699																												
03471	597																												
03472	597																												
03473	595																												
03474	135																												
03474K	135																												
03479	700																												
03485	701																												
03491	702																												
03507	703																												
03520	532	■	■	■		■	■						■	■	■	■	■	■	■	■	■	■	■	■	■	■	■	■	■
03520	544	■	■	■		■	■						■	■	■	■	■	■	■	■	■	■	■	■	■	■	■	■	■
03520	555	■	■	■		■	■						■	■	■	■	■	■	■	■	■	■	■	■	■	■	■	■	■
03524N	283	■	■										■			■					■								
03525	283											■																	
03526N	283																												
03528	582	■	■	■	■		■	■					■	■	■	■	■	■	■	■	■	■	■	■	■	■	■	■	■
03529	604																												
03534	597																												
03535	479	■	■	■	■		■	■					■	■	■	■	■	■	■	■	■	■	■	■	■	■	■	■	■
03535	499	■	■	■	■		■	■					■	■	■	■	■	■	■	■	■	■	■	■	■	■	■	■	■
03535	510	■	■	■	■		■	■					■	■	■	■	■	■	■	■	■	■	■	■	■	■	■	■	■
03536	80																												
03539	604																												
03546	74																												
03547	74																												
03548	520																												
03557	597																												
03558	604																												
0373301	657																												
0373401	657																												
03900	54																												
03901	278																												
03930	643																												
03947	643																												
0395301	78	■	■	■	■		■	■					■	■	■	■	■	■	■	■	■	■	■	■	■	■	■	■	■
03954	79	■	■	■	■		■	■					■	■	■	■	■	■	■	■	■	■	■	■	■	■	■	■	■
0395501	477	■	■	■	■		■	■					■	■	■	■	■	■	■	■	■	■	■	■	■	■	■	■	■
0395501	488	■	■	■	■		■	■					■	■	■	■	■	■	■	■	■	■	■	■	■	■	■	■	■
0395501	497	■	■	■	■		■	■					■	■	■	■	■	■	■	■	■	■	■	■	■	■	■	■	■
0395501	508	■	■	■	■		■	■					■	■	■	■	■	■	■	■	■	■	■	■	■	■	■	■	■
0395501	528	■	■	■	■		■	■					■	■	■	■	■	■	■	■	■	■	■	■	■	■	■	■	■
0395501	542	■	■	■	■		■	■					■	■	■	■	■	■	■	■	■	■	■	■	■	■	■	■	■
0395501	552	■	■	■	■		■	■					■	■	■	■	■	■	■	■	■	■	■	■	■	■	■	■	■
0395501	579	■	■	■	■		■	■					■	■	■	■	■	■	■	■	■	■	■	■	■	■	■	■	■
03962	77	■	■	■	■		■	■					■	■	■	■	■	■	■	■	■	■	■	■	■	■	■	■	■

CODE / PROFILE CROSS-SECTIONS TYPE

Code	Pag	SIDE-HUNG CROSS-SECTIONS TYPE															PIVOTING CROSS-SECTIONS TYPE											
		C001	C002	C003	C004	C005	C006	C007	C008	C009	C010	C011	C012	C013	C014	C015	C016	C017	P001	P002	P003	P004	P005	P006	P007	P008	P009	P010
03963	76	■	■	■	■		■	■					■	■	■		■	■	■	■	■	■	■	■	■	■	■	
03978	682																											
04000	374	■	■	■	■		■	■					■	■	■	■	■	■	■	■	■	■	■	■	■	■	■	■
04000	383	■	■	■	■		■	■					■	■	■	■	■	■	■	■	■	■	■	■	■	■	■	■
04005	382	■	■	■	■		■	■					■	■	■	■	■	■	■	■	■	■	■	■	■	■	■	■
04005	400	■	■	■	■		■	■					■	■	■	■	■	■	■	■	■	■	■	■	■	■	■	■
04007	373	■	■	■	■		■	■					■	■	■	■	■	■	■	■	■	■	■	■	■	■	■	■
04007	390	■	■	■	■		■	■					■	■	■	■	■	■	■	■	■	■	■	■	■	■	■	■
04009	391	■	■	■	■		■	■					■	■	■	■	■	■	■	■	■	■	■	■	■	■	■	■
04009	401	■	■	■	■		■	■					■	■	■	■	■	■	■	■	■	■	■	■	■	■	■	■
04012	544	■	■	■												■	■	■					■			■		
04014K	532																											
04014K	544																											
04014K	555																											
04014K	580																											
04014K	582																											
04017K	282																											
04017K	520																											
04017K	570																											
04019K	282	■	■	■	■		■	■					■	■	■	■	■	■	■	■	■	■	■	■	■	■	■	■
04019K	411	■	■	■	■		■	■					■	■	■	■	■	■	■	■	■	■	■	■	■	■	■	■
04019K	532	■	■	■	■		■	■					■	■	■	■	■	■	■	■	■	■	■	■	■	■	■	■
04019K	544	■	■	■	■		■	■					■	■	■	■	■	■	■	■	■	■	■	■	■	■	■	■
04019K	555	■	■	■	■		■	■					■	■	■	■	■	■	■	■	■	■	■	■	■	■	■	■
04019K	580	■	■	■	■		■	■					■	■	■	■	■	■	■	■	■	■	■	■	■	■	■	■
04020K	282	■	■	■	■		■			■			■	■	■	■	■	■	■	■	■	■	■	■	■	■	■	■
04020K	532	■	■	■	■		■			■			■	■	■	■	■	■	■	■	■	■	■	■	■	■	■	■
04020K	544	■	■	■	■		■			■			■	■	■	■	■	■	■	■	■	■	■	■	■	■	■	■
04020K	555	■	■	■	■		■			■			■	■	■	■	■	■	■	■	■	■	■	■	■	■	■	■
04023K	282			■																								
04023K	561			■																								
04024K	479	■	■	■	■								■	■	■	■	■	■	■	■	■	■	■	■	■	■	■	■
04024K	489	■	■	■	■								■	■	■	■	■	■	■	■	■	■	■	■	■	■	■	■
04024K	499	■	■	■	■								■	■	■	■	■	■	■	■	■	■	■	■	■	■	■	■
04024K	510	■	■	■	■								■	■	■	■	■	■	■	■	■	■	■	■	■	■	■	■
04024K	532	■	■	■	■								■	■	■	■	■	■	■	■	■	■	■	■	■	■	■	■
04024K	544	■	■	■	■								■	■	■	■	■	■	■	■	■	■	■	■	■	■	■	■
04024K	555	■	■	■	■								■	■	■	■	■	■	■	■	■	■	■	■	■	■	■	■
04026K	532	■	■	■	■		■	■					■	■	■	■	■	■	■	■	■	■	■	■	■	■	■	■
04026K	544	■	■	■	■		■	■					■	■	■	■	■	■	■	■	■	■	■	■	■	■	■	■
04026K	555	■	■	■	■		■	■					■	■	■	■	■	■	■	■	■	■	■	■	■	■	■	■
04026K	580	■	■	■	■		■	■					■	■	■	■	■	■	■	■	■	■	■	■	■	■	■	■
04026K	582	■	■	■	■		■	■					■	■	■	■	■	■	■	■	■	■	■	■	■	■	■	■
04027K	286	■	■	■	■		■	■					■	■	■	■	■	■	■	■	■	■	■	■	■	■	■	■
04027K	418	■	■	■	■		■	■					■	■	■	■	■	■	■	■	■	■	■	■	■	■	■	■
04027K	423	■	■	■	■		■	■					■	■	■	■	■	■	■	■	■	■	■	■	■	■	■	■
04027K	427	■	■	■	■		■	■					■	■	■	■	■	■	■	■	■	■	■	■	■	■	■	■
04027K	431	■	■	■	■		■	■					■	■	■	■	■	■	■	■	■	■	■	■	■	■	■	■
04030K	286	■	■	■	■		■		■	■			■	■	■	■	■	■	■	■	■	■	■	■	■	■	■	■
04030K	435	■	■	■	■		■		■	■			■	■	■	■	■	■	■	■	■	■	■	■	■	■	■	■
04031K	297	■	■	■	■		■	■					■	■	■	■	■	■	■	■	■	■	■	■	■	■	■	■
0404101	297																											
04042K	286	■	■													■												
04045K	264	■	■																									
04046K	297	■	■	■	■		■	■					■	■	■	■	■	■	■	■	■	■	■	■	■	■	■	■
04047K	289	■	■	■	■		■	■					■	■	■	■	■	■	■	■	■	■	■	■	■	■	■	■
04048	411																											
04048	418																											

Code	Pag	SIDE-HUNG CROSS-SECTIONS TYPE															PIVOTING CROSS-SECTIONS TYPE											
		C001	C002	C003	C004	C005	C006	C007	C008	C009	C010	C011	C012	C013	C014	C015	C016	C017	P001	P002	P003	P004	P005	P006	P007	P008	P009	P010
04049	286																											
04050	286																											
04052	287	■	■													■												
04054	287																											
04067	286																											
04070	209	■	■	■									■	■	■		■	■	■		■	■				■	■	
04071N	206	■	■	■	■		■	■	■	■	■		■	■	■		■	■	■		■	■				■	■	
0407601	209									■																		
04080	206	■	■	■	■		■		■				■	■	■					■			■	■			■	
04082	160																											
04083	160	■	■														■					■						
04084	160	■	■																				■					
04085	140																											
04086	160																											
04089	162																											
04091	117																											
04091	123																											
04093	157	■	■																									
04094	157	■	■																									
04096	174	■	■																									
04097001	117																											
04097001	123																											
04098001	117	■	■																									
04098001	123	■	■																									
04099001	117	■	■		■								■		■	■					■						■	■
04099001	123	■	■		■								■		■	■					■						■	■
04104	117																											
04104	123																											
04105	117																											
04105	123																											
04106	160																											
04107	392	■	■	■	■		■	■					■	■	■	■	■	■	■	■	■	■	■	■	■	■	■	■
04107	402	■	■	■	■		■	■					■	■	■	■	■	■	■	■	■	■	■	■	■	■	■	■
04108	157	■	■																									
04109	657																											
04143	160																											
04144	160																											
04145	160																											
04146	160																											
04147	160																											
04148	160																											
04149	160																											
04151	160																											
04152	160																											
04153	69	■	■	■	■	■	■	■	■	■	■	■	■	■	■	■	■	■	■	■	■	■	■	■	■	■	■	■
04153	422	■	■	■	■	■	■	■	■	■	■	■	■	■	■	■	■	■	■	■	■	■	■	■	■	■	■	■
04153	426	■	■	■	■	■	■	■	■	■	■	■	■	■	■	■	■	■	■	■	■	■	■	■	■	■	■	■
04153	430	■	■	■	■	■	■	■	■	■	■	■	■	■	■	■	■	■	■	■	■	■	■	■	■	■	■	■
04153	434	■	■	■	■	■	■	■	■	■	■	■	■	■	■	■	■	■	■	■	■	■	■	■	■	■	■	■
04154	69	■	■	■	■	■	■	■	■	■	■	■	■	■	■	■	■	■	■	■	■	■	■	■	■	■	■	■
04154	422	■	■	■	■	■	■	■	■	■	■	■	■	■	■	■	■	■	■	■	■	■	■	■	■	■	■	■
04154	426	■	■	■	■	■	■	■	■	■	■	■	■	■	■	■	■	■	■	■	■	■	■	■	■	■	■	■
04154	430	■	■	■	■	■	■	■	■	■	■	■	■	■	■	■	■	■	■	■	■	■	■	■	■	■	■	■
04154	434	■	■	■	■	■	■	■	■	■	■	■	■	■	■	■	■	■	■	■	■	■	■	■	■	■	■	■
04155	69	■	■	■	■	■	■	■	■	■	■	■	■	■	■	■	■	■	■	■	■	■	■	■	■	■	■	■
04155	422	■	■	■	■	■	■	■	■	■	■	■	■	■	■	■	■	■	■	■	■	■	■	■	■	■	■	■
04155	426	■	■	■	■	■	■	■	■	■	■	■	■	■	■	■	■	■	■	■	■	■	■	■	■	■	■	■
04155	430	■	■	■	■	■	■	■	■	■	■	■	■	■	■	■	■	■	■	■	■	■	■	■	■	■	■	■

CODE / PROFILE CROSS-SECTIONS TYPE

Code	Pag	SIDE-HUNG CROSS-SECTIONS TYPE															PIVOTING CROSS-SECTIONS TYPE										
		C001	C002	C003	C004	C005	C006	C007	C008	C009	C010	C011	C012	C013	C014	C015	C016	C017	P001	P002	P003	P004	P005	P006	P007	P008	P009
04155	434	■	■	■	■	■	■	■	■	■	■	■	■	■	■	■	■	■	■	■	■	■	■	■	■	■	■
04156	69	■	■	■				■																			
04156	422	■	■	■				■																			
04156	426	■	■	■				■																			
04156	430	■	■	■				■																			
04156	434	■	■	■				■																			
04157	101																										
04158	101																										
04164	69	■	■																								
04202	530	■	■	■	■		■	■					■	■	■	■	■	■	■	■	■	■	■	■	■	■	■
04202	553	■	■	■	■		■	■					■	■	■	■	■	■	■	■	■	■	■	■	■	■	■
04203	530	■	■	■	■		■	■					■	■	■	■	■	■	■	■	■	■	■	■	■	■	■
04203	553	■	■	■	■		■	■					■	■	■	■	■	■	■	■	■	■	■	■	■	■	■
042061	541	■	■										■		■	■									■	■	■
042062	541	■	■										■		■	■									■	■	■
042071	541	■	■										■		■	■									■	■	■
042072	541	■	■										■		■	■									■	■	■
042091	541	■	■												■										■		
042092	541	■	■												■										■		
0421101	589	■	■	■			■	■					■	■	■	■								■	■	■	■
0421701	589										■																
04222	530																										
0422301	589	■	■												■											■	
0422701	589											■															
0422901	569																										
0423001	569																										
04231	261																										
0424001	590																										
0424101	590	■	■	■									■	■	■	■								■	■	■	■
0424601	590																										
0424701	590																										
0426001	255																										
04265K	255																										
04266	255																										
04267	255																										
04274K	255	■	■		■								■		■	■								■	■	■	■
04277K	255																										
04278K	255				■										■												
04280	265	■	■		■								■		■	■									■	■	■
04282K	265	■	■		■								■		■	■									■	■	■
04284	378	■	■	■	■										■	■	■							■	■	■	■
04284	386	■	■	■	■										■	■	■							■	■	■	■
04284	396	■	■	■	■										■	■	■							■	■	■	■
04284	405	■	■	■	■										■	■	■							■	■	■	■
04284	442	■	■	■	■										■	■	■							■	■	■	■
04284	530	■	■	■	■										■	■	■							■	■	■	■
04284	553	■	■	■	■										■	■	■							■	■	■	■
04285	378	■	■	■	■										■	■	■							■	■	■	■
04285	396	■	■	■	■										■	■	■							■	■	■	■
04285	442	■	■	■	■										■	■	■							■	■	■	■
04285	530	■	■	■	■										■	■	■							■	■	■	■
04285	553	■	■	■	■										■	■	■							■	■	■	■
04300	375	■	■	■	■		■	■					■	■	■	■	■							■	■	■	■
04300	393	■	■	■	■		■	■					■	■	■	■	■							■	■	■	■
04301K	411	■	■	■	■		■	■					■	■	■	■	■							■	■	■	■
04301K	479	■	■	■	■		■	■					■	■	■	■	■							■	■	■	■
04301K	489	■	■	■	■		■	■					■	■	■	■	■							■	■	■	■
04301K	499	■	■	■	■		■	■					■	■	■	■	■							■	■	■	■

CODE / PROFILE CROSS-SECTIONS TYPE

Code	Pag	SIDE-HUNG CROSS-SECTIONS TYPE															PIVOTING CROSS-SECTIONS TYPE												
		C001	C002	C003	C004	C005	C006	C007	C008	C009	C010	C011	C012	C013	C014	C015	C016	C017	P001	P002	P003	P004	P005	P006	P007	P008	P009	P010	
04357	499	■	■	■	■		■	■					■	■	■	■	■	■	■		■	■		■	■	■	■	■	■
04357	510	■	■	■	■		■	■					■	■	■	■	■	■	■	■		■	■		■	■	■	■	■
04358	299	■	■	■	■		■	■					■	■	■	■	■	■	■	■		■	■		■	■	■	■	■
043591	476	■	■	■	■		■	■					■	■	■	■	■	■	■	■		■	■		■	■	■	■	■
043592	476	■	■	■	■		■	■					■	■	■	■	■	■	■	■		■	■		■	■	■	■	■
04362	19	■	■																										
04362	416	■	■																										
04363	19	■	■																										
04363	416	■	■																										
0436411	15																												
0436411	511																												
0436421	15																												
0436421	511																												
0436511	507																												
0436521	507																												
0436611	507																												
0436621	507																												
04371	477	■	■	■	■	■	■	■					■	■	■	■	■	■	■	■	■	■	■	■	■	■	■	■	
04371	488	■	■	■	■	■	■	■					■	■	■	■	■	■	■	■	■	■	■	■	■	■	■	■	
04371	497	■	■	■	■	■	■	■					■	■	■	■	■	■	■	■	■	■	■	■	■	■	■	■	
04371	508	■	■	■	■	■	■	■					■	■	■	■	■	■	■	■	■	■	■	■	■	■	■	■	
04371	528	■	■	■	■	■	■	■					■	■	■	■	■	■	■	■	■	■	■	■	■	■	■	■	
04371	542	■	■	■	■	■	■	■					■	■	■	■	■	■	■	■	■	■	■	■	■	■	■	■	
04371	552	■	■	■	■	■	■	■					■	■	■	■	■	■	■	■	■	■	■	■	■	■	■	■	
04371	579	■	■	■	■	■	■	■					■	■	■	■	■	■	■	■	■	■	■	■	■	■	■	■	
04380	569							■																					
04395	73																												
04395	440																												
04396	73																												
04396	440																												
04397	73																												
04397	440																												
04398	73																												
04398	440																												
04399	73																												
044001	23	■	■										■		■	■					■	■			■	■	■	■	
044001	545	■	■										■		■	■					■	■			■	■	■	■	
044002	23	■	■										■		■	■					■	■			■	■	■	■	
044002	545	■	■										■		■	■					■	■			■	■	■	■	
04407	544	■	■																										
04409	544	■	■	■											■		■						■	■		■			
04411	544																												
04423	571																												
044241	13	■	■	■																									
044241	410	■	■	■																									
044241	429	■	■	■																									
044241	500	■	■	■																									
044242	13	■	■	■																									
044242	410	■	■	■																									
044242	429	■	■	■																									
044242	500	■	■	■																									
044251	377	■	■	■																									
044251	385	■	■	■																									
044251	395	■	■	■																									
044251	404	■	■	■																									
044251	496	■	■	■																									
044252	377	■	■	■																									
044252	385	■	■	■																									

Code	Pag	SIDE-HUNG CROSS-SECTIONS TYPE															PIVOTING CROSS-SECTIONS TYPE											
		C001	C002	C003	C004	C005	C006	C007	C008	C009	C010	C011	C012	C013	C014	C015	C016	C017	P001	P002	P003	P004	P005	P006	P007	P008	P009	P010
044252	395	■	■	■																								
044252	404	■	■	■																								
044252	496	■	■	■																								
044261	377	■	■	■																								
044261	395	■	■	■																								
044261	496	■	■	■																								
044262	377	■	■	■																								
044262	395	■	■	■																								
044262	496	■	■	■																								
04462N	191																											
04463N	191																											
04464N	191																											
04465N	191																											
04466N	191																											
04467N	191																											
04469N	188																											
04470N	188																											
04471N	188																											
04472N	188																											
04473N	188																											
04474N	188																											
04476N	173	■	■																									
04490N	188	■	■																									
04491N	188																											
04492N	188																											
04493N	188																											
04494N	188	■	■																									
04495N	188																											
04496N	189																											
04497N	189																											
04498N	189																											
04499N	189																											
04500N	189																											
0450701	588									■																		
0451601	588																											
0452901	588							■	■																			
0453001	638	■	■																									
04542	597																											
04545	602																											
04546	597																											
04549	597																											
04559	603																											
04560	595																											
04561	602																											
04563	597																											
04572	597																											
0457701	638																											
0457901	638																											
0458001	638																											
0458101	638																											
0458201	638																											
0458301	638																											
0458401	638																											
0458601	638																											
0458801	638																											
0458901	638																											
0459001	638																											
0459101	638																											

CODE / PROFILE CROSS-SECTIONS TYPE

Code	Pag	SIDE-HUNG CROSS-SECTIONS TYPE															PIVOTING CROSS-SECTIONS TYPE											
		C001	C002	C003	C004	C005	C006	C007	C008	C009	C010	C011	C012	C013	C014	C015	C016	C017	P001	P002	P003	P004	P005	P006	P007	P008	P009	P010
0459201	638																											
0459401	638																											
04598	641																											
04600	597																											
04607N	191																											
0461301	179																											
0461401	179																											
0461501	179	■	■																									
04616	181	■	■																									
04617	181																											
04618	181	■	■																									
0461901	179																											
0462001	179																											
0462101	179	■	■																									
04623	181																											
04624	181	■	■												■													
0462701	176																											
0462801	176	■	■																									
04630	186	■	■										■										■					
04633	191																											
04634	191																											
04635	193																											
04636	191																											
04638	193																											
04639	186																											
04645	178	■	■										■											■				
04646	178	■	■										■			■								■				
04647	191																											
04648K	520								■																			
04648K	570								■																			
04649	178	■	■																									
04650	178	■	■																									
04652N	188	■	■																									
04653N	188	■	■																									
04654N	188	■	■																									
04655	186	■	■													■								■				
0465801	186																											
04659	178																											
04665N	191																											
04666N	193																											
04667N	193																											
04671K	560	■	■										■		■				■	■		■	■			■	■	
04675K	288																											
04677K	288																											
04679K	288																											
04685	643																											
04688	645																											
04690	645																											
0469401	646																											
0469501	638																											
04698	178																											
04699	178																											
04704	477	■	■	■	■		■	■					■	■	■	■	■	■	■	■	■	■	■	■	■	■	■	■
04704	488	■	■	■	■		■	■					■	■	■	■	■	■	■	■	■	■	■	■	■	■	■	■
04704	497	■	■	■	■		■	■					■	■	■	■	■	■	■	■	■	■	■	■	■	■	■	■
04704	508	■	■	■	■		■	■					■	■	■	■	■	■	■	■	■	■	■	■	■	■	■	■
04704	528	■	■	■	■		■	■					■	■	■	■	■	■	■	■	■	■	■	■	■	■	■	■
04704	542	■	■	■	■		■	■					■	■	■	■	■	■	■	■	■	■	■	■	■	■	■	■

Code	Pag	SIDE-HUNG CROSS-SECTIONS TYPE															PIVOTING CROSS-SECTIONS TYPE											
		C001	C002	C003	C004	C005	C006	C007	C008	C009	C010	C011	C012	C013	C014	C015	C016	C017	P001	P002	P003	P004	P005	P006	P007	P008	P009	P010
04704	552	■	■	■	■		■	■					■	■	■	■	■	■	■	■	■	■	■	■	■	■	■	
04704	579	■	■	■	■		■	■					■	■	■	■	■	■	■	■	■	■	■	■	■	■	■	
04704010	477	■	■		■																							
04704010	488	■	■		■																							
04704010	497	■	■		■																							
04704010	508	■	■		■																							
04704010	528	■	■		■																							
04704010	542	■	■		■																							
04704010	579	■	■		■																							
0470501	477	■	■		■	■	■						■	■	■	■	■	■										
0470501	488	■	■		■	■	■						■	■	■	■	■	■										
0470501	497	■	■		■	■	■						■	■	■	■	■	■										
0470501	508	■	■		■	■	■						■	■	■	■	■	■										
0470501	528	■	■		■	■	■						■	■	■	■	■	■										
0470501	542	■	■		■	■	■						■	■	■	■	■	■										
0470501	552	■	■		■	■	■						■	■	■	■	■	■										
04706N	477	■	■	■	■		■	■					■	■	■	■	■	■	■	■	■	■	■	■	■	■	■	■
04706N	488	■	■	■	■		■	■					■	■	■	■	■	■	■	■	■	■	■	■	■	■	■	■
04706N	497	■	■	■	■		■	■					■	■	■	■	■	■	■	■	■	■	■	■	■	■	■	■
04706N	508	■	■	■	■		■	■					■	■	■	■	■	■	■	■	■	■	■	■	■	■	■	■
04706N	528	■	■	■	■		■	■					■	■	■	■	■	■	■	■	■	■	■	■	■	■	■	■
04706N	542	■	■	■	■		■	■					■	■	■	■	■	■	■	■	■	■	■	■	■	■	■	■
04706N	552	■	■	■	■		■	■					■	■	■	■	■	■	■	■	■	■	■	■	■	■	■	■
04706N	579	■	■	■	■		■	■					■	■	■	■	■	■	■	■	■	■	■	■	■	■	■	■
0470701	477	■	■		■	■	■						■	■	■	■	■	■										
0470701	488	■	■		■	■	■						■	■	■	■	■	■										
0470701	497	■	■		■	■	■						■	■	■	■	■	■										
0470701	508	■	■		■	■	■						■	■	■	■	■	■										
0470701	528	■	■		■	■	■						■	■	■	■	■	■										
0470701	542	■	■		■	■	■						■	■	■	■	■	■										
0470701	552	■	■		■	■	■						■	■	■	■	■	■										
04711	378	■	■	■	■		■	■					■	■	■	■	■	■	■	■	■	■	■	■	■	■	■	■
04711	386	■	■	■	■		■	■					■	■	■	■	■	■	■	■	■	■	■	■	■	■	■	■
04711	396	■	■	■	■		■	■					■	■	■	■	■	■	■	■	■	■	■	■	■	■	■	■
04711	405	■	■	■	■		■	■					■	■	■	■	■	■	■	■	■	■	■	■	■	■	■	■
04711	442	■	■	■	■		■	■					■	■	■	■	■	■	■	■	■	■	■	■	■	■	■	■
04711	527	■	■	■	■		■	■					■	■	■	■	■	■	■	■	■	■	■	■	■	■	■	■
04711	534	■	■	■	■		■	■					■	■	■	■	■	■	■	■	■	■	■	■	■	■	■	■
04711010	527	■	■		■																							
04718	551	■	■										■															
04721	567																											
04721	571																											
04727	584	■	■																									
04728	534	■	■	■	■																							
04739	577	■	■	■	■		■	■					■	■	■	■	■	■	■	■	■	■	■	■	■	■	■	■
04739	584	■	■	■	■		■	■					■	■	■	■	■	■	■	■	■	■	■	■	■	■	■	■
04766N	518																											
04766N	568																											
04767V	518																											
04767V	568																											
04768N	518																											
04768N	568																											
04770K	479	■	■	■	■		■	■					■	■	■	■	■	■	■	■	■	■	■	■	■	■	■	■
04770K	489	■	■	■	■		■	■					■	■	■	■	■	■	■	■	■	■	■	■	■	■	■	■
04770K	499	■	■	■	■		■	■					■	■	■	■	■	■	■	■	■	■	■	■	■	■	■	■
04770K	510	■	■	■	■		■	■					■	■	■	■	■	■	■	■	■	■	■	■	■	■	■	■
04770K	532	■	■	■	■		■	■					■	■	■	■	■	■	■	■	■	■	■	■	■	■	■	■
04770K	544	■	■	■	■		■	■					■	■	■	■	■	■	■	■	■	■	■	■	■	■	■	■

CODE / PROFILE CROSS-SECTIONS TYPE

Code	Pag	SIDE-HUNG CROSS-SECTIONS TYPE															PIVOTING CROSS-SECTIONS TYPE										
		C001	C002	C003	C004	C005	C006	C007	C008	C009	C010	C011	C012	C013	C014	C015	C016	C017	P001	P002	P003	P004	P005	P006	P007	P008	P009
04770K	555	■	■	■	■		■	■					■	■	■	■	■	■	■	■	■	■	■	■	■	■	■
04777K	411	■	■	■	■		■	■			■		■	■	■	■	■	■	■	■	■	■	■	■	■	■	■
04777K	479	■	■	■	■		■	■			■		■	■	■	■	■	■	■	■	■	■	■	■	■	■	■
04777K	489	■	■	■	■		■	■			■		■	■	■	■	■	■	■	■	■	■	■	■	■	■	■
04777K	499	■	■	■	■		■	■			■		■	■	■	■	■	■	■	■	■	■	■	■	■	■	■
04777K	510	■	■	■	■		■	■			■		■	■	■	■	■	■	■	■	■	■	■	■	■	■	■
04777K	532	■	■	■	■		■	■			■		■	■	■	■	■	■	■	■	■	■	■	■	■	■	■
04777K	544	■	■	■	■		■	■			■		■	■	■	■	■	■	■	■	■	■	■	■	■	■	■
04777K	555	■	■	■	■		■	■			■		■	■	■	■	■	■	■	■	■	■	■	■	■	■	■
04778	582																										
04850	183																										
04851	183																										
04852	183	■	■																								
04854	182																										
04855	182	■	■																								
04859	186	■	■																								
04860	186	■	■																								
04861	186	■	■																								
04862	186	■	■																								
04865	638																										
0488801	648																										
0489101	648																										
0489301	648																										
0489401	648																										
0489501	648																										
0489601	648																										
0489701	648																										
0489901	648																										
0490201	648																										
04902L1	648																										
0490301	648																										
0490401	648																										
0490501	648																										
0491001	648																										
04912L1	648																										
0491301	648																										
0491601	648																										
0491701	648																										
0491902	648																										
0492001	648																										
0492101	648																										
04922	646																										
04923	640																										
04924	640																										
0496601	648																										
0499002	638																										
0499101	638																										
0499202	638																										
04994L1	648																										
0499902	638																										
0500201	649																										
0500401	638																										
05005	649																										
050071	100				■																						
050072	100																										
05008	100				■																						
050081	100				■																						
05011	641																										

Code	Pag	SIDE-HUNG CROSS-SECTIONS TYPE															PIVOTING CROSS-SECTIONS TYPE											
		C001	C002	C003	C004	C005	C006	C007	C008	C009	C010	C011	C012	C013	C014	C015	C016	C017	P001	P002	P003	P004	P005	P006	P007	P008	P009	P010
05052	53	■	■	■			■		■	■			■	■	■		■	■	■		■		■	■	■			
05053	54	■	■	■			■		■	■			■	■	■	■	■	■	■		■		■		■	■	■	
05054	54	■	■							■																		
05095	46	■	■																									
05096	46	■	■						■																			
05097	46	■	■																									
05098	46	■	■																									
05120V	45	■	■	■	■	■			■				■	■	■								■	■	■	■	■	■
05121V	45	■	■	■	■		■		■				■	■	■								■	■	■	■	■	■
05122V	45	■	■		■																							
05125V	45																											
05132V	45																											
05134V	45	■	■	■									■	■							■	■						
05135V	45	■	■	■									■	■							■	■						■
05136V	45	■	■	■					■	■				■	■								■			■		
05137V	45	■	■	■					■	■				■	■								■			■		
05158V	39												■															
05159V	39																											
05160V	39	■	■	■	■	■			■				■	■	■								■	■	■	■	■	■
05161V	39	■	■	■	■	■			■				■	■	■								■	■	■	■	■	■
05162V	39				■																							
05163V	39				■																							
05164V	39																											
05165V	39																											
05166V	39	■	■	■				■	■	■			■	■	■	■	■	■	■	■	■		■	■	■	■	■	■
05167V	39	■	■	■				■	■	■			■	■	■	■	■	■	■	■	■		■	■	■	■	■	■
05168V	39	■	■	■					■	■																	■	
05169V	39	■	■						■	■			■															■
05170V	39	■	■												■								■					
05171V	39	■	■												■								■					
05172V	39																											
05174V	39	■	■	■									■	■									■	■				■
05175V	39	■	■	■									■	■									■	■				■
05176V	39	■	■	■					■	■				■	■								■			■		
05178V	39					■																						
05179V	39					■																						
05180N	42																											
05182N	42																											
05195	46	■	■																				■					
05196	46	■	■						■	■																		
05197	46	■	■			■																						
05198	46	■	■																									
05199	46																											
0520001	47	■	■			■			■				■		■								■		■			
0520101	47	■	■			■			■				■										■		■			
0520201	47	■	■			■			■	■													■					
0520301	47	■	■			■			■	■													■					
0520401	49	■	■							■			■													■		
0520501	49	■	■							■														■				
05241	52																											
05242	52																											
05243	52	■	■	■	■	■	■	■	■	■			■	■	■	■	■	■	■	■	■	■	■	■	■	■	■	■
05244	52	■	■	■	■	■	■	■	■	■			■	■	■	■	■	■	■	■	■	■	■	■	■	■	■	■
05261	71																											
052621	71																											
052622	71																											
052831	17								■																			
052831	433								■																			

CODE / PROFILE CROSS-SECTIONS TYPE

Code	Pag	SIDE-HUNG CROSS-SECTIONS TYPE															PIVOTING CROSS-SECTIONS TYPE											
		C001	C002	C003	C004	C005	C006	C007	C008	C009	C010	C011	C012	C013	C014	C015	C016	C017	P001	P002	P003	P004	P005	P006	P007	P008	P009	P010
052831	521						■																					
052832	17						■																					
052832	433						■																					
052832	521						■																					
052841	517						■																					
052842	517						■																					
052851	517						■																					
052852	517						■																					
052861	517						■																					
052862	517						■																					
05287	520						■																					
05288	299						■																					
05288	435						■																					
05289	489												■	■	■	■	■											
052901	11																											
052901	490																											
052902	11																											
052902	490																											
0529111	486																											
0529121	486																											
0529211	486																											
0529221	486																											
05293	11												■	■	■	■	■											
05293	487												■	■	■	■	■											
05294	300	■	■	■																								
05295	21						■																					
05295	417						■																					
05296	21						■																					
05296	417						■																					
05300	48	■	■																									
05301	48	■	■																									
05302	48	■	■																									
05303	48																											
05306	578																											
05307	578																											
05308	578																											
05309	578																											
05310	578																											
05311	580																											
05312	580																											
05313	580																											
05560	71																											
05980	191																											
05982	191																											
05983	191																											
05984	191																											
05985	191																											
05986	191																											
05987	191																											
05988	188																											
05989	191																											
05990	193																											
05991	193																											
05992	193																											
05993	191																											
05995	189																											
05997	191																											
05998	191																											

Code	Pag	SIDE-HUNG CROSS-SECTIONS TYPE															PIVOTING CROSS-SECTIONS TYPE											
		C001	C002	C003	C004	C005	C006	C007	C008	C009	C010	C011	C012	C013	C014	C015	C016	C017	P001	P002	P003	P004	P005	P006	P007	P008	P009	P010
05999	188																											
06004	607																											
06005	609																											
06006	607																											
06007	609																											
06008	617																											
06009	619																											
06010	630																											
06011	630																											
06014	627																											
06015	619																											
0601801	615																											
06019	613																											
06037	611																											
0603801	615																											
06039	613																											
06040	669																											
06044	669																											
06045	669																											
06046	669																											
06047	669																											
06048	669																											
06052	611																											
06054	613																											
06112	669																											
06113	669																											
06168	36																											
06169	36																											
06170	36	■	■	■		■	■		■				■	■	■		■	■				■	■	■	■	■	■	■
06171	36	■	■	■	■	■		■					■	■	■		■	■				■	■	■	■	■	■	■
06172	36				■																							
06173	36																											
06174	36																											
06175	36																											
06176	36	■	■	■				■	■	■			■	■	■	■	■	■	■	■	■	■	■	■	■	■	■	■
06177	36	■	■	■				■	■	■			■	■	■	■	■	■	■	■	■	■	■	■	■	■	■	■
06178	36			■					■	■																	■	
06179	36									■																		
06180	36	■	■												■								■					
06181	36	■	■												■								■					
06195N	46	■	■																				■					
06196N	46	■	■																									
06231	669																											
06232	669																											
06233	669																											
06301	669																											
06302	669																											
06303	669																											
0630901	666																											
0631001	666																											
06311	669																											
06312	669																											
06313	669																											
06321	669																											
06322	669																											
06323	669																											
06324	672																											
06325	669																											

CODE / PROFILE CROSS-SECTIONS TYPE

Code	Pag	SIDE-HUNG CROSS-SECTIONS TYPE															PIVOTING CROSS-SECTIONS TYPE													
		C001	C002	C003	C004	C005	C006	C007	C008	C009	C010	C011	C012	C013	C014	C015	C016	C017	P001	P002	P003	P004	P005	P006	P007	P008	P009	P010		
06326	669																													
06327	672																													
06328	672																													
06329	672																													
06330	672																													
06332	669																													
06333	669																													
06334	660																													
06335	660																													
06336	660																													
06337	660																													
06338	660																													
06339	660																													
06340	660																													
06342	669																													
06343	669																													
06344	663																													
06345	663																													
06346	663																													
06347	663																													
06348	663																													
06349	663																													
06351	669																													
06352	669																													
06353	669																													
06354	663																													
06355	663																													
06356	663																													
06357	663																													
06358	663																													
06359	663																													
06360	672																													
06362	669																													
06364	663																													
06365	663																													
06366	663																													
06367	663																													
06368	663																													
06369	663																													
06370	663																													
06371	669																													
06372	669																													
06373	669																													
06374	663																													
06375	663																													
06381	670																													
06382	670																													
06383	670																													
06384	664																													
06385	664																													
06386	664																													
06387	664																													
06388	664																													
06389	664																													
06390	664																													
06391	670																													
06392	670																													
06393	670																													

CODE / PROFILE CROSS-SECTIONS TYPE

Code	Pag	SIDE-HUNG CROSS-SECTIONS TYPE															PIVOTING CROSS-SECTIONS TYPE											
		C001	C002	C003	C004	C005	C006	C007	C008	C009	C010	C011	C012	C013	C014	C015	C016	C017	P001	P002	P003	P004	P005	P006	P007	P008	P009	P010
06394	664																											
06395	664																											
06421	670																											
06422	670																											
06423	670																											
06431	670																											
06441	670																											
06443	670																											
06451	670																											
06452	670																											
06453	670																											
06461	670																											
06462	670																											
06463	670																											
06471	670																											
06472	670																											
06473	670																											
06481	670																											
06482	670																											
06483	670																											
06491	670																											
06492	670																											
06493	670																											
06500	324	■	■	■			■		■	■	■	■	■	■	■		■	■	■		■	■				■		
06501	324	■	■	■			■		■	■	■	■	■	■			■	■	■		■	■				■		
06502	324	■	■	■					■		■	■									■							
06503	597																											
06504	595																											
06510	325	■	■	■			■		■	■	■	■	■	■	■		■	■	■		■	■				■		
06512	597																											
06521	314																											
06523	314																											
06528	315																											
06529	315																											
06532	314																											
06533	314																											
06534	314																											
06535	314																											
06575	308																											
06579	315																											
06791	313																											
06792	670																											
06793	670																											
06951	444																											
06951	452																											
06954	603																											
06955	595																											
06980	119	■	■				■																					
06981	119	■	■				■																					
07000	140																											
07002	140																											
07003	140																											
07005	140																											
07006	140																											
07008	140																											
07009	140																											
07012	140																											
07057N	637																											

CODE / PROFILE CROSS-SECTIONS TYPE

Code	Pag	SIDE-HUNG CROSS-SECTIONS TYPE															PIVOTING CROSS-SECTIONS TYPE											
		C001	C002	C003	C004	C005	C006	C007	C008	C009	C010	C011	C012	C013	C014	C015	C016	C017	P001	P002	P003	P004	P005	P006	P007	P008	P009	P010
07058N	173	■	■										■			■												
0714102	648																											
0714202	648																											
07195	599																											
07196	600																											
07310	217																											
07312	220																											
07315	222																											
07315	232																											
07316	222																											
07316	232																											
07317	222																											
07317	232																											
07318	222																											
07318	232																											
0732201	225																											
0732201	235																											
07324	225																											
07324	235																											
0737201	646																											
07373	640																											
07374	640																											
0737801	646																											
07410	227								■																			
07411	227								■																			
07412	227								■																			
07413	228								■																			
07414	228								■																			
07415	228								■																			
07418	230								■																			
07420	227																											
07421	227																											
07422	227																											
07426	230																											
07427	230																											
07428	230																											
07430	245	■	■	■					■	■			■		■		■	■	■	■	■	■						
07431	245	■	■	■					■	■			■		■		■	■	■	■	■	■						
07470N	224																											
07470N	234																											
07471	224								■																			
07471	234								■																			
07472	234								■																			
07473	224																											
07473	234																											
07474	224																											
07474	234																											
07475	224																											
07475	234																											
0763001	180																											
0763101	180																											
0763201	180																											
07640	240			■									■															
07643	240	■	■						■												■							
07653	241	■	■						■												■							
07660	240	■	■	■									■				■	■			■							
07660	246	■	■	■									■				■	■			■							
07661	240																											

Code	Pag	SIDE-HUNG CROSS-SECTIONS TYPE															PIVOTING CROSS-SECTIONS TYPE										
		C001	C002	C003	C004	C005	C006	C007	C008	C009	C010	C011	C012	C013	C014	C015	C016	C017	P001	P002	P003	P004	P005	P006	P007	P008	P009
07661	246																										
07662	240	■	■					■	■			■						■	■								
07662	246	■	■					■	■			■						■	■								
07663	240	■	■												■							■					
07663	246	■	■												■							■					
07664	241	■	■	■								■					■	■			■						
07664	247	■	■	■								■					■	■			■						
07665	241																										
07665	247																										
07666	241	■	■					■	■			■						■	■								
07666	247	■	■					■	■			■						■	■								
07667	241	■	■												■							■					
07667	247	■	■												■							■					
07674	189																										
07675	188																										
07676	193																										
07678	191																										
07679	191																										
07680	188	■	■	■				■	■				■									■					
07681	188	■	■										■		■			■				■					
07682	188																										
07683	188	■	■							■			■						■								
07684	188	■	■																								
07685	188	■	■	■											■				■			■					
07686	189	■	■																								
07687	188	■	■										■														
07688	188																										
07689	188																										
07690	243	■	■										■		■			■	■			■					
07690	249	■	■										■		■			■	■			■					
07691	243	■	■	■									■	■				■	■			■					
07691	249	■	■	■									■	■				■	■			■					
07693	243							■	■																		
07693	249							■	■																		
07694	243																										
07694	249																										
07695	243																										
07695	249																										
07696	189																										
07697	188																										
07698	188																										
07699	188																										
07700	243	■	■										■		■			■	■			■					
07700	249	■	■										■		■			■	■			■					
07701	243	■	■	■											■												
07701	249	■	■	■											■												
07702	243																										
07702	249																										
07704	249																										
07830N	217							■																			
07831N	218							■																			
07832N	220							■																			
07833	238																										
07835N	222							■																			
07835N	232							■																			
07836N	222							■																			
07836N	232							■																			
07837N	222							■																			

CODE / PROFILE CROSS-SECTIONS TYPE

Code	Pag	SIDE-HUNG CROSS-SECTIONS TYPE															PIVOTING CROSS-SECTIONS TYPE											
		C001	C002	C003	C004	C005	C006	C007	C008	C009	C010	C011	C012	C013	C014	C015	C016	C017	P001	P002	P003	P004	P005	P006	P007	P008	P009	P010
07837N	232							■																				
07838N	222							■																				
07838N	232							■																				
07843	210	■	■	■	■			■							■	■	■		■			■	■		■			
07843	221	■	■	■	■			■							■	■	■		■			■	■		■			
07843	237	■	■	■	■			■							■	■	■		■			■	■		■			
07844	210	■	■	■	■			■							■	■	■		■			■	■		■			
07844	221	■	■	■	■			■							■	■	■		■			■	■		■			
07844	237	■	■	■	■			■							■	■	■		■			■	■		■			
07845	210	■	■	■	■			■							■	■	■		■			■	■		■			
07845	221	■	■	■	■			■							■	■	■		■			■	■		■			
07845	237	■	■	■	■			■							■	■	■		■			■	■		■			
07850	469	■	■	■			■	■	■	■	■		■	■	■		■	■	■	■	■	■	■	■	■	■	■	■
07851	469	■	■	■			■	■	■	■	■		■	■	■		■	■	■	■	■	■	■	■	■	■	■	■
07852	469	■	■	■			■	■	■	■	■		■	■	■		■	■	■	■	■	■	■	■	■	■	■	■
07853	469	■	■	■			■	■	■	■	■		■	■	■		■	■	■	■	■	■	■	■	■	■	■	■
08123	352				■																							
08124	352				■																							
08127N	337																											
08128N	337																											
08130N	337																											
08133N	337																											
0814701	339																											
0814901	339				■																							
0815101	339				■																							
0815201	339				■																							
08177	352				■																							
08178	352				■																							
08179	352				■																							
08183	352				■																							
08184	353				■																							
08185	353				■																							
08186	353				■																							
08187	353				■																							
08188	353				■																							
08189	353				■																							
08195	338																											
08196	338																											
08197	338																											
08198	338																											
08199	354																											
08200	354																											
08201	338																											
08202	338																											
08222	340																											
08223	340																											
08224	340																											
08225	340																											
08226	340																											
08232	341																											
08233	341																											
08234	341																											
08235	341																											
08236	341																											
08309	343	■	■																									
08341	346																											
08342	346																											
08343	346																											

Code	Pag	SIDE-HUNG CROSS-SECTIONS TYPE															PIVOTING CROSS-SECTIONS TYPE											
		C001	C002	C003	C004	C005	C006	C007	C008	C009	C010	C011	C012	C013	C014	C015	C016	C017	P001	P002	P003	P004	P005	P006	P007	P008	P009	P010
08348	343																											
08349	346	■	■										■			■		■									■	
08350	346	■	■										■			■		■									■	
08351	343	■	■										■			■		■									■	
08352	343	■	■										■			■		■									■	
08500	362																											
08534N	343				■																						■	
08535N	343				■																						■	
08536N	343				■																						■	
08537N	343				■																						■	
08538N	343				■																						■	
08539N	343				■																						■	
08540N	343				■																						■	
08541N	343				■																						■	
08542N	343				■																						■	
08886	344																											
08887	344																											
08888	344																											
08889	344																											
08890	344																											
08891	344																											
08892	344																											
08893	344																											
08894	344																											
89989	319																											
9002901	644																											
9003001	643																											
90032	644																											
9003301	643																											
9003401	644																											
90035	645																											
9003601	643																											
9003801	644																											
90039	643																											
90040	643																											
90041N	645																											
9004201	644																											
90043	645																											
90044N	643																											
90047	644																											
90049	640																											
90055	640																											
90056	640																											
90057	640																											
90058	640																											
90061	640																											
90062	640																											
90063	640																											
90064	640																											
90067	640																											
90068	640																											
90070	640																											
90075	640																											
9007601	646																											
90079	643																											
9008001	643																											
90081	640																											
90082	640																											

CODE / PROFILE CROSS-SECTIONS TYPE

Code	Pag	SIDE-HUNG CROSS-SECTIONS TYPE															PIVOTING CROSS-SECTIONS TYPE												
		C001	C002	C003	C004	C005	C006	C007	C008	C009	C010	C011	C012	C013	C014	C015	C016	C017	P001	P002	P003	P004	P005	P006	P007	P008	P009	P010	
90083	640																												
90084	640																												
90085	644																												
9008701	641																												
90088N	640																												

 **GIESSE**

**HINGES FOR
DOORS AND
WINDOWS**



FLASH BASE HINGES

Functions

Two-handed hinge for aluminium casement window and door fixtures with central gasket seal.

Online data sheet



Technical Features

Supplied preassembled to enable fast installation and faultless positioning of the hinge on already assembled fixtures.

Special fixing plates, preassembled with the hinge bodies (Giesse RAPID system), enable fast installation and faultless positioning of the hinge on already assembled fixtures.

The FLASH BASE hinge is fitted extremely quickly to the sash and frame, even when the fixture has already been assembled.

The particular geometry of the hinge and of the plate enables swift and simple application to the already assembled fixture, and faultless positioning of the hinge when fixing the screws.

Hinges 00120 00122 00123 00128 and 00259 are certified to EN1935:2002 and classified for windows typified by average intensity of use (use category 2* - average use) with high resistance to fatigue and wear (durability grade 7* - 200,000 test cycles).

* Complies with EN 1935

Materials

Extruded aluminium hinge bodies
Stainless steel pin, screws and fixing plates
Polyamide bushes

Capacities

With 2 FLASH BASE hinges: 75 kg
With 3 FLASH BASE hinges: 85 kg
assuming fixtures of 2000 mm height and 1000 mm width.

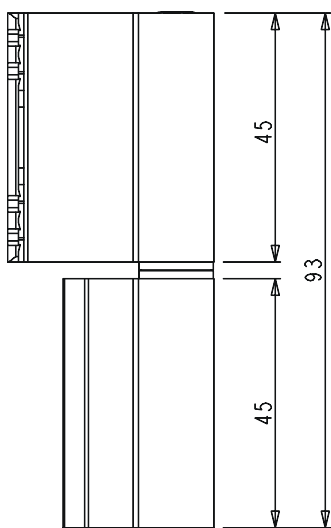

Side profile cross-section

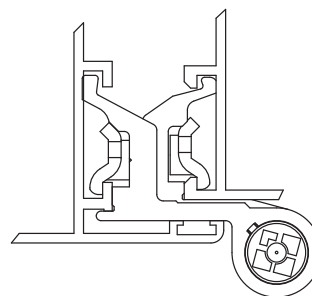

third sash cross-section

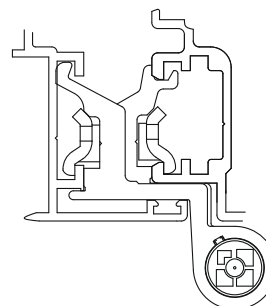

HINGES FOR WINDOWS

Item code	Description	PROFILE CROSS - SECTION	Pre-assembled	Hand	Flush opening	Third sash	Base Raw	Anodised Elox	Painted	Trend/Gold Brass	Pieces per pack
00094U	FLASH BASE HINGE	see Where Used					X		X	X	20
00095U	FLASH BASE HINGE	see Where Used					X	X	X	X	20
00099U	FLASH BASE HINGE	see Where Used					X	X	X	X	20
00100U	FLASH BASE HINGE	see Where Used					X	X	X		20
001201	FLASH BASE HINGE	C001	X	RX				X	X	X	50
001202	FLASH BASE HINGE	C001	X	LX				X	X	X	50
00120U	FLASH BASE HINGE	C001					X	X	X	X	20
001211	FLASH BASE HINGE	see Where Used	X	RX		X		X	X	X	50
001212	FLASH BASE HINGE	see Where Used	X	LX		X		X	X	X	50
00121U	FLASH BASE HINGE	see Where Used				X	X	X	X	X	20
001221	FLASH BASE HINGE	C002	X	RX				X	X	X	50
001222	FLASH BASE HINGE	C002	X	LX				X	X	X	50
00122U	FLASH BASE HINGE	C002					X	X	X	X	20
001231	FLASH BASE HINGE	see Where Used	X	RX		X		X	X	X	50
001232	FLASH BASE HINGE	see Where Used	X	LX		X		X	X	X	50
00123U	FLASH BASE HINGE	see Where Used				X	X	X	X	X	20
00126U	FLASH BASE HINGE	C008					X	X	X	X	20
00127U	FLASH BASE HINGE	C008				X	X	X	X	X	20
001281	FLASH BASE HINGE	C007	X	RX				X	X	X	50
001282	FLASH BASE HINGE	C007	X	LX				X	X	X	50
00128U	FLASH BASE HINGE	C007					X	X	X	X	20
00129U	FLASH BASE HINGE	C007				X	X	X	X	X	20
00130U	FLASH BASE HINGE	C005					X	X	X	X	20
001341	FLASH BASE HINGE	C009	X	RX				X	X	X	50
001342	FLASH BASE HINGE	C009	X	LX				X	X	X	50
00134U	FLASH BASE HINGE	C009					X	X	X	X	20
00135U	FLASH BASE HINGE	see Where Used				X	X	X	X	X	20
00136U	FLASH BASE HINGE	C003					X	X	X	X	20
00137U	FLASH BASE HINGE	see Where Used					X	X	X	X	20
00142U	FLASH BASE HINGE	see Where Used					X	X	X		20
001431	FLASH BASE HINGE	C015	X	RX		X		X	X	X	50
001432	FLASH BASE HINGE	C015	X	LX		X		X	X	X	50
00143U	FLASH BASE HINGE	C015				X	X	X	X	X	20
0014411	FLASH BASE HINGE	C001-C002-C013-C014-C015-C016-C017	X	RX		X		X	X		50
0014421	FLASH BASE HINGE	C001-C002-C013-C014-C015-C016-C017	X	LX		X		X	X		50
00144N	FLASH BASE HINGE	C001-C002-C013-C014-C015-C016-C017				X	X	X	X	X	20
00147N	FLASH BASE HINGE	C003					X	X	X		20
00227U	FLASH BASE HINGE	see Where Used						X	X		20
00240U	FLASH BASE HINGE	C011					X	X	X	X	20
00258U	FLASH BASE HINGE	see Where Used						X	X	X	20
002591	FLASH BASE HINGE	C010	X	RX		X		X	X	X	50
002592	FLASH BASE HINGE	C010	X	LX		X		X	X	X	50
00259U	FLASH BASE HINGE	C010				X	X	X	X	X	20
002701	FLASH BASE HINGE	see Where Used	X	RX			X	X	X	X	50
002702	FLASH BASE HINGE	see Where Used	X	LX			X	X	X	X	50
00278U	FLASH BASE HINGE	see Where Used			X		X	X	X	X	20
00279U	FLASH BASE HINGE	see Where Used				X	X	X	X	X	20
002811	FLASH BASE HINGE	see Where Used				X			X		50
002812	FLASH BASE HINGE	see Where Used				X			X		50
00281U	FLASH BASE HINGE	see Where Used				X	X	X	X	X	20

HINGES FOR WINDOWS

Item code	Description	PROFILE CROSS - SECTION	Pre-assembled	Hand	Flush opening	Third sash	Base Raw	Anodised Elox	Painted	Trend/Gold Brass	Pieces per pack
002851	FLASH BASE HINGE	see Where Used	X	RX				X	X		50
002852	FLASH BASE HINGE	see Where Used	X	LX				X	X		50
00285U	FLASH BASE HINGE	see Where Used					X	X	X	X	20
005271	FLASH BASE HINGE	C001-C005	X	RX				X	X	X	50
005272	FLASH BASE HINGE	C001-C005	X	LX				X	X	X	50
00527U	FLASH BASE HINGE	C001-C005					X		X		20
00529U	FLASH BASE HINGE	see Where Used				X	X	X	X	X	20
005641	FLASH BASE HINGE	see Where Used	X	RX	X			X	X		50
005642	FLASH BASE HINGE	see Where Used	X	LX	X			X	X		50
00564U	FLASH BASE HINGE	see Where Used			X			X	X	X	20
00612U	FLASH BASE HINGE	see Where Used					X	X	X	X	20

Note: For the «Third sash» hinges, check the correct series on Where-used.



FLASH BASE 3-WING HINGE

Functions

Two-handed 3-wing hinge, for lightweight window and door fixtures made with channel profile.

Online data sheet



Technical Features

Two-handed three wing hinge, suitable for lightweight door fixtures and bottom hung or projecting type windows. Special fixing plates, preassembled with the hinge bodies (Giesse RAPID system), enable fast installation and faultless positioning of the hinge on already assembled fixtures.

Materials

Extruded aluminium hinge bodies
Pin, fixing plates, screws and grub screw, all stainless steel
Acetal resin bushes

Capacities

85 kg with 2 hinges
100 kg with 3 hinges

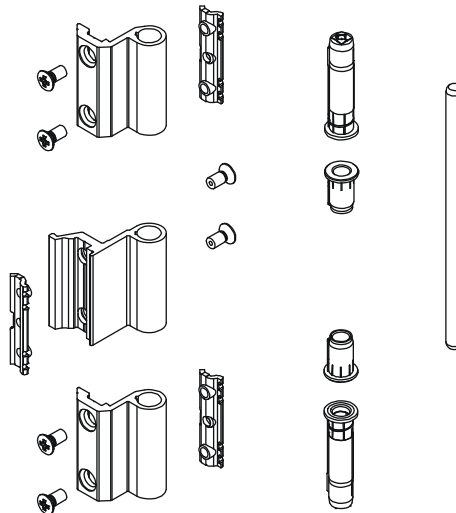
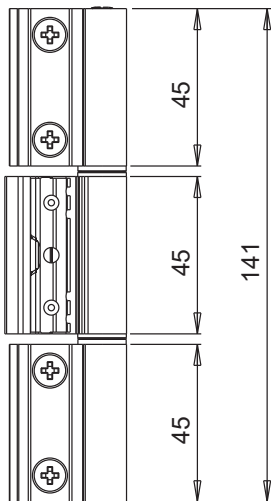

Item code	Description	PROFILE CROSS - SECTION	Load capacity 2 hinges [kg]	Load capacity 3 hinges [kg]	Base Raw	Anodised Elox	Painted	Trend/Gold Brass	Pieces per pack
00103U	FLASH BASE 3-WING HINGE	C003	85	100	X				20
00115U	FLASH BASE 3-WING HINGE	C001	85	100	X	X	X		20
00119	FLASH BASE 3-WING HINGE	C001-C002-C013-C014-C015-C016-C017	85	100	X		X		20
00171	FLASH BASE 3-WING HINGE	see Where Used	85	100	X		X		20

FLASH HINGES



Functions

Two-handed adjustable hinge for aluminium casement window and door fixtures with central gasket seal.

Online data sheet



Technical Features

Supplied preassembled to enable fast installation and faultless positioning of the hinge on already assembled fixtures.

The burglar-proof pin, made of forged stainless steel, features a collar mid-way along its length that prevents any forcible attempt at removal.

Special fixing plates, preassembled with the hinge bodies (Giesse RAPID system), enable fast installation and faultless positioning of the hinge on already assembled fixtures.

The FLASH hinge is fitted extremely quickly to the sash and frame, even when the fixture has already been assembled.

The particular geometry of the hinge and of the plate enables swift and simple application to the already assembled fixture, and faultless positioning of the hinge when fixing the screws.

Adjustments

The hinge features an eccentric pin which, when adjusted by rotation in the respective bush, provides a compression and distance adjustment of ± 0.3 mm.

Materials

Extruded aluminium hinge bodies
Stainless steel pin, screws and fixing plates
Polyamide bushes

Capacities

With 2 FLASH BASE hinges: 75 kg
With 3 FLASH BASE hinges: 85 kg
assuming fixtures of 2000 mm height and 1000 mm width.

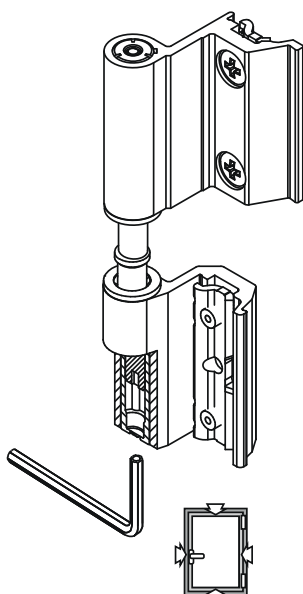
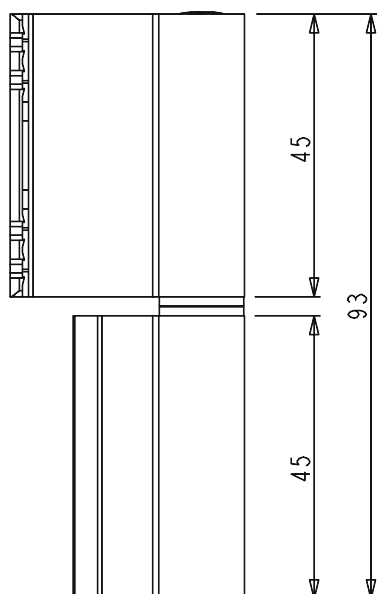

Side profile cross-section

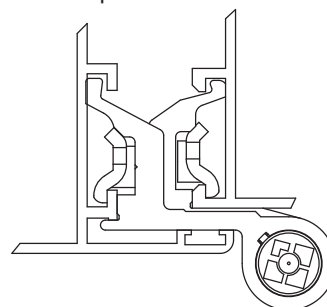

third sash cross-section

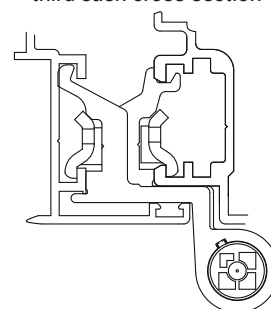

HINGES FOR WINDOWS

Item code	Description	PROFILE CROSS - SECTION	Third sash	Base Raw	Anodised Elox	Painted	Trend/Gold Brass	Pieces per pack
00149U	FLASH HINGE	see Where Used		X	X	X	X	20
00150U	FLASH HINGE	C001		X	X	X	X	20
00151U	FLASH HINGE	see Where Used	X	X	X	X	X	20
00157U	FLASH HINGE	C008	X	X		X	X	20

Note: For the «Third sash» hinges, check the correct series on Where-used.

SASH HINGE SET FOR CHIC 3D 100

Functions

Set of hinges (top and bottom) for side-hung or secondary sash with tilt-and-turn CHIC 3D 100.

Online data sheet

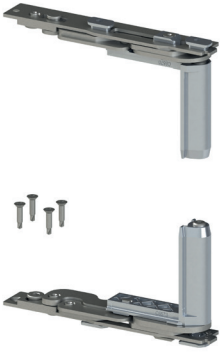

Technical Features

Sash opening to 180°.
 Maximum load capacity 100 kg.
 Assembly is simple, fast and easy using the special pre-assembled cams.
 When there is an additional fastening mechanism, you need to use the CHIC fastening element.
 Both hinges are adjustable (3D).
 If opening is obstructed, you need to use the FRIZ limitation arm.
CAUTION: This hinge is designed to be used only on inward opening casements and is not suitable for outward opening casements.

Materials

Corner support made of zamak
 Connecting brackets and hinge plates made of zinc plated steel
 Pins made of 304 grade stainless steel and aluminium bronze
 Cams made of zinc plated steel

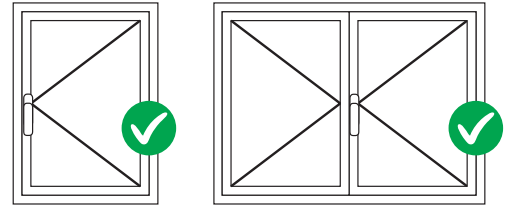

ADJUSTMENTS [mm]

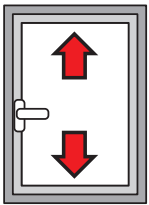

Height:
+2.5 / -1

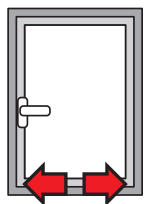

Side:
+1.5 / -1.5

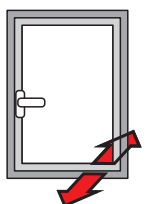

Hinge compression:
+1.4 / -0.6

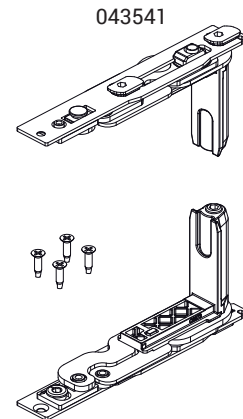
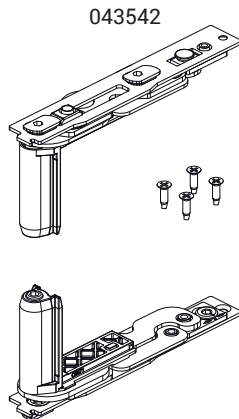

Adjustments

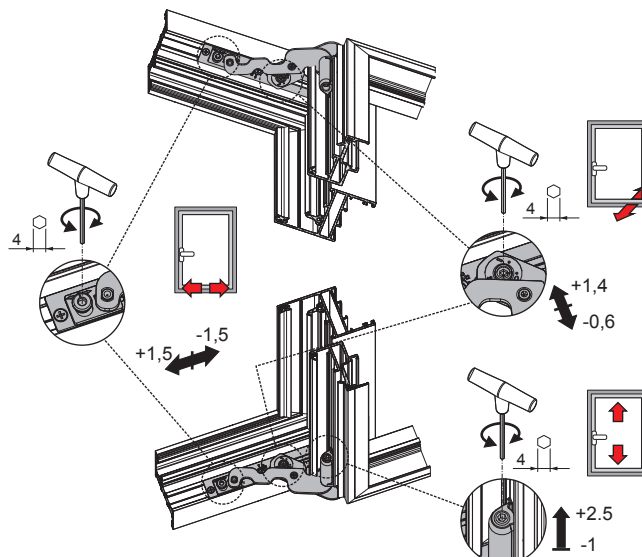

Table of maximum glass thickness [mm]

2500	33	27	23	20	18	16	15	14	13	12	11	
2400	33	27	23	20	18	16	15	14	13	12	11	
2300	34	28	24	21	19	17	16	14	13	12	11	
2200	36	30	25	22	20	18	16	15	14	13	12	
2100	37	31	27	23	21	19	17	16	14	13	12	
2000	39	33	28	25	22	20	18	16	15	14	13	
1900	41	34	30	26	23	21	19	17	16	15	14	
1800	44	36	31	27	24	22	20	18	17	16	15	
1700	46	38	33	29	26	23	21	19	18	16	15	
1600	49	41	35	31	27	25	22	20	19	17	15	
1500	50	44	37	33	29	26	24	22	20	17	15	
1400	50	47	40	35	31	28	25	23	20	17	15	
1300	50	50	43	38	34	30	27	24	20	17	15	
1200	50	50	47	41	36	33	28	24	20	17	15	
1100	50	50	50	45	40	34	28	24	20	17		
1000	50	50	50	49	42	34	28	24	20			
900	50	50	50	50	42	34	28	24				
800	50	50	50	50	42	34	28					
700	50	50	50	50	42	34						
600	160	500	600	700	800	900	1000	1100	1200	1300	1400	1500

Table of maximum load capacity [kg]

2500	100	100	100	100	100	100	100	100	100	100	100	
2400	100	100	100	100	100	100	100	100	100	100	100	
2300	100	100	100	100	100	100	100	100	100	100	100	
2200	100	100	100	100	100	100	100	100	100	100	100	
2100	100	100	100	100	100	100	100	100	100	100	100	
2000	100	100	100	100	100	100	100	100	100	100	100	
1900	100	100	100	100	100	100	100	100	100	100	100	
1800	100	100	100	100	100	100	100	100	100	100	100	
1700	100	100	100	100	100	100	100	100	100	100	98	
1600	100	100	100	100	100	100	100	100	100	99	92	
1500	100	100	100	100	100	100	100	100	100	93	87	
1400	100	100	100	100	100	100	100	100	93	87	81	
1300	100	100	100	100	100	100	100	94	87	80	75	
1200	100	100	100	100	100	100	95	87	80	74	69	
1100	100	100	100	100	100	95	87	79	73	68		
1000	100	100	100	100	96	87	79	72	67			
900	100	100	100	98	87	78	71	65				
800	100	100	99	87	77	69	63					
700	100	100	87	76	67	61						
600	160	500	600	700	800	900	1000	1100	1200	1300	1400	1500

Mandatory to use the FRIZ arm

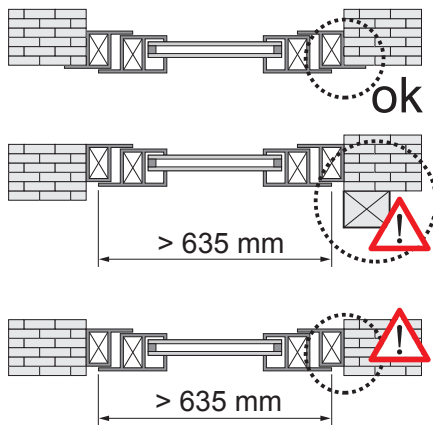

FRIZ arm positioning

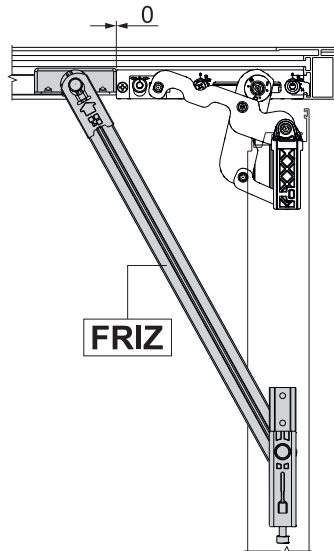

Opening angle with FRIZ arm

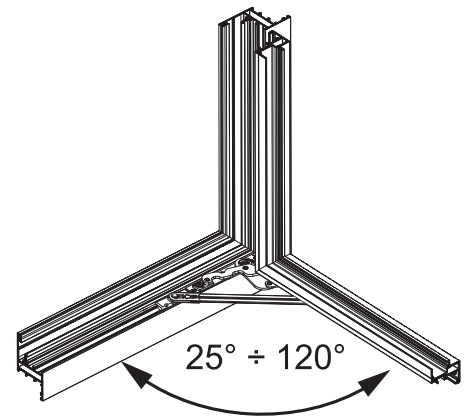

Item code	Description	PROFILE CROSS - SECTION	Hand	Base Raw	Anodised Elox	Painted	Trend/Gold Brass	Pieces per pack
043541	CHIC - SASH HINGE SET	C001-C002-C003-C005-C006	RX	X				10
043542	CHIC - SASH HINGE SET	C001-C002-C003-C005-C006	LX	X				10

FLUSH CHIC 3D 100 SASH HINGE KIT



Functions

CHIC 3D 100 FLUSH hinge set (top and bottom) for side-hung sash or secondary sash combined with turn-and-tilt sash.

Online data sheet



Technical Features

Sash opening to 105°. Maximum load capacity 100 kg. Assembly is simple, fast and easy using the special pre-assembled cams. When there is an additional fastening mechanism, you need to use the CHIC fastening element. Both hinges are adjustable (3D). It is mandatory to use the CHIC limitation arm (code 05293). **CAUTION:** This hinge is designed to be used only on inward opening casements and is not suitable for outward opening casements.

Materials

Corner support made of zamak
Connecting brackets and hinge plates made of zinc plated steel
Pins made of 304 grade stainless steel and aluminium bronze
Cams made of zinc plated steel

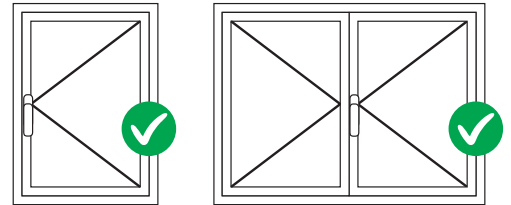

ADJUSTMENTS [mm]

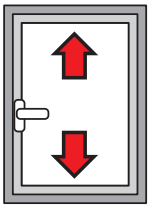

Height:
+2.5 / -1

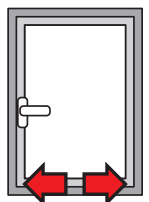

Side:
+1.5 / -1.5

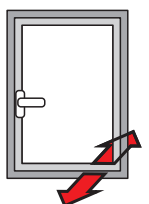

Hinge compression:
+1.4 / -0.6

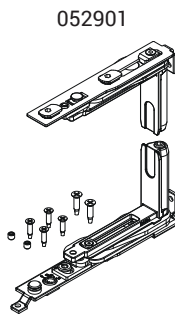
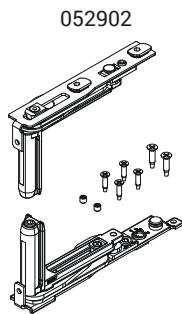

Adjustments

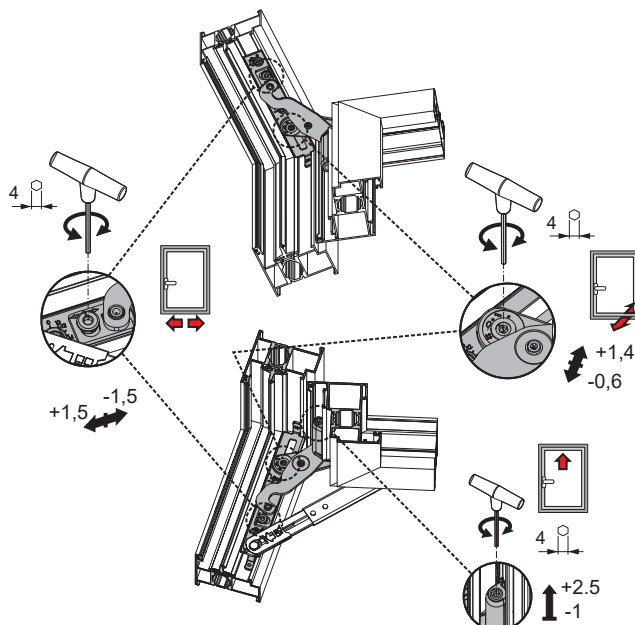

Table of maximum glass thickness [mm]

3000																				
2900	27	22	19	16	15	13	12	11												
2800	27	23	19	17	15	14	12	11												
2700	28	23	20	18	16	14	13	12	11											
2600	29	24	21	18	16	15	13	12	11											
2500	30	25	22	19	17	15	14	13	12	11										
2400	33	27	23	20	18	16	15	14	13	12										
2300	33	27	23	20	18	16	15	14	13	12	11									
2200	34	28	24	21	19	17	16	14	13	12	11									
2100	36	30	25	22	20	18	16	15	14	13	12									
2000	37	31	27	23	21	19	17	16	14	13	12									
1900	39	33	28	25	22	20	18	16	15	14	13									
1800	41	34	30	26	23	21	19	17	16	15	14									
1700	44	36	31	27	24	22	20	18	17	16	15									
1600	46	38	33	29	26	23	21	19	18	16	15									
1500	49	41	35	31	27	25	22	20	19	17	15									
1400	50	44	37	33	29	26	24	22	20	17	15									
1300	50	47	40	35	31	28	25	23	20	17	15									
1200	50	50	43	38	34	30	27	24	20	17	15									
1100	50	50	47	41	36	33	28	24	20	17	15									
1000	50	50	50	45	40	34	28	24	20	17										
900	50	50	50	49	42	34	28	24	20											
800	50	50	50	50	42	34	28													
700	50	50	50	50	42	34														
600	50	50	50	50	42	34														
	420	500	600	700	800	900	1000	1100	1200	1300	1400	1500								

Table of maximum load capacity [kg]

3000																				
2900	100	100	100	100	100	100	100	100												
2800	100	100	100	100	100	100	100	100												
2700	100	100	100	100	100	100	100	100	100											
2600	100	100	100	100	100	100	100	100	100	100										
2500	100	100	100	100	100	100	100	100	100	100	100									
2400	100	100	100	100	100	100	100	100	100	100	100	100								
2300	100	100	100	100	100	100	100	100	100	100	100	100	100							
2200	100	100	100	100	100	100	100	100	100	100	100	100	100	100						
2100	100	100	100	100	100	100	100	100	100	100	100	100	100	100	100					
2000	100	100	100	100	100	100	100	100	100	100	100	100	100	100	100	100				
1900	100	100	100	100	100	100	100	100	100	100	100	100	100	100	100	100				
1800	100	100	100	100	100	100	100	100	100	100	100	100	100	100	100	100				
1700	100	100	100	100	100	100	100	100	100	100	100	100	100	100	100	100				
1600	100	100	100	100	100	100	100	100	100	100	100	100	100	100	100	100	100			
1500	100	100	100	100	100	100	100	100	100	100	100	100	100	100	100	100	99	92		
1400	100	100	100	100	100	100	100	100	100	100	100	100	100	100	100	100	93	87		
1300	100	100	100	100	100	100	100	100	100	100	100	100	100	100	100	93	87	81		
1200	100	100	100	100	100	100	100	100	100	100	94	87	80	75						
1100	100	100	100	100	100	100	100	100	100	95	87	80	74	69						
1000	100	100	100	100	100	100	95	87	79	73	68									
900	100	100	100	100	100	96	87	79	72	67										
800	100	100	100	98	87	78	71	65												
700	100	100	99	87	77	69	63													
600	100	100	87	76	67	61														
	420	500	600	700	800	900	1000	1100	1200	1300	1400	1500								

CHIC limitation arm(05293)

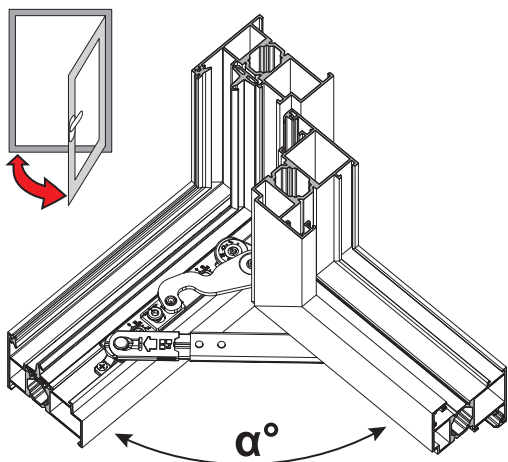

d (mm)	α°
102	105°
127	90°
>127	<90°
α° MAX 105	

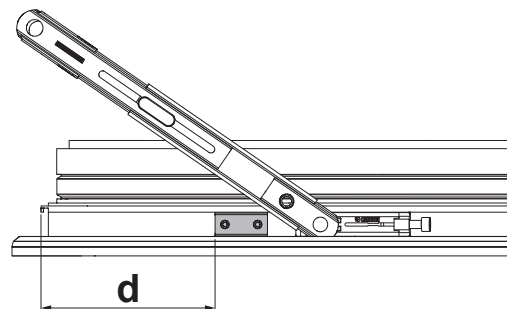

Item code	Description	PROFILE CROSS - SECTION	Hand	Base Raw	Anodised Elox	Painted	Trend/Gold Brass	Pieces per pack
052901	CHIC 100 FLUSH - SASH HINGE KIT	C013-C014-C015-C016-017	RX					10
052902	CHIC 100 FLUSH - SASH HINGE KIT	C013-C014-C015-C016-017	LX					10

Item code	Description	Interface type	Base Raw	Anodised Elox	Painted	Trend/Gold Brass	Pieces per pack
05293	CHIC - LIMITATION ARM	C013-C014-C015-C016-C017	X				10

HINGES FOR WINDOWS

SASH HINGE SET FOR CHIC 3D 130



Functions

Set of hinges (top and bottom) for side-hung or secondary sash with tilt-and-turn CHIC 3D 130.

Online data sheet



Technical Features

Sash opening to 180°. Maximum load capacity 130 kg. Assembly is simple, fast and easy using the special pre-assembled cams. When there is an additional fastening mechanism, you need to use the CHIC fastening element. Both hinges are adjustable (3D). If opening is obstructed, you need to use the FRIZ limitation arm. **CAUTION:** This hinge is designed to be used only on inward opening casements and is not suitable for outward opening casements.

Materials

Corner support made of zamak
Connecting brackets and hinge plates made of zinc plated steel
Pins made of 304 grade stainless steel and aluminium bronze
Cams made of zinc plated steel

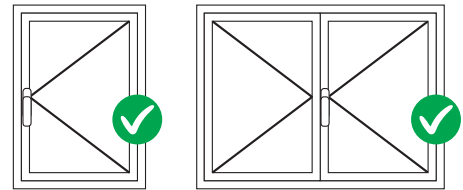

ADJUSTMENTS [mm]

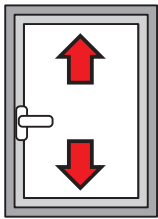

Height:
+2.5 / -1

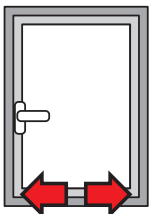

Side:
+1.5 / -1.5

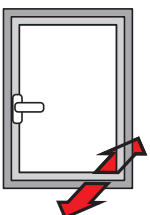

Hinge compression:
+1.4 / -0.6

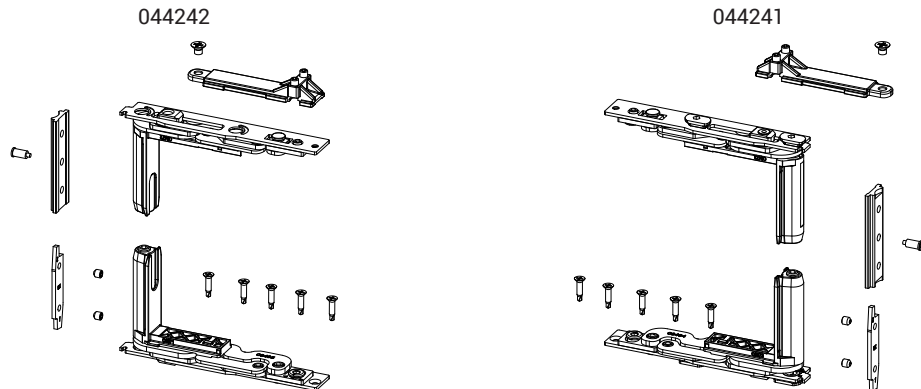

Adjustments

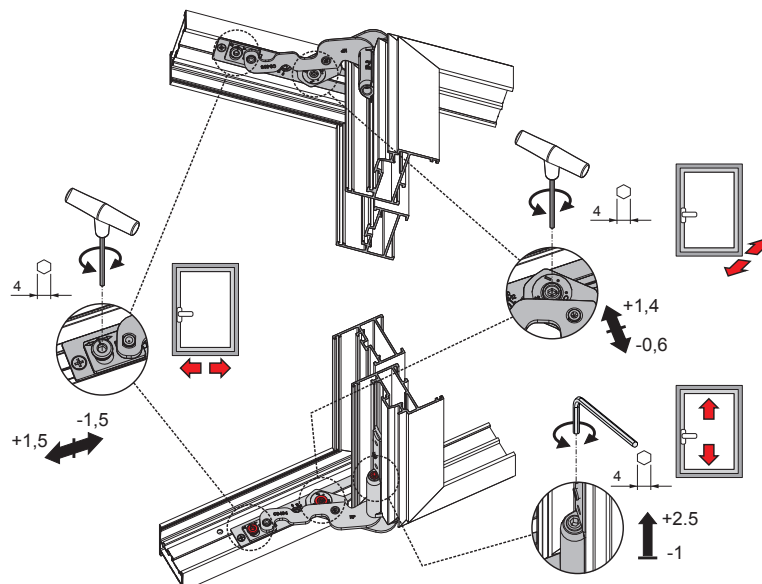

Table of maximum glass thickness [mm]

2800	35	29	25	22	19	17	16	14	13	12	12		
2700	37	31	26	23	20	18	17	15	14	13	12		
2600	39	32	28	24	21	19	18	16	15	14	13	12	
2500	43	35	30	27	24	21	19	18	16	15	14	13	
2400	43	35	30	27	24	21	19	18	16	15	14	13	
2300	44	37	32	28	25	22	20	18	17	16	15	14	
2200	46	39	33	29	26	23	21	19	18	17	15	14	
2100	49	40	35	30	27	24	22	20	19	17	16	15	
2000	51	43	36	32	28	26	23	21	20	18	17	16	
1900	54	45	38	34	30	27	24	22	21	19	18	17	
1800	57	47	40	35	31	28	26	24	22	20	19	18	
1700	60	50	43	38	33	30	27	25	23	21	20	18	
1600	60	53	46	40	35	32	29	27	25	23	21	18	
1500	60	57	49	43	38	34	31	28	26	24	21	18	
1400	60	60	52	46	40	36	33	30	28	24	21	18	
1300	60	60	56	49	44	39	36	33	28	24	21	18	
1200	60	60	60	53	47	43	39	33	28	24	21		
1100	60	60	60	58	52	46	39	33	28	24			
1000	60	60	60	60	57	47	39	33	28				
900	60	60	60	60	58	47	39	33					
800	60	60	60	60	58	47	39						
700	60	60	60	60	58	47							
600	200	500	600	700	800	900	1000	1100	1200	1300	1400	1500	1600

Table of maximum load capacity [kg]

2800	124	124	124	124	124	124	124	124	124	124	124	124	124	124	
2700	126	126	126	126	126	126	126	126	126	126	126	126	126	126	
2600	128	128	128	128	128	128	128	128	128	128	128	128	128	128	
2500	130	130	130	130	130	130	130	130	130	130	130	130	130	130	130
2400	130	130	130	130	130	130	130	130	130	130	130	130	130	130	130
2300	130	130	130	130	130	130	130	130	130	130	130	130	130	130	130
2200	130	130	130	130	130	130	130	130	130	130	130	130	130	130	130
2100	130	130	130	130	130	130	130	130	130	130	130	130	130	130	130
2000	130	130	130	130	130	130	130	130	130	130	130	130	130	130	130
1900	130	130	130	130	130	130	130	130	130	130	130	130	130	130	130
1800	130	130	130	130	130	130	130	130	130	130	130	130	130	130	130
1700	130	130	130	130	130	130	130	130	130	130	130	130	130	130	127
1600	130	130	130	130	130	130	130	130	130	130	130	130	130	127	119
1500	130	130	130	130	130	130	130	130	130	130	130	130	128	119	112
1400	130	130	130	130	130	130	130	130	130	130	130	129	119	111	104
1300	130	130	130	130	130	130	130	130	130	130	129	119	111	103	97
1200	130	130	130	130	130	130	130	130	130	119	110	102	95		
1100	130	130	130	130	130	130	130	130	119	109	101	94			
1000	130	130	130	130	130	130	119	108	99	92					
900	130	130	130	130	119	107	98	90							
800	130	130	130	119	106	95	87								
700	130	130	119	104	93	84									
600	200	500	600	700	800	900	1000	1100	1200	1300	1400	1500	1600		

Mandatory to use the FRIZ arm

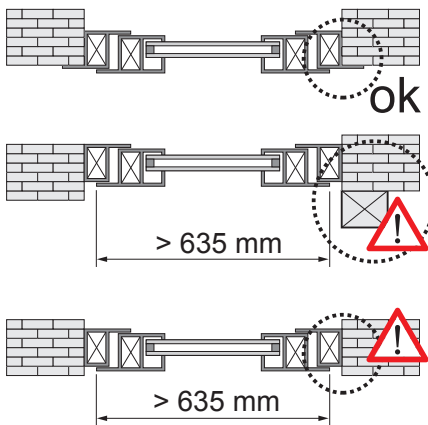

FRIZ arm positioning

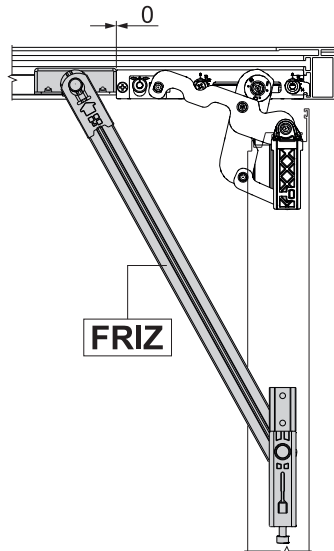

Opening angle with FRIZ arm

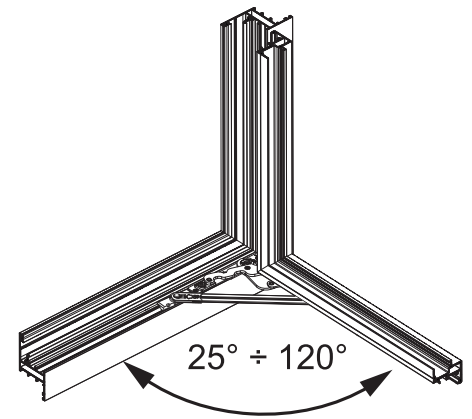

Item code	Description	PROFILE CROSS - SECTION	Hand	Base Raw	Anodised Elox	Painted	Trend/Gold Brass	Pieces per pack
044241	CHIC - SASH HINGE SET	C001	RX	X				10
044242	CHIC - SASH HINGE SET	C001	LX	X				10

CHIC 3D 150 SASH HINGE SET

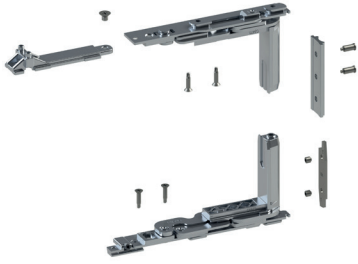

Functions

Set of hinges (top and bottom) for side-hung or secondary sash with tilt-and-turn CHIC 3D 150.

Online data sheet



Technical Features

Sash opening to 180°. Maximum load capacity 150 kg. Available in right- and left-hand versions. Assembly is simple, fast and easy using the special pre-assembled cams. When there is an additional fastening mechanism, you need to use the CHIC fastening element. Both hinges are adjustable (3D). If opening is obstructed, you need to use the FRIZ limitation arm. **CAUTION:** This hinge is designed to be used only on inward opening casements and is not suitable for outward opening casements.

Materials

Corner support made of zamak
Connecting brackets and hinge plates made of zinc plated steel
Pins made of 304 grade stainless steel and aluminium bronze
Cams made of zinc plated steel

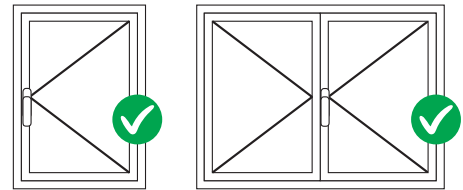

ADJUSTMENTS [mm]

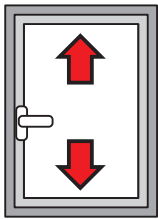

Height:
+2.5 / -1

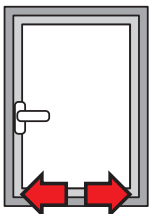

Side:
+1.5 / -1.5

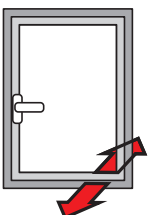

Hinge compression:
+1.4 / -0.6

0436421

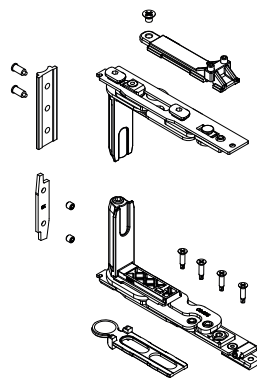

0436411

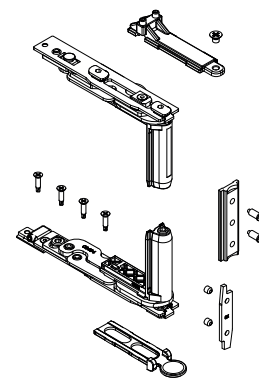

Adjustments

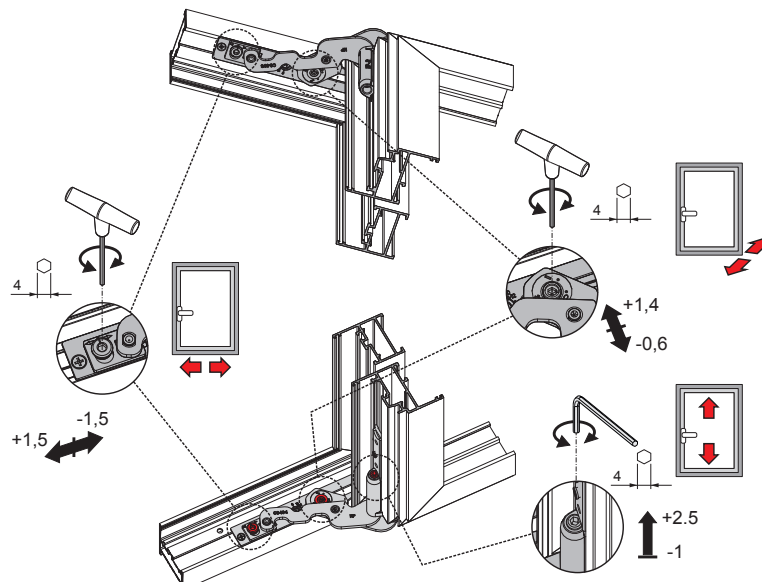

Table of maximum glass thickness [mm]

2800	40	33	29	25	22	20	18	17	15	14			
2700	42	35	30	26	23	21	19	18	16	15			
2600	45	37	32	28	25	22	20	19	17	16	15		
2500	49	41	35	31	27	25	22	20	19	18	16	15	
2400	49	41	35	31	27	25	22	20	19	18	16	15	
2300	51	43	37	32	28	26	23	21	20	18	17	16	
2200	54	45	38	33	30	27	24	22	21	19	18	17	
2100	56	47	40	35	31	28	25	23	22	20	19	18	
2000	59	49	42	37	33	29	27	25	23	21	20	18	
1900	60	52	44	39	34	31	28	26	24	22	21	19	
1800	60	55	47	41	36	33	30	27	25	23	22	20	
1700	60	58	49	43	38	35	31	29	27	25	23	20	
1600	60	60	53	46	41	37	33	31	28	26	23	20	
1500	60	60	56	49	44	39	36	33	30	26	23	20	
1400	60	60	60	53	47	42	38	35	30	26	23	20	
1300	60	60	60	57	50	45	41	35	30	26	23	20	
1200	60	60	60	60	55	49	42	35	30	26	23		
1100	60	60	60	60	59	51	42	35	30	26			
1000	60	60	60	60	60	51	42	35	30				
900	60	60	60	60	60	51	42	35					
800	60	60	60	60	60	51	42						
700	60	60	60	60	60	51							
600	470	500	600	700	800	900	1000	1100	1200	1300	1400	1500	1600

Table of maximum load capacity [kg]

2800	143	143	143	143	143	143	143	143	143	143			
2700	145	145	145	145	145	145	145	145	145	145			
2600	148	148	148	148	148	148	148	148	148	148	148		
2500	150	150	150	150	150	150	150	150	150	150	150	150	
2400	150	150	150	150	150	150	150	150	150	150	150	150	
2300	150	150	150	150	150	150	150	150	150	150	150	150	
2200	150	150	150	150	150	150	150	150	150	150	150	150	
2100	150	150	150	150	150	150	150	150	150	150	150	150	
2000	150	150	150	150	150	150	150	150	150	150	150	150	
1900	150	150	150	150	150	150	150	150	150	150	150	150	
1800	150	150	150	150	150	150	150	150	150	150	150	146	
1700	150	150	150	150	150	150	150	150	150	150	147	138	
1600	150	150	150	150	150	150	150	150	150	150	148	138	130
1500	150	150	150	150	150	150	150	150	150	150	139	130	122
1400	150	150	150	150	150	150	150	150	150	140	130	121	113
1300	150	150	150	150	150	150	150	150	140	130	120	112	105
1200	150	150	150	150	150	150	150	141	130	120	111	104	
1100	150	150	150	150	150	150	143	130	119	110	102		
1000	150	150	150	150	144	130	118	108	100				
900	150	150	150	146	130	117	106	97					
800	150	150	148	130	115	104	94						
700	150	150	130	113	101	91							
600	470	500	600	700	800	900	1000	1100	1200	1300	1400	1500	1600

Mandatory to use the FRIZ arm

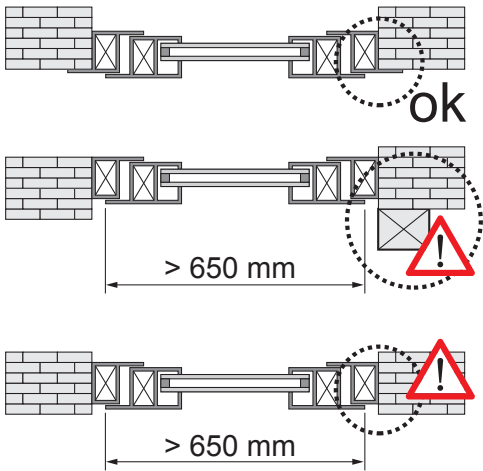

FRIZ arm positioning

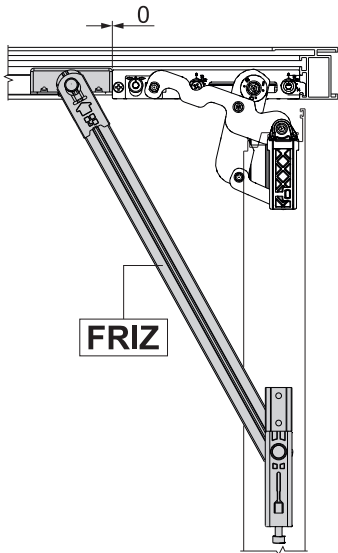

Opening angle with FRIZ arm

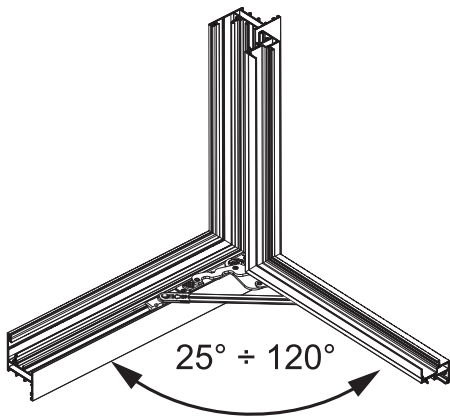

Item code	Description	PROFILE CROSS - SECTION	Hand	Base Raw	Anodised Elox	Painted	Trend/Gold Brass	Pieces per pack
0436411	CHIC - SASH HINGE SET	C001-C002-C003-C004-C005-C006	RX	X				10
0436421	CHIC - SASH HINGE SET	C001-C002-C003-C004-C005-C006	LX	X				10

SASH HINGE SET FOR CHIC 3D 130 ERRE

Functions

Set of hinges (top and bottom) for side-hung or secondary sash with tilt-and-turn CHIC 3D 130 ERRE.

Online data sheet



Technical Features

Sash opening to 180°. Maximum load capacity 130 kg. Assembly is simple, fast and easy using the special pre-assembled cams. Both hinges are adjustable (3D). If opening is obstructed, you need to use the FRIZ limitation arm.
CAUTION: This hinge is designed to be used only on inward opening casements and is not suitable for outward opening casements.

Materials

Corner support made of zamak
 Connecting brackets and hinge plates made of zinc plated steel
 Pins made of 304 grade stainless steel and aluminium bronze
 Cams made of zinc plated steel

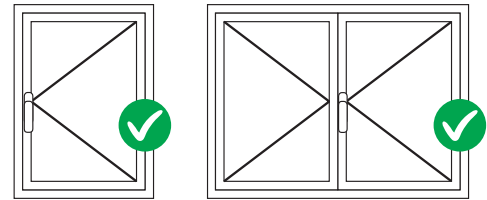

ADJUSTMENTS [mm]

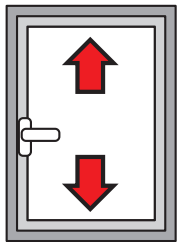

Height:
+2.5 / -1

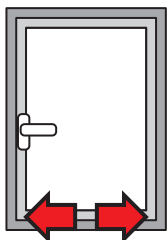

Side:
+1.5 / -1.5

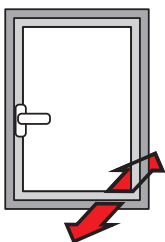

Hinge compression:
+1.4 / -0.6

052832

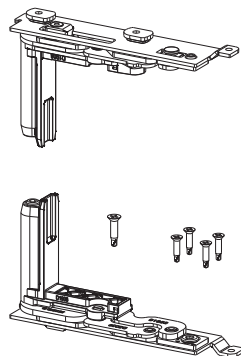

052831

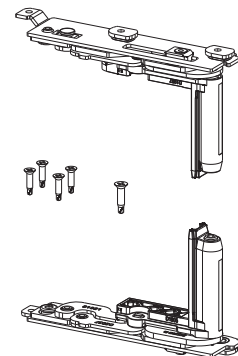

Adjustments

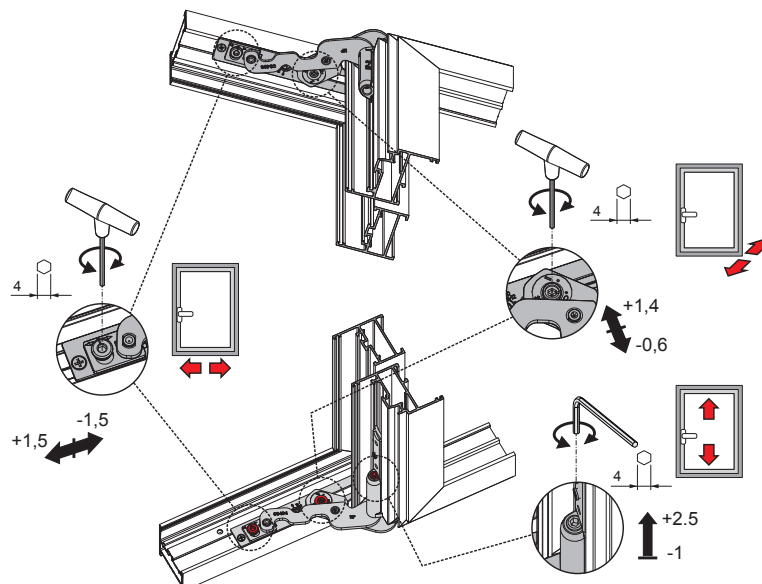

Table of maximum load capacity [kg]

Table of maximum glass thickness [mm]

2800	124	124	124	124	124	124	124	124	124	124	124		
2700	126	126	126	126	126	126	126	126	126	126	126		
2600	128	128	128	128	128	128	128	128	128	128	128		
2500	130	130	130	130	130	130	130	130	130	130	130		
2400	130	130	130	130	130	130	130	130	130	130	130		
2300	130	130	130	130	130	130	130	130	130	130	130		
2200	130	130	130	130	130	130	130	130	130	130	130		
2100	130	130	130	130	130	130	130	130	130	130	130		
2000	130	130	130	130	130	130	130	130	130	130	130		
1900	130	130	130	130	130	130	130	130	130	130	130		
1800	130	130	130	130	130	130	130	130	130	130	130		
1700	130	130	130	130	130	130	130	130	130	130	127		
1600	130	130	130	130	130	130	130	130	130	127	119		
1500	130	130	130	130	130	130	130	130	128	119	112		
1400	130	130	130	130	130	130	130	129	119	111	104		
1300	130	130	130	130	130	130	129	119	111	103	97		
1200	130	130	130	130	130	130	119	110	102	95			
1100	130	130	130	130	130	119	109	101	94				
1000	130	130	130	130	119	108	99	92					
900	130	130	130	119	107	98	90						
800	130	130	119	106	95	87							
700	130	130	119	104	93	84							
600	200	500	600	700	800	900	1000	1100	1200	1300	1400	1500	1600

2800	35	29	25	22	19	17	16	14	13	12	12		
2700	37	31	26	23	20	18	17	15	14	13	12		
2600	39	32	28	24	21	19	18	16	15	14	13		
2500	43	35	30	27	24	21	19	18	16	15	14	13	
2400	43	35	30	27	24	21	19	18	16	15	14	13	
2300	44	37	32	28	25	22	20	18	17	16	15	14	
2200	46	39	33	29	26	23	21	19	18	17	15	14	
2100	49	40	35	30	27	24	22	20	19	17	16	15	
2000	51	43	36	32	28	26	23	21	20	18	17	16	
1900	54	45	38	34	30	27	24	22	21	19	18	17	
1800	57	47	40	35	31	28	26	24	22	20	19	18	
1700	60	50	43	38	33	30	27	25	23	21	20	18	
1600	60	53	46	40	35	32	29	27	25	23	21	18	
1500	60	57	49	43	38	34	31	28	26	24	21	18	
1400	60	60	52	46	40	36	33	30	28	24	21	18	
1300	60	60	56	49	44	39	36	33	28	24	21	18	
1200	60	60	60	53	47	43	39	33	28	24	21		
1100	60	60	60	58	52	46	39	33	28	24			
1000	60	60	60	60	57	47	39	33	28				
900	60	60	60	60	58	47	39	33					
800	60	60	60	60	58	47	39						
700	60	60	60	60	58	47							
600	200	500	600	700	800	900	1000	1100	1200	1300	1400	1500	1600

Mandatory to use the FRIZ arm

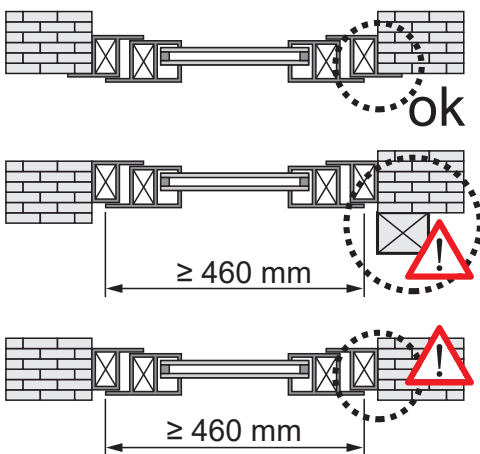

FRIZ arm positioning

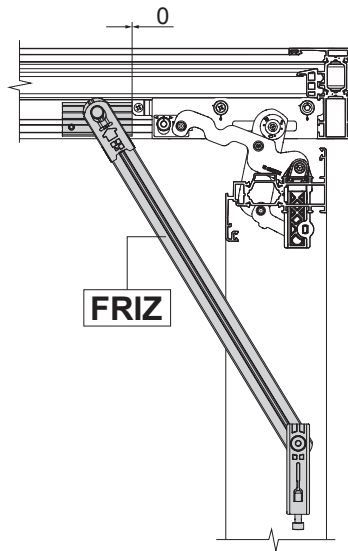

Opening angle with FRIZ arm

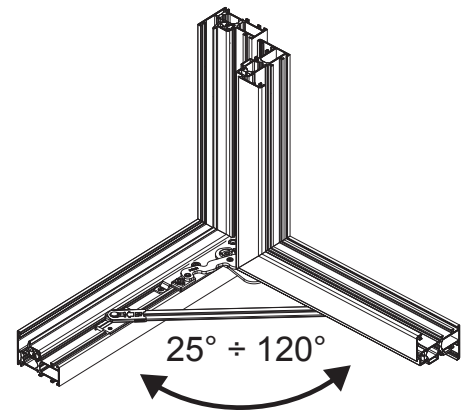

Item code	Description	PROFILE CROSS - SECTION	Hand	Base Raw	Anodised Elox	Painted	Trend/Gold Brass	Pieces per pack
052831	CHIC 130 ERRE - SASH HINGE SET	C007	RX	X				10
052832	CHIC 130 ERRE - SASH HINGE SET	C007	LX	X				10

CHIC HINGES FOR BOTTOM-HUNG WINDOWS



Functions

Hinge set for concealed Bottom-hung window.

Online data sheet



Technical Features

Total opening of the 180° hinge to facilitate its assembly.
 Fixing on the frame without machining, by means of pre-assembled cams.
 Sash height (+2.5 ÷ -0.5 mm) and compression (+1.4 ÷ -0.6 mm) adjustment, micrometric and independent of each other.
 The hinge is completed by 2 raising components that improve its stability.
 Maximum load capacity (*) 250 kg
 Minimum height (*) 3,000 mm
 (*) these are a consequence of the opening limiter used (see the opening limiters table).
 Maximum width 2,500 mm. Over 1,500 and 2,000 mm it is necessary to use no. 1 or no. 2 Raising components 04363 (see Raising component use scheme).

Materials

GS Silver PLUS zamak sash support
 Connecting brackets, hinge plates and cams in zinc plated steel
 AISI 304 stainless steel pins and screws
 Grey polyamide raising component

CHIC BOTTOM HUNG

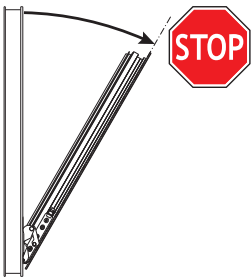
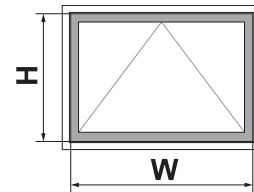

Compulsory: opening limiter.

Description	Item code	Capacities	W (mm)	H (mm)
RALLENTY (150mm)	02041K	50 kg	200÷2500	400÷1500
RALLENTY (250mm)	02040K	80 kg	200÷2500	570÷2500
FRIZ (140mm)	02800K	130 kg	200÷2500	420÷2500
FRIZ (300mm)	02030K	130 kg	200÷2500	580÷2500
FUTURA HP	01175K	250 kg	780÷2500	600÷3000

Raising component use

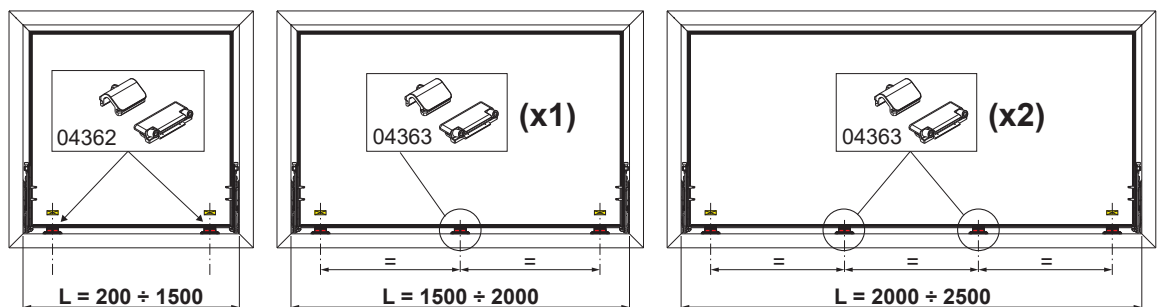
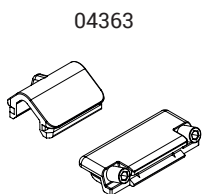

Height adjustment

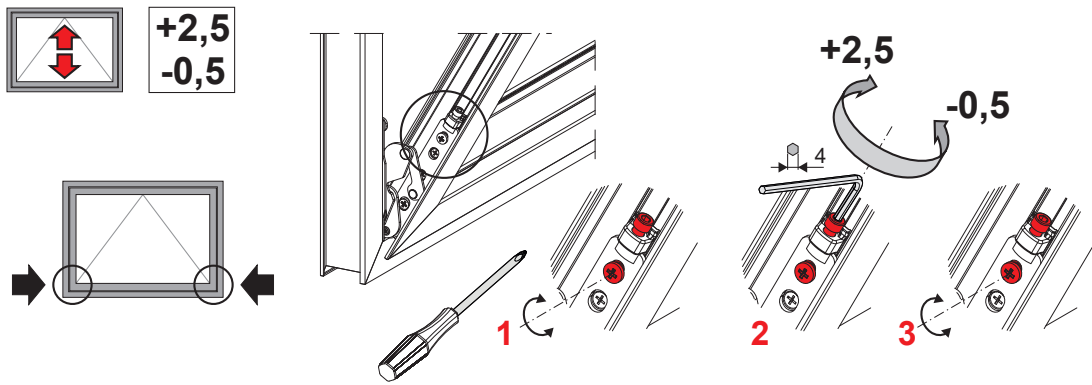

Compression adjustment

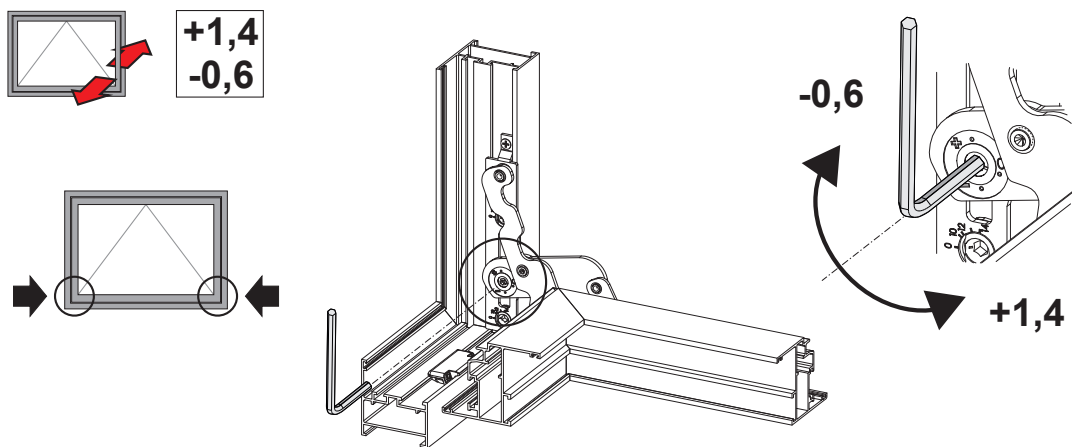

Item code	Description	Note	PROFILE CROSS - SECTION	Base Raw	Anodised Elox	Painted	Trend/Gold Brass	Pieces per pack
04362	CHIC - BOTTOM-HUNG WINDOW HINGE KIT	pair	C001-C002-C004-C005-C006	X				10
04363	CHIC - BOTTOM-HUNG WINDOW RAISING COMPONENT		C001-C002-C004-C005-C006	X				10

CHIC ERRE HINGES FOR BOTTOM-HUNG WINDOWS



Functions

Hinge set for concealed Bottom-hung window.

[Online data sheet](#)



Technical Features

Total opening of the 180° hinge to facilitate its assembly.
 Fixing on the frame without machining, by means of pre-assembled cams.
 Sash height (+2.5 ÷ -0.5 mm) and compression (+1.4 ÷ -0.6 mm) adjustment, micrometric and independent of each other.
 The hinge is completed by 2 raising components that improve its stability.
 Maximum load capacity (*) 250 kg
 Minimum height (*) 3,000 mm
 (*) these are a consequence of the opening limiter used (see the opening limiters table).
 Maximum width 2,500 mm. Over 1,500 and 2,000 mm it is necessary to use no. 1 or no. 2 Raising components 05296 (see Raising component use scheme).

Materials

GS Silver PLUS zamak sash support
 Connecting brackets, hinge plates and cams in zinc plated steel
 AISI 304 stainless steel pins and screws
 Grey polyamide raising component

CHIC BOTTOM HUNG

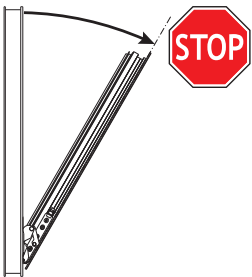
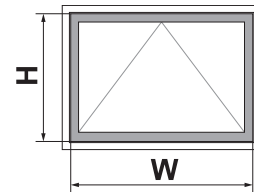

Compulsory: opening limiter.

Description	Item code	Capacities	W (mm)	H (mm)
RALLENTY (150mm)	02043K	50 kg	200÷2500	400÷1500
RALLENTY (250mm)	02042K	70 kg	200÷2500	570÷1500
FRIZ (300mm)	02034K	70 kg	200÷2500	580÷2500
FUTURA HP	01207	250 kg	780÷2500	600÷3000

Raising component use

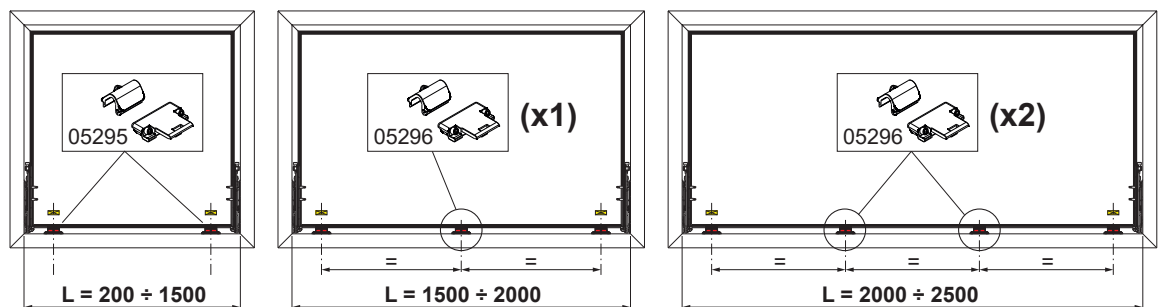
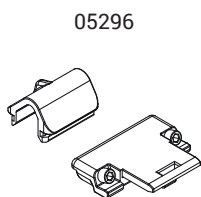

Height adjustment

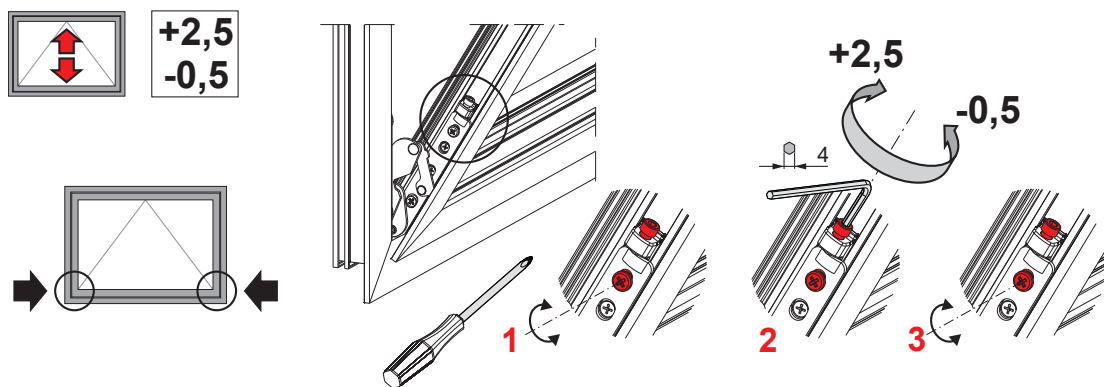

Compression adjustment

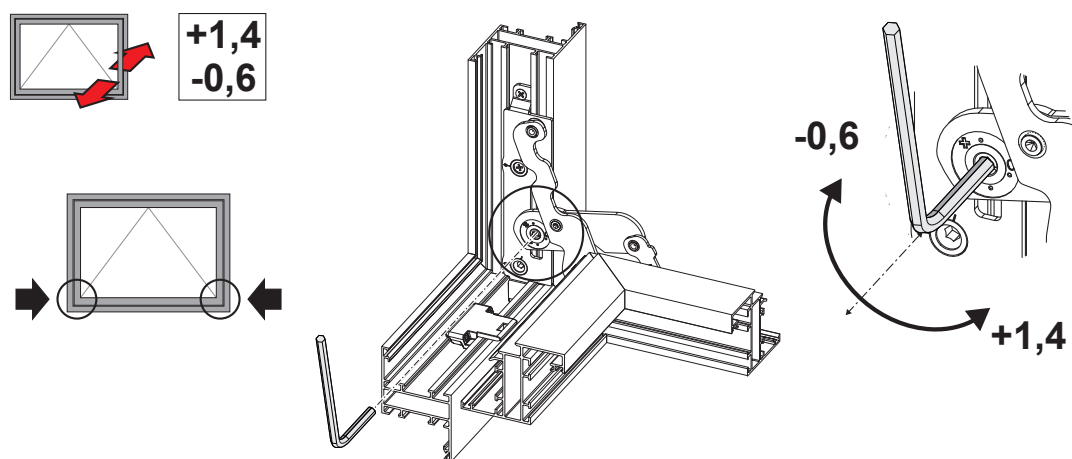

Item code	Description	Note	PROFILE CROSS - SECTION	Base Raw	Anodised Elox	Painted	Trend/Gold Brass	Pieces per pack
05295	CHIC ERRE - BOTTOM-HUNG WINDOW HINGES KIT	pair	C007	X				10
05296	CHIC ERRE - BOTTOM-HUNG WINDOW HINGES RAISING COMPONENT		C007	X				10

INVISIBLE SASH HINGE KIT



Functions

FUTURA 3D 170 HP Invisible hinge set (top and bottom) for side-hung sash or secondary sash combined with turn-and-tilt sash.

Online data sheet



Technical Features

The product is designed for sash profiles with smooth channel. In the case of profiles with undercut channel, shims item 04406 (1.5 mm) or item 04407 (2 mm) must be used.

Materials

Hinge in stainless steel and zamak, pin and grub screws in stainless steel
Polyamide bushes

Capacities

The product has a nominal load capacity of 130 kg. For higher load capacities up to 170 kg, reinforcement kit item 04409 or item 04411 is required.

Assembly

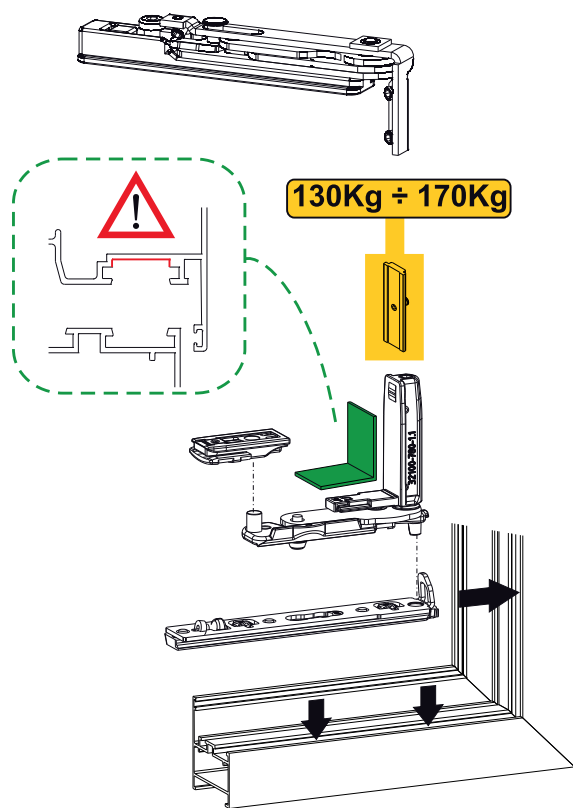

Shims for FUTURA 3D 170 HP Invisible

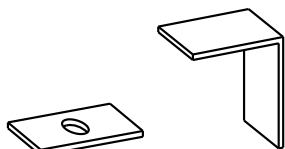

Sash drop adjustment

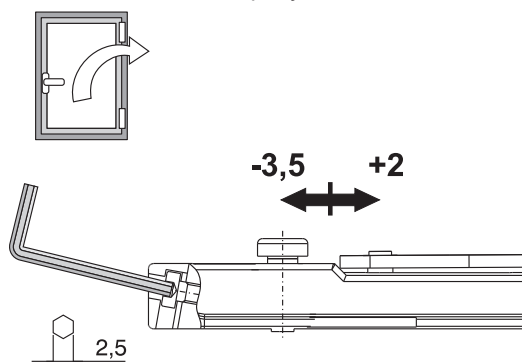

Side and vertical adjustment

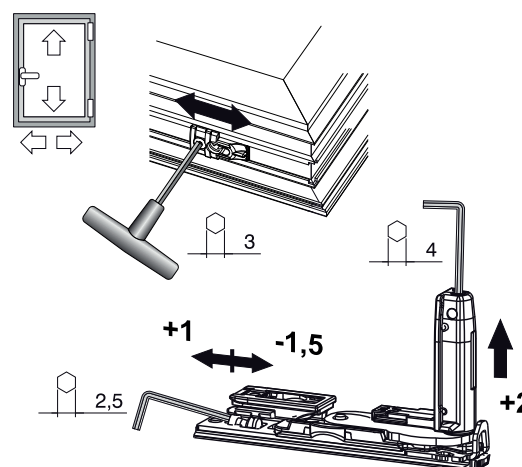

Futura 3D Invisible <130 kg
Maximum allowable thickness of glass

2500	43	39	36	31	27	24	22	20	18	17	15	14	14	13	
2400	45	41	38	32	28	25	23	21	19	17	16	15	14	13	
2300	47	43	39	34	30	26	24	21	20	18	17	16	15	14	
2200	50	45	41	35	31	28	25	23	21	19	18	17	15	15	
2100	50	47	43	37	33	29	26	24	22	20	19	17	16	15	
2000	50	50	46	39	34	30	27	25	23	21	20	18	17	16	
1900	50	50	48	41	36	32	29	26	24	22	21	19	18	17	
1800	50	50	50	44	38	34	31	28	25	24	22	20	19	18	
1700	50	50	50	46	41	36	33	30	27	25	23	22	20	19	
1600	50	50	50	50	43	39	35	32	29	27	25	23	22	19	
1500	50	50	50	50	46	41	37	34	31	29	27	25	22	19	
1400	50	50	50	50	44	40	36	33	31	29	25	22	19		
1300	50	50	50	50	48	43	39	36	33	29	25	22			
1200	50	50	50	50	50	47	43	39	33	29	25				
1100	50	50	50	50	50	50	47	39	33	29					
1000	50	50	50	50	50	50	50	47	39	33					
900	50	50	50	50	50	50	50	47	39						
800	50	50	50	50	50	50	50	47							
700	50	50	50	50	50	50	50								
600	430	500	550	600	700	800	900	1000	1100	1200	1300	1400	1500	1600	1700

Futura 3D Invisible <130 kg
Maximum permissible load capacity

2500	130	130	130	130	130	130	130	130	130	130	130	130	130	130	
2400	130	130	130	130	130	130	130	130	130	130	130	130	130	130	
2300	130	130	130	130	130	130	130	130	130	130	130	130	130	130	
2200	130	130	130	130	130	130	130	130	130	130	130	130	130	130	
2100	130	130	130	130	130	130	130	130	130	130	130	130	130	130	
2000	130	130	130	130	130	130	130	130	130	130	130	130	130	130	
1900	130	130	130	130	130	130	130	130	130	130	130	130	130	130	
1800	130	130	130	130	130	130	130	130	130	130	130	130	130	130	
1700	130	130	130	130	130	130	130	130	130	130	130	130	130	130	
1600	130	130	130	130	130	130	130	130	130	130	130	130	130	122	
1500	130	130	130	130	130	130	130	130	130	130	130	130	121	114	
1400	130	130	130	130	130	130	130	130	130	130	130	130	121	113	106
1300	130	130	130	130	130	130	130	130	130	130	130	120	111	104	
1200	130	130	130	130	130	130	130	130	130	130	119	110	102		
1100	130	130	130	130	130	130	130	130	130	118	108	100			
1000	130	130	130	130	130	130	130	117	106	98					
900	130	130	130	130	130	130	116	104	95						
800	130	130	130	130	130	114	101	91							
700	130	130	130	130	111	98	87								
600	430	500	550	600	700	800	900	1000	1100	1200	1300	1400	1500	1600	1700

Futura 3D Invisible 130kg - 170 kg
Maximum allowable thickness of glass

2500	43	39	47	40	35	31	28	26	24	22	20	19	18	17	
2400	45	41	49	42	37	33	30	27	25	23	21	20	18	17	
2300	47	43	50	44	39	34	31	28	26	24	22	21	19	18	
2200	50	45	50	46	40	36	32	29	27	25	23	22	20	19	
2100	50	47	50	49	43	38	34	31	28	26	24	23	21	19	
2000	50	50	50	50	45	40	36	33	30	28	26	24	22	19	
1900	50	50	50	50	47	42	38	34	31	29	27	25	22	19	
1800	50	50	50	50	44	40	36	33	31	29	25	22	19		
1700	50	50	50	50	47	43	39	35	33	29	25	22	19		
1600	50	50	50	50	50	45	41	38	33	29	25	22	19		
1500	50	50	50	50	50	49	44	39	33	29	25	22	19		
1400	50	50	50	50	50	50	47	39	33	29	25	22	19		
1300	50	50	50	50	50	50	47	39	33	29	25	22			
1200	50	50	50	50	50	50	47	39	33	29	25				
1100	50	50	50	50	50	50	47	39	33	29					
1000	50	50	50	50	50	50	47	39	33						
900	50	50	50	50	50	50	47	39							
800	50	50	50	50	50	50	47								
700	50	50	50	50	50	50									
600	430	500	550	600	700	800	900	1000	1100	1200	1300	1400	1500	1600	1700

Futura 3D Invisible 130kg - 170 kg
Maximum permissible load capacity

2500	130	130	170	170	170	170	170	170	170	170	170	170	170	170	
2400	130	130	170	170	170	170	170	170	170	170	170	170	170	170	
2300	130	130	170	170	170	170	170	170	170	170	170	170	170	170	
2200	130	130	170	170	170	170	170	170	170	170	170	170	170	170	
2100	130	130	170	170	170	170	170	170	170	170	170	170	170	163	
2000	130	130	170	170	170	170	170	170	170	170	170	170	165	154	
1900	130	130	170	170	170	170	170	170	170	170	170	167	156	146	
1800	130	130	170	170	170	170	170	170	170	170	170	158	147	138	
1700	130	130	170	170	170	170	170	170	170	170	170	160	149	139	130
1600	130	130	170	170	170	170	170	170	170	170	163	150	139	130	122
1500	130	130	170	170	170	170	170	170	165	152	140	130	121	114	
1400	130	130	170	170	170	170	170	169	154	141	130	121	113	106	
1300	130	130	170	170	170	170	156	142	130	120	111	104			
1200	130	130	170	170	170	170	159	143	130	119	110	102			
1100	130	130	170	170	170	163	144	130	118	108	100				
1000	130	130	170	170	167	146	130	117	106	98					
900	130	130	170	170	149	130	116	104	95						
800	130	130	165	152	130	114	101	91							
700	130	130	142	130	111	98	87								
600	430	500	550	600	700	800	900	1000	1100	1200	1300	1400	1500	1600	1700

Reinforcement for FUTURA 3D 170 HP Invisible

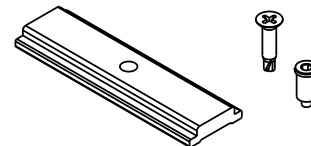

Item code	Description	Notes	PROFILE CROSS - SECTION	Hand	Base Raw	Anodised Elox	Painted	Trend/Gold Brass	Pieces per pack
044001	INVISIBLE SASH HINGE KIT		C001	RX	X				10
044002	INVISIBLE SASH HINGE KIT		C001	LX	X				10

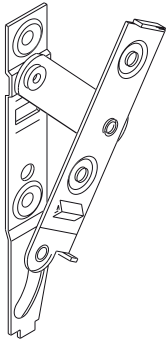

HINGES FOR BOTTOM-HUNG WINDOWS

Functions

Hinge for bottom-hung windows, fast assembly and secure fixing.
Enables opening a bottom-hung window without any hinges being exposed to view.

Online data sheet



Technical Features

It is fixed with cams and plates and requires no adaptation or modification of seals for assembly.

Enables bottom-hung opening of the sash to an angle of 32°.

Given its application and operation internally of the groove, bottom hung window fixtures can be assembled without any hinges exposed to view.

Materials

Hinge and plates of zinc-nickel plated steel

Stainless steel plates

Screws and long plates of zinc-nickel plated steel

Parts

8 TSP M5x8 screws

4 threaded cam plates

2 long threaded plates

Capacities

with 2 hinges:

20 kg assuming fixtures of maximum height 700 mm

Minimum height 170 mm

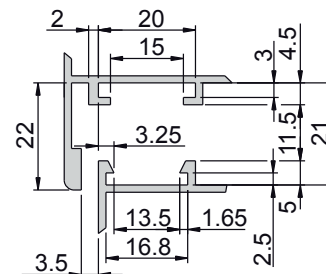
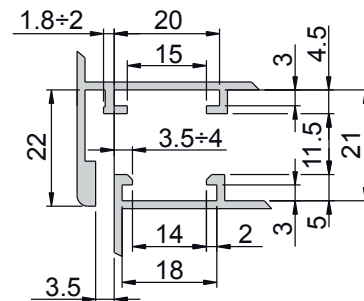
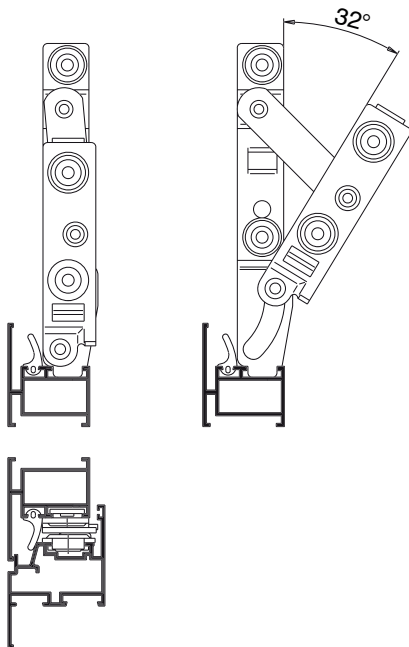

Item code	Description	Note	PROFILE CROSS - SECTION	Base Raw	Anodised Elox	Painted	Trend/Gold Brass	Pieces per pack
0205101	HINGES FOR BOTTOM-HUNG WINDOWS	pair	C001	X				10

BRIDGE 2 HINGES

Functions

Clamp hinge for lightweight windows and door fixtures made with channel profile.

Online data sheet

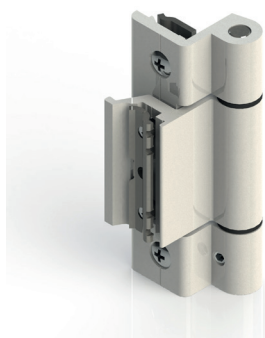

Technical Features

Two-handed hinge suitable for lightweight door fixtures and bottom hung or projecting type windows.

Supplied preassembled (except the plate for fixing the hinge on the frame side) to enable fast installation and faultless positioning of the hinge on already assembled fixtures.

The special shape of fixing plate fitted to the sash (Giesse RAPID system) guarantees the firmest possible attachment of the hinge to the profile.

Removable pin allowing separation of sash from frame without detaching the hinge from the profile.

Materials

Extruded aluminium hinge bodies
Pin, fixing plates, screws and grub screw, all stainless steel

Acetal resin bushes

Capacities

90 kg with 2 hinges

100 kg with 3 hinges

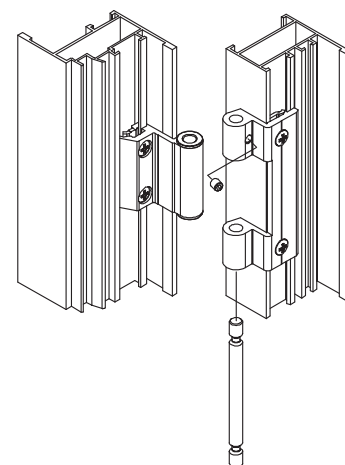
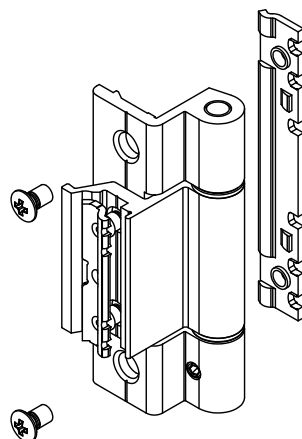
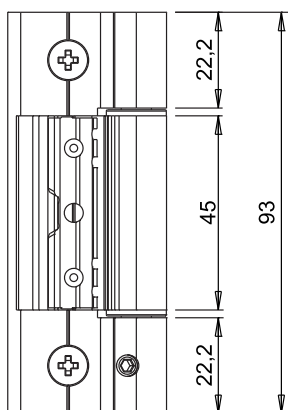

Item code	Description	PROFILE CROSS - SECTION	Third sash	Load capacity 2 hinges [kg]	Load capacity 3 hinges [kg]	Base Raw	Anodised Elox	Painted	Trend/Gold Brass	Pieces per pack
00600N	BRIDGE 2 HINGE	C001-C002		90	100	X	X	X	X	20
00601N	BRIDGE 2 HINGE	C001	x	90	100	X	X	X	X	20
00602N	BRIDGE 2 HINGE	C007		90	100	X	X	X	X	20
00603N	BRIDGE 2 HINGE		x	90	100	X	X	X	X	20
00604N	BRIDGE 2 HINGE	C008		90	100	X	X	X	X	20
00605N	BRIDGE 2 HINGE		x	90	100		X	X	X	20
00606N	BRIDGE 2 HINGE	C009		90	100	X	X	X	X	20
00607N	BRIDGE 2 HINGE		x	90	100	X	X	X	X	20
00609N	BRIDGE 2 HINGE	C005		90	100	X	X	X		20

Note: For the «Third sash» hinges, check the correct series on Where-used.

CLAMP DOOR HINGES



CELERA HINGES

Functions

Clamp door hinge for profile with channel.
Side adjustment with door installed.

Online data sheet



Technical Features

This hinge is suitable for doors subject to intensive use with high resistance to fatigue and wear.

Fixing plates of special geometry guarantee the firmest possible attachment on the profile channel.

The CELERA hinge is fitted extremely quickly to the sash and frame, even when the fixture has already been installed, thanks to the fixing plates that are pre-assembled to the hinge bodies (Giesse RAPID system).

It is therefore possible to apply an additional hinge (for example in the center) even after installation without having to dismantle the sash.

Side adjustment (± 1 mm), obtainable by turning the eccentric bush in the sash hinge using a 6mm hex wrench.

Materials

Extruded aluminium hinge bodies

$\varnothing 10$ pin, fixing plates and fixing screws, all stainless steel

Eccentric bush, adjustment locking element and washer made of acetal resin

Polyamide cap

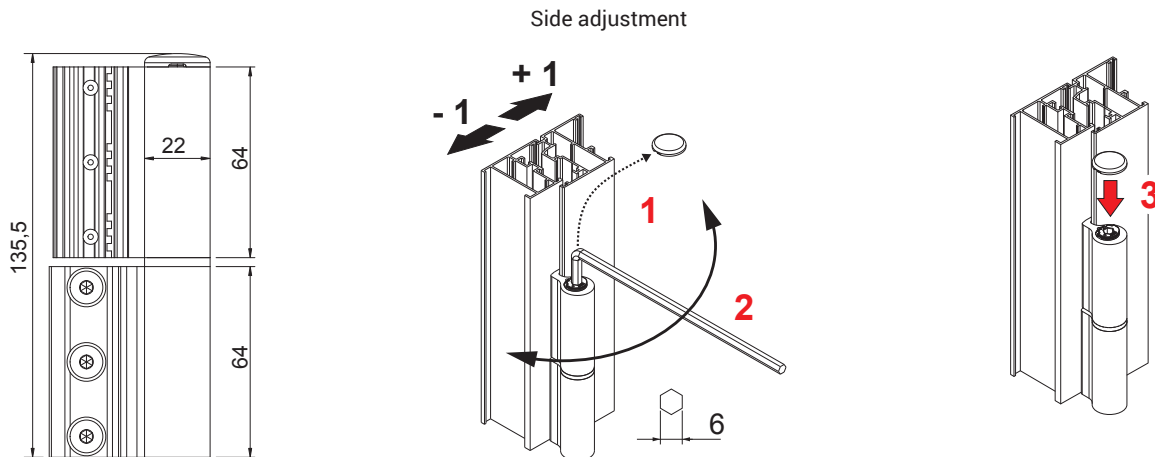

Item code	Description	PROFILE CROSS - SECTION	Flush opening	Third sash	Load capacity 2 hinges [kg]	Load capacity 3 hinges [kg]	CE marking	Base Raw	Anodised Elox	Painted	Trend/Gold Brass	Pieces per pack
00681	CELERA HINGE	C001 - C002 - C005			100	120	CLASS 12	X	X	X		20
00682	CELERA HINGE	C007			100	120	-	X	X	X		20
00684	CELERA HINGE	see Where Used	X		100	120	CLASS 12	X	X	X		20
00685	CELERA HINGE	see Where Used			90	110	-	X	X	X		20
00687	CELERA HINGE	C008			90	110	-	X	X	X		20
00688	CELERA HINGE	C009			100	120	-	X	X	X		20
00689	CELERA HINGE	see Where Used			100	120	-	X	X	X		20
00690	CELERA HINGE	see Where Used		X	80	100	-	X	X	X	X	20



FULCRA HINGES

Functions

Clamp door hinge for profile with channel and adjustable in three directions (height, width and compression).

Thanks to the innovative adjustment system (patented) the two hinge bodies are always kept in line regardless of the sideways shift performed.

Online data sheet



Technical Features

Hinge suitable for doors subject to intensive use (use category 4* - heavy duty use).

The innovative adjustment system (patented) makes it easier and more accurate to align the sash to the frame, always ensuring the perfect alignment of the two hinge bodies.

Fixing plates of special geometry guarantee the firmest possible attachment on both sides of the profile channel.

The additional strengthening screws on the frame plate increase the slip resistance.

The height adjustment device also acts as an axial bearing, increasing the resistance to fatigue of the hinge (durability grade 7* - 200,000 opening cycles).

Adjustments in the three directions:

- Side adjustment (± 2 mm.), using an Allen key on the eccentric pin, then locking it in the desired position by means of two grub screws.
- Height adjustment ($0/+ 3$ mm.), using an Allen key on the grub screw integral with the frame hinge body.
- Compression adjustment ($\pm 0,5$ mm.), obtainable by turning the eccentric bush in the frame hinge body.

(*) Complies with EN1935

Materials

Extruded aluminium hinge bodies

Stainless steel pin

Zamak grub screw for vertical adjustment with sealed galvanised finish

Stainless steel fixing plates, grub screws and screws

Eccentric technopolymer bush

Polyamide plugs and centering bushing

Capacities

120 kg with 2 hinges

150 kg with 3 hinges

CE Mark in compliance EN1935

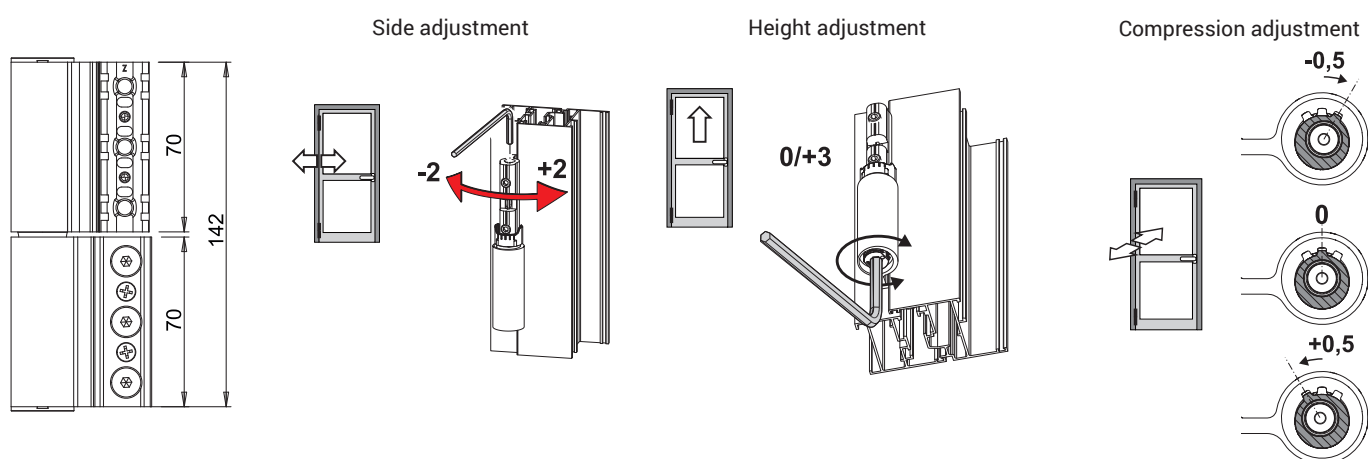

Item code	Description	PROFILE CROSS - SECTION	Flush opening	Opening	Load capacity 2 hinges [kg]	Load capacity 3 hinges [kg]	CE marking	Base Raw	Anodised Elox	Painted	Trend/Gold Brass	Pieces per pack
00700	FULCRA HINGE EURO GROOVE	C001	-	Internal	120	150	Class 13	X	X	X	X	10
00701	FULCRA HINGE R40	C007-C008	-	Internal	120	150	Class 12	X	X	X	X	10
00702	FULCRA HINGE OUTWARD OPENING EURO GROOVE	see Where Used	Yes	External	100	120	Class 11	X	X	X	X	10
00703	FULCRA ALU 16 HINGE	see Where Used	-	Internal	110	130	Class 12	X	X	X		10

FLASH XXL HINGES

Functions

Clamp door hinge for profile with channel, adjustable in two directions with door installed.
For combination with aluminium covers purchased separately from the hinge.

Online data sheet



Technical Features

Hinge suitable for doors subject to intensive use (use category 4* - heavy duty use).

Ideal for the assembly of doors characterized by large dimensions, heavy weight and intensive use.

The thrust bearing located between the two hinge bodies increases resistance of the hinge to fatigue and wear (durability grade 7* - 200,000 test cycles).

The frame hinge leaf is fixed to the profile with self-tapping screws passing through the hinge body, to increase the stability of the system.

Totally or partially removable pin, allowing assembly of sash to frame even in situations where space is markedly restricted.

Adjustments in two directions with door installed:

- side adjustment (± 1 mm), obtainable by turning the eccentric bush in the sash part of the hinge with special key item 03900.

- height adjustment (-2/+4 mm) obtainable by means of sash lift support block supplied with the hinge, to be positioned against the top hinge sash leaf

The hinge is to be coupled to the covers for the sash hinge and frame hinge (art. 00599), can be painted and coated, sold separately. Fitting the cover on completing installation avoids damaging the visible parts of the hinge during assembly, transport and installation.

Special preload plate supplied with the product, to be positioned against the sash part of the bottom hinge, guaranteeing correct alignment of sash and frame under high loading conditions.

The plate can also be purchased separately (item 00591) as a replacement for the standard plates supplied with the hinge, when assembling doors supplied with three hinges, including a centrally positioned third hinge.

* Complies with EN 1935

Materials

Extruded aluminium hinge bodies, anodized black
 $\varnothing 10$ pin, thrust bearing, screws and grub screw, all stainless steel

Eccentric bush, acetal resin

Extruded aluminium fixing plates

Extruded aluminium preload plate

Lift support block, diecast zamak

Height adjustment grub screw, zinc-coated steel

Polyamide cap

Extruded aluminium cover

Capacities

160 kg with 2 hinges

180 kg with 3 hinges

CE Mark in compliance EN1935

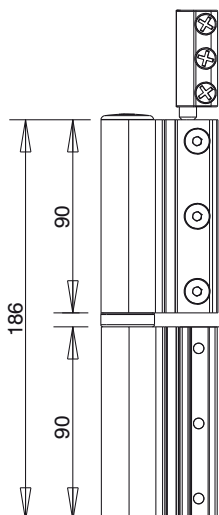

Self-tapping screws

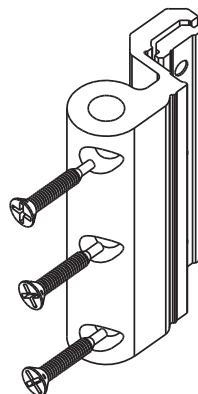

Preload plate

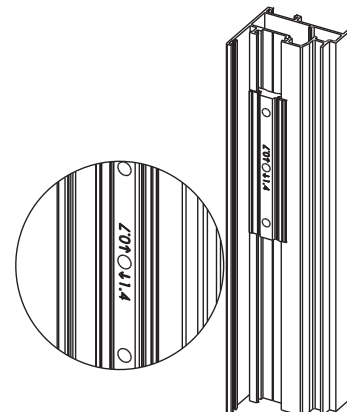

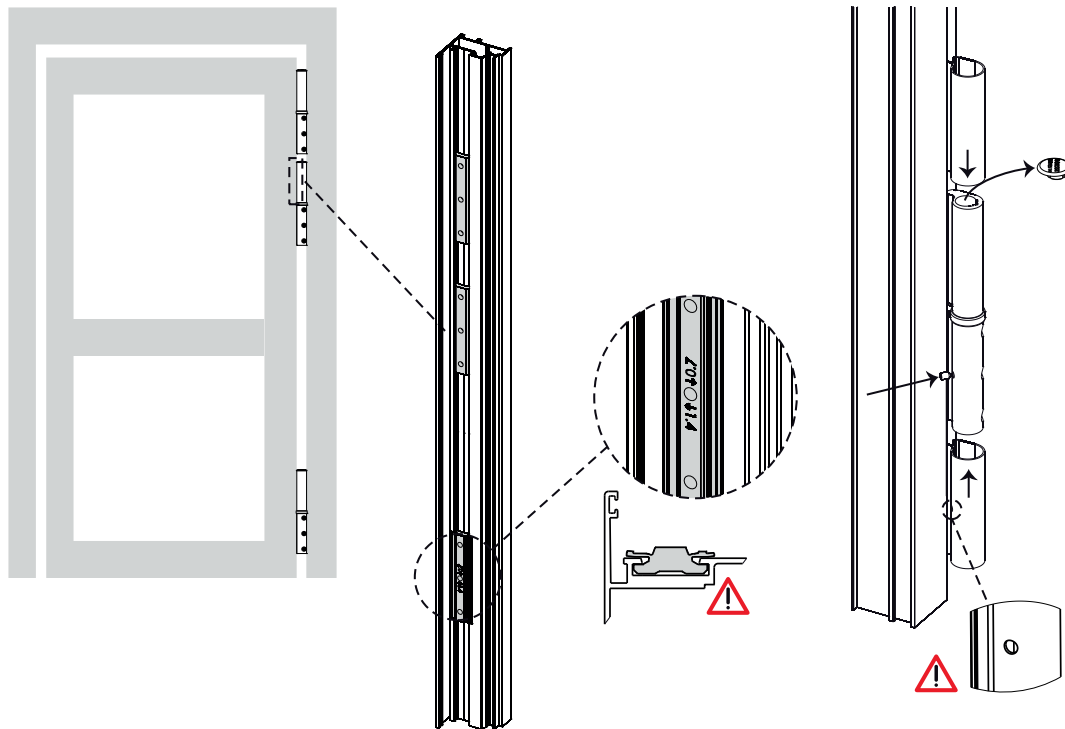
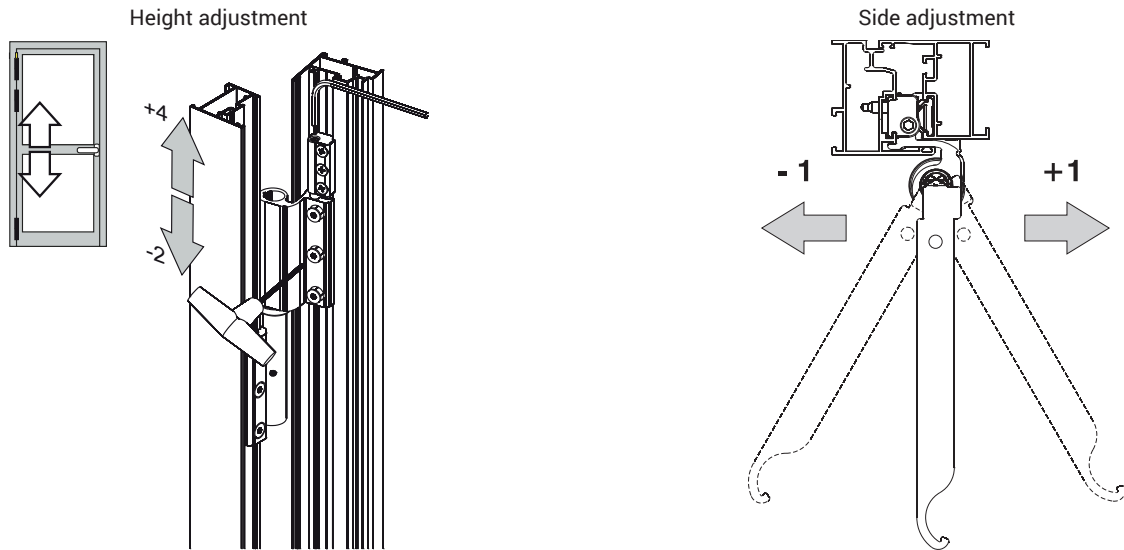

Item code	Description	PROFILE CROSS - SECTION	Step	Flush opening	Third sash	Load capacity 2 hinges [kg]	Load capacity 3 hinges [kg]	CE marking	Base Raw	Anodised Elox	Painted	Trend/Gold Brass	Pieces per pack
00561	FLASH XXL FIXING PLATES	C001	-	-	-	-	-	-	X				10
00591	FLASH XXL PRE-LOAD FIXING PLATES	C001-C002	-	-	-	-	-	-	X				10
00598N	FLASH XXL HINGE	C001	8 mm max	-	-	160	180	Class 14		X			20
00599	COVER, FLASH XXL HINGE	C001	-	-	-	-	-	-	X	X	X	X	20

FLASH XLR HINGES

Functions

Clamp door hinge for profile with channel.
Adjustable in two directions.

[Online data sheet](#)



Technical Features

Hinge suitable for doors subject to intensive use (use category 4* - heavy duty use).

Fixing plates of special geometry, insertable from the side into the channel of the sash and frame profiles when already assembled, guarantee the firmest possible attachment to the profile.

The thrust bearing located between the two hinge bodies increases resistance of the hinge to fatigue and wear (durability grade 7* - 200,000 test cycles).

Adjustments in two directions with door installed:

- side adjustment (± 2 mm), obtainable by turning the eccentric bushes in the hinges with special key item 03900

- height adjustment (-2/+4 mm) obtainable by means of sash lift support block supplied with the hinge, to be positioned against the sash leaf.

* Complies with EN 1935

Materials

Extruded aluminium hinge bodies
 $\varnothing 10$ pin, thrust bearing, fixing plates and fixing screws, all stainless steel

Lift support block, extruded aluminium

Height adjustment grub screw, stainless steel

Eccentric bushes, acetal resin

Polyamide caps

Capacities

120 kg with 2 hinges

140 kg with 3 hinges

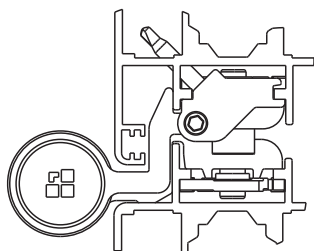
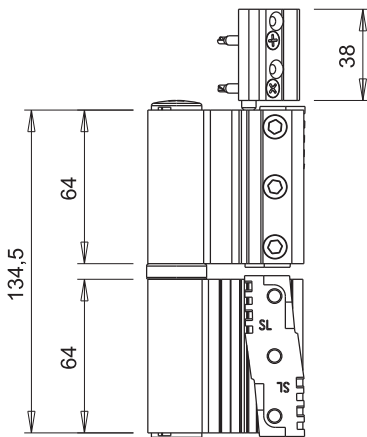

Side adjustment

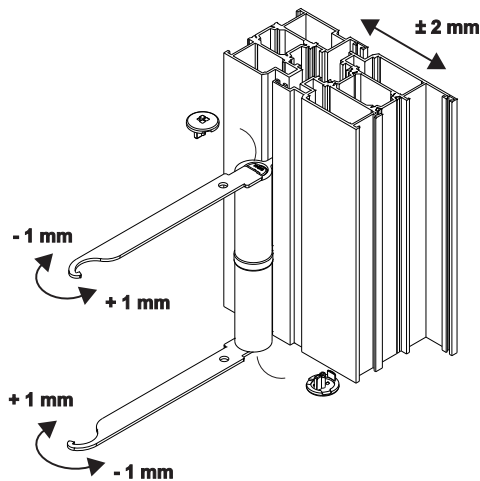

Height adjustment

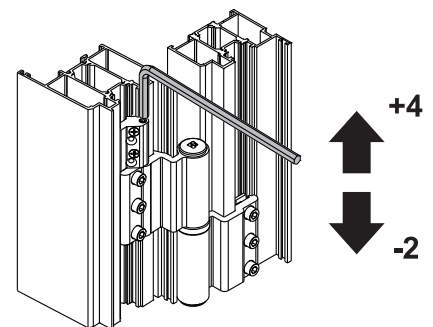

Section 1

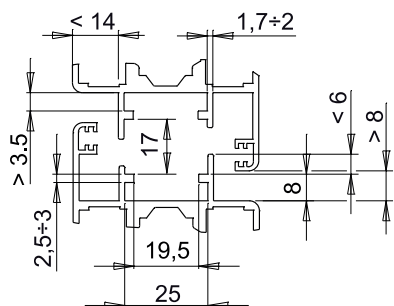

Section 2

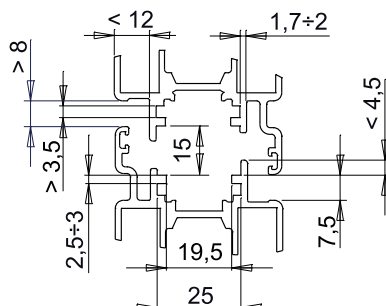

Section 3

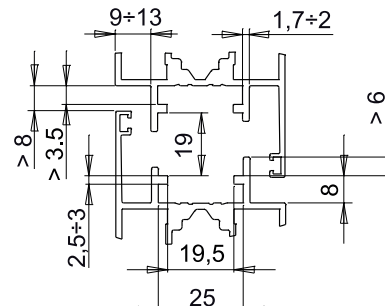

Section 5

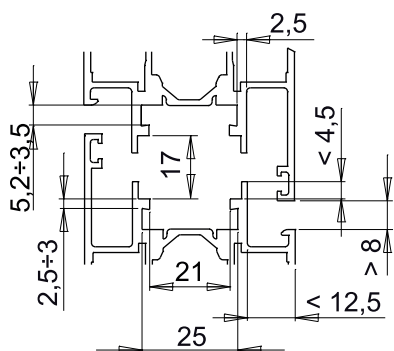

Section 6

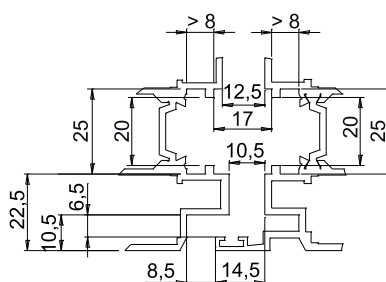

Item code	Description	Application reference section	Load capacity 2 hinges [kg]	Load capacity 3 hinges [kg]	Base Raw	Anodised Elox	Painted	Trend/Gold Brass	Pieces per pack
00925N	FLASH XLR HINGE	section 1	120	140	X	X	X		20
00926N	FLASH XLR HINGE	section 2	120	140	X	X	X		20
00927N	FLASH XLR HINGE	section 3	120	140	X	X	X		20
00929N	FLASH XLR HINGE	section 5	120	140	X	X	X		20
00930	FLASH XLR HINGE	section 6	120	140	X	X	X		20

CLAMP DOOR HINGES



FLASH SLR HINGES

Functions

Clamp door hinge for profile with channel.
Adjustable in one direction.

Online data sheet



Technical Features

Hinge suitable for doors subject to intensive use (use category 4* - heavy duty use).

Fixing plates of special geometry, insertable from the side into the channel of the sash and frame profiles when already assembled, guarantee the firmest possible attachment to the profile.

Side adjustment (± 1 mm) obtainable with door installed by turning the eccentric bush in the sash part of the hinge with special key item 03900.

With the removable pin, the sash can be separated from the frame without lifting (e.g. where space is restricted).

* Complies with EN 1935

Materials

Extruded aluminium hinge bodies
 $\varnothing 10$ pin, fixing plates and fixing screws, all stainless steel

Eccentric bush and washer, acetal resin

Polyamide cap

Capacities

120 kg with 2 hinges

140 kg with 3 hinges

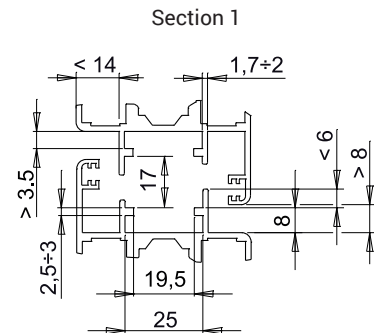
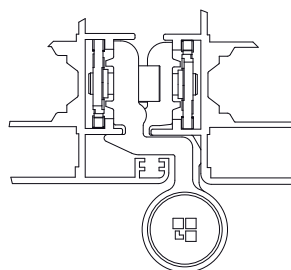
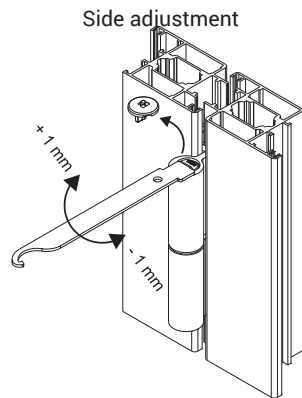
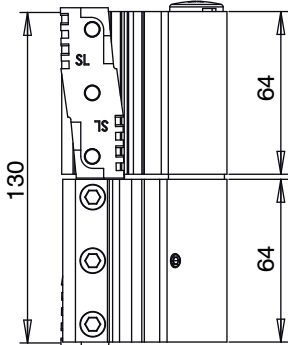

Item code	Description	Application reference section	Load capacity 2 hinges [kg]	Load capacity 3 hinges [kg]	Base Raw	Anodised Elox	Painted	Trend/Gold Brass	Pieces per pack
00940	FLASH SLR HINGE	section 1	120	140	X	X	X		20



BRIDGE HINGES

Functions

Front mounting clamp hinge, for lightweight doors and windows.

[Online data sheet](#)



Technical Features

With a completely removable pin, the sash can be separated from the frame without detaching the hinge from the profile.

The pin is held fast internally of the hinge body by a grub screw, accessible only when the sash is open.

Fixing to the hinge is by means of the plates, supplied with the hinge, which are inserted into the hollow section and/or the shoulder of the profile.

The profile is drilled with the aid of template item 03218.

Materials

Extruded aluminium hinge bodies

Pin, fixing plates, screws and grub screw, all stainless steel

Acetal resin bushes

Parts

2 fixing plates

6 TPS M5x10 screws

1 Grub screw M5x6

Capacities

75 kg with 2 hinges

85 kg with 3 hinges

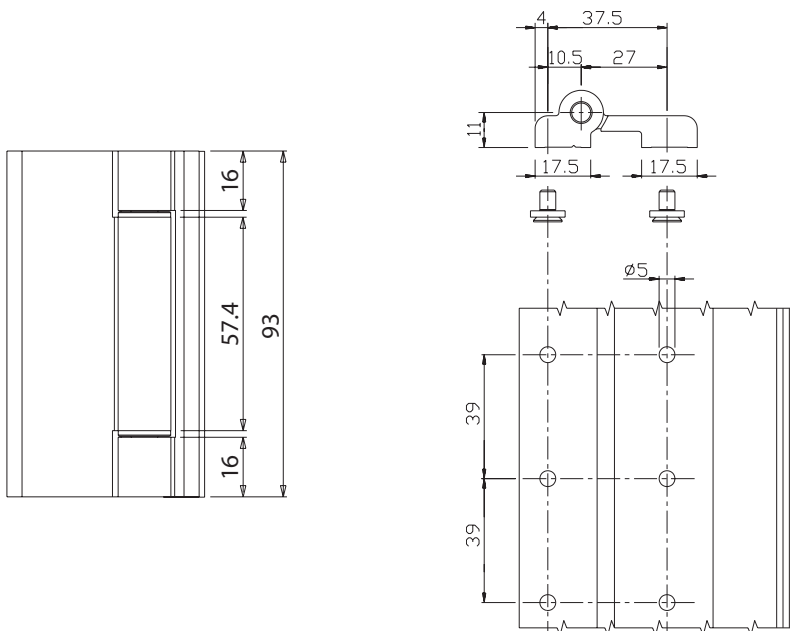

Profile machining template item 03218

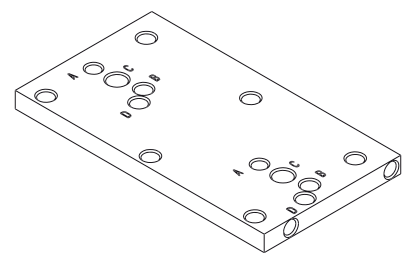

Item code	Description	Note	Base Raw	Anodised Elox	Painted	Trend/Gold Brass	Pieces per pack
00112N	SURFACE MOUNTING BRIDGE HINGE		X	X	X		20

DOMINA CLASSIC HINGE

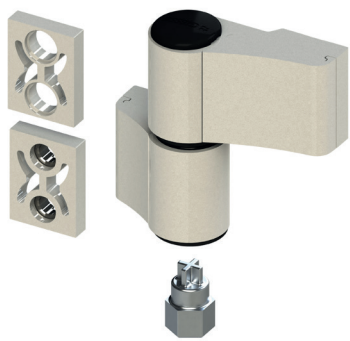

Functions

Surface mounting hinge, 2 or 3 wing version for heavy doors made of aluminium.

Adjustable in three directions.

For combination with counterplate kit, with expansion dowels for single sealed unit profiles and with M12 direct fixing screw for thermal break profiles.

[Online data sheet](#)



Technical Features

Hinge suitable for doors subject to intensive use (use category 4* - heavy duty use) with high resistance to fatigue and wear (durability grade 7* - 200,000 test cycles).

Ideal for the assembly of doors characterized by large dimensions, heavy weight and intensive use.

Adjustments in three directions:

- micrometric side adjustment (± 2.5 mm) with door installed, obtainable by turning the adjustment screw located in the sash hinge cartridge
- micrometric vertical adjustment (0-4 mm) with door installed, obtainable by turning the grub screw located at the bottom of the frame part of the hinge, using the special adapter supplied with the product
- compression adjustment (± 0.5 mm), obtainable by turning the eccentric bush in the frame part of the hinge to the angular position required.

Screw-cover plates fixed to hinge using pull screws driven from the inside (for locking purposes use clip item 05051), removable only with the sash open (tamper-proof).

For combination with counterplate kit, with expansion dowels for single sealed unit profiles and with M12 direct fixing screws for thermal break profiles.

Profile can be prepared with $\varnothing 11$ mm holes (for all fixing systems) using drill templates item 03237 and item 05052

When applied to a non-flush profile, the hinge is fitted in combination with shim steps selected according to the type of fixing used for the profile:

- steps with centering bushes: for counterplate kit and expansion dowels for single sealed unit profile
- steps without centering bushes: for M12 direct fixing screws.

* Complies with EN 1935



Ask to your sales rep for product availability.

Materials

Extruded aluminium hinge bodies and screw-cover plates

Zamak pin cartridge with GS Silver Plus finish (up to 500 h corrosion resistance)

$\varnothing 11$ pin, stainless steel

Side adjustment screw made of treated steel ensuring high resistance to corrosion

Eccentric cartridge, cover ring and vertical set-screw, acetal resin

Screw concealer plate fixing screws, zinc-coated steel

Polyamide concealer caps

Capacities

Up to 120 kg with two 2-wing hinges

Up to 140 kg with three 2-wing hinges

Up to 160 kg with two 3-wing hinges

Up to 180 kg with three 3-wing hinges

CE Mark in compliance EN1935

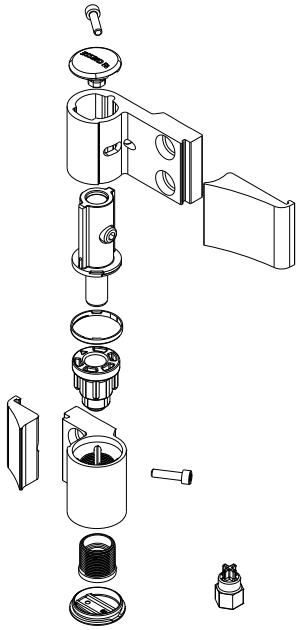

Machining on profile (2 wings)

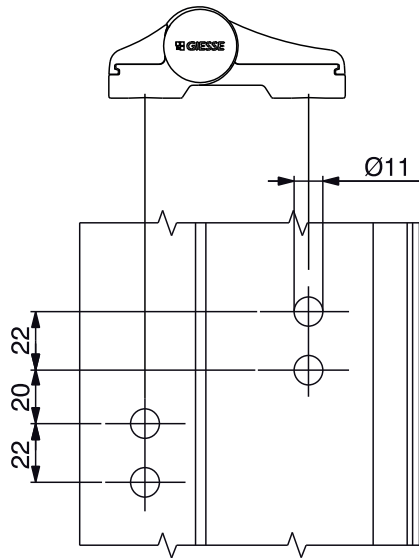

Machining on profile (3 wings)

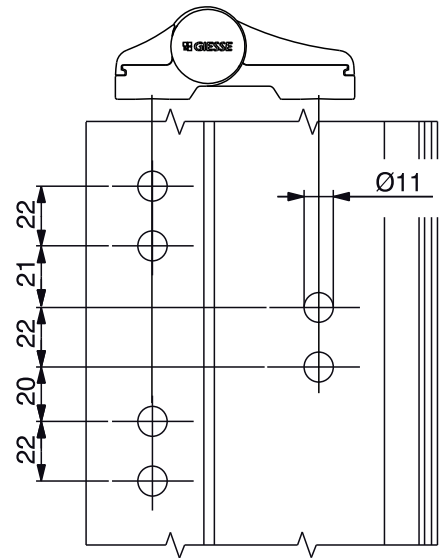

Side adjustment

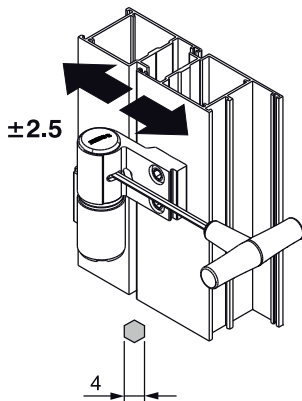

Height adjustment

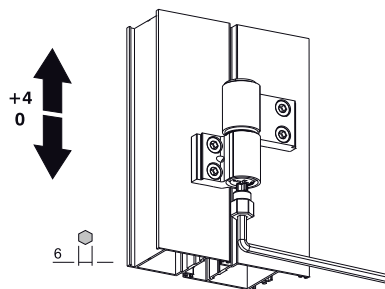

Compression adjustment

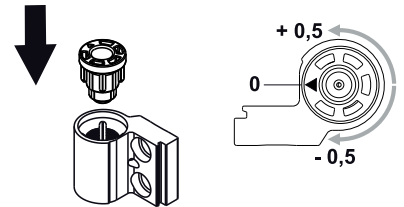

Steps with bushes

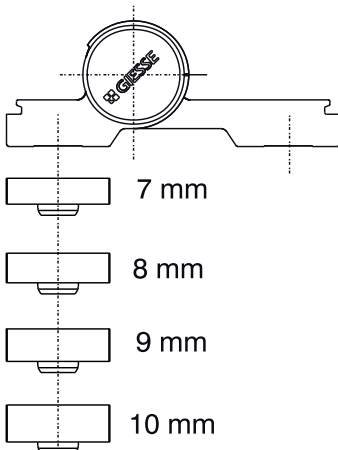

Steps without bushes

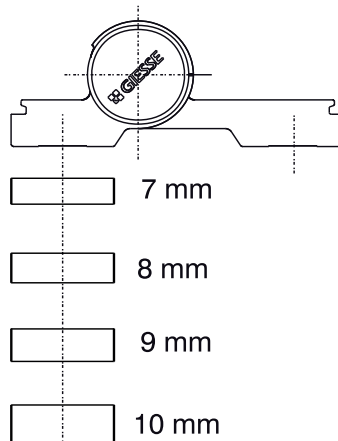

Use of locking clips

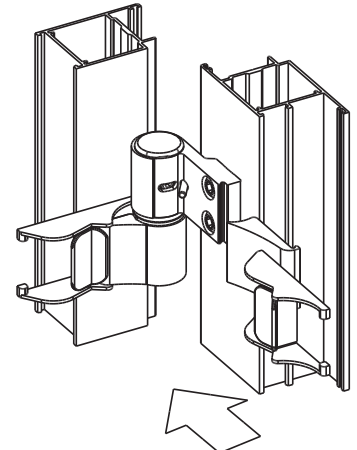

FRONTAL APPLICATION DOOR HINGES

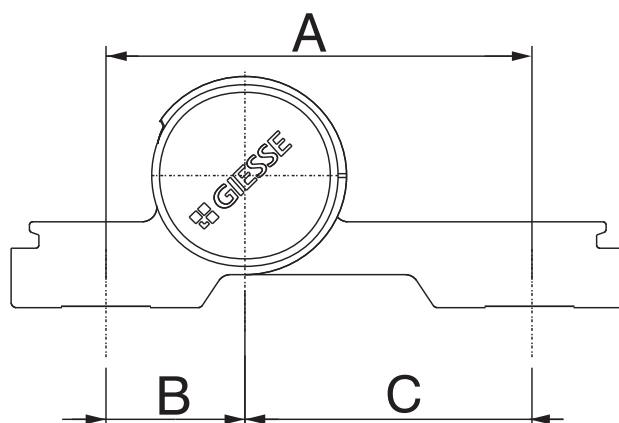

Item code	Description	Version	C/C distance A [mm]	B [mm]	C [mm]	Load capacity 2 hinges [kg]	Load capacity 3 hinges [kg]	CE marking	Base Raw	Anodised Elox	Painted	Trend/Gold Brass	Pieces per pack
06170	DOMINA CLASSIC	2 leaf	62,5	20,5	42	120	140	Class 13	X	X	X	X	10
06171	DOMINA CLASSIC	3 leaf	62,5	20,5	42	160	180	Class 14	X	X	X		10
06172	DOMINA CLASSIC	2 leaf	70,5	20,5	50	100	120	Class 12	X	X	X		10
06173	DOMINA CLASSIC	3 leaf	70,5	20,5	50	120	140	Class 13	X	X	X		10
06174	DOMINA CLASSIC	2 leaf	78	20,5	57,5	100	120	Class 12	X	X	X		10
06175	DOMINA CLASSIC	3 leaf	78	20,5	57,5	120	140	Class 13	X	X	X		10
06176	DOMINA CLASSIC	2 leaf	84	42	42	100	120	Class 12	X	X	X		10
06177	DOMINA CLASSIC	3 leaf	84	42	42	120	140	Class 13	X	X	X		10
06178	DOMINA CLASSIC	2 leaf	92	42	50	80	100	Class 11	X	X	X		10
06179	DOMINA CLASSIC	3 leaf	92	42	50	100	120	Class 12	X	X	X		10
06180	DOMINA CLASSIC	2 leaf	99,5	42	57,5	80	100	Class 11	X	X	X		10
06181	DOMINA CLASSIC	3 leaf	99,5	42	57,5	100	120	Class 12	X	X	X		10
06168	INDUSTRIAL DOMINA CLASSIC	2 leaf	62,5	20,5	42	120	140	Class 13	X	X	X		20
06169	INDUSTRIAL DOMINA CLASSIC	3 leaf	62,5	20,5	42	160	180	Class 14	X		X		20

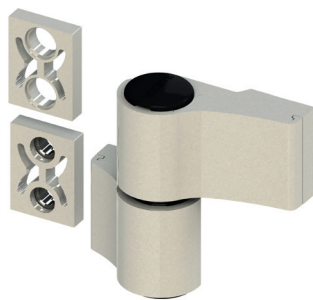

DOMINA HP HINGE

Functions

Surface mounting hinge, 2 or 3 wing version (Giese patent) for heavy doors made of aluminium.

Adjustable in three directions.

For combination with counterplate kit, with expansion dowels for single sealed unit profiles and with M12 direct fixing screw for thermal break profiles.

Online data sheet



Technical Features

Hinge suitable for doors subject to intensive use (use category 4* - heavy duty use) with high resistance to fatigue and wear (durability grade 7* - 200,000 test cycles). Ideal for the assembly of doors characterized by large dimensions, heavy weight and intensive use.

Adjustable in 3 directions with or without door installed:

- micrometric side adjustment (± 2.5 mm) with door installed, obtainable by turning the side adjustment screw located in the sash hinge cartridge. The locking grub screw on the sash hinge locks the side adjustment cartridge in the chosen position.

- compression micrometric adjustment (± 0.5 mm) obtainable by turning the bushing of the frame hinge (adjuster key art.05053). The locking grub screw, located on the frame hinge, locks the compression adjustment leaving access to the height adjustment.

- micrometric vertical adjustment (0/+4 mm), obtainable by turning the grub screw located at the bottom of the hinge. Insertion of the lower plug guarantees that the height adjustment is maintained.

The internal parts of the hinge are completely preassembled in two groups:

- pin cartridge for side adjustment
- cartridge with thrust bush for height and compression adjustments

Screw-cover plates fixed to hinge using pull screws driven from the inside, removable only with the sash open (tamper-proof).

For combination with counterplate kit, with expansion dowels for single sealed unit profiles and with M12 direct fixing screws for thermal break profiles.

Profile can be prepared with $\varnothing 11$ mm holes (for all fixing systems) using drill templates item 03237, item 05052 and item 03286 (for c/c distance 55.5).

When applied to a non-flush profile, the hinge is fitted in combination with shim steps selected according to the type of fixing used for the profile:

- steps with centering bushes: for counterplate kit and expansion dowels for single sealed unit profile

- steps without centering bushes: for M12 direct fixing screws.

* Complies with EN 1935

Materials

Extruded aluminium hinge bodies and screw-cover plates

Zamak pin cartridge and bush cartridge with GS Silver Plus finish (up to 500 h corrosion resistance)

$\varnothing 12$ pin, stainless steel

Side adjustment screw made of treated steel ensuring high resistance to corrosion

Thrust bush, acetal resin

Grub screws and vertical adjustment setscrew, stainless steel

Screw concealer plate fixing screws, zinc-coated steel

Polyamide concealer caps

Capacities

Up to 160 kg with two 2-wing hinges

Up to 180 kg with three 2-wing hinges

Up to 180 kg with two 3-wing hinges

Up to 200 kg with three 3-wing hinges

CE Mark in compliance EN1935

FRONTAL APPLICATION DOOR HINGES

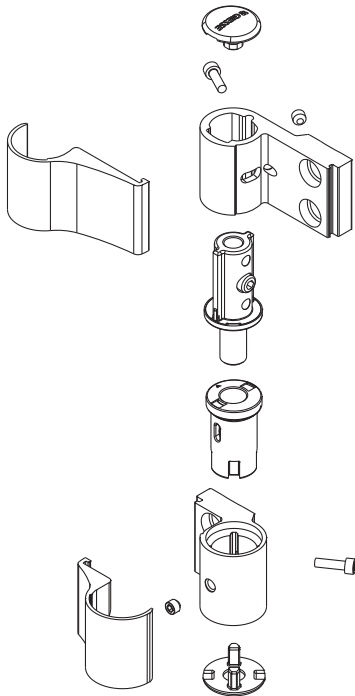

Preparation of profile for two-leaf hinge

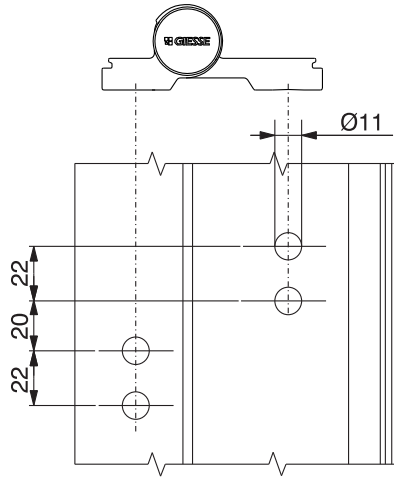

Machining on profile for three-wing hinge

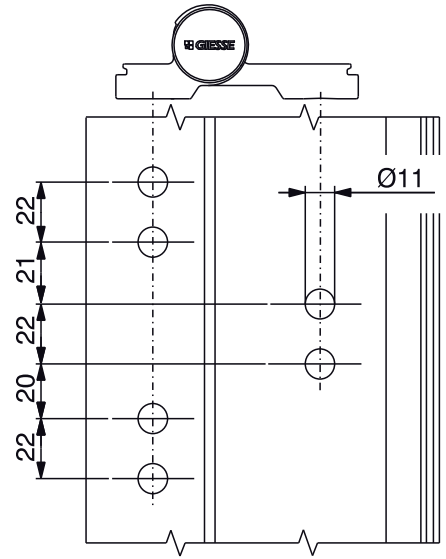

Height adjustment

Side adjustment

Compression adjustment

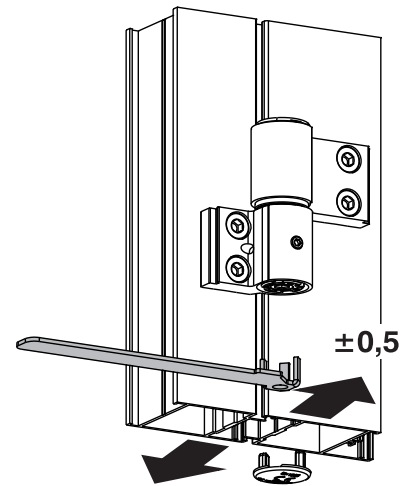
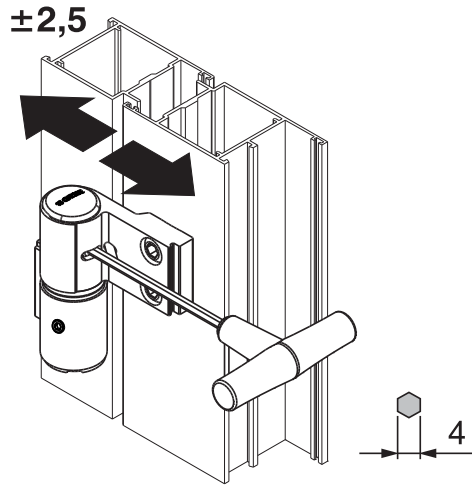
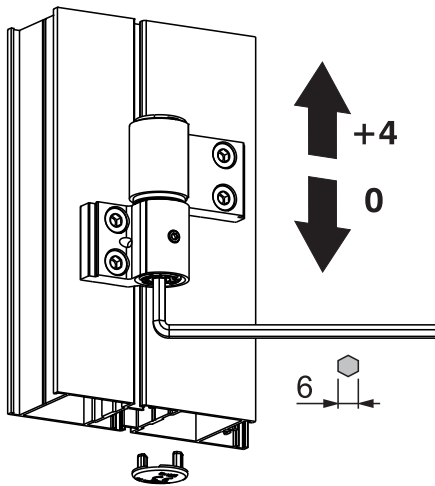

Steps with bushes

Steps without bushes

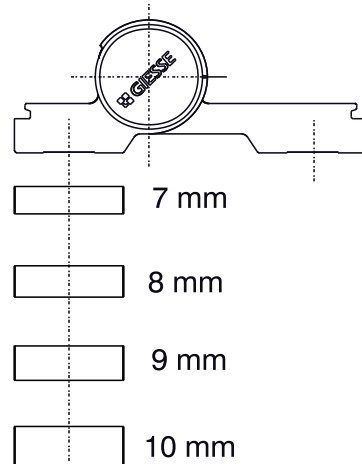
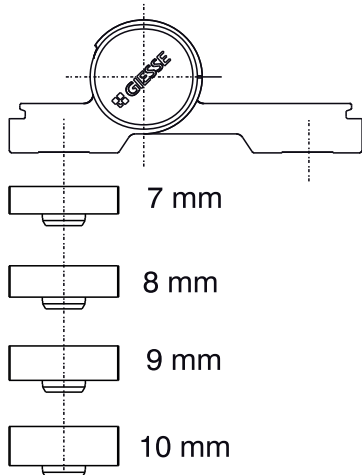

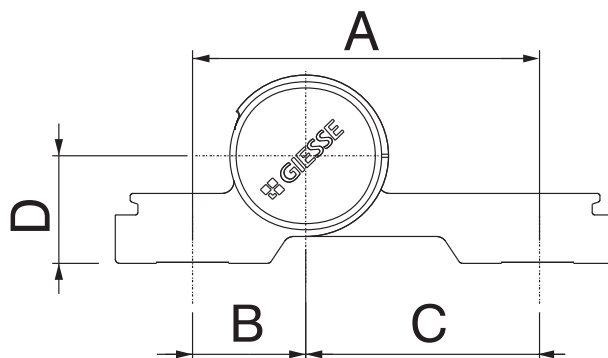

Item code	Description	Version	C/C distance A [mm]	B [mm]	C [mm]	Lift D [mm]	Load capacity 2 hinges [kg]	Load capacity 3 hinges [kg]	CE marking	Base Raw	Anodised Elox	Painted	Trend/Gold Brass	Pieces per pack
05158V	DOMINA HP	2 leaf	55,5	13,5	42		120	140	Class 12	X	X	X		10
05159V	DOMINA HP	2 leaf	55,5	13,5	42	28	120	140	Class 12	X	X	X		10
05160V	DOMINA HP	2 leaf	62,5	20,5	42		160	180	Class 14	X	X	X	X	10
05161V	DOMINA HP	3 leaf	62,5	20,5	42		180	200	Class 14	X	X	X	X	10
05162V	DOMINA HP	2 leaf	70,5	20,5	50		120	140	Class 13	X	X	X	X	10
05163V	DOMINA HP	3 leaf	70,5	20,5	50		140	160	Class 12		X	X	X	10
05164V	DOMINA HP	2 leaf	78	20,5	57,5		120	140	Class 13	X	X	X	X	10
05165V	DOMINA HP	3 leaf	78	20,5	57,5		140	160	Class 12		X	X	X	10
05166V	DOMINA HP	2 leaf	84	42	42		120	140	Class 13	X	X	X	X	10
05167V	DOMINA HP	3 leaf	84	42	42		140	160	Class 12	X	X	X	X	10
05168V	DOMINA HP	2 leaf	92	42	50		100	120	Class 12	X	X	X	X	10
05169V	DOMINA HP	3 leaf	92	42	50		120	140	Class 12		X	X	X	10
05170V	DOMINA HP	2 leaf	99,5	42	57,5		100	120	Class 12	X	X	X		10
05171V	DOMINA HP	3 leaf	99,5	42	57,5		120	140	Class 12	X	X	X		10
05172V	DOMINA HP	2 leaf	62,5	20,5	42	36	160	180	Class 13	X	X	X		10
05174V	DOMINA HP	2 leaf	62,5	20,5	42	27	160	180	Class 13	X	X	X		10
05175V	DOMINA HP	3 leaf	62,5	20,5	42	27	180	200	Class 14	X	X	X		10
05176V	DOMINA HP	2 leaf	62,5	20,5	42	28	160	180	Class 13	X	X	X		10
05178V	DOMINA HP	2 leaf	62,5	20,5	42	30	160	180	Class 13	X	X	X		10
05179V	DOMINA HP	3 leaf	62,5	20,5	42	30	180	200	Class 14	X	X	X		10



DOMINA HP HINGE, CORNER

Functions

Surface mounting corner hinge, 2-wing version for heavy doors made of aluminium.

Adjustable in three directions.

For combination with counterplate kit, with expansion dowels for single-groove profiles and with M12 direct fixing screw for thermal break profile (sash side only).

Online data sheet



Technical Features

Hinge suitable for doors subject to intensive use (use category 4* - heavy duty use) with high resistance to fatigue and wear (durability grade 7* - 200,000 test cycles). Ideal for the assembly of doors characterized by large dimensions, heavy weight and intensive use.

Adjustable in 3 directions with or without door installed:

- micrometric side adjustment (± 2.5 mm) with door installed, obtainable by turning the side adjustment screw located in the sash hinge cartridge. The locking grub screw, located on the sash hinge, locks the side adjustment cartridge in the chosen position.

- compression micrometric adjustment (± 0.5 mm), obtainable by turning the bushing of the frame hinge (adjuster key art.05053). The special plug locks the compression adjustment, leaving access to the height adjustment.

- micrometric vertical adjustment (0/+4 mm), obtainable by turning the grub screw located at the bottom of the frame part of the hinge

The frame hinge component is equipped with centering bushes.

The internal parts of the hinge are completely preassembled in two groups:

- pin cartridge for side adjustment
- cartridge with thrust bush for height and compression adjustments

The screw concealer plate of the frame hinge leaf cannot be removed from the outside and the screw concealer plate of the sash hinge leaf is secured by a pull screw driven from the inside, likewise removable only with the sash open (tamper-proof).

The hinge can be combined with counterplate kit, with expansion dowels for single sealed unit profiles and with M12 direct fixing screws for thermal break profiles.

Profile can be prepared with $\varnothing 11$ mm holes (for all fixing systems) using drill template item 05050.

The hinge is supplied with two M8 screws of dissimilar length that replace those supplied with the kit selected for fixing to the frame profile.

The locking clip, item 05051, facilitates the operation of fixing the screw-cover plates to the hinge.

* Complies with EN 1935

Materials

Extruded aluminium hinge bodies and screw-cover plates

Zamak pin cartridge and eccentric bush cartridge with GS Silver Plus finish (up to 500 h corrosion resistance)

$\varnothing 12$ pin, stainless steel

Side adjustment screw made of treated steel ensuring high resistance to corrosion

Centering bushes, zinc-coated steel

Thrust bush, acetal resin

Grub screw and vertical adjustment setscrew, stainless steel

Polyamide concealer caps

Screw concealer plate fixing screws, zinc-coated steel

Capacities

120 kg with two hinges

140 kg with three hinges

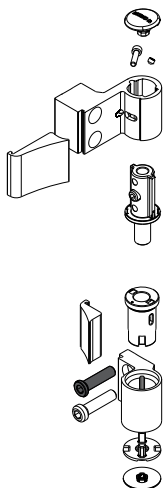

Machining on profile

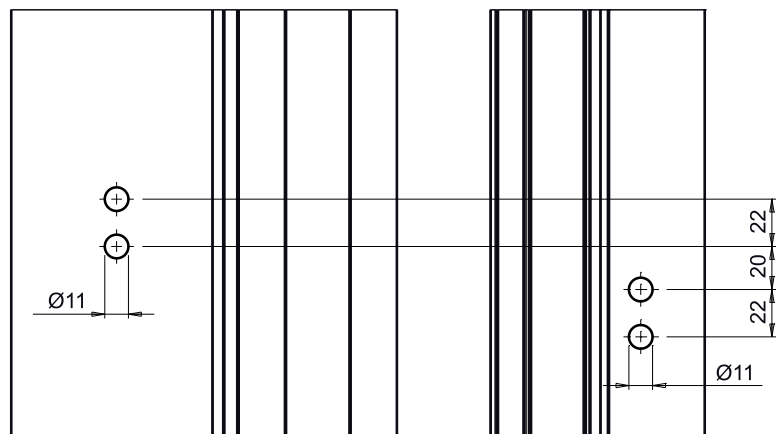

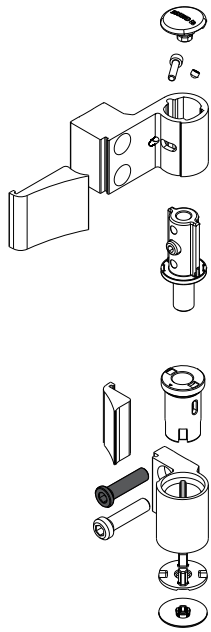

Machining on profile

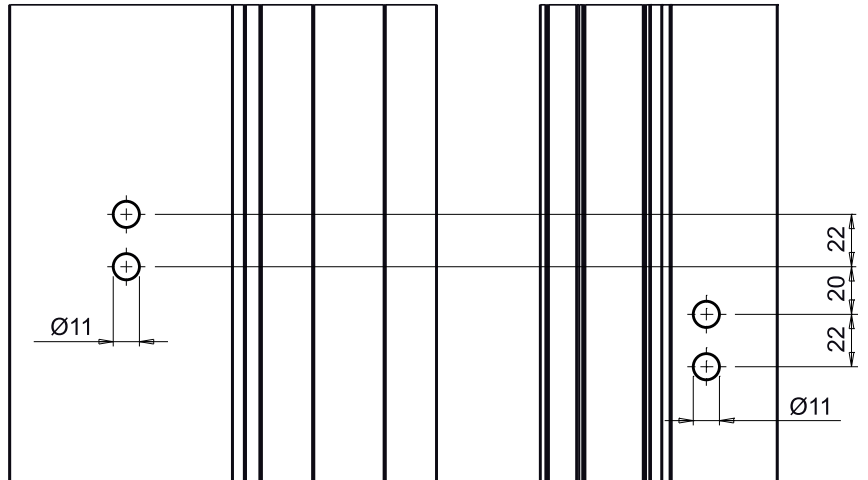

Side adjustment

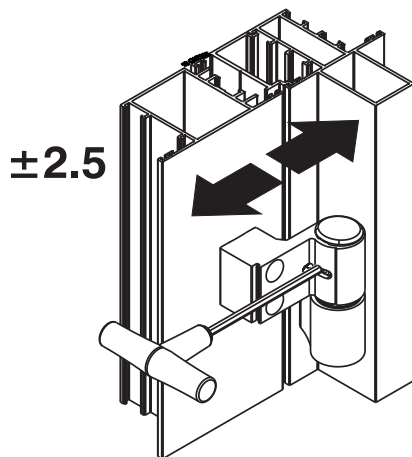

Height adjustment

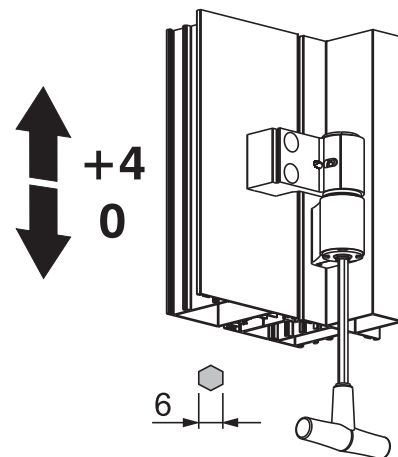

Compression adjustment

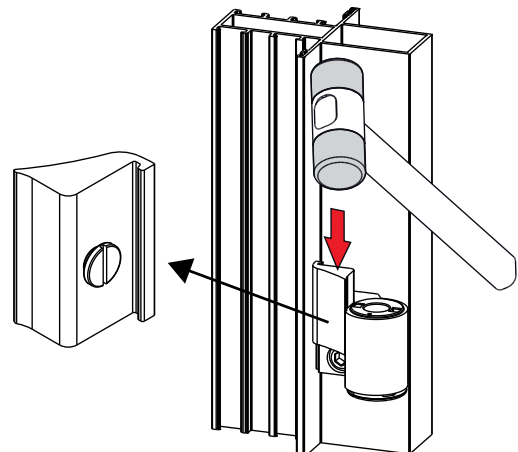
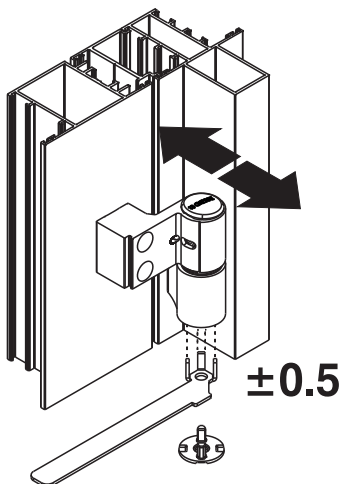

FRONTAL APPLICATION DOOR HINGES

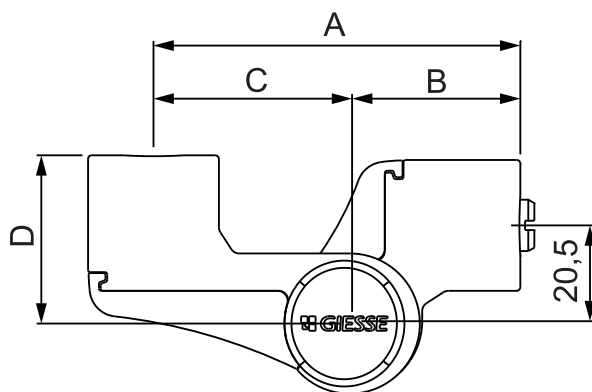

Item code	Description	Version	C/C distance A [mm]	B [mm]	C [mm]	Lift D [mm]	load capacity 2 hinges [kg]	load capacity 3 hinges [kg]	CE marking	Base Raw	Anodised Elox	Painted	Trend/Gold Brass	Pieces per pack
05180N	DOMINA HP CORNER	2 leaf	62,5	20,5	42		120	140	Class 13	X	X	X		10
05182N	DOMINA HP CORNER	2 leaf	78,5	36,5	42	36	120	140	Class 13		X	X		10



DOMINA HP HINGE, COVER

Functions

Surface mounting hinge, 2 or 3 wing version (Giesse patent) for heavy doors made of aluminium.

Adjustable in three directions.

For combination with paintable covers purchased separately.

For combination with counterplate kit, with expansion dowels for single sealed unit profiles and with M12 direct fixing screw for thermal break profiles.

Online data sheet



Technical Features

Hinge suitable for doors subject to intensive use (use category 4* - heavy duty use) with high resistance to fatigue and wear (durability grade 7* - 200,000 test cycles). Ideal for the assembly of doors characterized by large dimensions, heavy weight and intensive use.

Adjustable in 3 directions with or without door installed:

- micrometric side adjustment (± 2.5 mm) with door installed, obtainable by turning the side adjustment screw located in the sash hinge cartridge. The locking grub screw on the sash hinge locks the side adjustment cartridge in the chosen position.

- compression micrometric adjustment (± 0.5 mm) obtainable by turning the bushing of the frame hinge (adjuster key art.05053). The locking grub screw, located on the frame hinge, locks the compression adjustment leaving access to the height adjustment.

- micrometric vertical adjustment (0/+4 mm), obtainable by turning the grub screw located at the bottom of the frame hinge. Insertion of the lower plug guarantees that the height adjustment is maintained.

The internal parts of the hinge are completely preassembled in two groups:

- pin cartridge for side adjustment
- cartridge with thrust bush for height and compression adjustments

For combination with counterplate kit, with expansion dowels for single sealed unit profiles and with M12 direct fixing screws for thermal break profiles.

Profile can be prepared with $\varnothing 11$ mm holes (for all fixing systems) using drill templates item 03237 and item 05052.

The hinge does not have screw-cover plates and is used in combination with paintable covers (purchased separately), secured to the hinge by pull screws driven from the inside and removable only with the sash open (tamper-proof).

When applied to a non-flush profile, the hinge is fitted in combination with shim steps selected according to the type of fixing used for the profile:

- steps with centering bushes: for counterplate kit and expansion dowels for single sealed unit profile
- steps without centering bushes: for M12 direct fixing screws.

and to the relative extruded aluminium concealer which combines with the cover to encase the hinge completely.

* Complies with EN 1935

Materials

Hinge

Extruded aluminium hinge bodies, anodized black
Zamak pin cartridge and bush cartridge with GS Silver Plus finish (up to 500 h corrosion resistance)

$\varnothing 12$ pin, stainless steel

Side adjustment screw made of treated steel ensuring high resistance to corrosion

Thrust bush, acetal resin

Grub screws and vertical adjustment setscrew, stainless steel

Screw concealer plate fixing screws, zinc-coated steel

Polyamide concealer caps

Cover

Zamak covering for hinge

Cover for extruded aluminium shim steps

Hinge cover fixing screws, zinc-coated steel

Capacities

Up to 160 kg with two 2-wing hinges

Up to 180 kg with three 2-wing hinges

Up to 180 kg with two 3-wing hinges

Up to 200 kg with three 3-wing hinges

CE Mark in compliance EN1935

FRONTAL APPLICATION DOOR HINGES

Preparation of profiles for 2-wing hinge

Preparation of profiles for 3-wing hinge

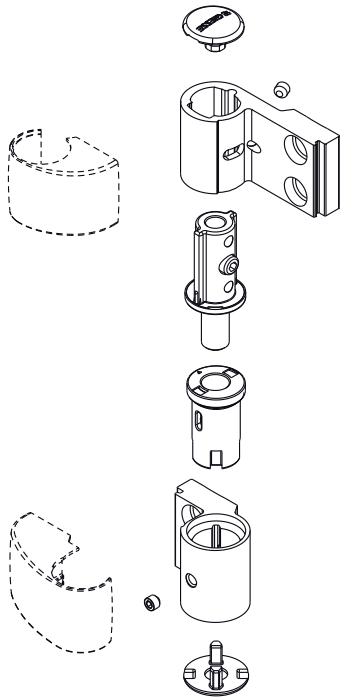

Height adjustment

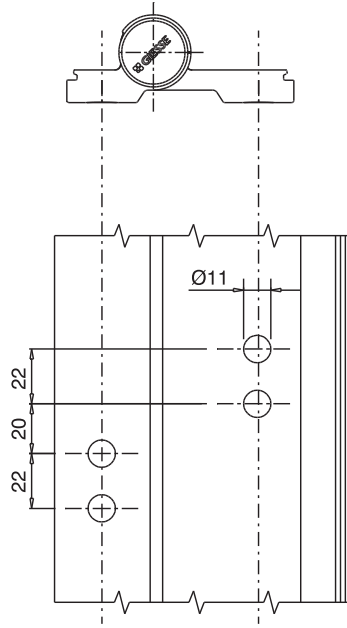

Side adjustment

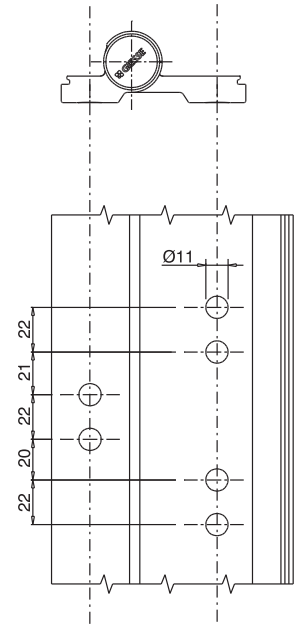

Compression adjustment

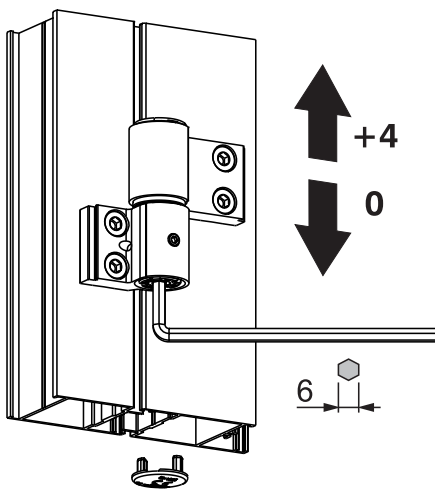

Steps with bushes

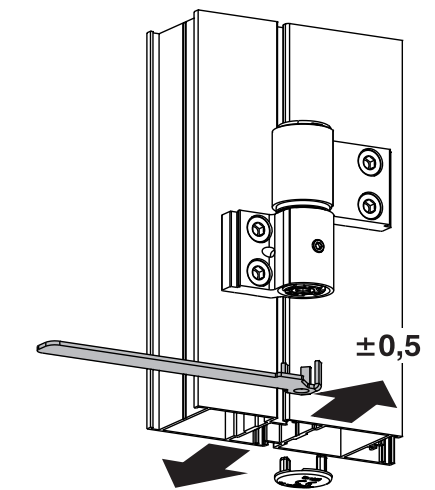
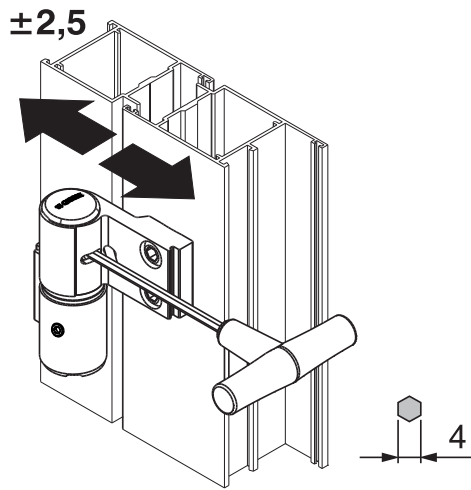

Steps without bushes

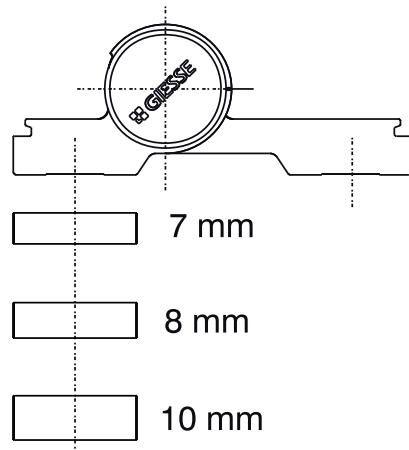
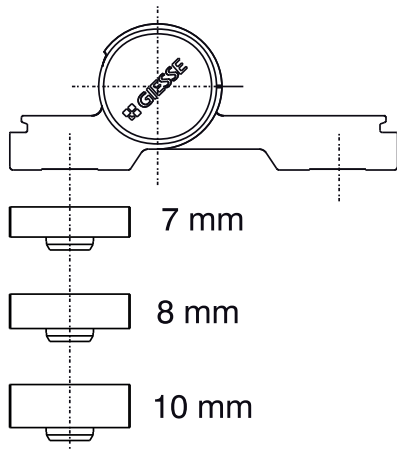

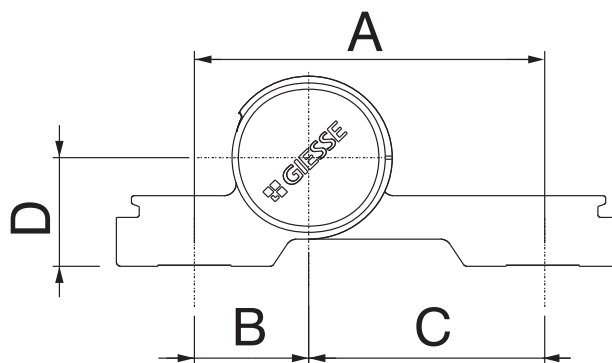

Item code	Description	COVER code	Version	C/C distance A [mm]	B [mm]	C [mm]	Lift D [mm]	Load capacity 2 hinges [kg]	Load capacity 3 hinges [kg]	CE marking	Base Raw	Anodised Elox	Painted	Trend/Gold Brass	Pieces per pack
05120V	DOMINA HP COVER	06120N	2 leaf	62,5	20,5	42		160	180	Class 14		X			10
05121V	DOMINA HP COVER	06121N	3 leaf	62,5	20,5	42		180	200	Class 14		X			10
05122V	DOMINA HP COVER	06122N	2 leaf	70,5	20,5	50		120	140	Class 13		X			10
05125V	DOMINA HP COVER	06125N	3 leaf	78	20,5	57,5		140	160	Class 12		X			10
05132V	DOMINA HP COVER	06132N	2 leaf	62,5	20,5	42	36	160	180	Class 13		X			10
05134V	DOMINA HP COVER	06134N	2 leaf	62,5	20,5	42	27	160	180	Class 13		X			10
05135V	DOMINA HP COVER	06135N	3 leaf	62,5	20,5	42	27	180	200	Class 14		X			10
05136V	DOMINA HP COVER	06136N	2 leaf	62,5	20,5	42	28	160	180	Class 13		X			10
05137V	DOMINA HP COVER	06137N	3 leaf	62,5	20,5	42	28	180	200	Class 14		X			10

FRONTAL APPLICATION DOOR HINGES

DOMINA STEPS

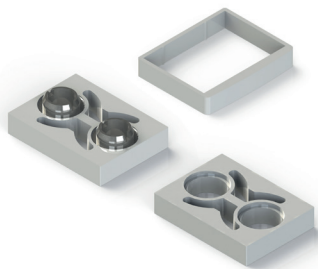

Functions

Steps for combination with DOMINA HP, DOMINA HP COVER and DOMINA CLASSIC hinges for application to non-flush profiles.

Online data sheet



Technical Features

Steps of 7, 8, 9, 10 and 12 mm height for combination with hinges of the DOMINA HP, DOMINA HP COVER and DOMINA CLASSIC range, flush version, designed to compensate for the step in the profile.

Compatible with C/C distances starting from 62,5mm.

Available in two versions:

- with centering bushes, used in combination with counterplate kit and expansion dowels for single sealed unit profiles
- without centering bushes, designed to accept M12 direct fixing screw for thermal break profile

The step, when used in combination with the Cover version hinge, is finished with the relative step concealer.

Materials

Extruded aluminium step

Centering bushes, zinc-coated steel; hinge bodies and screw-cover plates, extruded aluminium

Extruded aluminium cover

Step with bushes

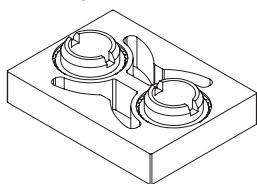

Step without bushes

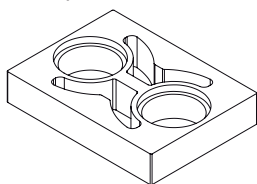

Step cover

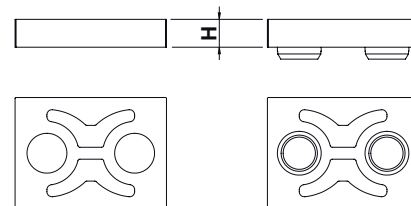
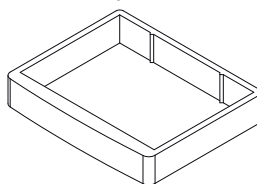

Item code	Description	H [mm]	Hinges HP	Hinges COVER	Hinges CLASSIC	Fixing with M12 screw	Fixing with Counterplate	Fixing with Expansion dowels	Base Raw	Anodised Elox	Painted	Trend/Gold Brass	Pieces per pack
05095	STEP 7 WITHOUT BUSHES	7	x	x	x	x			X	X	X		10
05096	STEP 8 WITHOUT BUSHES	8	x	x	x	x			X	X	X		10
05097	STEP 10 WITHOUT BUSHES	10	x	x	x	x			X	X	X		10
05098	STEP 9 WITHOUT BUSHES	9	x		x	x			X	X	X		10
05195	STEP 7 WITH BUSHES	7	x	x	x		x	x	X	X	X	X	10
05196	STEP 8 WITH BUSHES	8	x	x	x		x	x	X	X	X	X	10
05197	STEP 10 WITH BUSHES	10	x	x	x		x	x	X	X	X	X	10
05198	STEP 9 WITH BUSHES	9	x	x	x		x	x	X	X	X	X	10
05199	STEP 12 WITH BUSHINGS	12	x				x	x	X		X		10
06195N	COVER STEP COVER	7		x							X		10
06196N	COVER STEP COVER	8		x							X		10

COUNTERPLATE KIT

Functions

Counterplate inserted in the hollow section of the tubular profile for fixing Domina HP, Domina HP Cover and Domina Classic hinges.

Online data sheet



Technical Features

Available in version for 2 and 3 wing hinge, flush and with step, the kit comprises:

- two extruded aluminium fixing plates size 15x20 mm can be used on both sides to allow the greatest possible number of applications
- retaining springs
- M8x28 fixing screws with special hexagon head

When fitting the hinge with counterplates, the profile must be prepared by drilling a $\varnothing 11$ mm hole with the aid of machining templates item 03237, item 05052, item 03286 (specifically for c/c distance 55.5) and item 05050 (specifically for corner hinges).

The frame mounted fixing plate of the 3-leaf version is longer than the plate supplied with the 2-leaf version, so that both of the two leaves can be secured using just the one component.

Materials

Extruded aluminium fixing plates
Retaining springs made of spring steel
Fixing screws, zinc-coated steel

Two-wing version

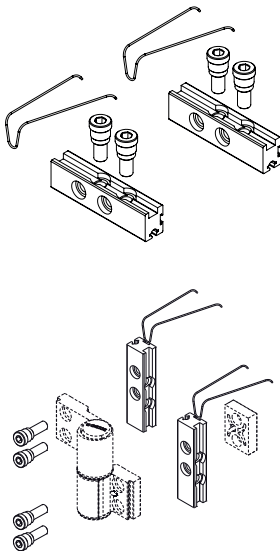

Three-wing version

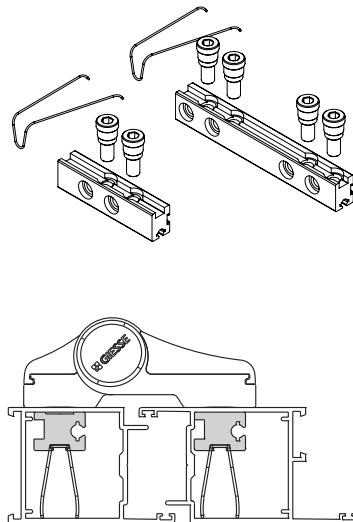

Application to profile

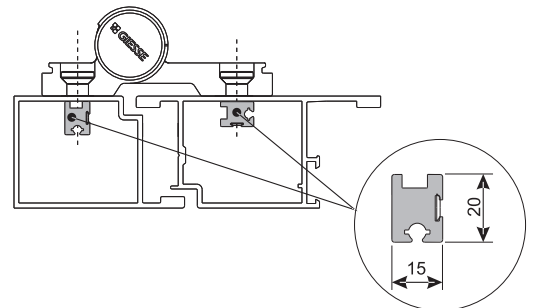

Item code	Description	Version	Base Raw	Anodised Elox	Painted	Trend/Gold Brass	Pieces per pack
0520001	COUNTERPLATE KIT	for 2-wing hinge	X				10
0520101	COUNTERPLATE KIT	for 3-wing hinge	X				10
0520201	COUNTERPLATE KIT	for 2-wing hinge with step	X				10
0520301	COUNTERPLATE KIT	for 3-wing hinge with step	X				10

FRONTAL APPLICATION DOOR HINGES

DIRECT FIXING SCREWS



Functions

M12 screw for direct fixing of DOMINA HP, DOMINA HP COVER and DOMINA CLASSIC hinges to thermal break profiles.

Online data sheet



Technical Features

Using the M12 direct fixing screw, DOMINA HP, DOMINA HP COVER and DOMINA CLASSIC hinges can be fitted to thermal break type profiles without using counterplates located internally of the hollow section (*).

Available in four different lengths:

W = 55 mm

W = 65 mm

W = 75 mm

W = 90 mm

When fitting hinges with the direct fixing screw, the profile must be prepared by drilling a $\varnothing 11$ mm hole with the aid of machining templates item 03237, item 05052 and item 05050 (specifically for corner hinges).

(*) Except for Domina HP and Domina HP Cover hinge, c/c distance 55.5

Materials

Zinc-coated steel fixing screw

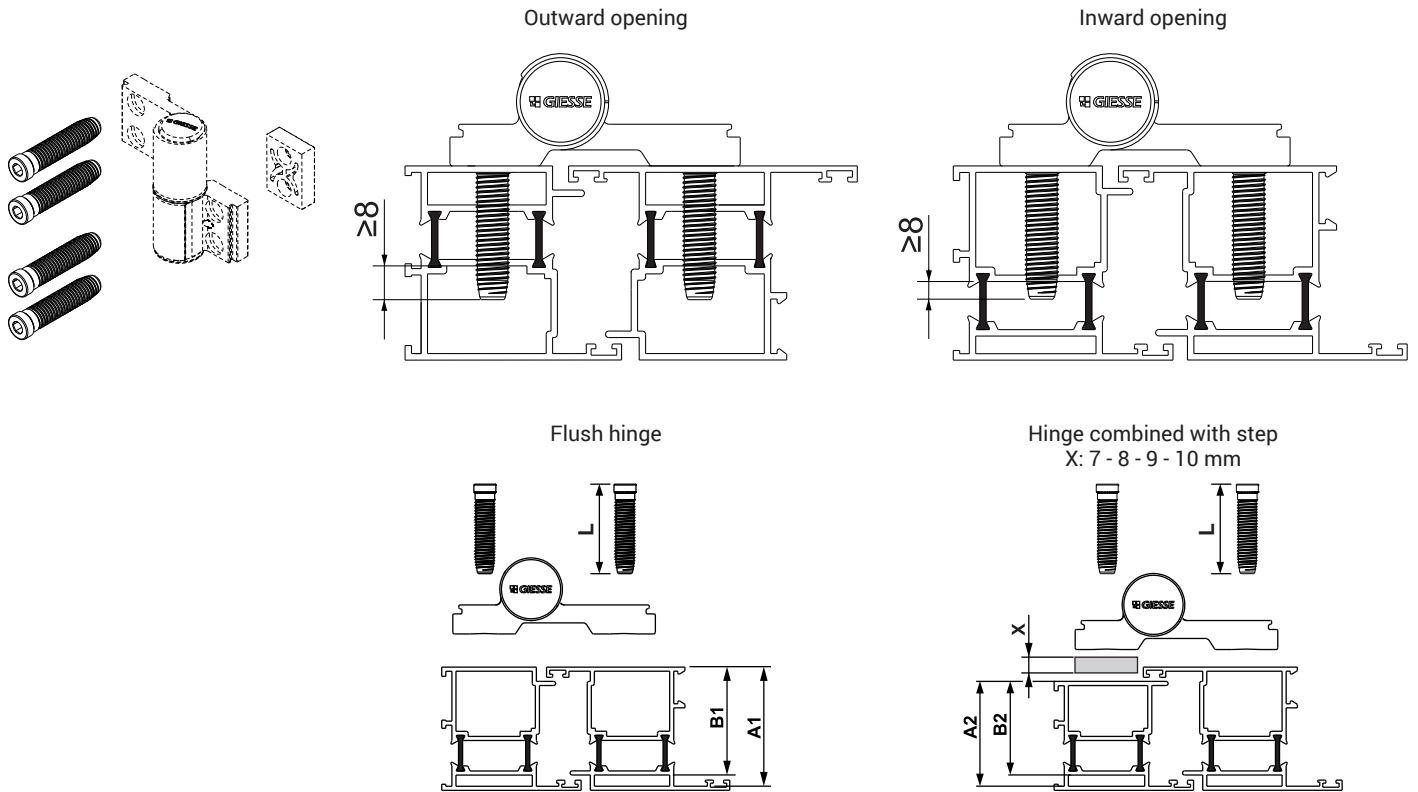

Item code	Description	L [mm]	A1 [mm]	B1 [mm]	A2 [mm]	B2 [mm]	Base Raw	Anodised Elox	Painted	Trend/Gold Brass	Pieces per pack
05300	DIRECT FIXING SCREW M12x55	55	≥ 42	≤ 34	$\geq 42-X$	$\leq 34-X$	X				20
05301	DIRECT FIXING SCREW M12x65	65	≥ 52	≤ 44	$\geq 52-X$	$\leq 44-X$	X				20
05302	DIRECT FIXING SCREW M12x75	75	≥ 62	≤ 54	$\geq 62-X$	$\leq 54-X$	X				20
05303	DIRECT FIXING SCREW M12x90	90	≥ 77	≤ 69	$\geq 77-X$	$\leq 69-X$	X				20

EXPANSION DOWELS



Functions

Expansion dowels for rapid fixing of DOMINA HP, DOMINA HP COVER and DOMINA CLASSIC hinges to profile without thermal break.

Online data sheet



Technical Features

Fixing system for Domina HP, HP Cover and Domina Classic hinges comprising plug, special expansion bush to be located at the holes of the hinge leaf, and M8 screw with special socket head driven by hex key (*).

When fitting plugs, the profile must be prepared by drilling a Ø11 mm hole with the aid of machining templates item 03237, item 05052 and item 05050 (specifically for corner hinges).

(*) Except for HP, HP Cover and Classic hinge, c/c distance 55.5.

Materials

Plug and screw with special head, zinc-coated steel

Expansion bush, zamak

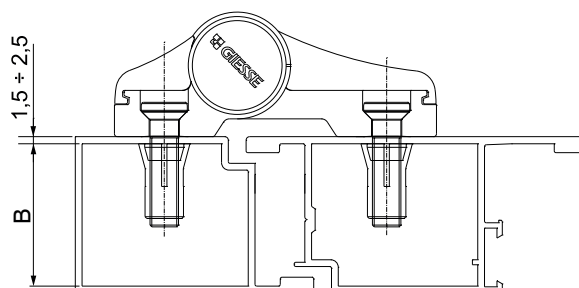
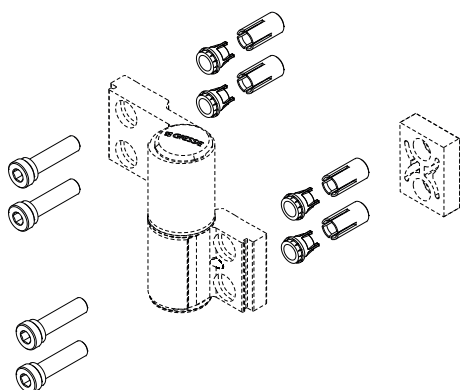

Item code	Description	B [mm]	Base Raw	Anodised Elox	Painted	Trend/Gold Brass	Pieces per pack
0520401	EXPANDING PLUG FOR single sealed unit PROFILE - DOMINA HP, DOMINA HP COVER AND DOMINA CLASSIC FLUSH/ONE-PIECE	≥ 30	X				20
0520501	EXPANDING PLUG FOR single sealed unit PROFILE - DOMINA HP, DOMINA HP COVER AND DOMINA CLASSIC WITH STEP	≥ 30	X				20

TT PROFILE SPACERS



Functions

Telescopic spacers for assembly of DOMINA HP, DOMINA HP COVER and DOMINA CLASSIC hinges in combination with counterplate kit, for fixing to thermal break profiles with outward opening.

Online data sheet



Technical Features

To fit spacers, the holes on the external part of the profile must be enlarged from $\varnothing 11$ mm to $\varnothing 15$ mm with the aid of drill bit item 03238.

Each spacer is supplied together with 2 screws of length as specified in the table.

The range comprises four items differing one from another in terms of their adjustment range (see table).

Materials

Bush for spacer, telescopic screw and M8 screw with special head, zinc-coated steel

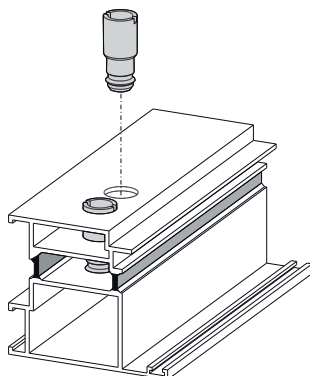
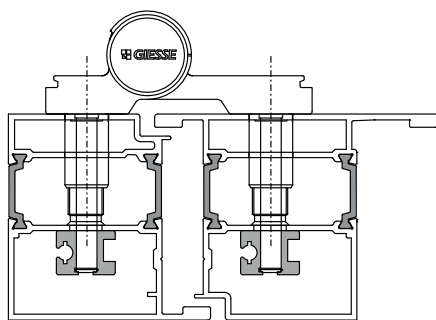

Adjustment range

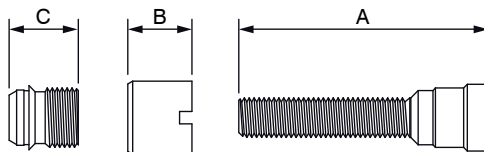
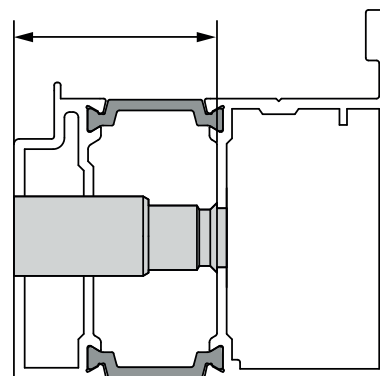

Item code	Description	Adjustment range	A [mm]	B [mm]	C [mm]	Screws included	Base Raw	Anodised Elox	Painted	Trend/Gold Brass	Pieces per pack
0323901	TELESCOPIC SPACER 13 -18.5 mm	13÷18.5 mm	50	13	14	M8x50	X				20
0324001	TELESCOPIC SPACER 18.5 -29 mm	18.5÷29 mm	60	18,5	29	M8x60	X				20
0324101	TELESCOPIC SPACER 29 -40 mm	29÷40 mm	70	29	40	M8x70	X				20
0324201	TELESCOPIC SPACER 29 -50 mm	29÷50 mm	80	29	50	M8x80	X				20



DOMINA HP SECURITY SYSTEM



Functions

Security system for DOMINA HP and DOMINA HP COVER front-mounting hinges.

Online data sheet



Technical Features

The SKG security system makes it possible to create outward opening doors with SKG 2-star or 3-star certification depending on the number of hinges used.

The burglar-proof kit, which is compatible with counterplates and M12 direct screws for fixing hinge to profile, is available in versions for two-wing and three-wing hinges.

Burglar-proof kit for two-wing hinge, composed of:

- no. 1 side adjustment cartridge with steel pin offering elevated cutting and corrosion resistance, to be used to replace the cartridge supplied with the hinge
- no. 2 supports with stainless steel balls to be inserted in the seat of the hinge to profile fixing screws

Burglar-proof kit for three-wing hinges, composed of:

- no. 2 steel half-pins offering elevated cutting and corrosion resistance, to be used to replace the half-pins of the side adjustment cartridge supplied with the hinge
- no. 3 supports with stainless steel balls to be inserted in the seat of the hinge fixing screws in outward opening applications

The burglar-proof kit must be used in conjunction with SKG class 2 (2-star) or class 3 (3-star) plugs to replace the standard plugs supplied with the hinge, depending on the chosen configuration.

The SKG 2-star plug is used on doors with 2 hinges (2 or 3 wings) equipped with burglar-proof balls; the SKG 3-star plug is used in the case of doors with 3 hinges (2 or 3 wings) equipped with burglar-proof balls.

Materials

Stainless steel burglar-proof balls
 Balls support in polyamide
 Steel pins with treatment providing elevated cutting and corrosion resistance
 SKG plugs in polyamide



Article 05241

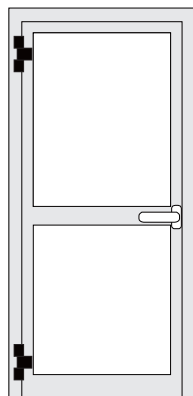
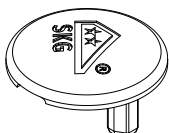

Article 05242

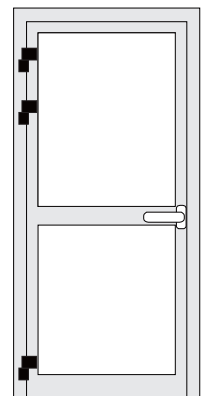
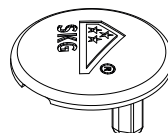

FRONTAL APPLICATION DOOR HINGES

Article 05243 (set 2 leaf)

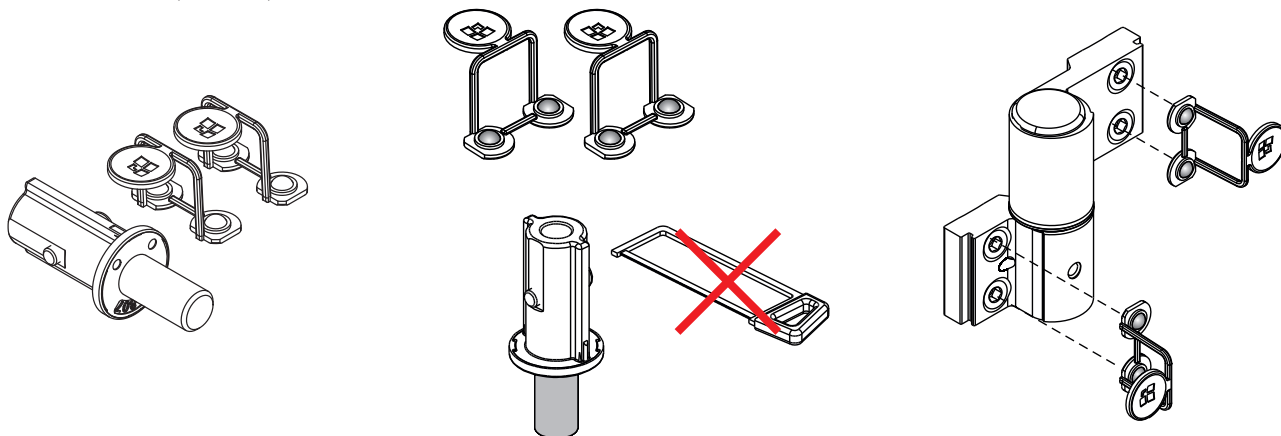

Article 05244 (set 3 leaf)

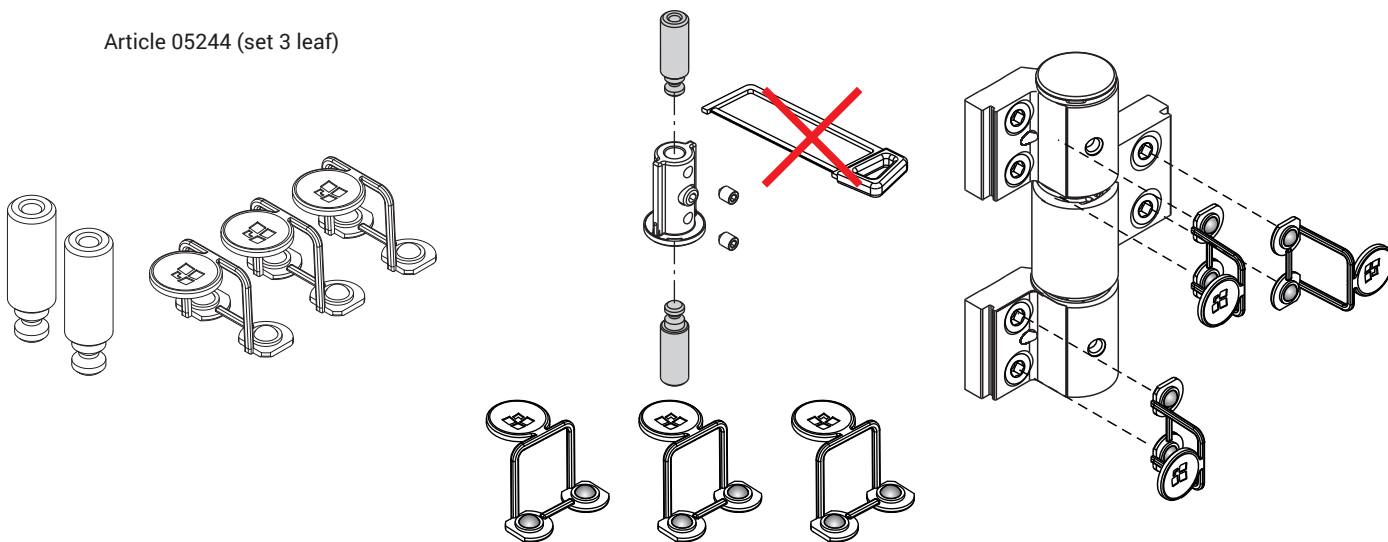

Item code	Description	Compatible with counter-plates kit	Compatible with direct fixing M12 screws	Compatible with spacers	Base Raw	Anodised Elox	Painted	Trend/Gold Brass	Pieces per pack
05241	SKG 2 STAR PLUGS	-	-	-	X				40
05242	SKG 3 STAR PLUGS	-	-	-	X				40
05243	SKG 2-WING BURGLAR-PROOF KIT	0520001-0520101-0520201-0520301	05300-05301-05302-05303	0323901-0324001-0324101-0324201	X				10
05244	SKG 3-WING BURGLAR-PROOF KIT	0520001-0520101-0520201-0520301	05300-05301-05302-05303	0323901-0324001-0324101-0324201	X				10

HINGE MACHINING TEMPLATES

Functions

Profile machining templates for assembly of DOMINA HP, DOMINA HP COVER and DOMINA CLASSIC hinges, in 2 and 3 leaf versions and with the various c/c distances.

Online data sheet

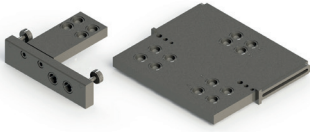

Technical Features

Templates are provided with dowel pins of different diameters, to facilitate positioning on flush profiles, and with adjustable positioning aids for application to non-flush profiles.

Materials

Aluminium template
Carbon nitrided steel guide bushes (preassembled)
Dowel pins, positioners and fixing screws, all zinc-coated steel

Machining template code 03237

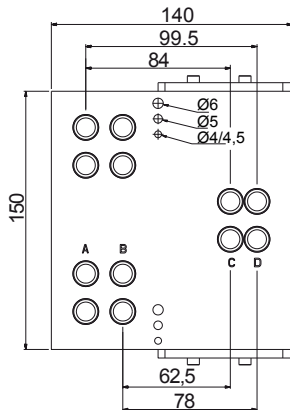
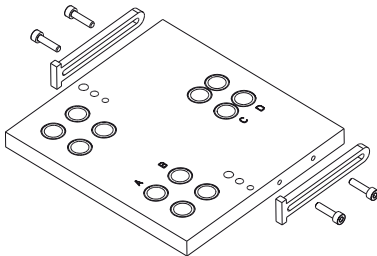

Machining template code 05050

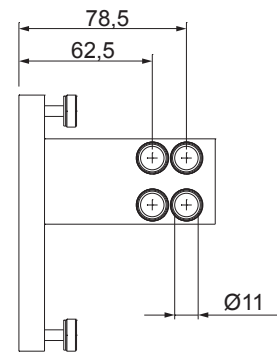
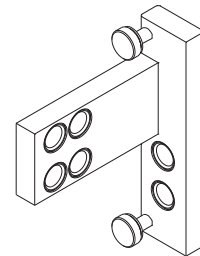

Item code	Description	C/C distance [mm]	Parts	Base Raw	Anodised Elox	Painted	Trend/Gold Brass	Pieces per pack
03237	MACHINING TEMPLATE FOR DOMINA HINGES	62,5 78 84 99,5	adjustable positioners no.2 dual diameter pins $\varnothing 4\text{-}\varnothing 4.5$ no.2 pins $\varnothing 5$ no.2 pins $\varnothing 6$	X				1
05052	MACHINING TEMPLATE FOR DOMINA HINGES	70,5 92	adjustable positioners no.2 dual diameter pins $\varnothing 4\text{-}\varnothing 4.5$ no.2 pins $\varnothing 5$ no.2 pins $\varnothing 6$	X				1

DOMINA ASSEMBLY EQUIPMENT

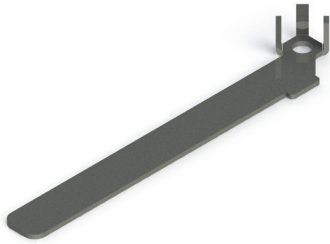

Functions

Equipment for installation and adjustment of clamp door hinges and front-fitting hinges.

Online data sheet



05051

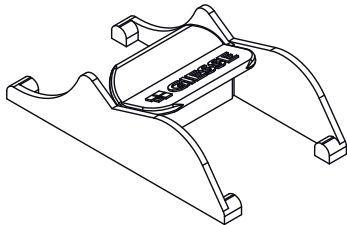

03900

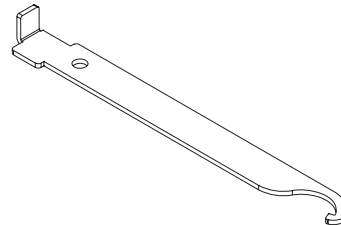

05054

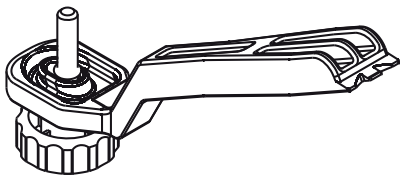

05053

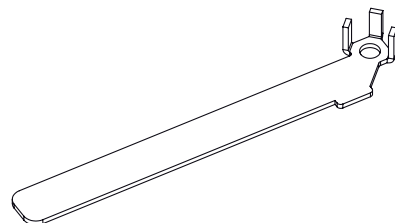

Item code	Description	Note	Base Raw	Anodised Elox	Painted	Trend/Gold Brass	Pieces per pack
03900	DOOR HINGE ADJUSTER KEY		X				5
05053	DOMINA HP ADJUSTER KEY		X				10
05054	PIN EXTRACTOR - DOMINA HP 3 LEAF		X				1

CHIC DOOR 160 HINGE

Functions

Reversible door hinge, to be applied inside the profiles for complete invisibility when the door is closed and adjustable in three directions (width, height and compression).

Online data sheet



Technical Features

Hinge with concealed installation, suitable for aluminium doors, even of large size, which meet most of the residential, commercial and public applications. An innovative system (patented) makes hinge installation and sash to frame coupling easier, even in the case of doors installed in architectural stack. Reduced profile machining and functional fixing devices on the hinge facilitate the doors production, reducing their production times.

CHIC Door is adjustable in three directions:

- Side adjustment (+/- 3 mm), using an Allen key on the hinge adjusters.
- Height adjustment (- 2 /+ 3 mm), using an Allen key on the adjustment screw.
- Compression adjustment (+/- 1 mm), obtainable by turning the screws on the sash hinge body.

Hinge tested in compliance with EN1935.

Compulsory: opening limiter.

Materials

Extruded aluminium hinge bodies and upright
Main pin in white anodised turned aluminium
Bases and anchors in sealed white galvanised zamak

Axial bearing, adjustment plate and secondary stainless steel pins
Extruded aluminium fixing plates
Stainless steel screws and spring
Hostaform bushing
POM template

Capacities

160 kg with 2 hinges

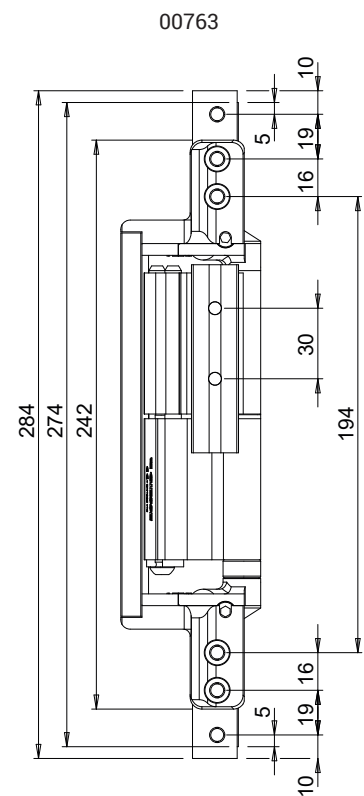
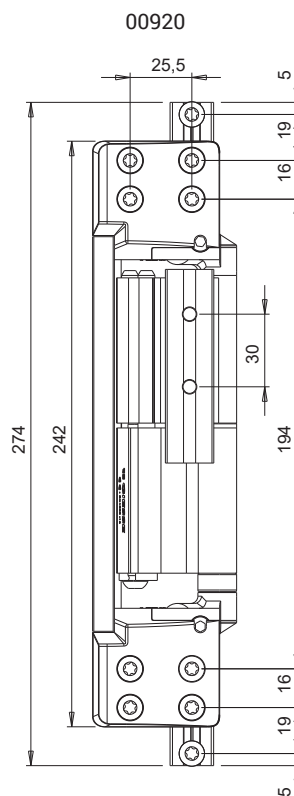
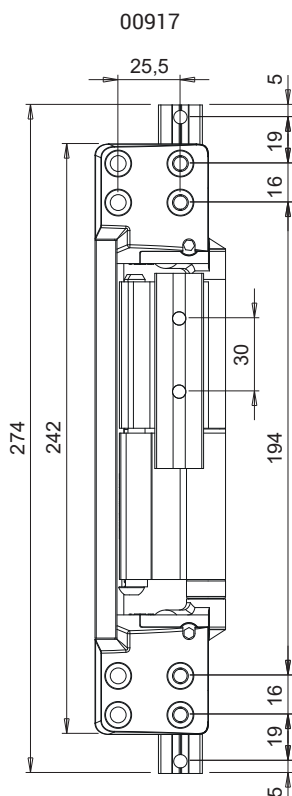

00917

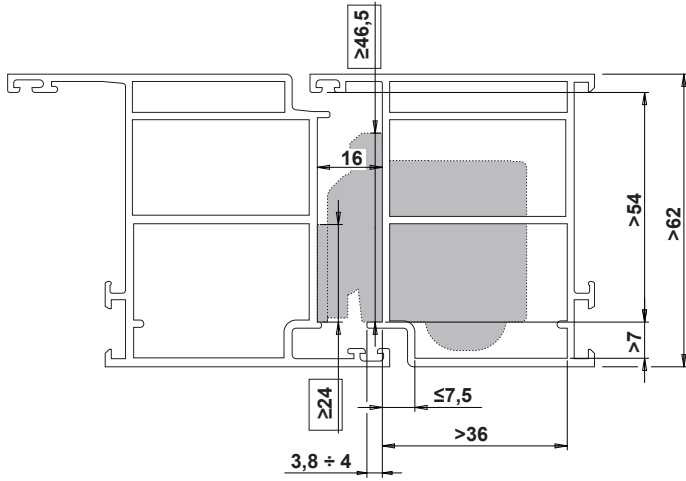

00920

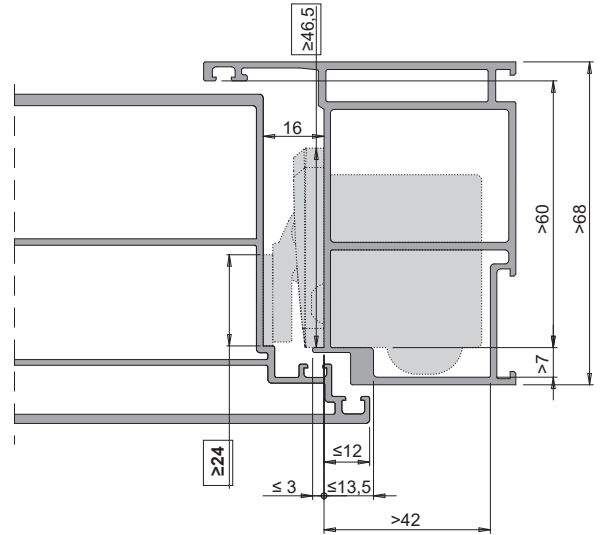

00763

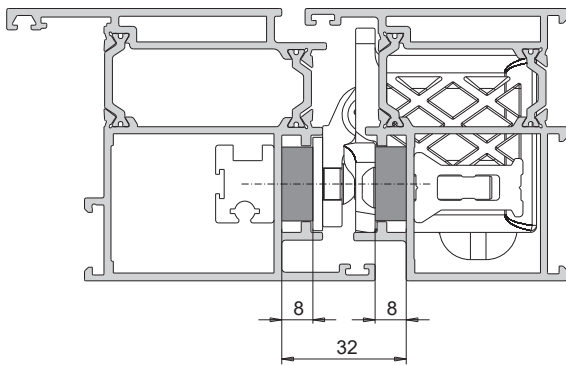

Height adjustment

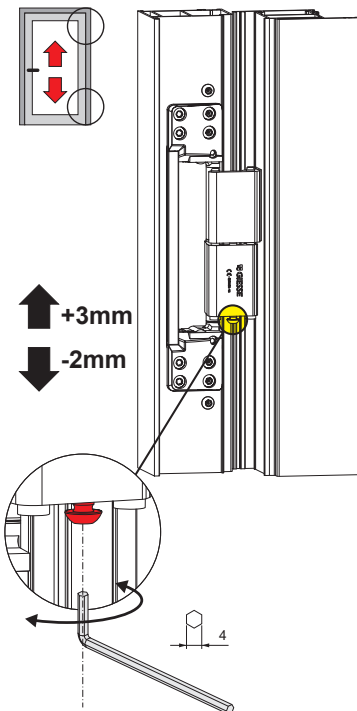

Side adjustment

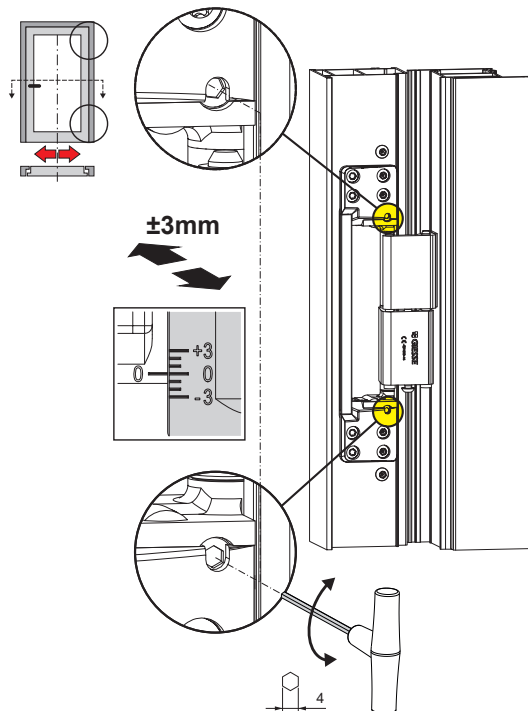

Compression adjustment

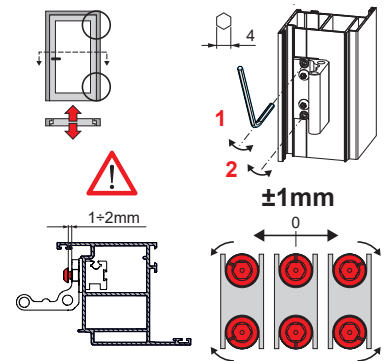

CONCEALED HINGES FOR DOOR

00757

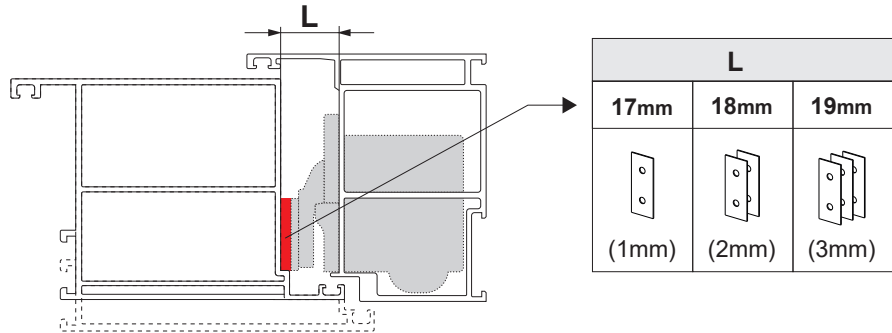
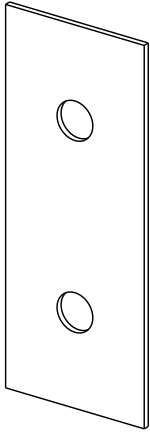

Item code	Description	Version	Load capacity 2 hinges [kg]	Height adjustment	Side adjustment	Compression adjustment	Base Raw	Anodised Elox	Painted	Trend/Gold Brass	Pieces per pack
00917	FLUSH CHIC DOOR 160 HINGE	RH (reversible)	160	+3 / -2 mm	±3 mm	±1 mm		X			1
00920	OVERLAP CHIC DOOR 160 HINGE	RH (reversible)	160	+3 / -2 mm	±3 mm	±1 mm		X			1
00763	FLUSH CHIC DOOR CTZ HINGE	RH (reversible)	160	+3 / -2 mm	+2 / -3 mm	±1 mm		X			1
00757	THICKNESS 1 mm CHIC DOOR HINGE	-	-	-	-	-	X				50

CHIC DOOR REINFORCEMENT KIT

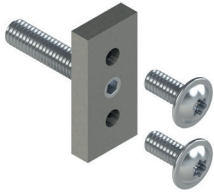

Functions

Reinforcement kit for fixing the CHIC Door 160 hinge when used on profiles with a thickness less than 1.8 mm.

Online data sheet



Technical Features

Reinforcement kit to be combined with the CHIC Door 160 hinge to make the hinge fixing more stable when the profiles thickness is less than 1.8 mm. Using the Kit on profiles with thickness from 1.6 to 1.8 mm allows to maintain the hinge load capacity performance unchanged. For application details refer to the fitting instructions made available with the CHIC Door 160 hinge.

Materials

Extruded aluminium plate
Stainless steel screws and grub screw

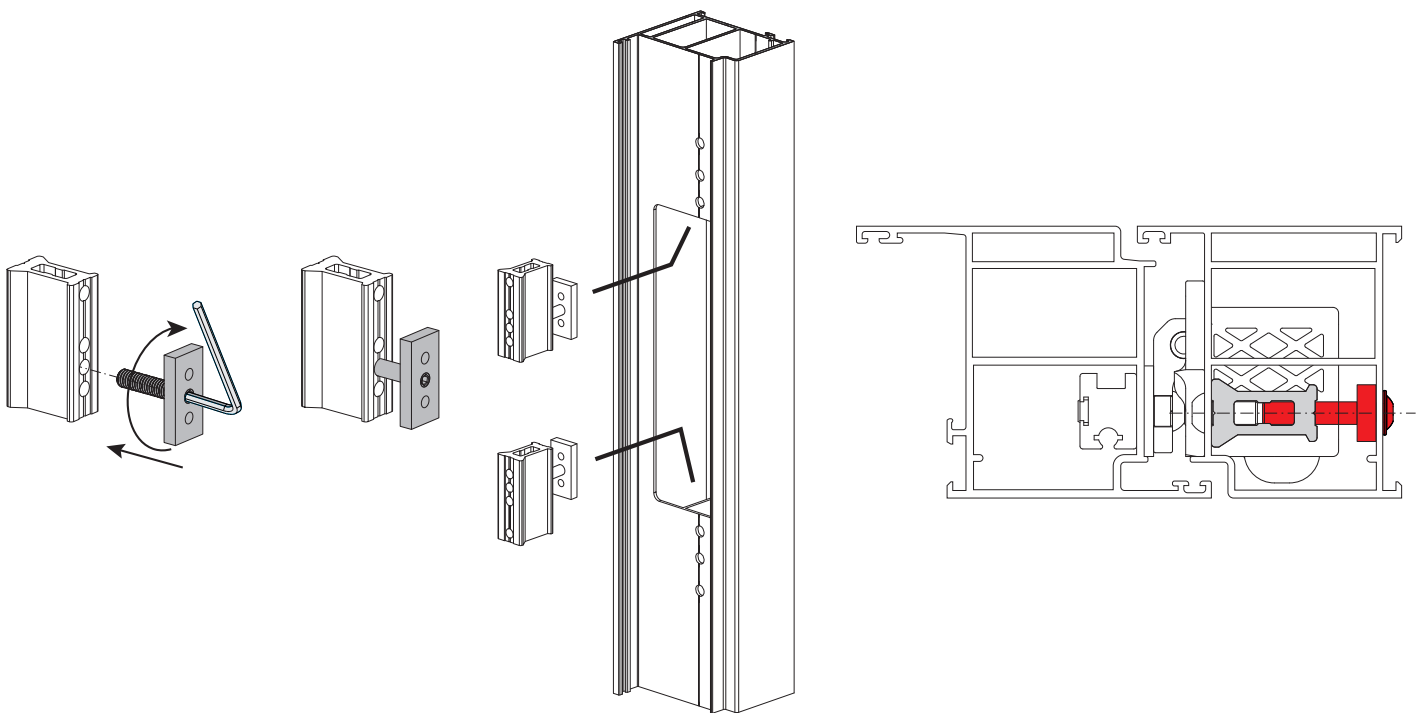

Item code	Description	Note	Base Raw	Anodised Elox	Painted	Trend/Gold Brass	Pieces per pack
00755	CHIC DOOR REINFORCEMENT KIT		X				5

CHIC DOOR INSTALLATION KIT



Functions

Positioning template for the frame hinge bodies correct alignment when fitting the sash.

It facilitates the sash joining to the frame keeping the pins of the different hinge bodies perfectly aligned with each other.

Online data sheet



Materials

POM

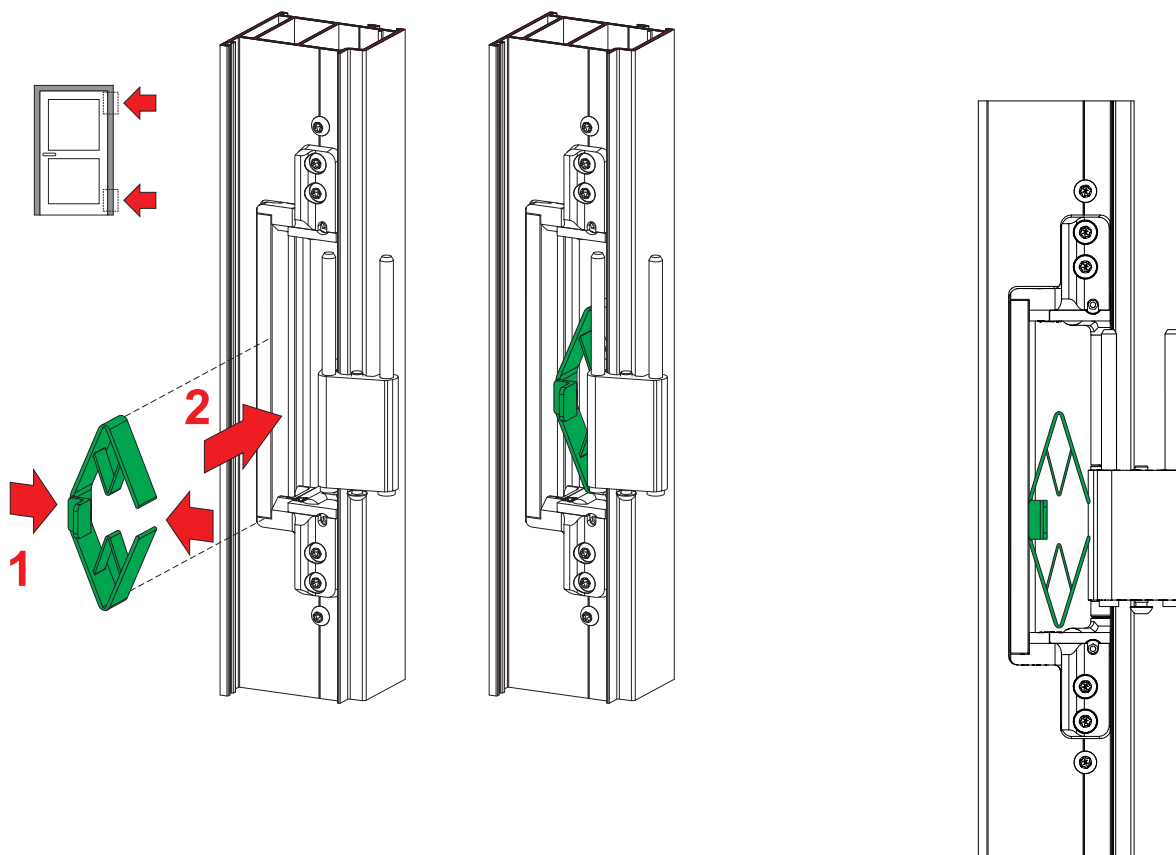

Item code	Description	Note	Base Raw	Anodised Elox	Painted	Trend/Gold Brass	Pieces per pack
00756	CHIC DOOR INSTALLATION KIT		X				20

CHIC DOOR EG HINGES



Functions

Reversible recessed door hinge, to be applied inside the profiles for complete product invisibility when the door is closed. With its innovative (patented) design, the product can be adjusted in two directions (laterally and in height) by a single operator.

Online data sheet



Technical Features

CHIC DOOR EG is a concealed hinge, suitable for aluminium doors, even of large dimensions and considerable weight.

An innovative design (patented) makes it possible to apply the product very quickly inside the profiles.

To apply the hinge, in fact, it is sufficient to simply make a machining on the frame and then insert the hinge into the sash channel.

The product is fixed to the frame by means of previously inserted slip-on plates in the frame channel.

CHIC DOOR EG adjustable in two directions:

- Side adjustment (+/- 2 mm.), using a hex wrench on the hinge adjusters.
- Height adjustment (- 2 /+ 4 mm.), using a hex wrench on the adjustment screw.

The hinge rotation angle is approx. 105° (also depending on the profile geometry).

If the sash can be opened > 90°, the use of a Friz limitation arm (art. 02030K) is recommended.

The sash adjustment operations can be carried out by a single operator directly on site.

CHIC DOOR EG is a CE marked product in compliance with standard EN1935 (200,000 cycles) - Class 12.

Materials

Hinge body in die-cast zamak
Hinge neck, frame fixing plates and height adjustment component in extruded aluminium
Hinge internal pin made of stainless steel
Screws and grub screws in stainless steel
Polyamide bushes

Capacities

120 kg with 2 hinges
135 kg with 3 hinges
150 kg with 4 hinges
For load capacities with door closer, see the relevant fitting instructions.

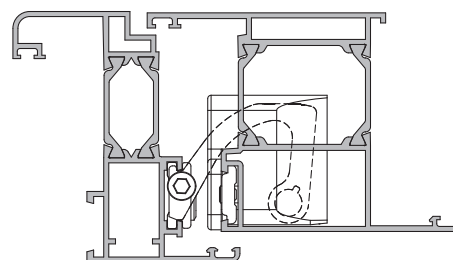

Height adjustment

Side adjustment

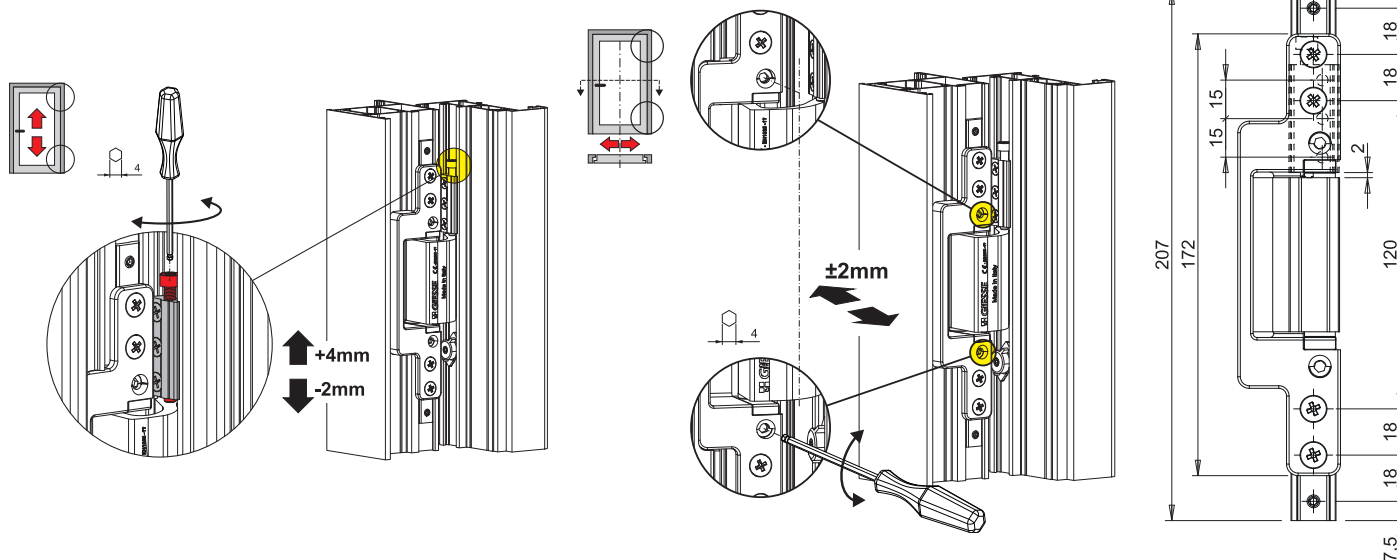

Item code	Description	PROFILE CROSS - SECTION	Version	Opening	Friz Arm	Height adjustment	Side adjustment	Base Raw	Anodised Elox	Painted	Trend/Gold Brass	Pieces per pack
00725	CHIC DOOR EG	C001	reversible	external	02030K	+4 / -2 mm	±2 mm		X			2

CONCEALED HINGES FOR DOOR

CHIC DOOR RG HINGES



Functions

Reversible recessed door hinge, to be applied inside the profiles for complete product invisibility when the door is closed.

With its innovative (patented) design, the product can be adjusted in two directions (laterally and in height) by a single operator.

Online data sheet



Technical Features

CHIC DOOR RG is a concealed hinge, suitable for aluminium doors, even of large dimensions and considerable weight.

An innovative design (patented) makes it possible to apply the product very quickly inside the profiles.

To apply the hinge, in fact, it is sufficient to simply make a machining on the frame and then insert the hinge into the sash channel.

The product is fixed to the frame by means of previously inserted slip-on plates in the frame channel.

CHIC DOOR RG adjustable in two directions:

- Side adjustment (+/- 2 mm.), using a hex wrench on the hinge adjusters.
- Height adjustment (- 2 / + 4 mm.), using a hex wrench on the adjustment screw.

The hinge rotation angle is approx. 105° (also depending on the profile geometry).

If the sash can be opened > 90°, the use of a Friz limitation arm (art. 02034K) is recommended.

The sash adjustment operations can be carried out by a single operator directly on site.

CHIC DOOR RG is a CE marked product in compliance with standard EN1935 (200,000 cycles) - Class 12.

Materials

Hinge body in die-cast zamak

Hinge neck, frame fixing plates and height adjustment component in extruded aluminium

Hinge internal pin made of stainless steel

Screws and grub screws in stainless steel

Polyamide bushes

Capacities

120 kg with 2 hinges

135 kg with 3 hinges

150 kg with 4 hinges

For load capacities with door closer, see the relevant fitting instructions.

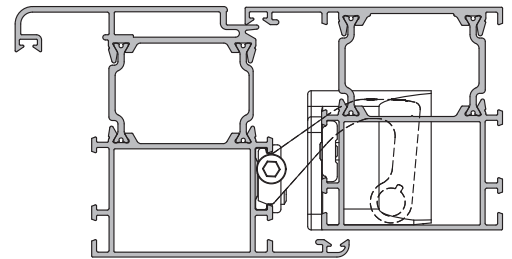

Height adjustment

Side adjustment

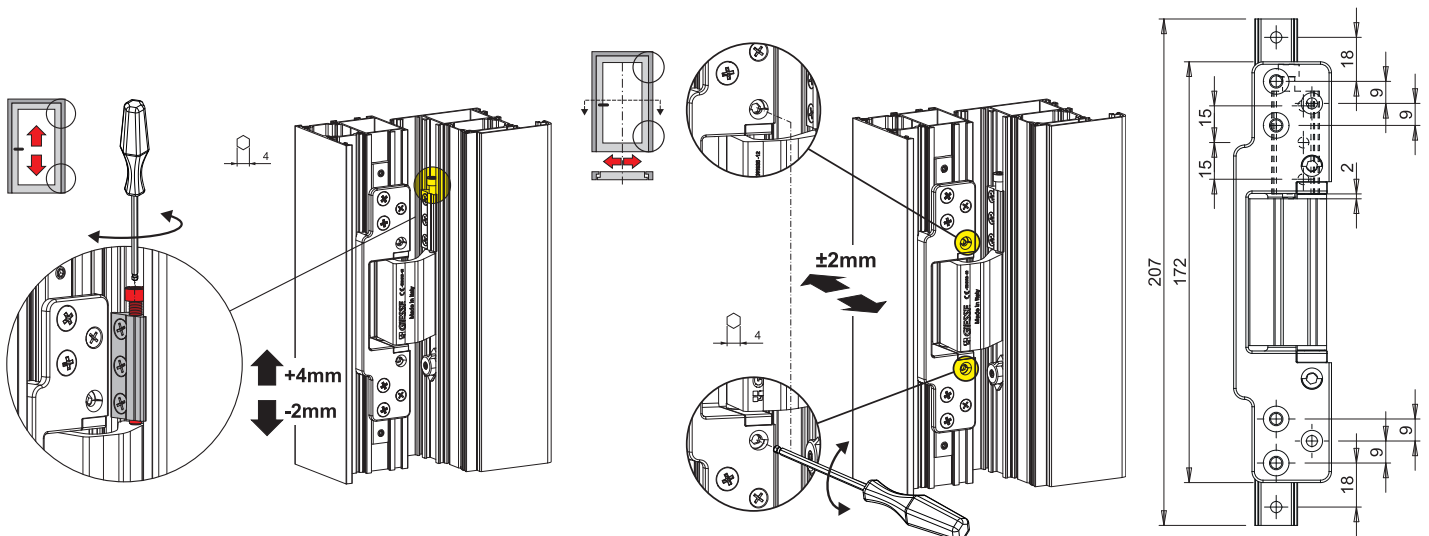

Item code	Description	PROFILE CROSS - SECTION	Version	Opening	Friz Arm	Height adjustment	Side adjustment	Base Raw	Anodised Elox	Painted	Trend/Gold Brass	Pieces per pack
00726	CHIC DOOR RG	C007	reversible	external	02034K	+4 / -2 mm	±2 mm		X			2

TECH PIVOT HINGES

**Functions**

Pivot hinge for horizontally and vertically sashes turning through 180°.

Online data sheet

**Technical Features**

Pivoted sash with friction-controlled opening up to 30°; gripping force selectable by turning a screw associated with both pivot hinges.

The sash opens to 30°; to open further for cleaning, press the release button located on one of the two hinges.

When the lever is released, the mechanism opens to 180° and will lock the sash automatically in this position to avoid unauthorized closures.

To close the sash, operate the release button again.

Each pair of Tech pivot hinges requires a set of fixing plates specific to the selected profile; these must be ordered separately.

Each set of plates comprises 2 sash plates and 2 frame plates.

The geometry of the sash-mounted plate is designed to allow the passage of closure hardware fitted to the perimeter.

Materials

Male and female hinge bodies, diecast zamak painted in RAL colours

Internal mechanisms made of diecast zamak

Release button, black polyamide

Extruded aluminium plates

Stainless steel screws

Capacities

Using Tech pivot hinges in combination with Giesse original plates, pivot sashes can be specified with the following maximum dimensions and weights:

Horizontal pivot-hinged sash

Maximum weight of sash (aluminium + glass): 120 Kg

Maximum sash dimensions: height 2200 mm - width 1600 mm

Vertical pivot-hinged sash

Maximum weight of sash (aluminium + glass): 100 Kg

Maximum sash dimensions: height 2200 mm - width 1600 mm

Horizontal pivot-hinged sash

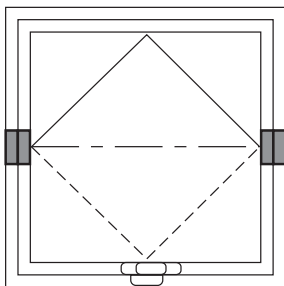

Vertical pivot-hinged sash

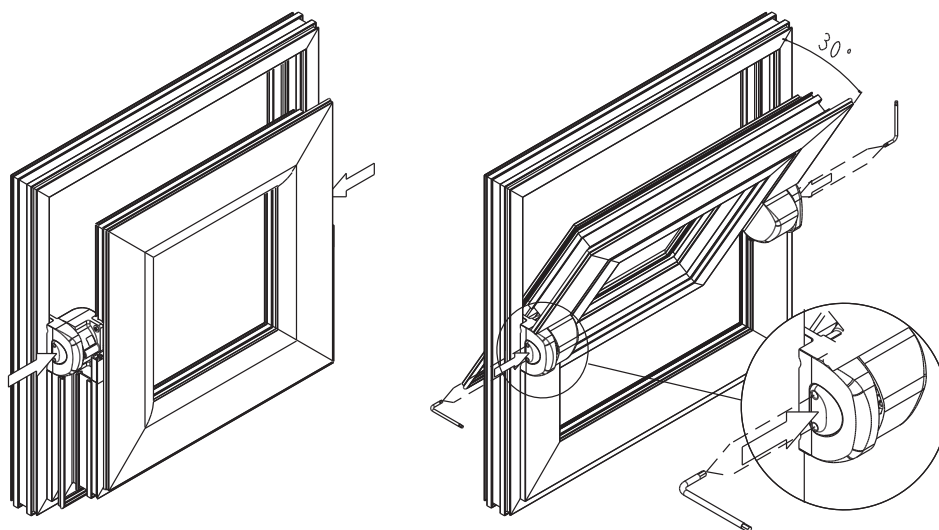
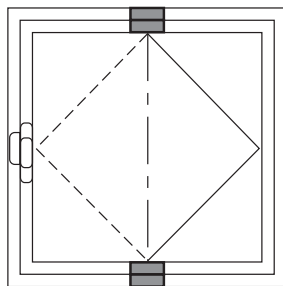

PIVOT HINGES

Fixing plates (specific to series)

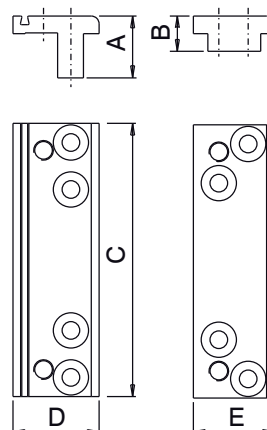
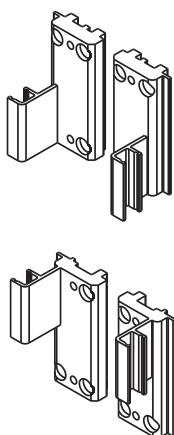

Item code	Description	PROFILE CROSS-SECTION	With lock	A (mm)	B (mm)	C (mm)	D (mm)	E (mm)	Base Raw	Anodised Elox	Painted	Trend/Gold Brass	Pieces per pack
01420	SET OF MOUNTING PLATES FOR TECH PIVOT HINGE	P001	-	15,8	9	69,8	22	20,7	X				4
01421	SET OF MOUNTING PLATES FOR TECH PIVOT HINGE	P002	-	10	15,8	69,8	20,7	20,9	X				4
01424	SET OF MOUNTING PLATES FOR TECH PIVOT HINGE	P005	-	11,3	17,5	69,8	21	22,5	X				4
01427	SET OF MOUNTING PLATES FOR TECH PIVOT HINGE	P007	-	13	19	69,8	20,5	24	X				4
01428	SET OF MOUNTING PLATES FOR TECH PIVOT HINGE	P008	-	10,75	17,5	69,8	21,5	22,5	X				4
01429	SET OF MOUNTING PLATES FOR TECH PIVOT HINGE	P001-P009	-	11,3	17,5	69,8	21	22,5	X				4
01439	TECH PIVOT HINGE WITHOUT PLATES	P001-P002-P003-P004-P005-P006-P007-P008-P009-P010	NO	-	-	-	-	-	X		X		4
01459	TECH PIVOT HINGE WITHOUT PLATES	P001-P002-P003-P005-P006-P007-P008-P009-P010	YES	-	-	-	-	-	X		X		4
01464	TECH PIVOT HINGE WITHOUT PLATES	-	YES	-	-	-	-	-	X	X	X		8

FRIBLOK PIVOT HINGES

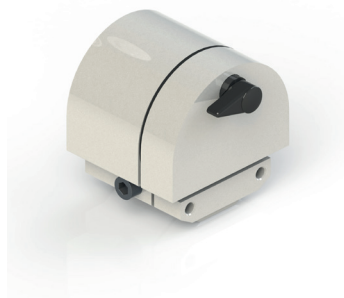
**Functions**

Pivot hinge for horizontally and vertically sashes turning through 180°, fashioned entirely from extruded aluminium billet using precision machining processes.

Online data sheet

**Technical Features**

Solidly reliable by virtue of the component structures and the inclusion of a device by which the window can be held at 30° and locked at 180°.

The 30° stop can be rendered inactive by fitting the polyamide insert in the relative slot.

A special screw allows external adjustment of the friction force applied: the action is particularly durable and effective as the metal walls are interfaced with one another by way of a polyamide thrust washer containing a high percentage of glass fibre.

Can also be supplied, to order, without the locking mechanism.

Applications and Load capacities of FRIBLOCK hinge pivots**Horizontal pivot-hinged sash**

Weight of sash distributed between the two pivot hinges

Using the fixing screws provided, the overall weight of the pivoted sash (glazing included) can be 70/80 kg.

Vertical pivot-hinged sash

Weight of sash supported entirely by the bottom pivot hinge

The bottom pivot hinge must be fitted with a polyamide thrust plug (code H5065010).

With normal fixing, the overall weight of the pivoting window (glazing included) can be 50/60 kg.

Materials

Extruded aluminium hinge body and fixing plates

Zamak clamp adjustment ring

Polyamide thrust washer

Screws and hinge pin of zinc-nickel plated steel.

Horizontal pivot-hinged sash

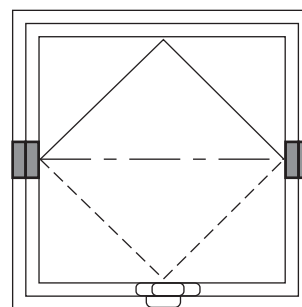

Vertical pivot-hinged sash

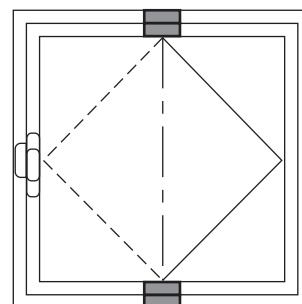

Pivot hinge with plates

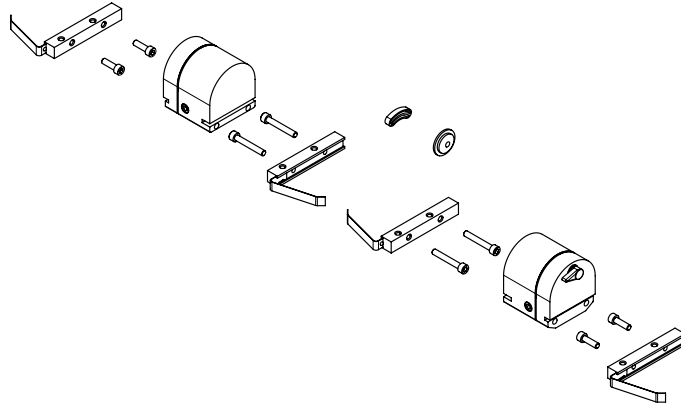

Pivot hinge without plates

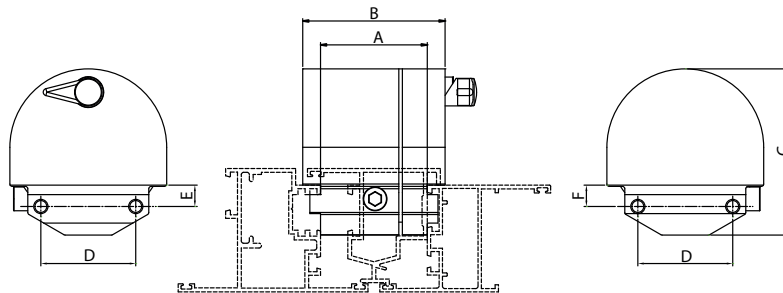
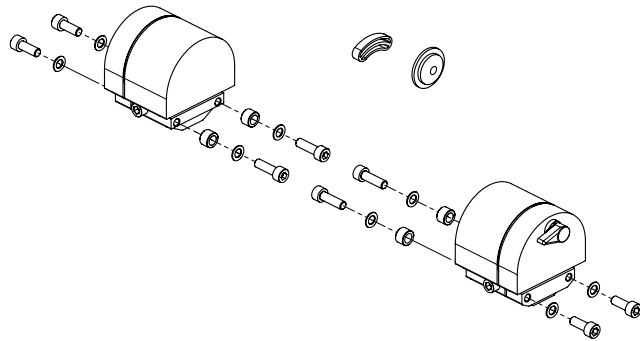

Item code	Description	PROFILE CROSS - SECTION	With plates	With screws	A (mm)	B (mm)	C (mm)	D (mm)	E (mm)	F (mm)	Base Raw	Anodised Elox	Painted	Trend/Gold Brass	Pieces per pack
01441	FRIBLOK PIVOT HINGE	P001	-	X	45	60	70	40	9	9	X	X	X		4
01443	FRIBLOK PIVOT HINGE	P002	-	X	47	60	70	40	10,5	10,5	X	X	X		4
01449	FRIBLOK PIVOT HINGE	see Where Used	-	X	47	68	70	26	19,5	19,5	X	X	X		4



**MECHANISMS
AND FASTENERS**

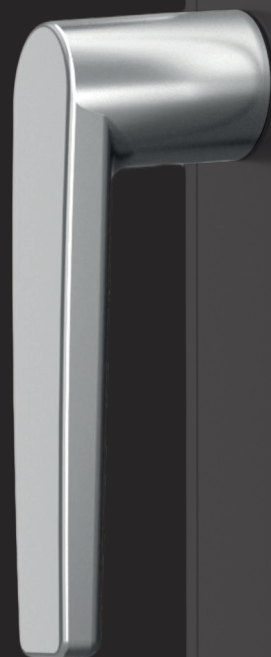

SUPRA 7 - MECHANISMS



Functions

Innovative reversible mechanism system without washer, which can be used for moving window sashes with different types of opening, having mechanisms compatible with 7 mm square pins.

Online data sheet



Technical Features

The Supra 7 window handles can be combined with the Giesse sash, Tilt-and-turn, Side Hung, Top Hung and Sliding movements and mechanisms which have a rotor with a 7 mm square slot.

The product, due to the exclusive Asia, Kora and Prima designs, can be combined with all the other Giesse products in the same line intended for other types of sashes (door, handles for lift-and-slide etc.).

The mechanism / movement must be firmly and independently fixed to the sash profile and receive the motion from the 7 mm pin of the Supra 7 window handle.

The machining to be carried out on the sash profile is simple and fast and Giesse has created 2 drilling templates to facilitate the operations (art. 03546 and art. 03547).

The product application takes place in 2 steps: first of all the base is fixed, with the integrated 7 mm pin, to the sash profile by means of the 4 TORX screws and then, after having pressed the handle firmly on the base, the pre-assembled grub screw is completely screwed onto the handle.

The supply includes 2 snap disks to be chosen based on the geometry of the sash profile.

The 7 mm square pin protrudes from the window handle support plane of 45 mm.

On request the length of the pin can be changed.

Materials

Handle in die-cast aluminium

Internal components made of GS SILVER PLUS

zamak, zinc plated steel and white polyamide

Zinc plated steel fixing screws, with Eslock treatment

SUPRA 7 system

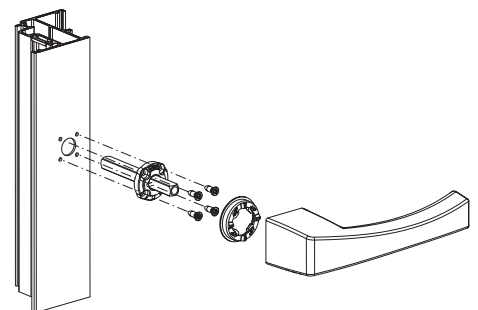
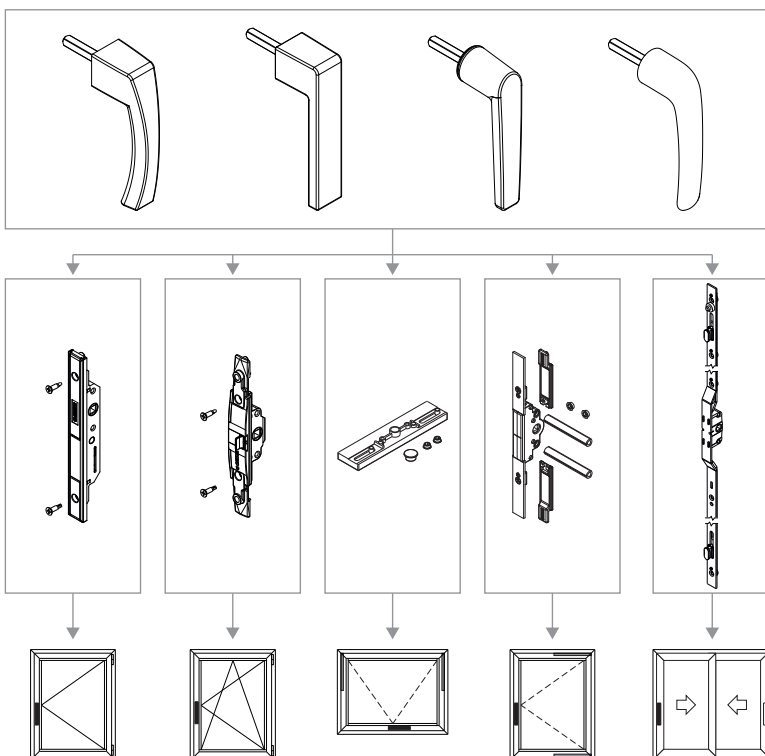

04153

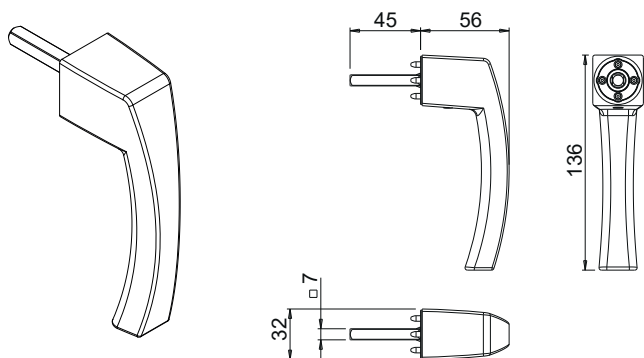

04154

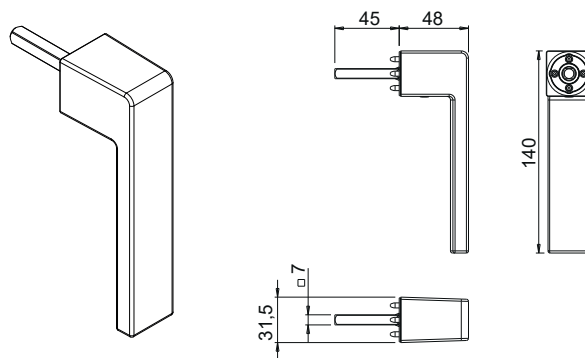

04155

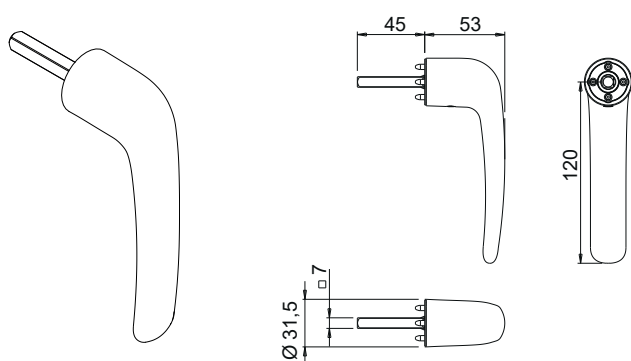

04156

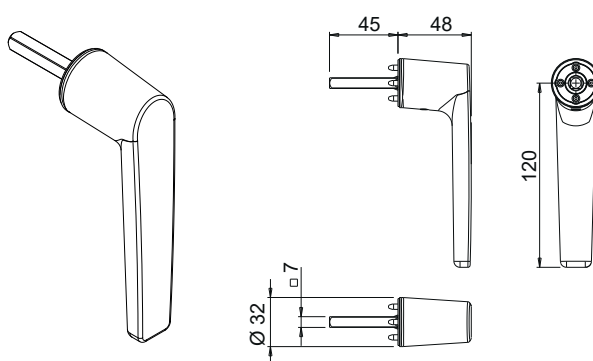

04164

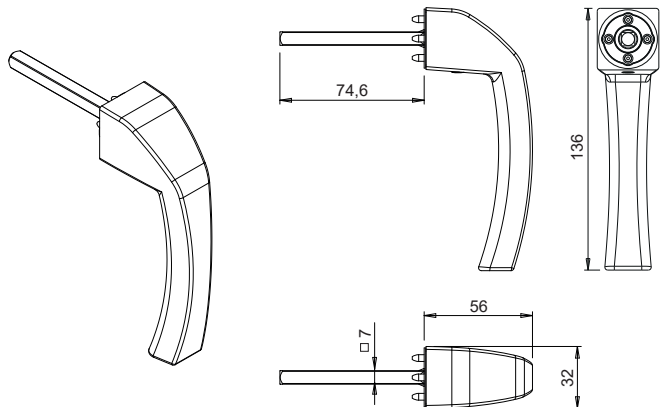

Fixing with 45° or 90° machining

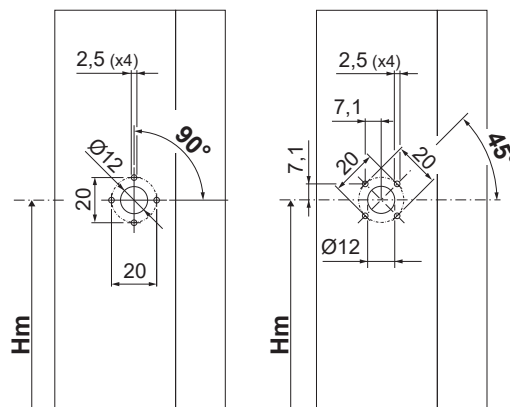

Item code	Description	Note	Base Raw	Anodised Elox	Painted	Trend/Gold Brass	Pieces per pack
04153	SUPRA 7 - ASIA MECHANISM		X		X	X	10
04154	SUPRA 7 - KORA MECHANISM		X		X	X	10
04155	SUPRA 7 - PRIMA MECHANISM		X		X	X	10
04156	SUPRA 7 - ARIA MECHANISM		X		X	X	10
04164	SUPRA 7 - ASIA APEX MECHANISM		X		X	X	10



SUPRA 7 - MECHANISM WITH OFFSET HANDLE

Functions

Innovative reversible mechanism system without washer, which can be used for moving window sashes with different types of opening, having mechanisms compatible with 7 mm square pins.

Version in which the square spindle and the mechanism are supplied separately, so the MECHANISM + the FIXING KIT are needed to create a SUPRA 7.

Online data sheet



Technical Features

The Supra 7 window handles can be combined with the Giesse sash, Tilt-and-turn, Side Hung, Top Hung and Sliding movements and mechanisms which have a rotor with a 7 mm square slot.

The mechanism / movement must be firmly and independently fixed to the sash profile and receive the motion from the 7 mm pin of the Supra 7 window handle.

The machining to be carried out on the sash profile is simple and fast and Giesse has created 2 drilling templates to facilitate the operations (art. 03546 and art. 03547).

The product application takes place in 2 steps: first of all the base is fixed, with the integrated 7 mm pin, to the sash profile by means of the 4 TORX screws and then, after having pressed the handle firmly on the base, the pre-assembled grub screw is completed screwed onto the handle.

The supply includes 2 snap disks to be chosen based on the geometry of the sash profile.

The 7 mm square pin protrudes from the window handle support plane of 45 mm.

On request the length of the pin can be changed.

Materials

Handle in die-cast aluminium

Internal components made of GS SILVER PLUS zamak, zinc plated steel and white polyamide

Zinc plated steel fixing screws, with Eslock treatment

Fixing with 45° or 90° machining

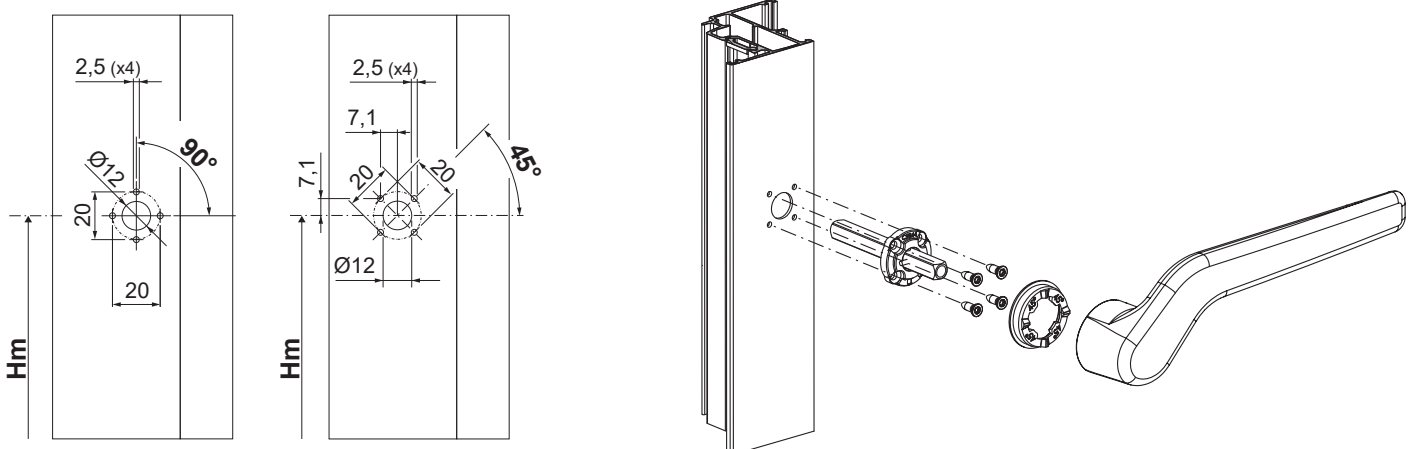

052621

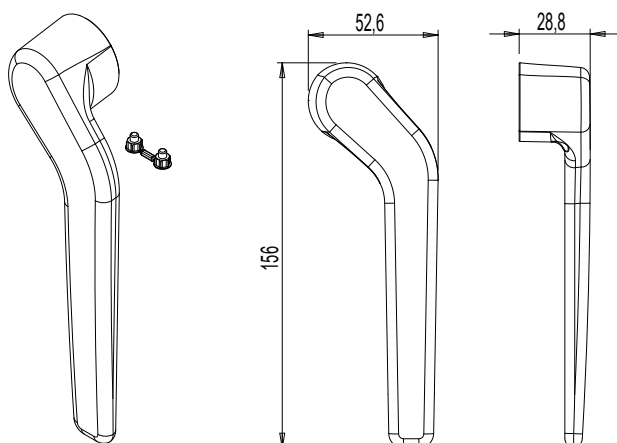

052622

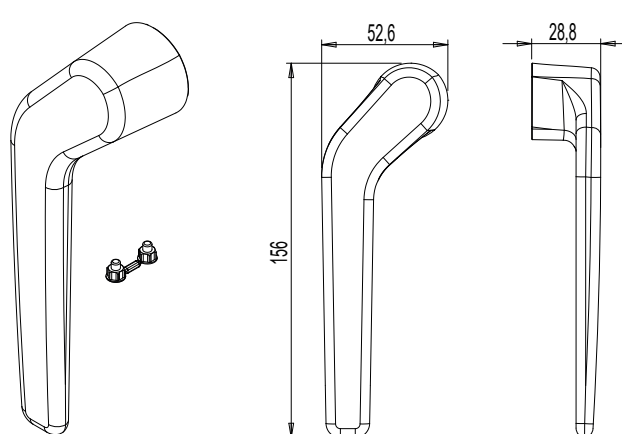

05560

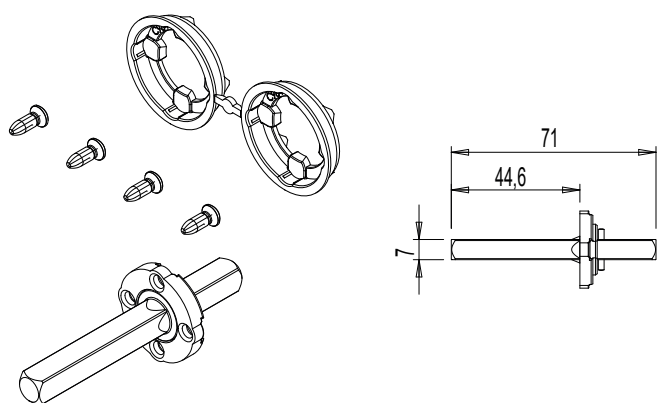

05261

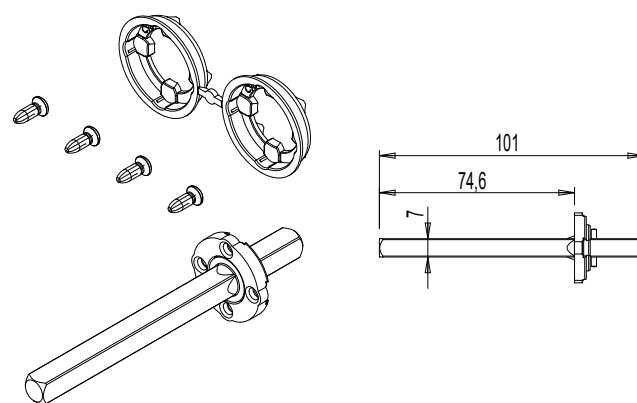

Item code	Description	Notes	Square spindle length [mm]	Base Raw	Anodised Elox	Painted	Trend/Gold Brass	Pieces per pack
052621	SUPRA 7-OFFSET MECHANISM	RX		X		X		10
052622	SUPRA 7-OFFSET MECHANISM	LX		X		X		10
05560	SUPRA 7 - FIXING KIT		71	X				10
05261	SUPRA 7 - FIXING KIT		101	X				10



SUPRA 7 - DOUBLE WINDOW HANDLES

Functions

Innovative double mechanism system without washer which can be used for moving window sashes with different types of opening, having mechanisms compatible with 7 mm square pins and which can be combined with all Giesse products having the same design.

Online data sheet



Technical Features

The Supra 7 double window handles can be combined with the Giesse sliding casement and side-hung sash movements and mechanisms which have a rotor compatible with 7 mm square pins.

The product, due to its exclusive design, can be combined with all the other Giesse products having the same design intended for other types of sashes (door, handles for lift-and-slide etc.).

Products applicable on sash with profiles wide from 26 to 85 mm.

Materials

Handle in die-cast aluminium

Internal components made of GS SILVER PLUS zamak, zinc plated steel and white polyamide

Zinc plated steel fixing screws, with Eslock treatment

Fixing with 45° or 90° machining

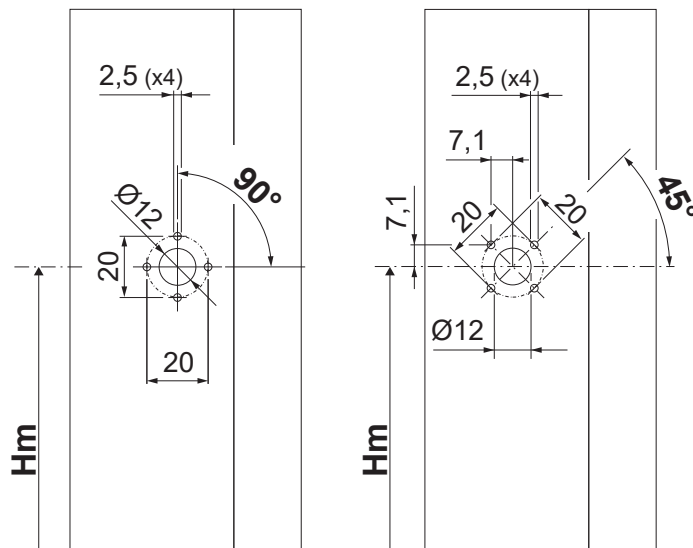

04395

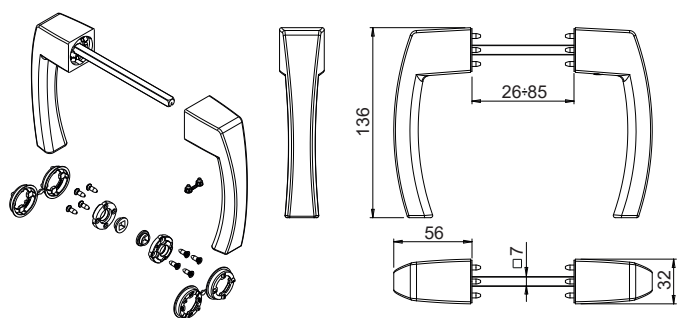

04396

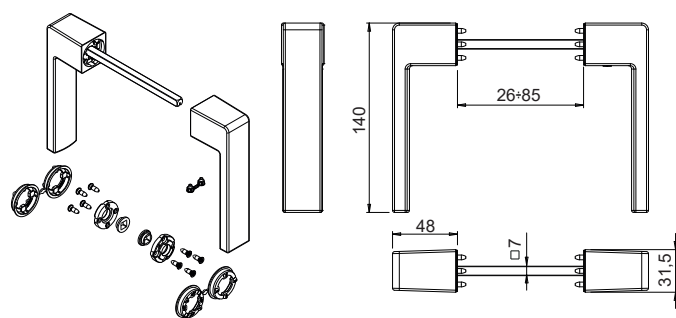

04397

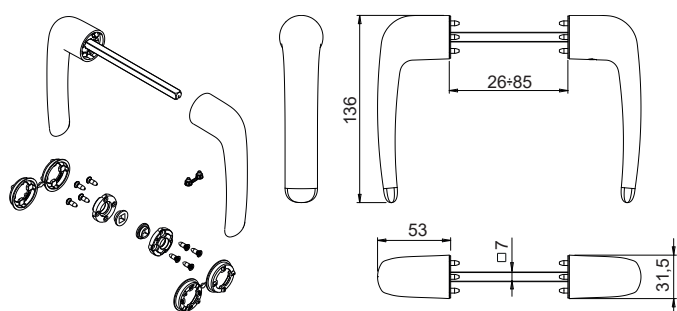

04398

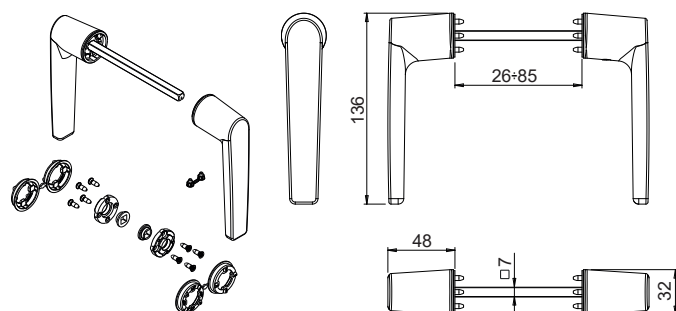

04399

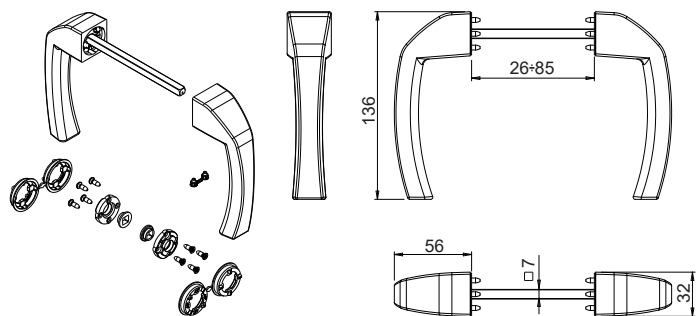

Item code	Description	Type of pin (mm)	Pin length (mm)	Sash width (mm)	Pull handle 0°	Pull handle 90°	Base Raw	Anodised Elox	Painted	Trend/Gold Brass	Pieces per pack
04395	SUPRA 7 - ASIA DOUBLE WINDOW HANDLE	7	112	26 ÷ 85	Closed	Open	X		X	X	5
04396	SUPRA 7 - KORA DOUBLE WINDOW HANDLE	7	112	26 ÷ 85	Closed	Open	X		X	X	5
04397	SUPRA 7 - PRIMA DOUBLE WINDOW HANDLE	7	112	26 ÷ 85	Closed	Open	X		X	X	5
04398	SUPRA 7 - ARIA DOUBLE WINDOW HANDLE	7	112	26 ÷ 85	Closed	Open	X		X	X	5
04399	SUPRA 7 - ASIA APEX DOUBLE WINDOW HANDLE	7	112	26 ÷ 85	Closed	Open	X		X	X	5

SUPRA 7 - DRILLING TEMPLATE



Functions

Drilling template for carrying out machining on the SUPRA 7 window handle.

Online data sheet



Technical Features

The drilling template art. 03546 can be used for Euro groove (Euro groove central gasket) or R40 inward opening systems, by applying the two supplied pins in holes "A" or "B".

The drilling template art. 03547 is a universal template that can be applied to different types of systems (Sliding, Side Hung, Top Hung, Inward Swing, etc.) as it uses a 7 mm square pin, included in the supply, as reference point, to be inserted in the slot of the mechanism rotor.

To improve machining precision, we recommend holding it in place using a clamp.

Materials

Art. 03546: Aluminium template body, Steel bushings

Art. 03547: Steel template body and square pin

Possibility of 45° or 90° machining

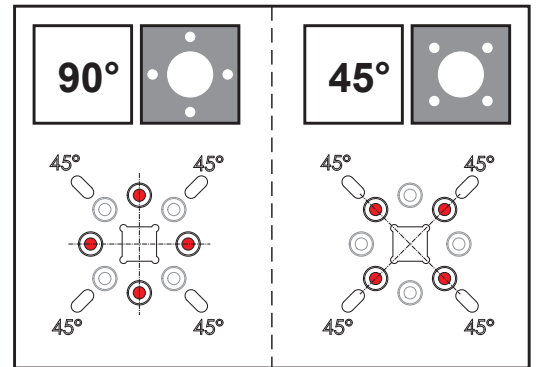

03546

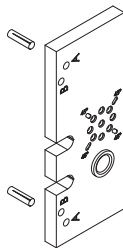

03547

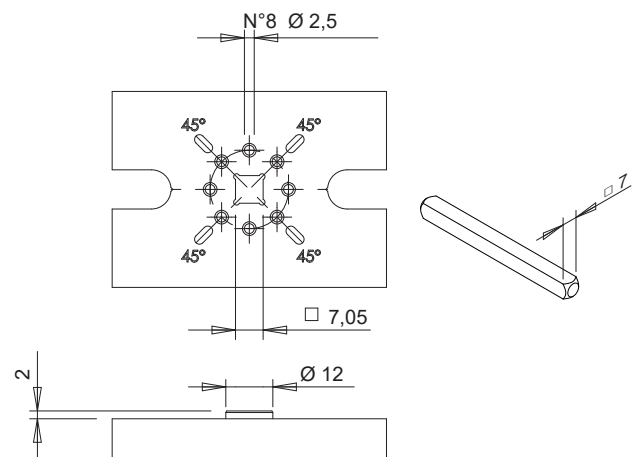
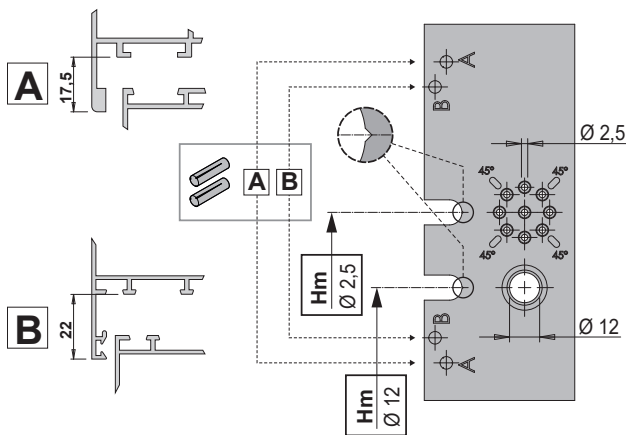
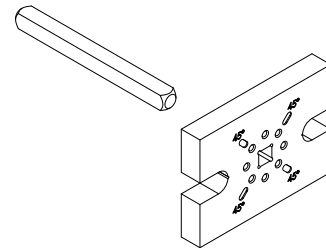

Item code	Description	Note	Base Raw	Anodised Elox	Painted	Trend/Gold Brass	Pieces per pack
03546	SUPRA 7 DRILLING TEMPLATE	C.E.-R40	X				1
03547	SUPRA 7 UNIVERSAL TEMPLATE		X				1

NP SUPRA

Functions

Innovative system of window handles and hardware for operating casements with Inward Opening SASH and TILT-AND-TURN. Thanks to GIESSE NP® Technology you can make casements with modern styling and minimal, fast machining on the profile.

Technical Features

The system works by combining hardware and a window handle that are joined together by a 5 mm hexagon. Assembling the window handle requires machining the sash profile, which can also be done by using a dedicated punch. The hardware is available in a two-way version (SASH) and one-way version (TILT-AND-TURN). The hardware needs no machining on the profile and is secured by means of two self-tapping screws supplied.



NP SUPRA System

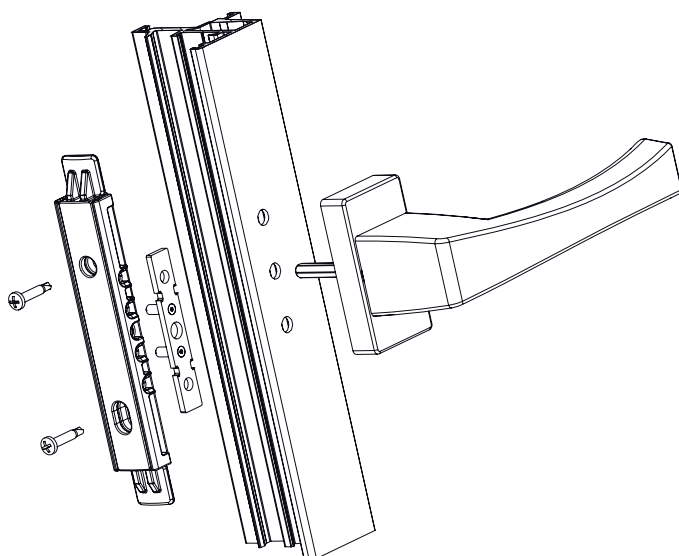
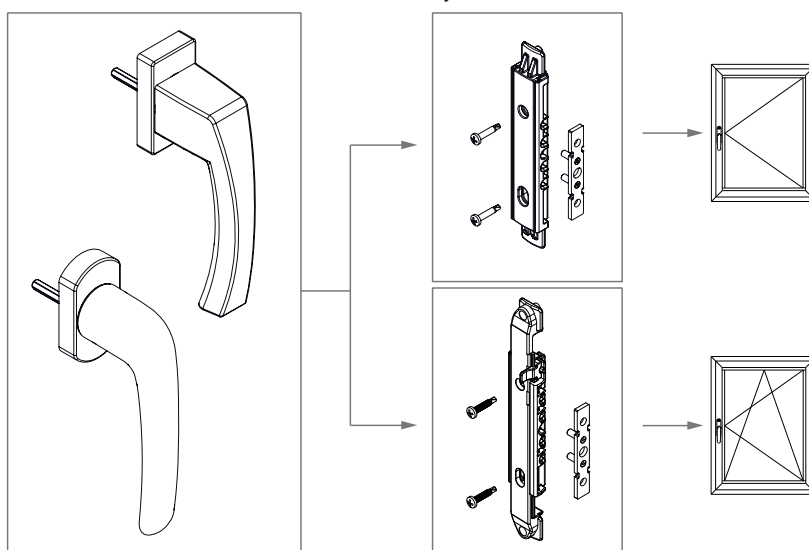

Punch art. 5810120000

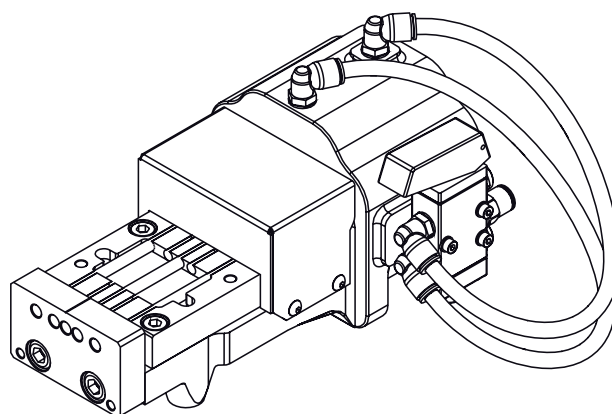

NP SUPRA - ASIA WINDOW HANDLE



Functions

Reversible window handle for operating Sash and Tilt-and-Turn NP SUPRA window handles.

Online data sheet



Technical Features

Same window handle for both Sash and Tilt-and-Turn.
Used in combination with NP SUPRA Hardware.
It is locked to the profile by screwing the 2 special screws, pre-assembled on the window handle body, into the fixing plate provided in the mechanism.
There is no need for any milling on the sash tubular profile, it only requires straightforward machining on the profile wall (3 holes $\text{\O}6.2$ mm), so there is a specific punch.

Materials

Handle in die-cast aluminium.
Internal components made of GS SILVER PLUS zamak, zinc plated steel and black polyamide.
Zinc plated steel fixing screws.
Die-cast zamak cover.

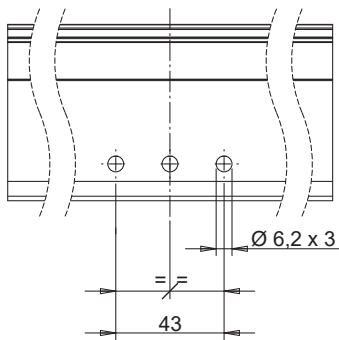
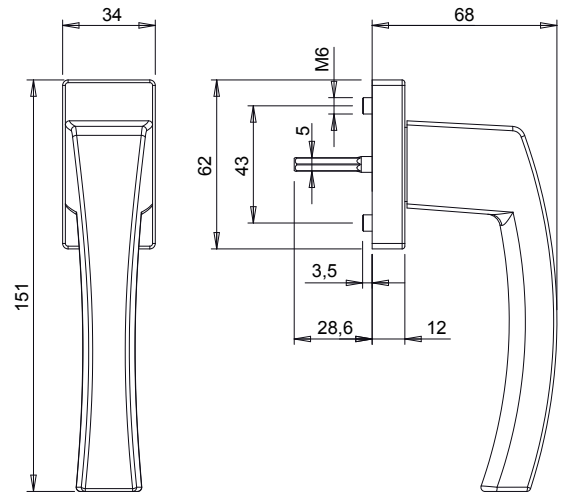

Machining

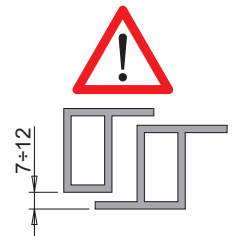
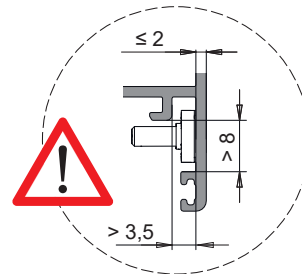
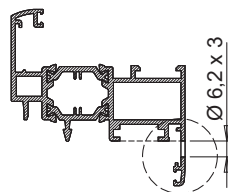

Sash

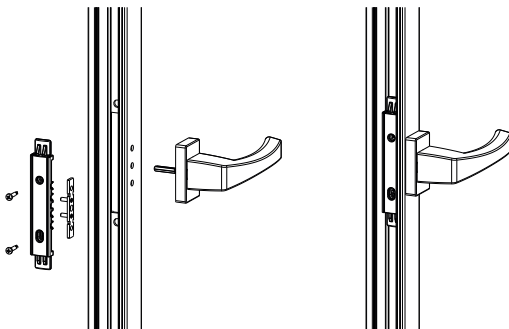

Tilt-and-turn window

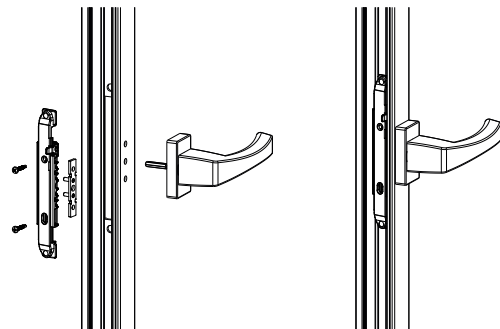

Item code	Description	PROFILE CROSS - SECTION	Type	Base Raw	Anodised Elox	Painted	Trend/Gold Brass	Pieces per pack
03963	NP - ASIA WINDOW HANDLE	C001-C002-C003-C005-C006-C013-C014-C015-C017	Sash - Tilt-and-Turn	X		X		10

NP SUPRA - PRIMA WINDOW HANDLE



Functions

Reversible window handle for operating Sash and Tilt-and-Turn NP SUPRA window handles.

Online data sheet



Technical Features

Same window handle for both Sash and Tilt-and-Turn.
Used in combination with NP SUPRA Hardware.
It is locked to the profile by screwing the 2 special screws, pre-assembled on the window handle body, into the fixing plate provided in the mechanism.
There is no need for any milling on the sash tubular profile, it only requires straightforward machining on the profile wall (3 holes Ø6.2 mm), so there is a specific punch.

Materials

Handle in die-cast aluminium.
Internal components made of GS SILVER PLUS zamak, zinc plated steel and black polyamide.
Zinc plated steel fixing screws.
Die-cast zamak cover.

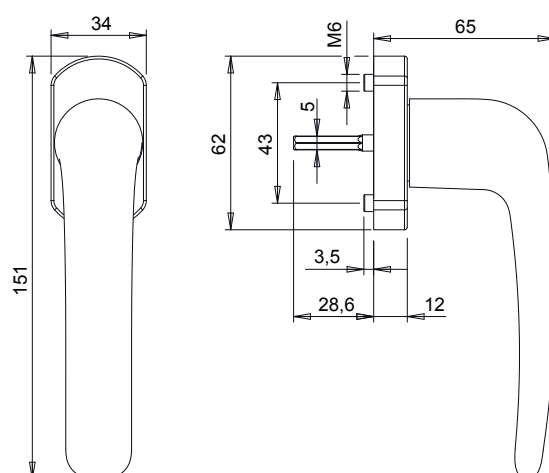

Machining

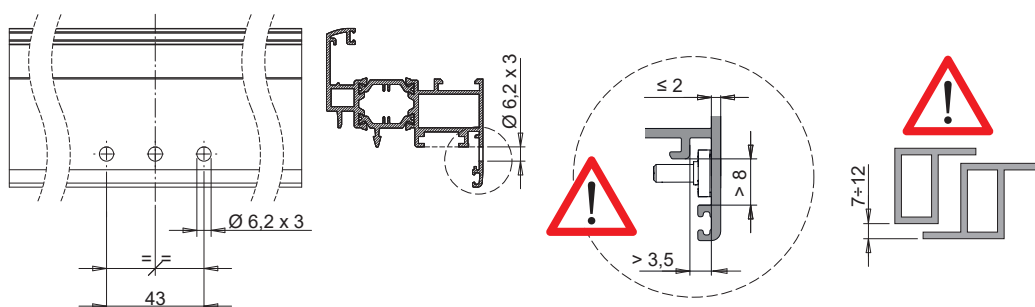

Sash

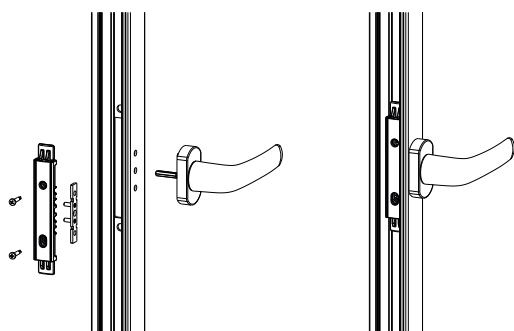

Tilt-and-turn window

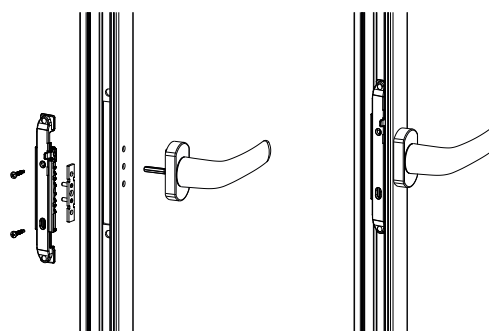

Item code	Description	PROFILE CROSS - SECTION	Type	Base Raw	Anodised Elox	Painted	Trend/Gold Brass	Pieces per pack
03962	NP - PRIMA WINDOW HANDLE	C001-C002-C003-C005-C006-C013-C014-C015-C017	Sash - Tilt-and-Turn	X		X		10

NP SUPRA - TILT-AND-TURN HARDWARE

Functions

One-way window handle, can be operated with the NP SUPRA window handle, for operating Tilt-and-Turn fastening window handles.

Online data sheet



Technical Features

Used in combination with the NP SUPRA window handle (5 mm hexagon). It is locked to the profile with the 2 self-tapping screws supplied. There is no need for any milling on the sash tubular profile, it only requires straightforward machining on the profile wall (3 holes $\text{\O}6.2$ mm). The mechanism is two-way and is equipped with an incorrect movement safety device, which prevents turning the window handle while the sash is open.

Materials

Body, Drive Rod and incorrect movement safety lug made of zamak with GS SILVER PLUS finish. Pinion and screws 3.9 x 19 made of zinc plated steel. Stainless steel fixing plate.

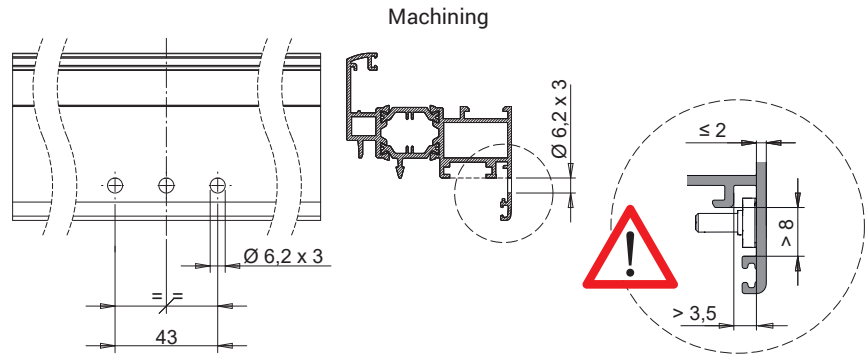
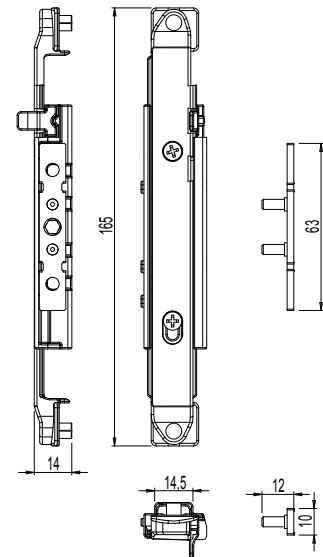

Asia window handle

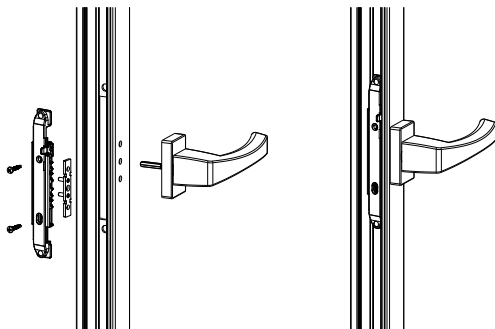

Prima window handle

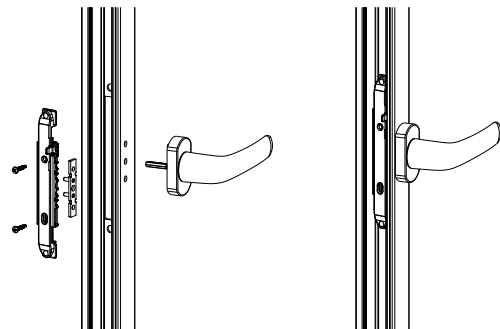

Item code	Description	PROFILE CROSS - SECTION	Type	Operation	Base Raw	Anodised Elox	Painted	Trend/Gold Brass	Pieces per pack
0395301	NP - TILT-AND-TURN HARDWARE	C001-C002-C003-C004-C005-C006-C013-C014-C015-C016-C017	Tilt-and-turn window	one-way	X				10

NP SUPRA - SASH HARDWARE



Functions

Two-way window handle, can be operated with the NP SUPRA window handle, for operating Sash fastening window handles.

Online data sheet



Technical Features

Used in combination with the NP SUPRA window handle (5 mm hexagon). It is locked to the profile with the 2 self-tapping screws supplied. There is no need for any milling on the sash tubular profile, it only requires straightforward machining on the profile wall (3 holes $\text{Ø}6.2$ mm). The mechanism is two-way.

Materials

Body, Drive Rod (top and bottom) made of zamak with GS SILVER PLUS finish. Pinion and screws 3.9 x 19 made of zinc plated steel. Stainless steel fixing plate.

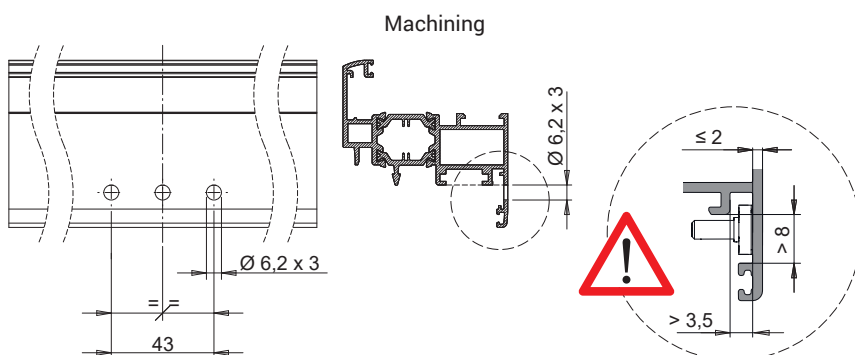
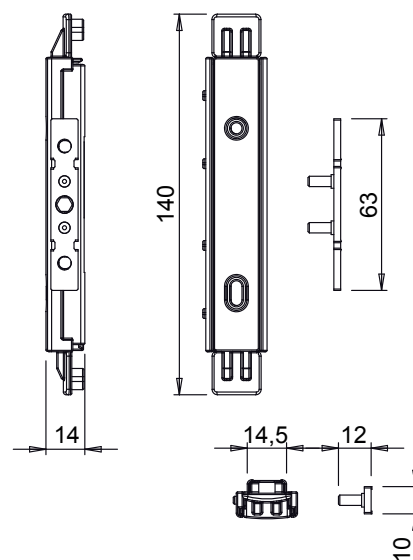

Asia window handle

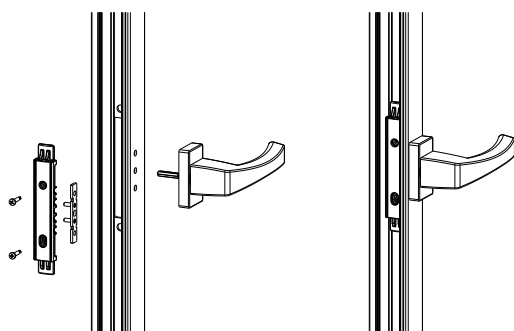

Prima window handle

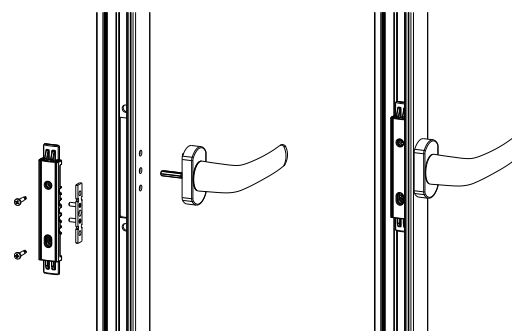

Item code	Description	PROFILE CROSS - SECTION	Type	Operation	Base Raw	Anodised Elox	Painted	Trend/Gold Brass	Pieces per pack
03954	NP - SASH MECHANISM	C001-C002-C003-C004-C005-C006-C013-C014-C015-C016-C017	Sash	two-way	X				10

NP SUPRA - DRILLING TEMPLATE



Functions

Drilling template for carrying out machining on the NP SUPRA window handle.

Online data sheet



Technical Features

The pin supplied makes it possible to set the template for profiles with tabs 17.5 mm (A) or 18.0 mm (B) in length.

To improve machining precision, we recommend holding it in place using a clamp.

Materials

Aluminium template
Steel bushes and pins

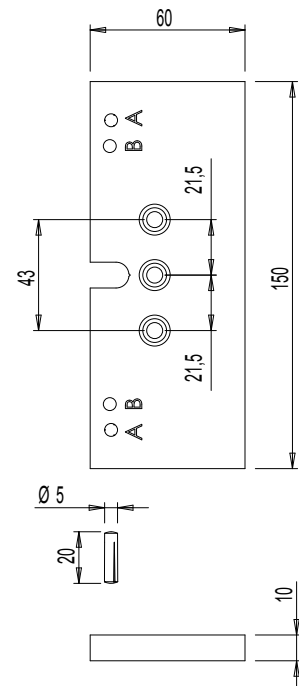
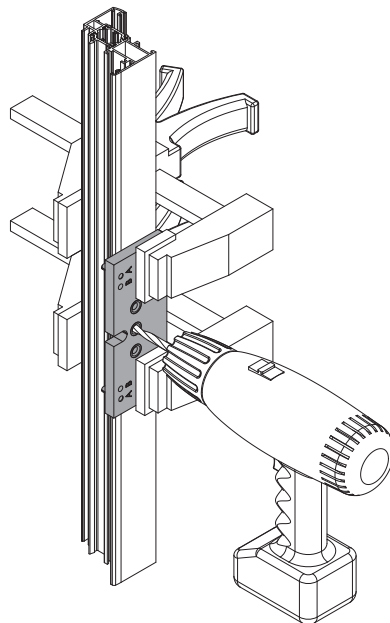
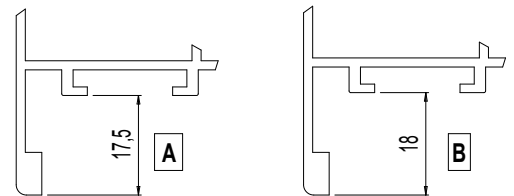

Item code	Description	Note	Base Raw	Anodised Elox	Painted	Trend/Gold Brass	Pieces per pack
03536	NP SUPRA - DRILLING TEMPLATE		X				1



KORA CREMONE

Functions

Reversible cremone handle for operating the GIESSE Sash, Tilt-and-Turn Window and Tilt-and-Turn Window with Microventilation mechanisms.

Online data sheet



Technical Features

The use of high quality die-cast materials and the GIESSE painting system guarantee excellent mechanical performance, together with colour uniformity and good abrasion resistance.

The Kora cremone has a fixing C/C distance of 104 mm and 92 mm, but can be easily adapted for fixing with a C/C distance of 84 and 98 mm.

Materials

Handle in die-cast aluminium
 Cremone case, gear racks in die-cast zamak
 Internal sheath and Hostaform plate
 Steel spring
 Stainless steel screws and fixing plate

Overall dimensions of cremone for sash

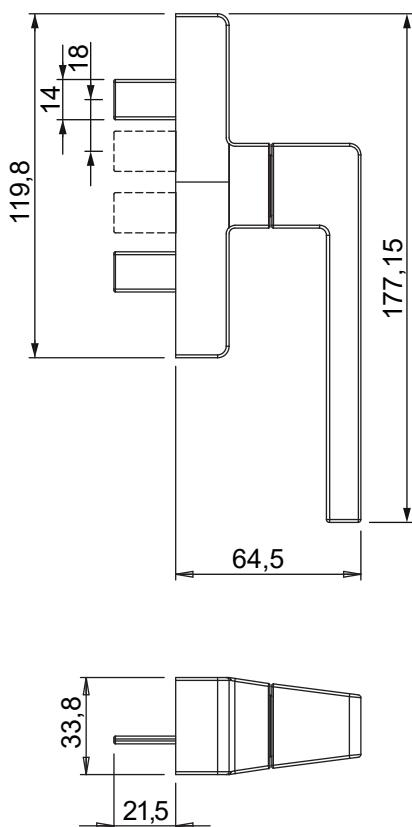

Overall dimensions of cremone for tilt-and-turn

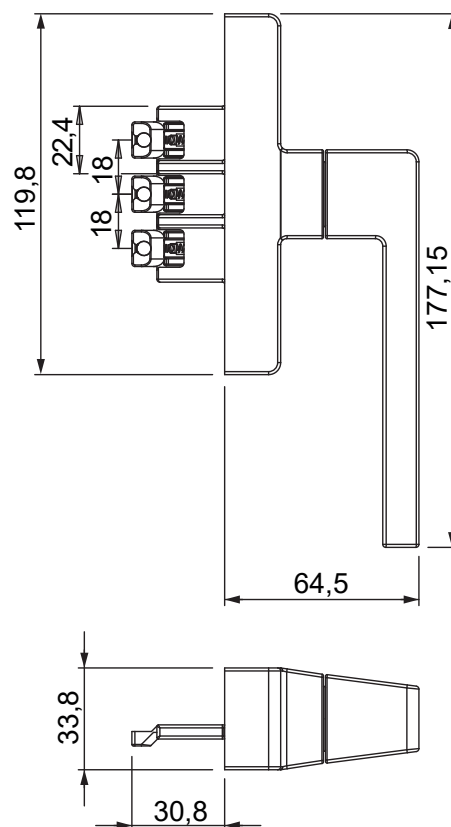

C/C distance machining 104 mm

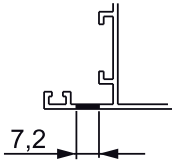
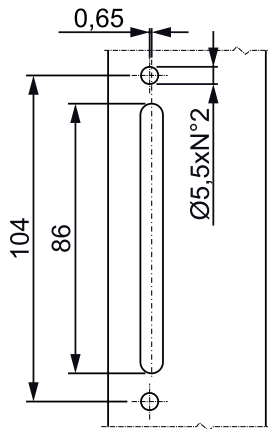

C/C distance machining 98 mm

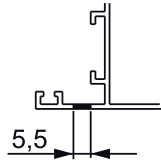
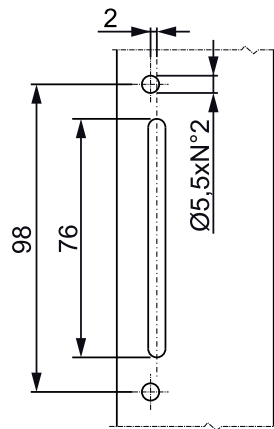

C/C distance machining 92 mm

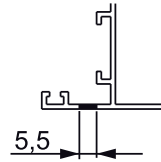
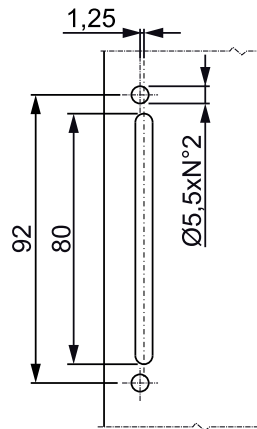

C/C distance machining 84.5 mm

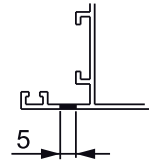
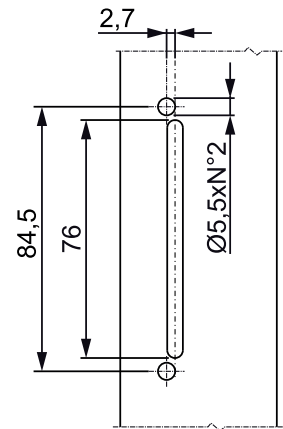

Item code	Description	PROFILE CROSS - SECTION	Type	C/C distances	Operation	Pull handle 0°	Pull handle 90°	Pull handle 135°	Pull handle 180°	Base Raw	Anodised Elox	Painted	Trend/Gold Brass	Pieces per pack
00957	KORA CREMONE	C001-C002-C003-C004-C005-C006-C007-C008-C009-C010-C012-C013-C014-C015-C016-C017-P001-P002-P004-P005-P006-P007-P008-P009-P010	Sash	104 - 98 - 92 - 84	two-way	closed	open	-	-	X		X	X	10
00959	KORA T/T MICRO-VENTILATION CREMONE	C001-C002-C003-C004-C005-C006-C007-C008-C009-C010-C012-C013-C014-C015-C016-C017	Tilt-and-turn window (microventilation)	104 - 98 - 92 - 84	one-way	closed	open	micro	bot-tom-hung windows	X		X	X	10

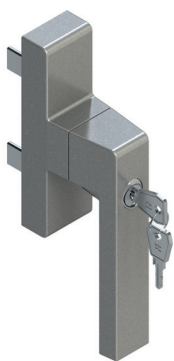

KORA KEY CREMONE

Functions

Reversible cremone, with key lockable handle, with rotation through 90°, 135° (micro-ventilation version) and 180° and opening/closing positioning notch.

Online data sheet



Technical Features

The use of high quality die-cast materials and the GIESSE painting system guarantee excellent mechanical performance, together with colour uniformity and good abrasion resistance.

The cylinders of the KORA KEY cremones have homogeneous coding, on request it is in any case possible to fulfill specific job orders with customized coding.

The cylinder of the KORA KEY Logica and Microventilation Logica cremones has the Giesse Key Capture system.

The cylinder, depending on the version, allows locking the handle of the cremone to 90°, 135° and 180°. When the handle is at 90° or 135° it is possible to remove the key and then leave the sash in the tilt-and-turn or micro-ventilation position, in safety.

When the pull handle is at 180°, and therefore the sash is in the fully open position, it is not possible to remove the key from the cylinder.

Materials

Handle in die-cast aluminium

Die-cast Zamak case, gears, racks and sliding parts

Nickel-plated brass cylinder

Hostaform plate

Spring, screws and fixing plate in stainless steel

Overall dimensions art. 00958

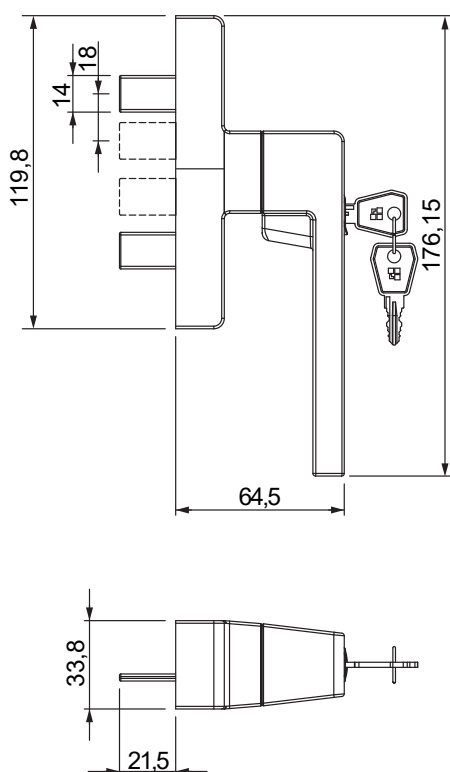

Overall dimensions art. 00960

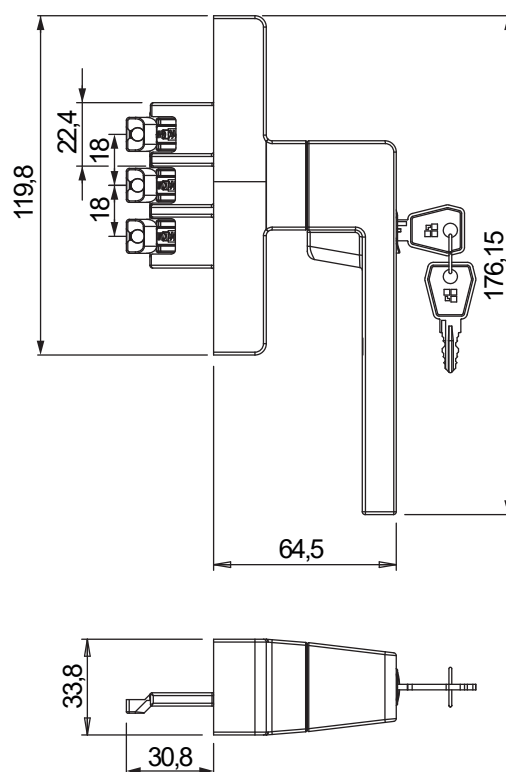

C/C distance machining 104 mm

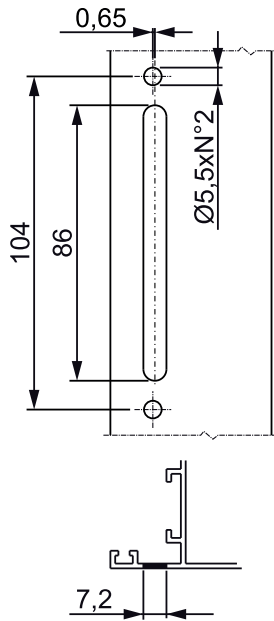

C/C distance machining 98 mm

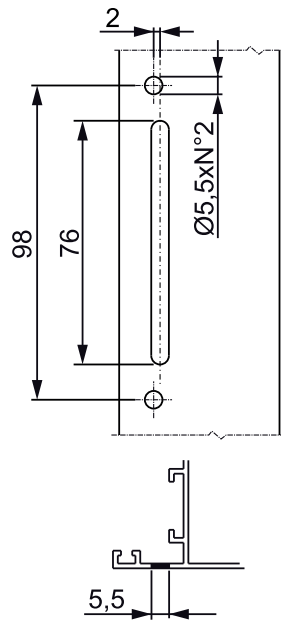

C/C distance machining 92 mm

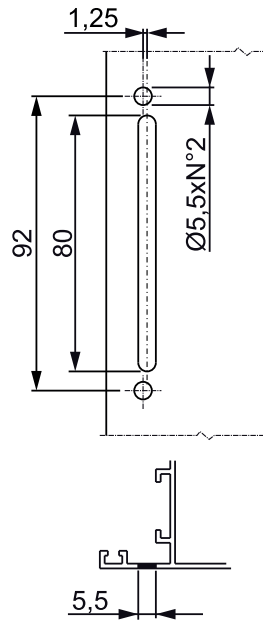

C/C distance machining 84.5 mm

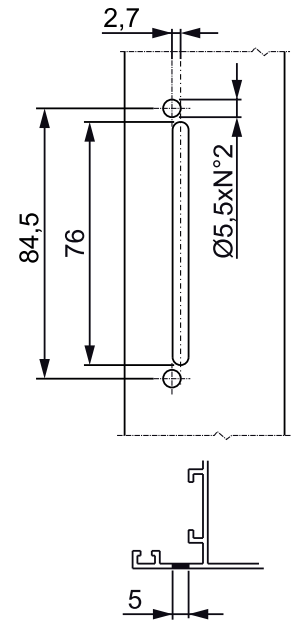

Item code	Description	PROFILE CROSS - SECTION	Type	Version	C/C distances	Performance	Operation	Pull handle 0°	Pull handle 90°	Pull handle 135°	Pull handle 180°	Base Raw	Anodised Elox	Painted	Trend/Gold Brass	Pieces per pack
00958	KORA KEY CREMONE	C001-C002-C003-C004-C005-C006-C007-C008-C009-C010-C012-C013-C014-C015-C016-C017-P001-P002-P004-P005-P006-P007-P008-P009-P010	Sash	-	104 - 98 - 92 - 84	> 100 N/m	two-way	closed	open	-	-	X		X	X	5
00960	SKG KORA KEY MICRO CREMONE	C001-C002-C003-C005-C006-C013-C014-C015-C016-C017	Tilt-and-turn window	Micro	104 - 98 - 92 - 84	> 100 N/m	one-way	closed	open	micro	bot-tom-hung windows	X		X	X	5
00961	KORA KEY T/T CREMONE LGC	C001-C002-C003-C004-C005-C006-C007-C008-C009-C010-C012-C013-C014-C015-C016-C017	Tilt-and-turn window	Logica	104 - 92	> 100 N/m	one-way	closed	bot-tom-hung windows	-	open	X		X	X	5
00962	KORA KEY T/T CREMONE LGC MICRO	C001-C002-C003-C004-C005-C006-C007-C012-C013-C014-C015-C016-C017	Tilt-and-turn window	Micro	104 - 92	> 100 N/m	one-way	closed	bot-tom-hung windows	micro	open	X		X	X	5

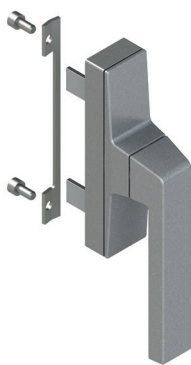

KORA 0-180 CREMONE

Functions

Reversible cremone for operating GIESSE mechanisms.

Online data sheet



Technical Features

Available either with two-way mechanism for sashes or in the APEX version. The Kora cremone is supplied right-handed and has a fixing C/C distance of 104 mm.

The Kora Apex Cremone can be fitted on shutter profiles or with outward opening, and does not need to use the internal connection kit.

The Apex system, patented by Giesse, is easily and quickly mounted on the sash profile after doing the appropriate machining.

The possible range of the telescopic slider is from 16 mm to 35 mm.

The pins to be used to transfer the motion from the cremone sliders to the rod depend on the specific geometry of the profile and must be chosen from the available ones listed below.

Materials

Handle in painted die-cast aluminium

Case and cover screws made of painted die-cast zamak

Spring made of steel and screw made of zinc plated steel

Shim in Hostaform

Rotor, racks and sliders in die-cast zamak

00964

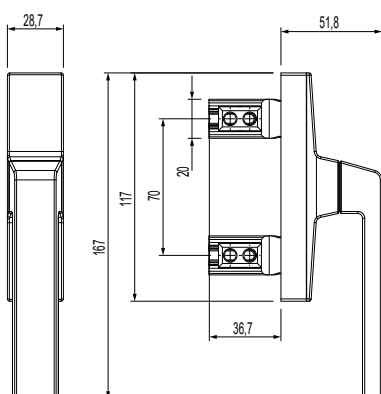
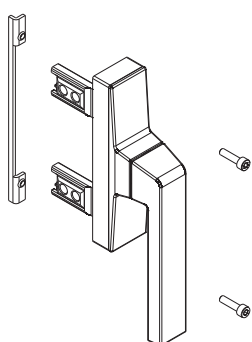

Connection pin

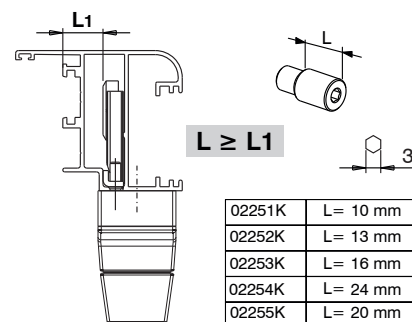

00965

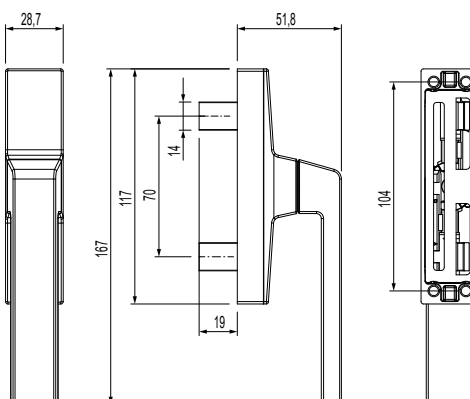
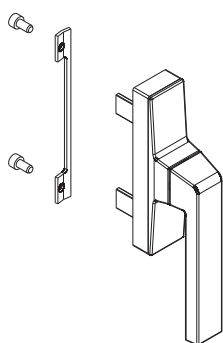

Item code	Description	PROFILE CROSS - SECTION	Hand	C/C distances	Base Raw	Anodised Elox	Painted	Trend/Gold Brass	Pieces per pack
00964	KORA 0-180 APEX CREMONE	C001-C002-C003-C004-C005-C006-C007-C008-C009-C010-C012-C013-C014-C015-C016-C017		104 mm	X		X		10
00965	KORA 0-180 CREMONE	C001-C002-C003-C004-C005-C006-C007-C008-C009-C010-C012-C013-C014-C015-C016-C017		104 mm	X		X		10



KORA KEY 0-180 CREMONE

Functions

Reversible cremone, with key lockable handle, with rotation through 90°, 135° (micro-ventilation version) and 180° and opening/closing positioning notch.

Online data sheet



Technical Features

The use of high quality die-cast materials and the GIESSE painting system guarantee excellent mechanical performance, together with colour uniformity and good abrasion resistance.

The cylinders of the KORA KEY 0-180 cremones have homogeneous coding, on request it is in any case possible to fulfill specific job orders with customized coding.

Materials

Handle in die-cast aluminium
 Die-cast Zamak case, gears, racks and sliding parts
 Nickel-plated brass cylinder
 Hostaform plate
 Spring, screws and fixing plate in stainless steel

00967

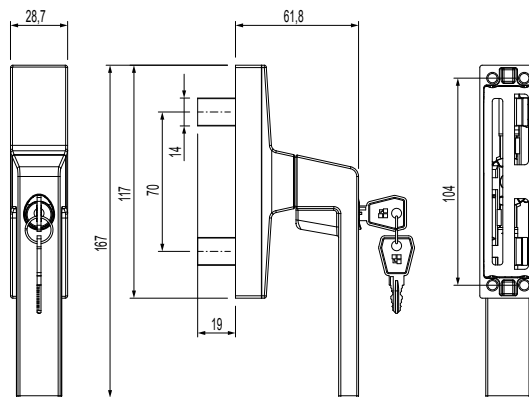
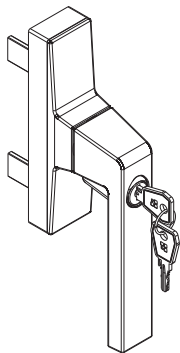

Item code	Description	PROFILE CROSS - SECTION	Hand	C/C distances	Base Raw	Anodised Elox	Painted	Trend/Gold Brass	Pieces per pack
00967	KORA KEY 0-180 CREMONE	C001-C002-C003-C004-C005-C006-C007-C008-C009-C010-C012-C013-C014-C015-C016-C017		104 mm	X		X		5

KORA CW CREMONE

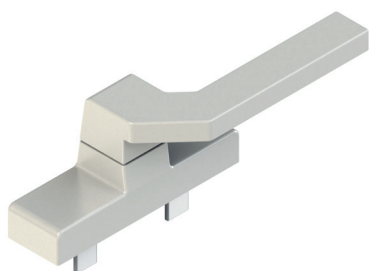

Functions

Cremone for curtain walls with 90° (two-way) and opening/closing positioning notch.

Online data sheet



Technical Features

The use of high quality die-cast materials and the GIESSE painting system guarantee excellent mechanical performance, together with colour uniformity and good abrasion resistance.

KORA CW cremones are designed for installation with C/C distance of 104 mm and 92 mm, but can easily be adapted for fixing with a C/C distance of 98 mm. The special form of the pull handle makes it easy to insert the hand, thus allowing the handling of large-size sashes.

Materials

Handle in die-cast aluminium
Cremone case, gear, racks and sliding parts in die-cast zamak.

Offset block and plate in die-cast zamak
Hostaform internal sheathing
Spring, screw and fixing plate in stainless steel

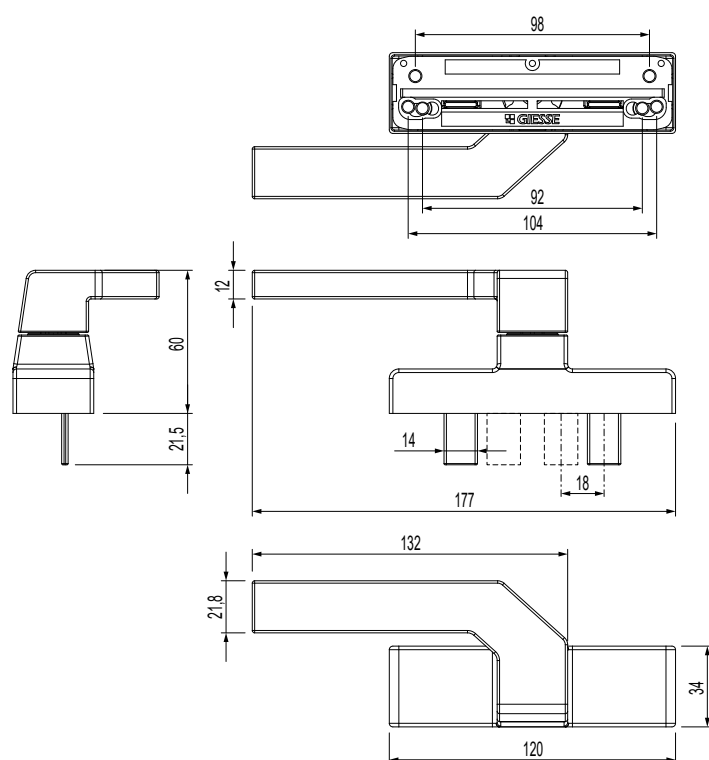

C/C distance machining 104 mm

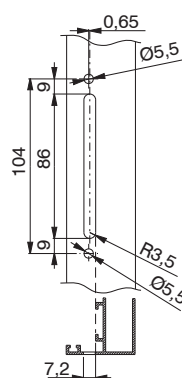

C/C distance machining 92 mm

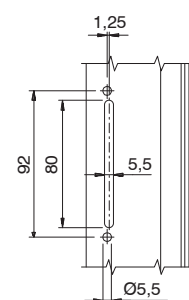

C/C distance machining 98 mm

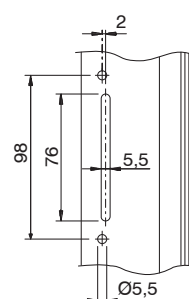

Item code	Description	Version	Hand	C/C distances	Operation	Pull handle 0°	Pull handle 90°	Base Raw	Anodised Elox	Painted	Trend/Gold Brass	Pieces per pack
009691	KORA CW CREMONE		RX	104 - 92 - 98	two-way	closed	open	X		X		10

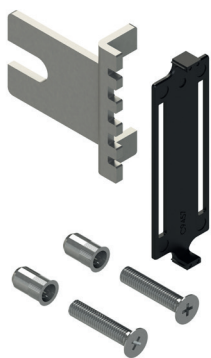

KORA 0-90 OUTWARD OPENING KIT

Functions

Components that, added to the Kora 0-90 Cremona, without internal components, enable converting it into the finished product.

Online data sheet



Technical features

Completion kit that allows you to connect the cremona to the rod for fastening the window.

Composed of the internal components and fixing components (screws and rivets) that must be suitably mounted by the window maker.

Materials

Black polyamide plate

Slider, screws and rivets of galvanized steel

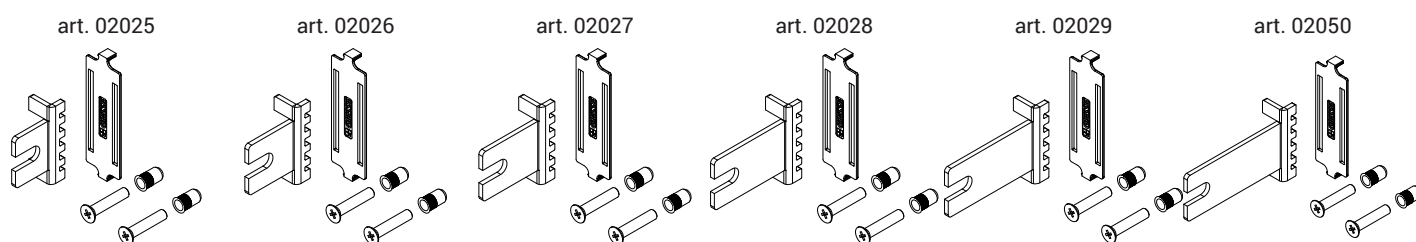

L= Slider length

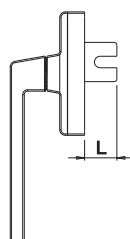

Item code	Description	Slider length	Base Raw	Anodised Elox	Painted	Trend/Gold Brass	Pieces per pack
02025	OUTWARD OPENING KIT	20 mm	X				10
02026	OUTWARD OPENING KIT	28 mm	X				10
02027	OUTWARD OPENING KIT	35 mm	X				10
02028	OUTWARD OPENING KIT	45 mm	X				10
02029	OUTWARD OPENING KIT	55 mm	X				10
02050	OUTWARD OPENING KIT	65 mm	X				10

EURO CREMONE



Functions

Reversible cremone handle for operating GIESSE Sash, Tilt-and-Turn Window and Tilt-and-Turn Window with Microventilation mechanisms.

Online data sheet



Technical Features

The use of high quality die-cast materials and the GIESSE painting system guarantee excellent mechanical performance, together with colour uniformity and good abrasion resistance.

Depending on the version, they are available with snap positioning of the pull handle at 0°, 90°, 135° and 180°.

The EURO cremone is supplied pre-assembled right-handed.

Available in both one-way and two-way versions.

Depending on the version, the C/C distances of 84, 92, 96, 98, 104 and 130 mm are possible.

Materials

Handle in die-cast aluminium
 Cremone case, gear racks in die-cast zamak
 Internal sheath and Hostaform plate
 Spring, screws and fixing plate in stainless steel

Parts

- 1 fixing plate
- 2 HSHC screws M5x14

A. One-way version

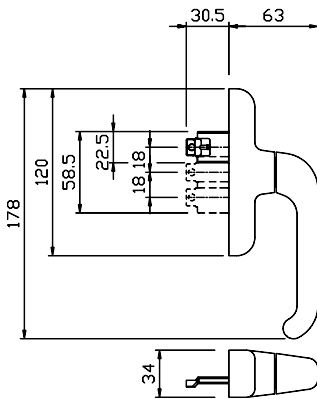

B. One-way version

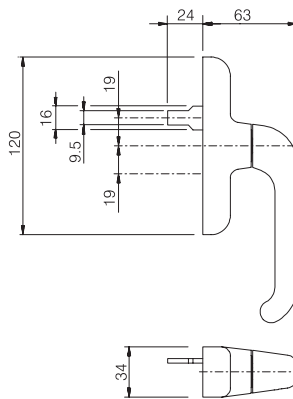

C. One-way version

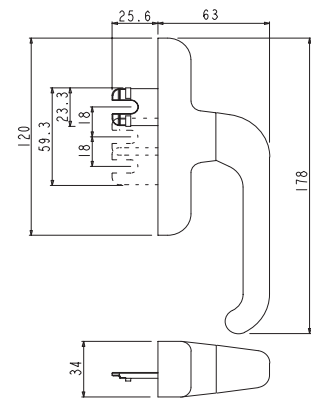

D. Two-way version (C/C distance 84.5 - 98 - 104 mm)

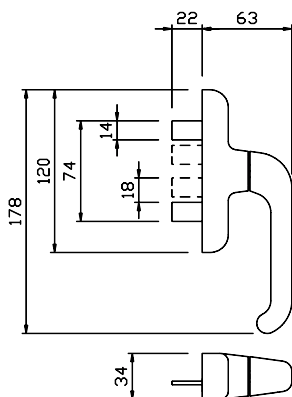

E. Two-way version (C/C distance 130 mm)

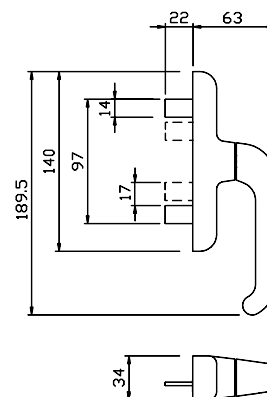

C/C distance machining 104 mm

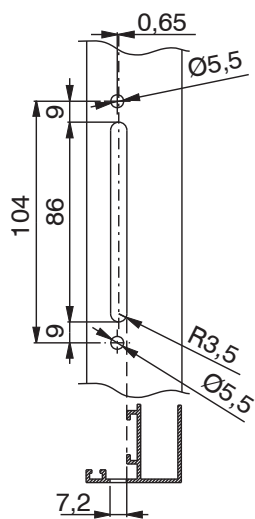

C/C distance machining 84.5 mm

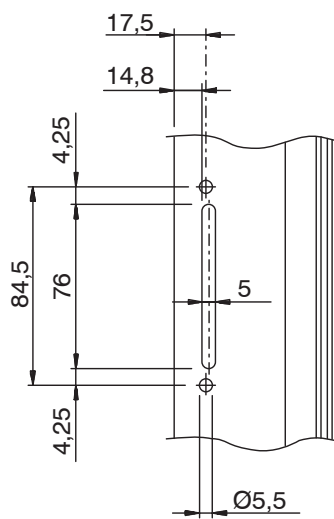

C/C distance machining 98 mm

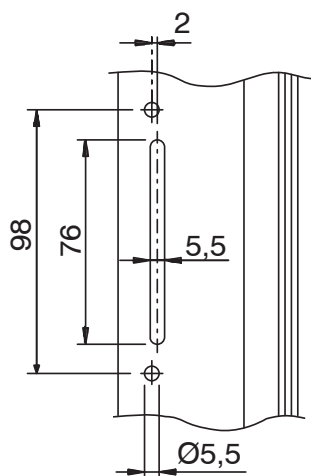

C/C distance machining 96 mm

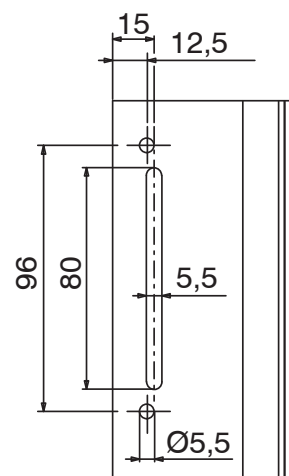

C/C distance machining 92 mm

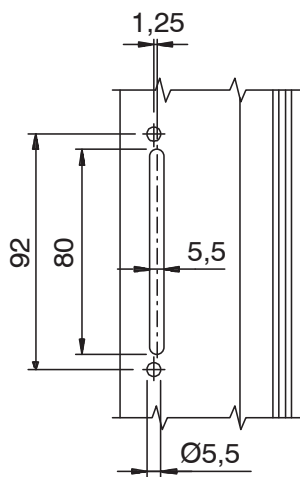

C/C distance machining 130 mm

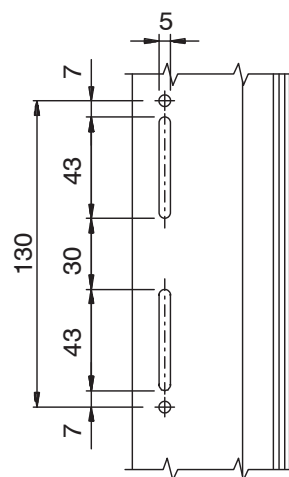

CREMONES

Item code	Description	PROFILE CROSS - SECTION	Type	C/C distances	Operation	Figure	Pull handle 0°	Pull handle 90°	Pull handle 135°	Pull handle 180°	Base Raw	Anodised Elox	Painted	Trend/Gold Brass	Pieces per pack
01000U	EURO CREMONE	C001-C002-C003-C004-C005-C006-C007-C008-C009-C010-C012-C013-C014-C015-C016-C017-P001-P002-P004-P005-P006-P007-P008-P009-P010	Sash	104 - 98 - 84	Two-way	D	Closed	open	-	-	X		X	X	10
01008	EURO CREMONE	C001-C002-C003-C004-C005-C006-C007-C008-C009-C010-C012-C013-C014-C015-C016-C017-P001-P002-P004-P005-P006-P007-P008-P009-P010	Sash	130	Two-way	E	Closed	open	-	-	X		X		20
01094	EURO 900 MICRO CREMONE	C001-C002-C003-C004-C005-C006-C012-C013-C014-C015-C016-C017	Tilt-and-turn window (microventilation)	104 - 98 - 84	One-way	A	Closed	open	Micro	bot-tom-hung windows	X		X		10
01108	EURO 900 CREMONE	C001-C002-C003-C004-C005-C006-C007-C008-C009-C010-C012-C013-C014-C015-C016-C017	Tilt-and-turn window	98	One-way	B	Closed	open	-	bot-tom-hung windows	X		X		20
01109	EURO 900 CREMONE	C001-C002-C003-C004-C005-C006-C007-C008-C009-C010-C012-C013-C014-C015-C016-C017	Tilt-and-turn window	104 - 98 - 84	One-way	C	Closed	open	-	bot-tom-hung windows	X		X		20



EURO KEY CREMONE

Functions

Reversible cremone handle, with key lockable pull handle, with 90° rotation (side-hung window) or 90° and 180° (tilt-and-turn window) and opening/closing positioning notch.

Online data sheet



Technical Features

The use of high quality die-cast materials and the GIESSE painting system guarantee excellent mechanical performance, together with colour uniformity and good abrasion resistance.

The EURO KEY cremones, supplied right-hand, have a fixing C/C distance of 104 mm and 84 mm, but can be easily adapted for mounting with a C/C distance of 98 mm.

Uses a cylinder made to European standard dimensions. When necessary you can replace the cylinder, product 01045.

Materials

Handle in die-cast aluminium
 Cremone case and gear in die-cast zamak
 Internal sheath and Hostaform plate
 Spring, screws and fixing plate in stainless steel
 Brass cylinder

Parts

- 1 fixing plate
- 2 HSHC screws M5x14
- 3 Keys

One-way version

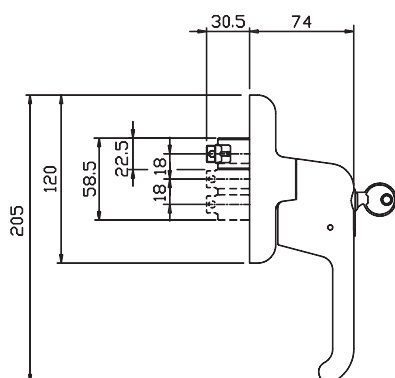

Two-way

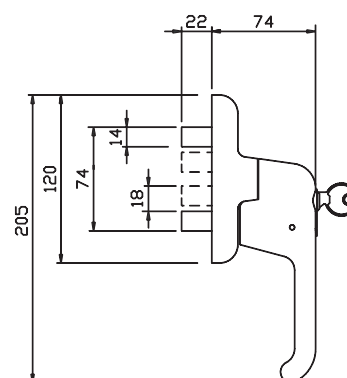

C/C distance machining 84.5 mm

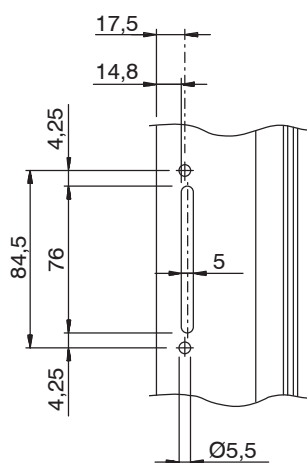

C/C distance machining 98 mm

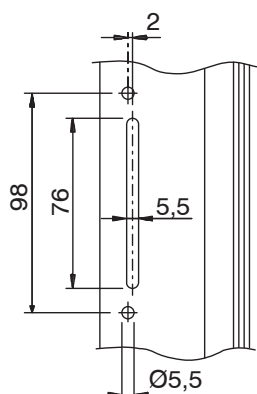

C/C distance machining 104 mm

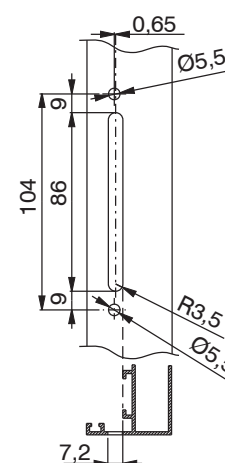

CREMONES

Item code	Description	PROFILE CROSS - SECTION	Type	C/C distances	Operation	Pull handle 0°	Pull handle 90°	Pull handle 180°	Base Raw	Anodised Elox	Painted	Trend/Gold Brass	Pieces per pack
01002	EURO KEY CREMONE	C001-C002-C003-C004-C005-C006-C007-C008-C009-C010-C012-C013-C014-C015-C016-C017-P001-P002-P004-P005-P006-P007-P008-P009-P010	Sash	104 - 98 - 84	Two-way	Closed	Open	-	X		X		5
01092K	EURO KEY CREMONE	C001-C002-C003-C004-C005-C006-C007-C008-C009-C010-C012-C013-C014-C015-C016-C017	Tilt-and-turn window	104 - 98 - 84	One-way	Closed	Open	Bottom-hung windows	X		X		5



EURO UNIVERSAL CREMONE

Functions

Reversible cremone handle for central gasket systems with one-way mechanism, equipped with 90°, 135° (microventilation) and 180° rotation and snap positioning.

Online data sheet



Technical Features

The use of high quality die-cast materials and the GIESSE painting system guarantee excellent mechanical performance, together with colour uniformity and good abrasion resistance.

The cremone is specific to one-way mechanisms such as the tilt-and-turn window and for the side-hung window it also enables using micro-ventilation.

Product designed as part of the GIESSE SPACE Project, for use in combination with GIESSE automatic machines.

The incorrect movement safety device necessary for tilt-and-turn windows is contained in the SPAZIO GIESSE tilt-and-turn mechanism.

Available also in a version with the Rapid 104 hook, which is a patented system, fast both to assemble and disassemble.

Materials

Handle in die-cast aluminium
Cremone case, gear, racks and sliding parts in die-cast zamak

Internal sheath and Hostaform plate

Spring, screw and fixing plate in stainless steel

Parts

1 fixing plate

2 HSHC screws M5x14

Version for sash and tilt-and-turn windows

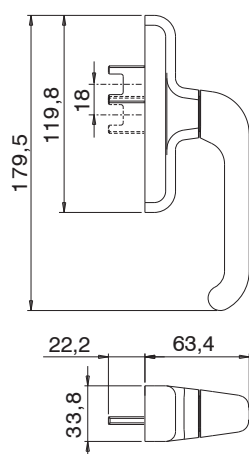

C/C distance machining 84.5 mm

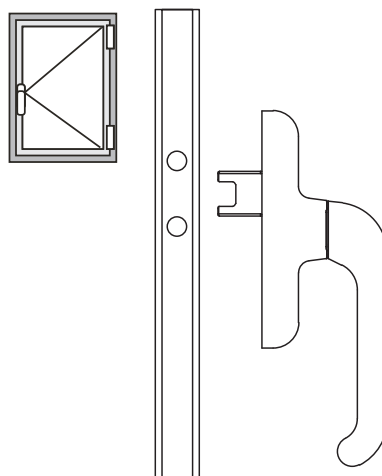
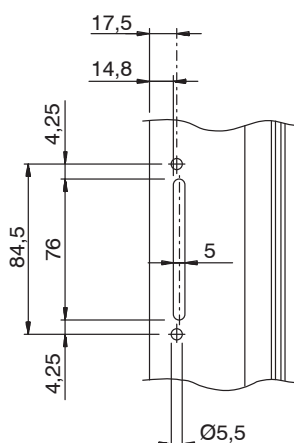

C/C distance machining 98 mm

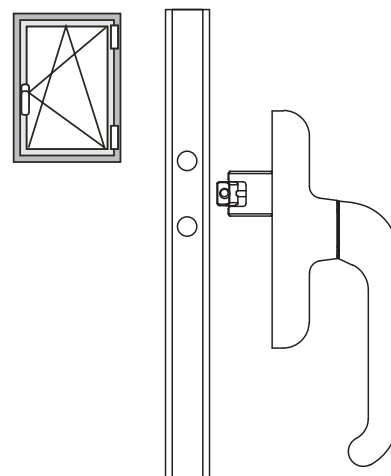

C/C distance machining 104 mm

CREMONES

Item code	Description	PROFILE CROSS - SECTION	Version	C/C distances	Base Raw	Anodised Elox	Painted	Trend/Gold Brass	Pieces per pack
01037	EURO UNIVERSAL CREMONE	C001-C002-C003-C004-C005-C006-C007-C008-C009-C010-C012-C013-C014-C015-C016-C017	Micro-ventilation	104 - 98 - 84			X		10
01057R	EURO UNIVERSAL CREMONE (RAPID 104)	C001-C002-C003-C004-C005-C006-C007-C008-C009-C010-C012-C013-C014-C015-C016-C017	Rapid	104	X		X		10



EURO AWAY CREMONE

Functions

Reversible cremone handle for operating the GIESSE Sash and Tilt-and-Turn Window mechanisms. Enables operating casements and removing the handle for security requirements.

Online data sheet



Technical Features

The use of high quality die-cast materials and the GIESSE painting system guarantee excellent mechanical performance, together with colour uniformity and good abrasion resistance.

Depending on the version, they are available with snap positioning of the pull handle at 0°, 90° and 180°.

The EURO AWAY cremone, supplied right-handed, has fixing C/C distance of 104 mm (for alternative C/C distance see the table).

Available in both one-way and two-way versions.

For use in combination with the adjustable pull handle art. 01130.

Materials

Cremone case, gear
Racks and die-cast zamak sliders
Internal sheath and Hostaform plate
Stainless steel screws and fixing plate
Away turret and cap in black polyamide

Parts

1 fixing plate
2 HSHC screws M5x14

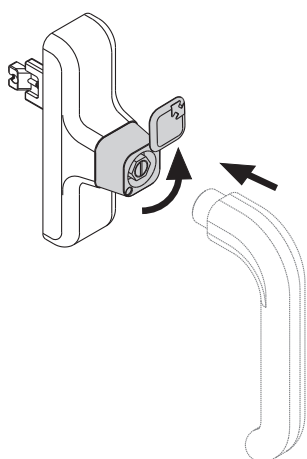

C/C distance machining 104 mm

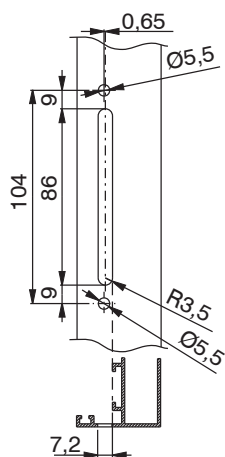

Sash version

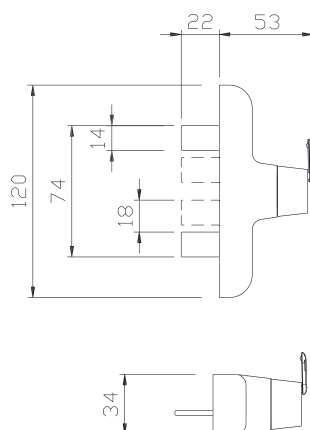

C/C distance machining 84.5 mm

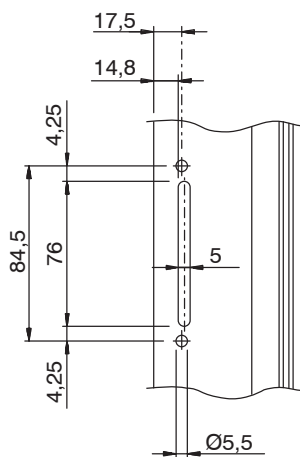

Tilt-and-turn window version

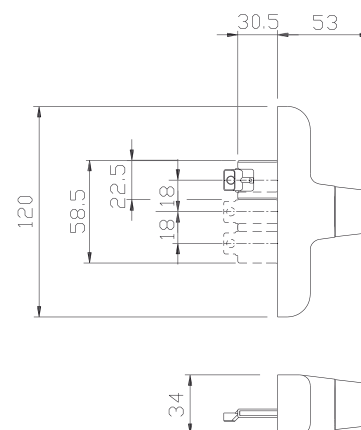

C/C distance machining 98 mm

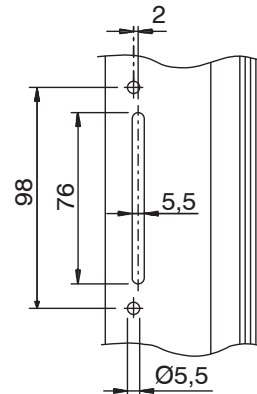

CREMONES

Item code	Description	PROFILE CROSS - SECTION	Version	C/C distances	Operation	Pull handle 0°	Pull handle 90°	Pull handle 180°	Base Raw	Anodised Elox	Painted	Trend/Gold Brass	Pieces per pack
01001	EURO AWAY CREMONE	C001-C002-C003-C004-C005-C006-C007-C008-C009-C010-C012-C013-C014-C015-C016-C017-P001-P002-P004-P005-P006-P007-P008-P009-P010	Sash	104 - 98 - 84	Two-way	Closed	Open	-	X		X		5
01091K	EURO AWAY CREMONE	C001-C002-C003-C004-C005-C006-C007-C008-C009-C010-C012-C013-C014-C015-C016-C017	Tilt-and-turn window	104 - 98 - 84	One-way	Closed	Open	Bottom-hung windows	X		X		5
01130	EURO REMOVABLE PULL HANDLE	C001-C002-C003-C004-C005-C006-C007-C008-C009-C010-C012-C013-C014-C015-C016-C017-P001-P002-P004-P005-P006-P007-P008-P009-P010	-	-	-	-	-	-	X				1

EURO CW CREMONE



Functions

Cremone for curtain walls with 90° (two-way) and opening/closing positioning notch.

Online data sheet



Technical Features

The use of high quality die-cast materials and the GIESSE painting system guarantee excellent mechanical performance, together with colour uniformity and good abrasion resistance.

EURO CW cremones are designed for installation with C/C distance 98 mm, but can easily be adapted for fixing with a C/C distance of 104 mm and 84 mm. The special form of the pull handle makes it easy to insert the hand, thus allowing the handling of large-size sashes.

Materials

Handle in die-cast aluminium
Cremone case, gear, racks and sliding parts in die-cast zamak.

Offset block and plate in die-cast zamak

Hostaform internal sheathing

Spring, screw and fixing plate in stainless steel

050072 - LX

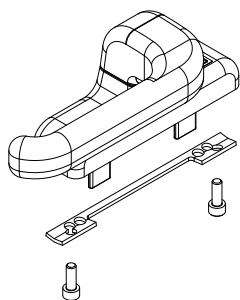

050071 - RX

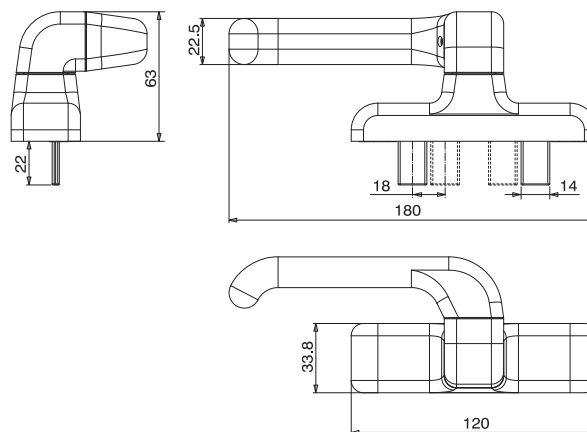
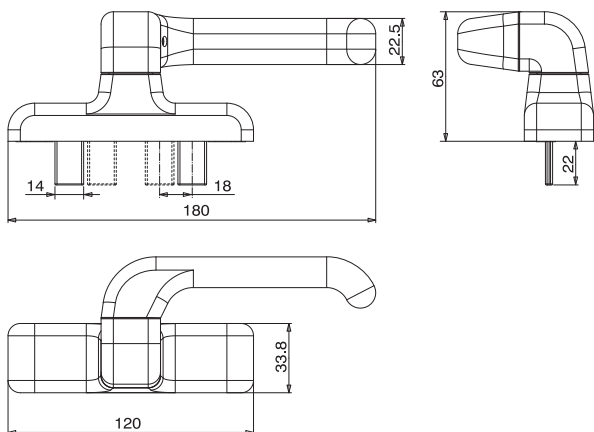
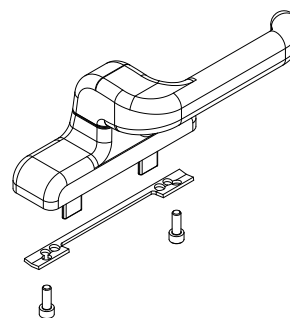

05008

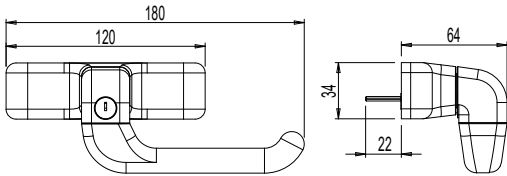
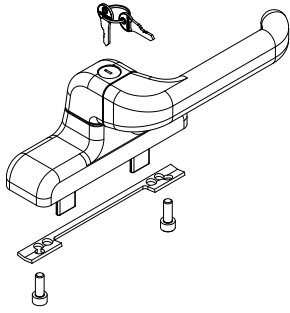

C/C distance machining 84.5 mm

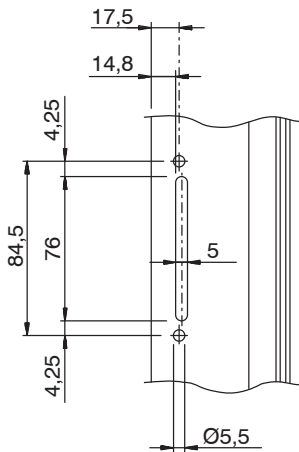

050081

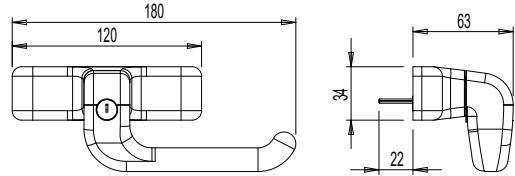
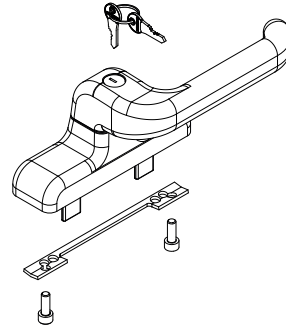

C/C distance machining 98 mm

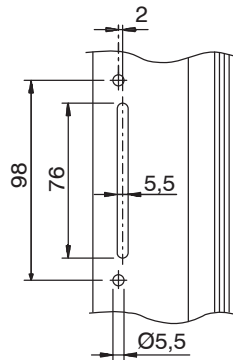

C/C distance machining 104 mm

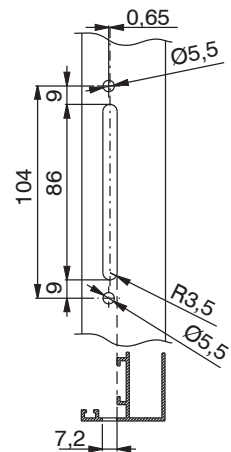

Item code	Description	Version	Hand	C/C distances	Operation	Pull handle 0°	Pull handle 90°	Base Raw	Anodised Elox	Painted	Trend/Gold Brass	Pieces per pack
050071	EURO CW2 CREMONE-RIGHT		rx	104 - 98 - 84	two-way	Closed	open	X		X		5
050072	EURO CW2-LEFT CREMONE		lx	104 - 98 - 84	two-way	Closed	open	X		X		5
05008	EURO KEY CW2 CREMONE	Key	RH (reversible)	104 - 98 - 84	two-way	Closed	open	X		X		5
050081	EURO KEY CW2 CREMONE-RIGHT	Key	rx	104 - 98 - 84	two-way	Closed	open	X		X		5

EURO CREMONE FOR PARALLEL CURTAIN WALL



Functions

Cremone, in right and left versions, for Parallel outward opening curtain wall windows.

Online data sheet



Technical Features

The cremones, placed on the sash uprights, are operated simultaneously by means of a bar, supplied in different lengths and to be cut to size, that connects them.

This bar-cremone connection system enables a dual function:

1. The cremones are operated simultaneously, for locking/unlocking the locking points.
2. The sash is opened and closed by pushing or pulling the bar.

Making a complete closing system requires:

- Cremone – 2 pcs
- Connection bar – 1 pc
- Connection components (block or mechanism) – 2 pcs
- Fastening components to choose from those applicable to the profile used

Materials

Handle in die-cast aluminium
 Cremone case, gear racks in die-cast zamak
 Internal sheath and Hostaform plate
 Spring, screws and fixing plate in stainless steel

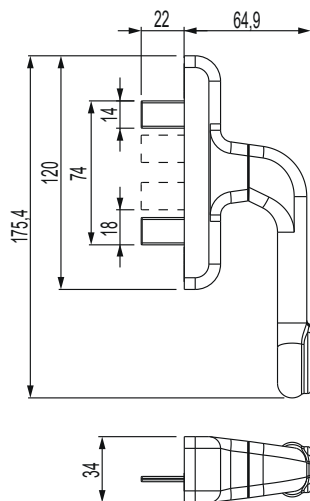

Bar fixing with screws

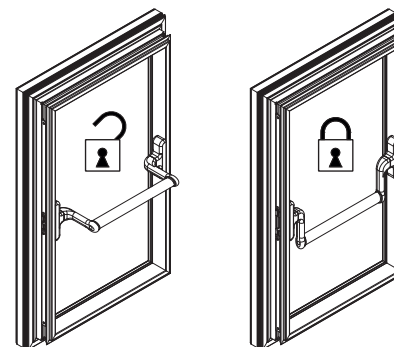
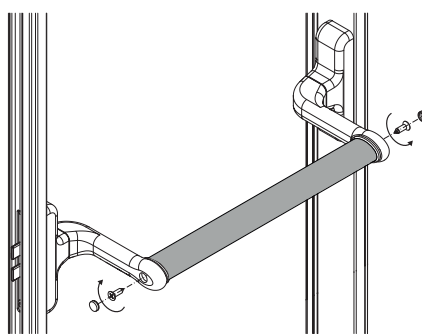

Item code	Description	PROFILE CROSS - SECTION	Type	C/C distances	Operation	Pull handle 0°	Pull handle 90°	Base Raw	Anodised Elox	Painted	Trend/Gold Brass	Pieces per pack
00993	EURO CREMONE FOR PARALLEL CURTAIN WALL	C001-C002-C003-C004-C005-C006-C007-C008-C009-C010-C012-C013-C014-C015-C016-C017	Parallel sash	104 - 98 - 84	Two-way	Closed	open	X		X		5

Item code	Description	Type of Fixing	Length	Base Raw	Anodised Elox	Painted	Trend/Gold Brass	Pieces per pack
04157	BAR	Screws	1200 mm			X		1
04158	BAR	Screws	1800 mm			X		1

PRIMA CREMONE

Functions

Reversible cremone handle for operating the GIESSE Sash, Tilt-and-Turn Window and Tilt-and-Turn Window with Microventilation mechanisms.

Online data sheet



Technical Features

The use of high quality die-cast materials, together with the GIESSE painting system, guarantees excellent mechanical performance, as well as colour uniformity and strong resistance to abrasion.

Depending on the version, they are available with snap positioning of the pull handle at 0°, 90°, 135° and 180°.

The PRIMA cremone is supplied pre-assembled right-handed.

Available in both one-way and two-way versions.

Depending on the version, the C/C distances of 84, 98 and 104 mm are possible.

Materials

Handle in die-cast aluminium
Cremone case, gear, racks and sliding parts in die-cast zamak

Internal sheath and Hostaform plate

Spring, screws and fixing plate in stainless steel

On the Brass version, the case and handle are made of brass

Parts

1 fixing plate

2 HSHC screws M5x14

Version for sash

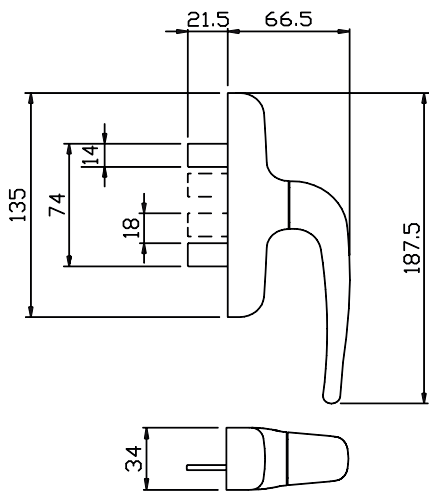

Version for tilt-and-turn window

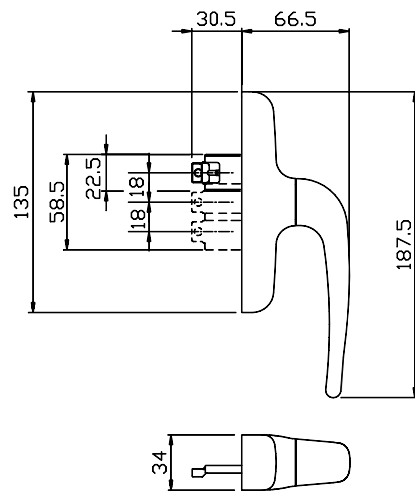

C/C distance machining 104 mm

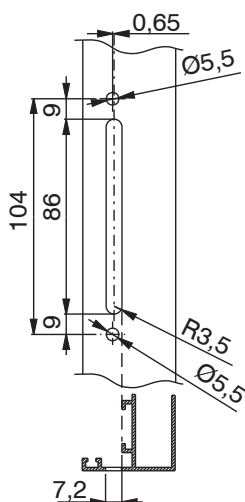

C/C distance machining 98 mm

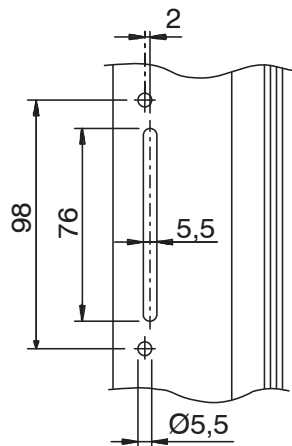

C/C distance machining 84.5 mm

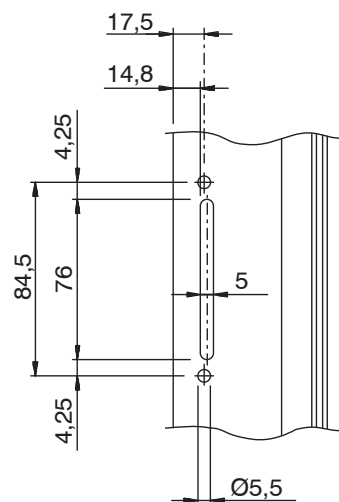

Item code	Description	PROFILE CROSS - SECTION	Material	Type	C/C distances	Operation	Pull handle 0°	Pull handle 90°	Pull handle 135°	Pull handle 180°	Base Raw	Anodised Elox	Painted	Trend/Gold Brass	Pieces per pack
01024U	PRIMA CREMONE	C001-C002-C003-C004-C005-C006-C007-C008-C009-C010-C012-C013-C014-C015-C016-C017-P001-P002-P004-P005-P006-P007-P008-P009-P010		Sash	104 - 98 - 84	two-way	closed	open			X		X		10
01039	PRIMA CREMONE	C001-C002-C003-C004-C005-C006-C007-C008-C009-C010-C012-C013-C014-C015-C016-C017		Tilt-and-turn window (microventilation)	104 - 98 - 84	one-way	closed	open	micro	bot-tom-hung windows	X		X		10
01120	PRIMA CREMONE	C001-C002-C003-C004-C005-C006-C007-C008-C009-C010-C012-C013-C014-C015-C016-C017	Brass	Tilt-and-turn window (microventilation)	104 - 98 - 84	one-way	closed	open	micro	bot-tom-hung windows				X	2
01121	PRIMA CREMONE	C001-C002-C003-C004-C005-C006-C007-C008-C009-C010-C012-C013-C014-C015-C016-C017-P001-P002-P004-P005-P006-P007-P008-P009-P010	Brass	Sash	104 - 98 - 84	two-way	closed	open						X	2



PRIMA KEY CREMONE

Functions

Reversible cremone handle, with key lockable pull handle, with 90° rotation (side-hung window) or 90° and 180° (tilt-and-turn window) and opening/closing positioning notch.

Online data sheet



Technical Features

The use of high quality die-cast materials and the GIESSE painting system guarantee excellent mechanical performance, together with colour uniformity and good abrasion resistance.

The cylinders of the FIRST KEY cremones have homogeneous coding, on request it is in any case possible to fulfill specific job orders with customized coding.

The cylinder of the PRIMA KEY Logica and Microventilation cremones has the Giesse Key Capture system.

The cylinder, depending on the version, allows locking the handle of the cremone to 90°, 135° and 180°. When the handle is at 90° or 135° it is possible to remove the key and then leave the sash in the tilt-and-turn or micro-ventilation position, in safety.

When the pull handle is at 180°, and therefore the sash is in the fully open position, it is not possible to remove the key from the cylinder.

Materials

Handle in die-cast aluminium
Die-cast Zamak case, gears, racks and sliding parts

Nickel-plated brass cylinder

Internal sheath and Hostaform plate

Spring, screws and fixing plate in stainless steel

Parts

1 fixing plate

2 HSHC screws M5x14

Two-way version

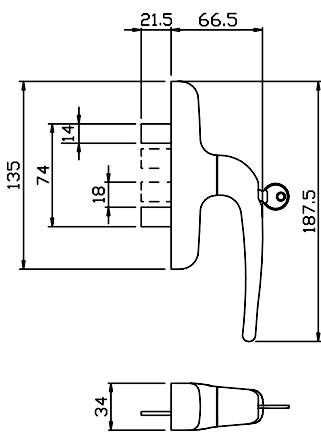

C/C distance machining 84.5 mm

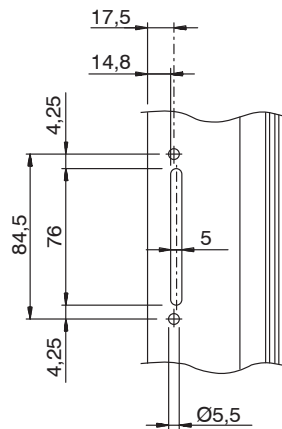

C/C distance machining 92 mm

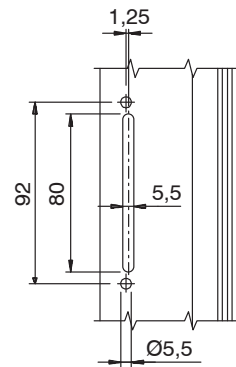

One-way version

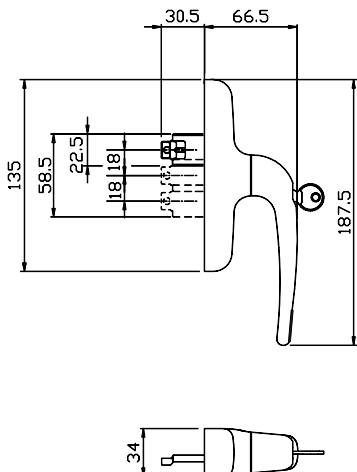

C/C distance machining 98 mm

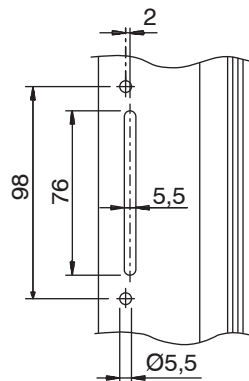

C/C distance machining 104 mm

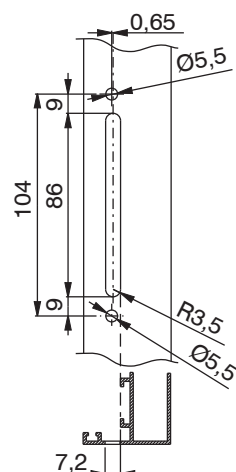

Item code	Description	PROFILE CROSS - SECTION	Material	Type	Version	C/C distances	Performance	Operation	Pull handle 0°	Pull handle 90°	Pull handle 135°	Pull handle 180°	Base Raw	Anodised Elox	Painted	Trend/Gold Brass	Pieces per pack
01011	PRIMA KEY CREMONE	C001-C002-C003-C004-C005-C006-C007-C008-C009-C010-C012-C013-C014-C015-C016-C017-P001-P002-P004-P005-P006-P007-P008-P009-P010		Sash		104 - 98 - 92 - 84	> 100 N/m	Two-way	Closed	Open	-	-	X		X	X	5
01019	PRIMA KEY CREMONE	C001-C002-C003-C004-C005-C006-C007-C008-C009-C010-C012-C013-C014-C015-C016-C017-P001-P002-P004-P005-P006-P007-P008-P009-P010	Brass	Sash		104 - 98 - 84		Two-way	Closed	Open	-	-				X	2
0114901	PRIMA KEY CAPTURE CREMONE	C001-C002-C003-C004-C005-C006-C007-C012-C013-C014-C015-C016-C017		Tilt-and-turn window	Logica	104 - 92		One-way	Closed	Bot-tom-hung windows	-	Open key not remova-ble	X		X	X	5
0119102	SKG PRIMA KEY MICRO CREMONE	C001-C002-C003-C004-C005-C006-C007-C008-C009-C010-C012-C013-C014-C015-C016-C017		Tilt-and-turn window	Micro	104 - 98 - 92 - 84	> 100 N/m	One-way	Closed	Open	Micro	Bot-tom-hung windows	X		X	X	5
01192	PRIMA KEY CAPTURE LGC CREMONE	C001-C002-C003-C004-C005-C006-C007-C012-C013-C014-C015-C016-C017		Tilt-and-turn window	Logica	104 - 92	> 100 N/m	One-way	Closed	Bot-tom-hung windows	-	Open key not remova-ble	X		X		5
01193	PRIMA KEY CAPTURE LGC CREMONE	C001-C002-C003-C004-C005-C006-C007-C012-C013-C014-C015-C016-C017		Tilt-and-turn window	Logica - Micro	104 - 98 - 92 - 84	> 100 N/m	One-way	Closed	Bot-tom-hung windows	Micro	Open key not remova-ble	X		X		5
01194	PRIMA KEY CAPTURE MICRO CREMONE	C001-C002-C003-C004-C005-C006-C007-C012-C013-C014-C015-C016-C017		Tilt-and-turn window	Logica - Micro	104 - 92	> 100 N/m	One-way	Closed	Bot-tom-hung windows	Micro	Open key not remova-ble	X		X	X	5
01209	PRIMA KEY CAPTURE 104-92 CREMONE	C001-C002-C003-C004-C005-C006-C007-C012-C013-C014-C015-C016-C017		Tilt-and-turn window	Logica - handle 200 mm	104 - 92	> 100 N/m	One-way	Closed	Bot-tom-hung windows	-	Open key not remova-ble			X		5



PRIMA UNIVERSAL CREMONE

Functions

Reversible cremone handle for central gasket systems with one-way mechanism, equipped with 90°, 135° (microventilation) and 180° rotation and snap positioning.

Online data sheet



Technical Features

The use of high quality die-cast materials and the GIESSE painting system guarantee excellent mechanical performance, together with colour uniformity and good abrasion resistance.

The cremone is specific to one-way mechanisms such as the tilt-and-turn window and for the side-hung window it also enables using micro-ventilation. Product designed as part of the GIESSE SPACE Project, for use in combination with GIESSE automatic machines.

The incorrect movement safety device necessary for tilt-and-turn windows is contained in the SPAZIO GIESSE tilt-and-turn mechanism.

Available also in a version with the Rapid 104 hook, which is a patented system, fast to assemble.

Materials

Handle in die-cast aluminium
Cremone case, gear, racks and sliding parts in die-cast zamak

Internal sheath and Hostaform plate

Spring, screw and fixing plate in stainless steel

Parts

1 fixing plate

2 HSHC screws Mx14

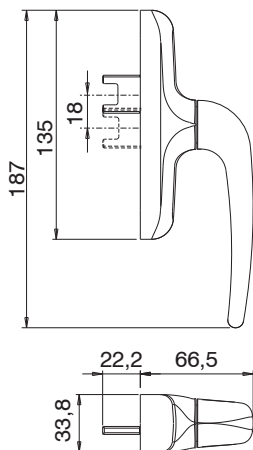

C/C distance machining 84.5 mm

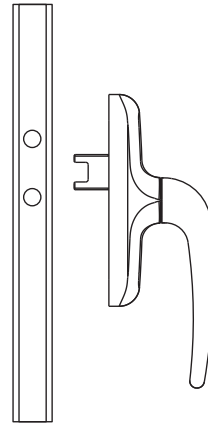
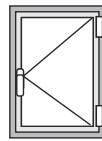
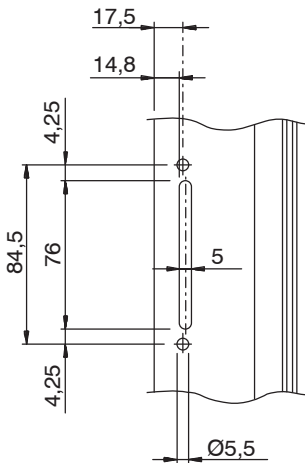

C/C distance machining 98 mm

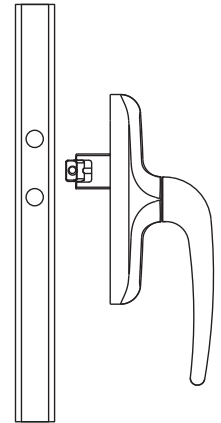
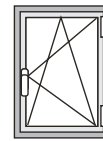
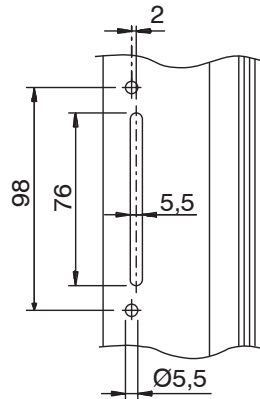

C/C distance machining 104 mm

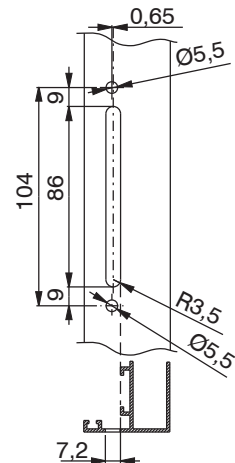

Item code	Description	PROFILE CROSS - SECTION	Material	Version	C/C distances	Base Raw	Anodised Elox	Painted	Trend/Gold Brass	Pieces per pack
01038	PRIMA UNIVER.MICROVENTILATION CREMONE	C001-C002-C003-C004-C005-C006-C007-C008-C009-C010-C012-C013-C014-C015-C016-C017		Micro-ventilation	104 - 98 - 84	X		X		10
01058R	PRIMA UNIVERSAL CREMONE (RAPID 104)	C001-C002-C003-C004-C005-C006-C007-C008-C009-C010-C012-C013-C014-C015-C016-C017		Rapid	104	X		X		10

ASIA CREMONE

Functions

Reversible cremone handle for operating the GIESSE Sash, Tilt-and-Turn Window and Tilt-and-Turn Window with Microventilation mechanisms.

Online data sheet

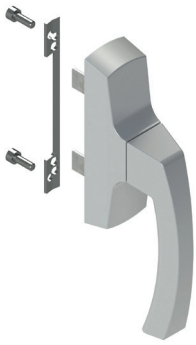

Technical Features

The use of high quality die-cast materials and the GIESSE painting system guarantee excellent mechanical performance, together with colour uniformity and good abrasion resistance.

The Asia cremone has a fixing C/C distance of 104 mm and 92 mm, but can be easily adapted for fixing with a C/C distance of 84 and 98 mm.

Materials

Handle in die-cast aluminium
 Cremone case, gear racks in die-cast zamak
 Internal sheath and Hostaform plate
 Steel spring
 Stainless steel screws and fixing plate

Overall dimensions of cremone for sash

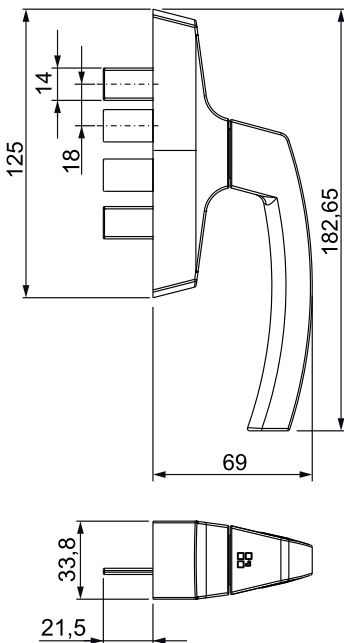

Overall dimensions of cremone for MP tilt-and-turn

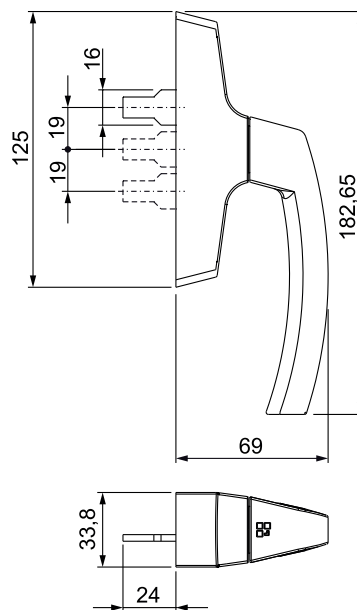

Overall dimensions of cremone for tilt-and-turn

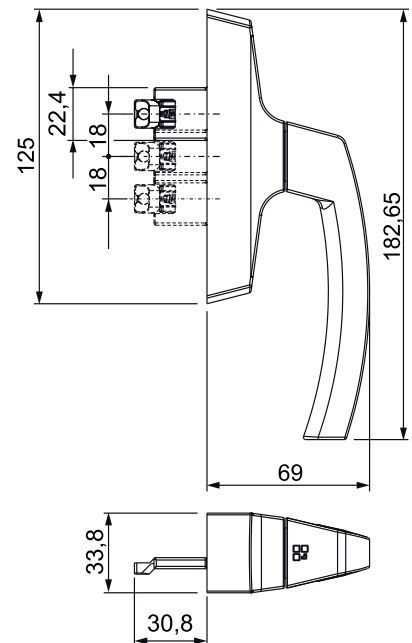

C/C distance machining 98 mm

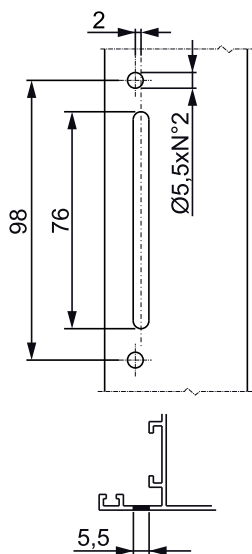

C/C distance machining 84.5 mm

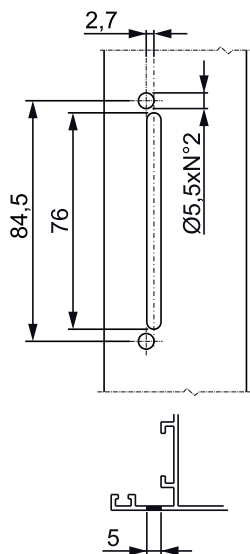

C/C distance machining 104 mm

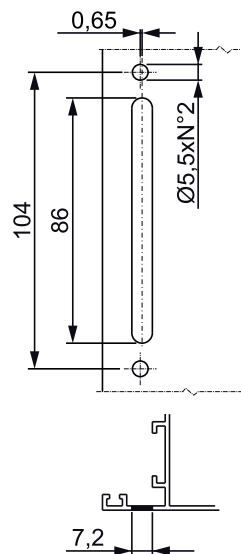

C/C distance machining 92 mm

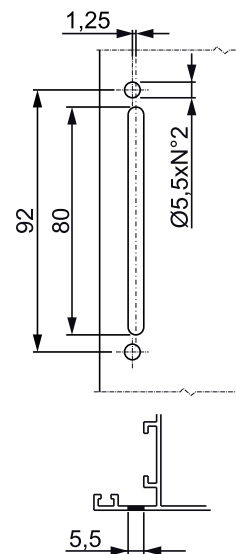

Item code	Description	PROFILE CROSS - SECTION	Type	C/C distances	Operation	Pull handle 0°	Pull handle 90°	Pull handle 135°	Pull handle 180°	Base Raw	Anodised Elox	Painted	Trend/Gold Brass	Pieces per pack
01064	ASIA MP CREMONE	-	Tilt-and-turn window	104 - 98 - 92 - 84	one-way	closed	open	-	bot-tom-hung windows	X		X		20
01076	ASIA CREMONE	C001-C003-P002-P006	Sash	104 - 98 - 92 - 84	two-way	closed	open	-	-	X		X		10
01084	ASIA CREMONE	C001-C002-C003-C004-C005-C006-C007-C008-C009-C010-C012-C013-C014-C015-C016-C017	Tilt-and-turn window (microventilation)	104 - 98 - 92 - 84	one-way	closed	open	micro	bot-tom-hung windows	X		X	X	10

ASIA KEY CREMONE

Functions

Reversible cremone, with key lockable handle, with rotation through 90°, 135° (micro-ventilation version) and 180° and opening/closing positioning notch.

Online data sheet



Technical Features

The use of high quality die-cast materials and the GIESSE painting system guarantee excellent mechanical performance, together with colour uniformity and good abrasion resistance.

The cylinders of the ASIA KEY cremones have homogeneous coding, on request it is in any case possible to fulfill specific job orders with customized coding.

The cylinder of the ASIA KEY Logica and Microventilation Logica cremones has the Giesse Key Capture system.

The cylinder, depending on the version, allows locking the handle of the cremone to 90°, 135° and 180°. When the handle is at 90° or 135° it is possible to remove the key and then leave the sash in the tilt-and-turn or micro-ventilation position, in safety.

When the pull handle is at 180°, and therefore the sash is in the fully open position, it is not possible to remove the key from the cylinder.

Materials

- Handle in die-cast aluminium
- Die-cast Zamak case, gears, racks and sliding parts
- Nickel-plated brass cylinder
- Hostaform plate
- Spring, screws and fixing plate in stainless steel

Overall dimensions art. 01065

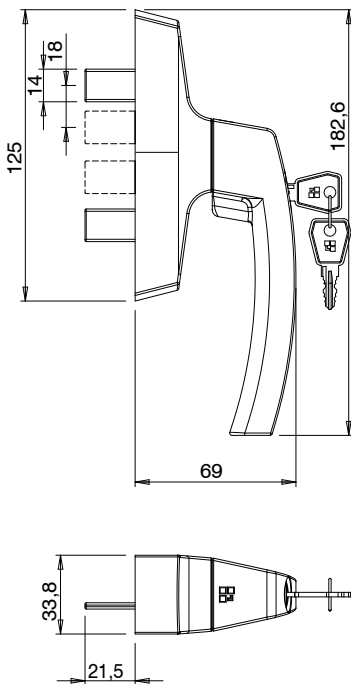

Overall dimensions art. 01085

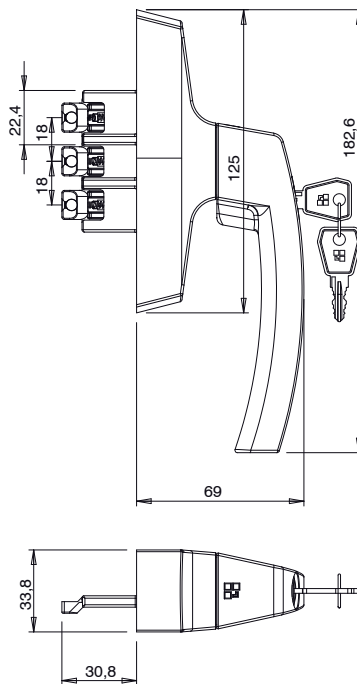

Overall dimensions art. 01196

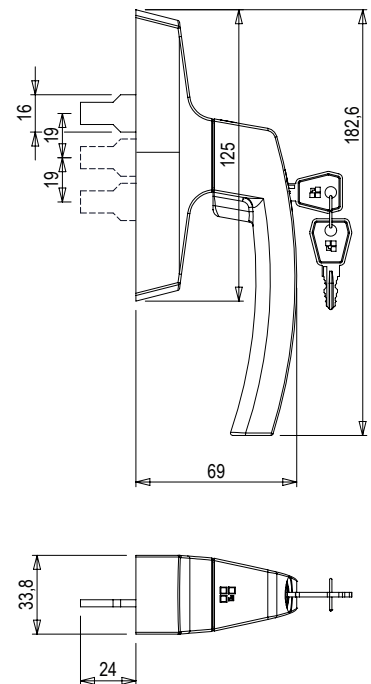

C/C distance machining 84.5 mm

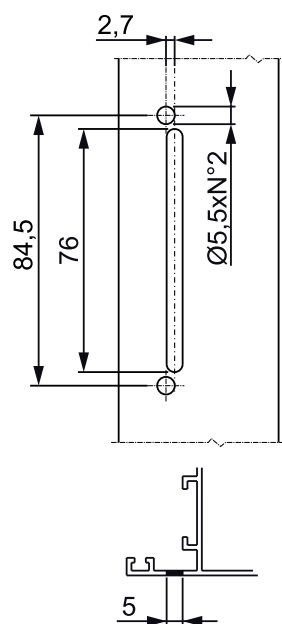

C/C distance machining 92 mm

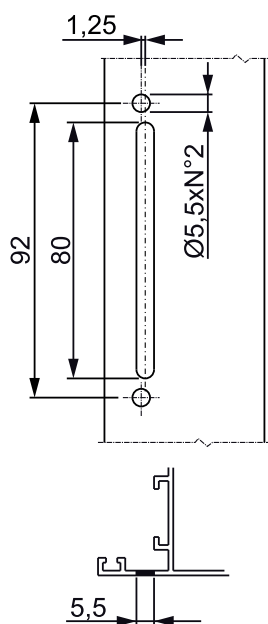

C/C distance machining 98 mm

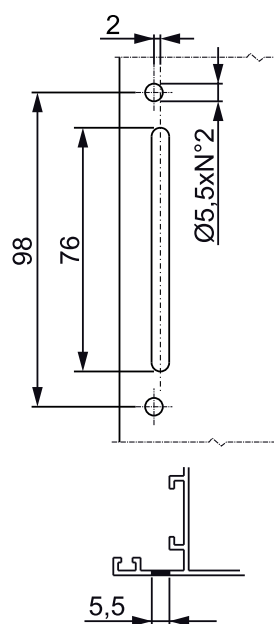

C/C distance machining 104 mm

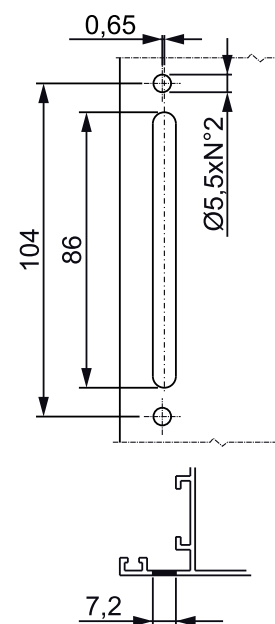

Item code	Description	PROFILE CROSS-SECTION	Type	Version	C/C distances	Performance	Operation	Pull handle 0°	Pull handle 90°	Pull handle 135°	Pull handle 180°	Base Raw	Anodised Elox	Painted	Trend/Gold Brass	Pieces per pack
01065	ASIA KEY CREMONE	C001-C002-C003-C004-C005-C006-C007-C008-C009-C010-C012-C013-C014-C015-C016-C017-P001-P002-P004-P005-P006-P007-P008-P009-P010	Sash	-	104 - 98 - 92 - 84	> 100 N/m	two-way	closed	open	-	-	X		X		5
0108501	SKG ASIA KEY MICRO CREMONE	C001-C002-C003-C005-C006-C013-C014-C015-C016-C017	Tilt-and-turn window	Micro	104 - 98 - 92 - 84	> 100 N/m	one-way	closed	open	micro	bot-tom-hung windows	X		X	X	5
01086	ASIA KEY CAPTURE LGC CREMONE	C001-C002-C003-C004-C005-C006-C007-C012-C013-C014-C015-C016-C017	Tilt-and-turn window	Logica	104 - 92	> 100 N/m	one-way	closed	bot-tom-hung windows	-	open	X		X		5
01087	ASIA KEY CAPTURE MICRO CREMONE	C001	Tilt-and-turn window	Micro	104 - 92	> 100 N/m	one-way	closed	bot-tom-hung windows	micro	open	X		X		5
01196	ASIA KEY T/T MONOPINNA CREMONE	C001-C002-C003-C004-C005-C006-C007-C008-C009-C010-C012-C013-C014-C015-C016-C017-P001-P002-P004-P005-P006-P007-P008-P009-P010	Tilt-and-turn window	-	104 - 98 - 92 - 84	> 100 N/m	One-way	closed	open	-	bot-tom-hung windows	X		X		5



ASIA UNIVERSAL CREMONE

Functions

Reversible cremone for central gasket systems with one-way mechanism, equipped with 90°, 180° rotation and positioning notch.

Online data sheet



Technical Features

The cremone is specific to one-way closing systems such as tilt-and-turn and side-hung.
 Product designed as part of the GIESSE SPACE Project, for use in combination with GIESSE automatic machines.
 The incorrect movement safety device necessary for tilt-and-turn windows is contained in the SPAZIO GIESSE tilt-and-turn mechanism.
 The use of high quality die-cast materials and the GIESSE painting system guarantee excellent mechanical performance, together with colour uniformity and good abrasion resistance.

Materials

Handle in die-cast aluminium
 Cremone case, gear, racks and sliding parts in die-cast zamak
 Internal sheath and Hostaform plate
 Spring, screw and fixing plate in stainless steel

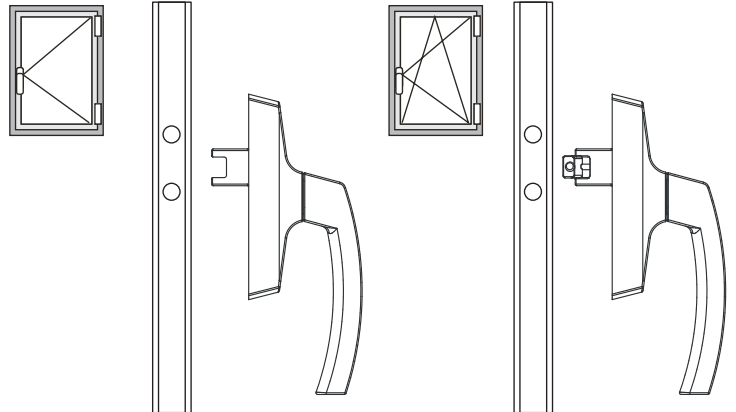
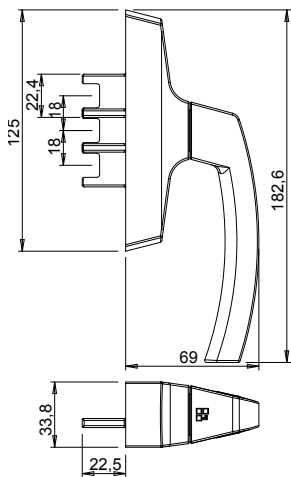

C/C distance machining 84.5

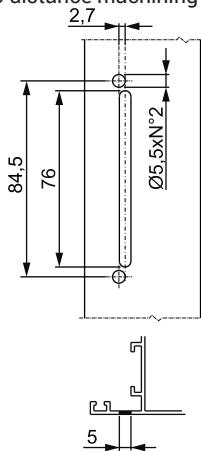

C/C distance machining 98

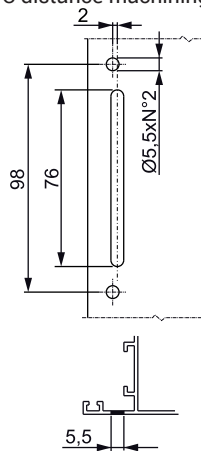

C/C distance machining 104

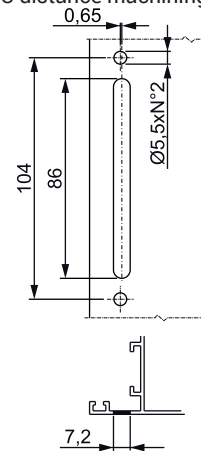

Item code	Description	PROFILE CROSS - SECTION	C/C distances	Operation	Base Raw	Anodised Elox	Painted	Trend/Gold Brass	Pieces per pack
01005	ASIA UNIVERSAL CREMONE	C001-C002-C003-C004-C005-C006-C007-C008-C009-C010-C012-C013-C014-C015-C016-C017	104 - 98 - 84	one-way	X		X		10

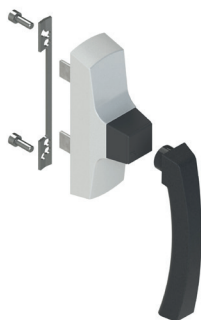

ASIA AWAY CREMONE

Functions

Reversible cremone handle for operating GIESSE Sash and Tilt-and-Turn with micro-ventilation mechanisms. Enables operating casements and removing the handle for security requirements.

Online data sheet



Technical Features

The use of high quality die-cast materials and the GIESSE painting system guarantee excellent mechanical performance, together with colour uniformity and good abrasion resistance.

Depending on the version, they are available with snap positioning of the handle at 0°, 90°, 135° and 180°.

The ASIA cremone is supplied pre-assembled right-handed.

Available in both one-way and two-way versions.

The Asia cremone has a fixing C/C distance of 104 mm and 92 mm, but can be easily adapted for fixing with a C/C distance of 84 and 98 mm.

For use in combination with the removable handle.

Materials

Cremone case, gear racks in die-cast zamak

Internal sheath and Hostaform plate

Stainless steel screws and fixing plate

Away turret and cap in black polyamide

Handle in die-cast aluminium

Overall dimensions art. 01078

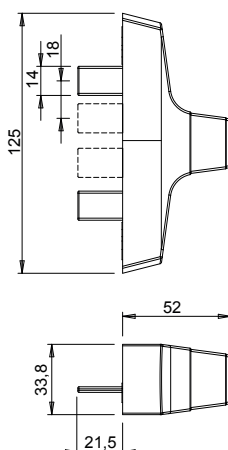
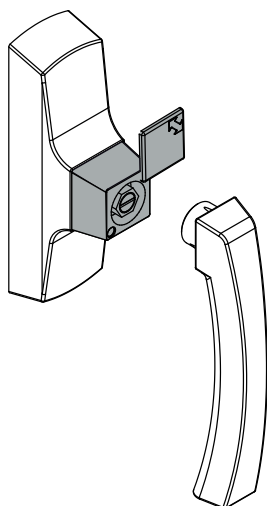

Overall dimensions art. 01079

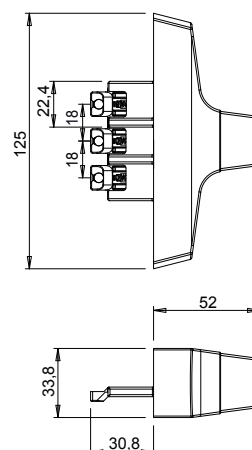

C/C distance machining 84.5 mm

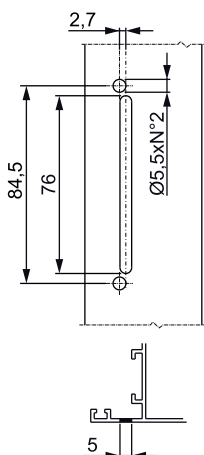

C/C distance machining 92 mm

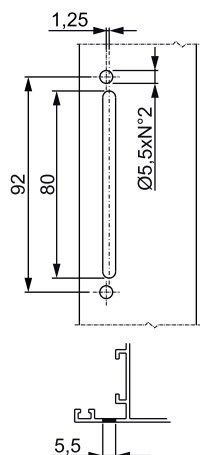

C/C distance machining 98 mm

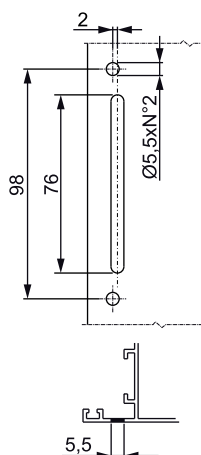

C/C distance machining 104 mm

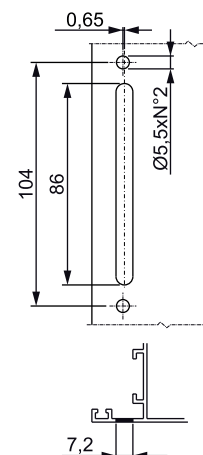

CREMONES

Item code	Description	PROFILE CROSS - SECTION	Type	C/C distances	Operation	Pull handle 0°	Pull handle 90°	Pull handle 135°	Pull handle 180°	Base Raw	Anodised Elox	Painted	Trend/Gold Brass	Pieces per pack
01078	ASIA AWAY CRE-MONE	C001-C002-C003-C004-C005-C006-C007-C008-C009-C010-C012-C013-C014-C015-C016-C017	Sash	104 - 98 - 92 - 84	two-way	closed	open	-	-	X		X		10
01079	ASIA AWAY CRE-MONE	C001-C002-C003-C004-C005-C006-C007-C008-C009-C010-C012-C013-C014-C015-C016-C017-P001-P002-P004-P005-P006-P007-P008-P009-P010	Tilt-and-turn window (microventilation)	104 - 98 - 92 - 84	one-way	closed	open	micro	bot-tom-hung windows	X		X		10
01111	ASIA REMOVABLE HANDLE	C001-C002-C003-C004-C005-C006-C007-C008-C009-C010-C012-C013-C014-C015-C016-C017	-	-	-	-	-	-	-			X		1



ASIA PLUS OUTWARD 0-90° CREMONE

Functions

Reversible cremone for outward opening with space saving.

Online data sheet



Technical Features

The cremone is specific to one-way closing systems with handle positioning at 0° and 90°.

The use of high quality die-cast materials and the GIESSE painting system guarantee excellent mechanical performance, together with colour uniformity and good abrasion resistance.

The Asia Outward 0-90 cremone has a fixing C/C distance of 70 mm.

The cremone is to be matched with the outward opening casement kits and the drive rod devices.

Materials

Handle in die-cast aluminium

Case, case cover and rotor in zamak

Spring and screw of stainless steel

Dimensions art. 01401

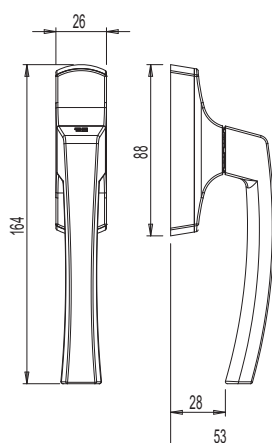

L= Slider length

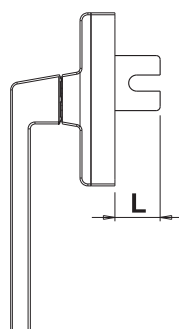

C/C distance machining 70 mm

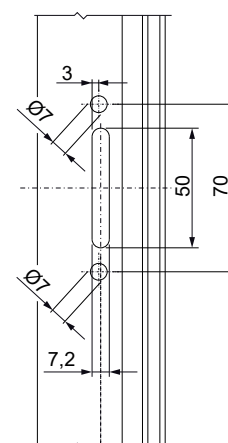

Item code	Description	Type	C/C distances	Operation	Pull handle 0°	Pull handle 90°	Base Raw	Anodised Elox	Painted	Trend/Gold Brass	Pieces per pack
01401	ASIA PLUS 0-90° OUTWARD OPENING CREMONE	Outward Opening	70	One-way	Closed	Open			X		10

Item code	Description	Slider length	Base Raw	Anodised Elox	Painted	Trend/Gold Brass	Pieces per pack
02025	OUTWARD OPENING KIT	20 mm	X				10
02026	OUTWARD OPENING KIT	28 mm	X				10
02027	OUTWARD OPENING KIT	35 mm	X				10
02028	OUTWARD OPENING KIT	45 mm	X				10
02029	OUTWARD OPENING KIT	55 mm	X				10
02050	OUTWARD OPENING KIT	65 mm	X				10

ASIA PLUS 0-90 OUTWARD OPENING KIT

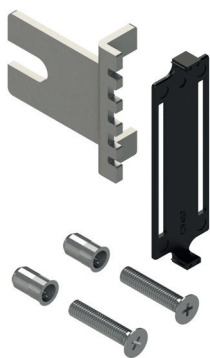

Functions

Components that, added to the Asia Plus 0-90 Cremona, without internal components, enable converting it into the finished product.

Online data sheet



Technical features

Completion kit that allows you to connect the cremone to the rod for fastening the window.

Composed of the internal components and fixing components (screws and rivets) that must be suitably mounted by the window maker.

Materials

Black polyamide plate

Slider, screws and rivets of galvanized steel

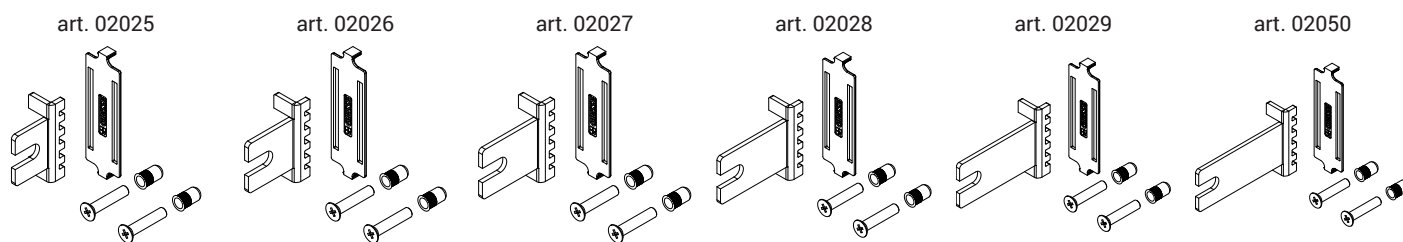

L= Slider length

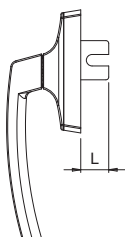

Item code	Description	Slider length	Base Raw	Anodised Elox	Painted	Trend/Gold Brass	Pieces per pack
02025	OUTWARD OPENING KIT	20 mm	X				10
02026	OUTWARD OPENING KIT	28 mm	X				10
02027	OUTWARD OPENING KIT	35 mm	X				10
02028	OUTWARD OPENING KIT	45 mm	X				10
02029	OUTWARD OPENING KIT	55 mm	X				10
02050	OUTWARD OPENING KIT	65 mm	X				10

PULL DEVICES



Functions

Components for connecting the one-way cremones to the connection rods of the window.

Online data sheet



Technical features

It is used to connect the cremones with one-way movement (in pre-assembled or disassembled versions) to the closing rod of an aluminium window. This generally concerns Shutter-type outward or Side Hung openings. The Giesse patented rod pull device has a pin of diameter 8 mm of different lengths depending on the article.

Materials

Driving pin in zamak
Rod joining plug in black polyamide

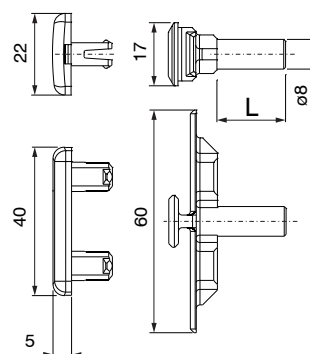
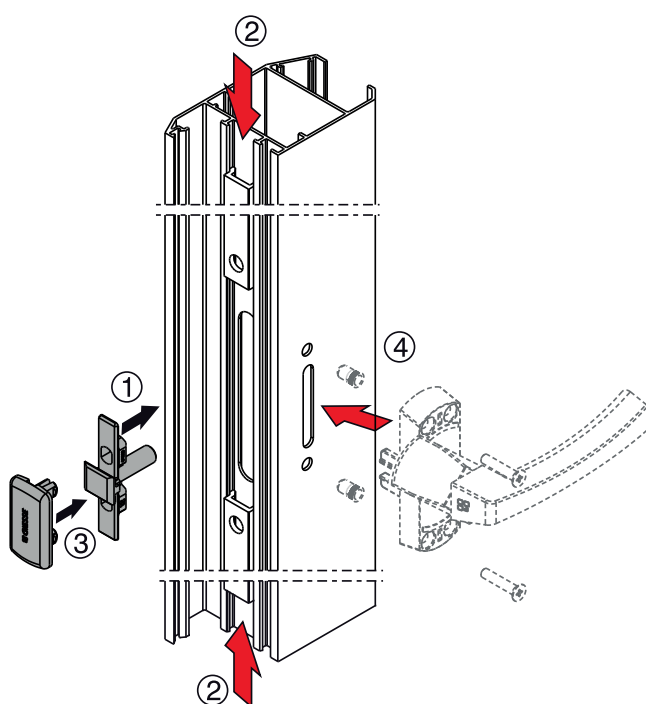

Item code	Description	Type of Opening	L pin	Rod Type	Base Raw	Anodised Elox	Painted	Trend/Gold Brass	Pieces per pack
04091	ROD PULL DEVICE	External - Shutters	40	Euro Groove	X				20
04097001	ROD PULL DEVICE	External - Shutters	26	Erre	X				20
04098001	ROD PULL DEVICE	External - Shutters	9,5	Euro Groove	X				20
04099001	ROD PULL DEVICE	External - Shutters	18,5	Euro Groove	X				20
04104	ROD PULL DEVICE	External - Shutters	19	Euro Groove	X				20
04105	ROD PULL DEVICE	External - Shutters	28	Euro Groove	X				20



ESSEN CREMONE

Functions

Reversible cremone handle for operating the GIESSE Sash and Tilt-and-Turn Window mechanisms.

[Online data sheet](#)



Technical Features

The use of high quality die-cast materials and the GIESSE painting system guarantee excellent mechanical performance, together with colour uniformity and good abrasion resistance.

The Essen cremone has a fixing C/C distance of 104 mm, but can be easily adapted for fixing with a C/C distance of 84 and 98 mm.

Materials

Handle in die-cast aluminium
 Cremone case, gear racks in die-cast zamak
 Internal sheath and Hostaform plate
 Steel spring
 Stainless steel screws and fixing plate

Overall dimensions of cremone for sash

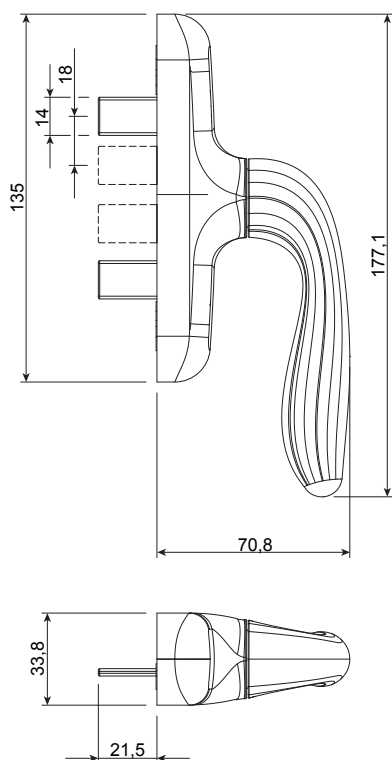

Overall dimensions of cremone for tilt-and-turn

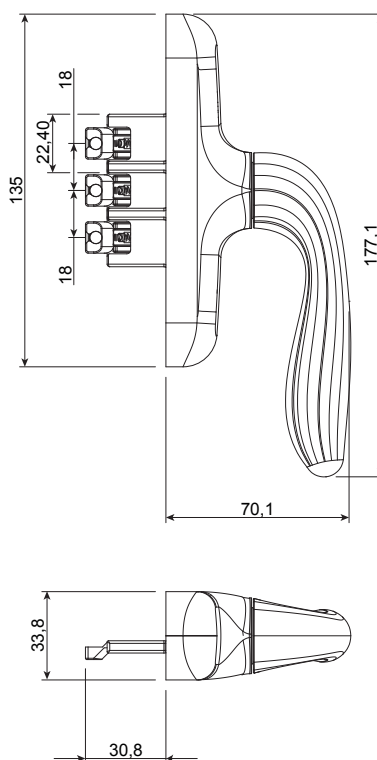

C/C distance machining 104 mm

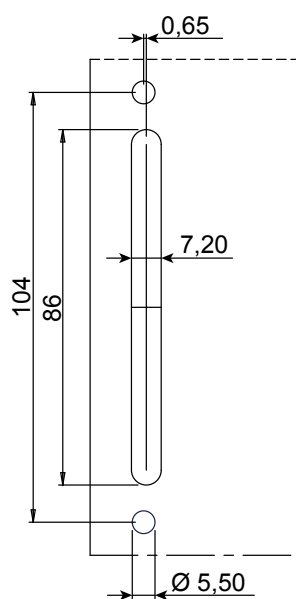

C/C distance machining 98 mm

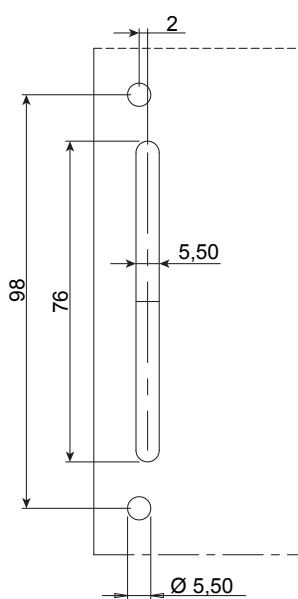

C/C distance machining 84.5 mm

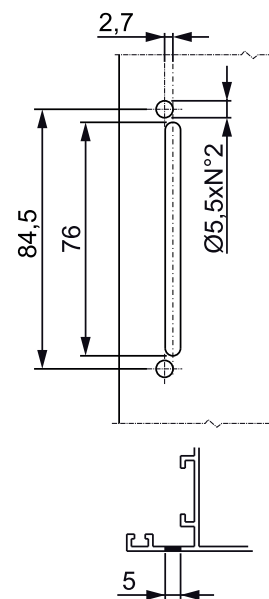

Item code	Description	PROFILE CROSS - SECTION	Material	Type	C/C distances	Operation	Pull handle 0°	Pull handle 90°	Pull handle 135°	Pull handle 180°	Base Raw Anodised Elox	Painted	Trend/Gold Brass	Pieces per pack
06980	ESSEN CREMONE	C001-C002-C003-C004-C005-C006-C007-C008-C009-C010-C012-C013-C014-C015-C016-C017-P001-P002-P004-P005-P006-P007-P008-P009-P010		Sash	104 - 98 - 84	two-way	closed	open			X	X		20
06981	ESSEN CREMONE FOR TILT-AND-TURN	C001-C002-C003-C004-C005-C006-C007-C008-C009-C010-C012-C013-C014-C015-C016-C017		Tilt-and-turn window	104 - 98 - 84	one-way	closed	open		bot-tom-hung windows	X	X		5

UNICA CREMONE

Functions

Reversible cremone handle for actioning Giese mechanisms.

Online data sheet



Technical Features

With the Unica Cremone it is possible to have the same stylish operation on casements for Inward Opening, Outward Opening and Tilt-and-Turn Window Shutter.

The Unica cremone, supplied right-handed, has a fixing C/C distance of 104 mm.

Available both with two-way and one-way mechanism, with handle positioning notches at 0°, 90° and 180° and in the APEX version.

The Unica Apex Cremone can be fitted on shutter profiles or with outward opening and does not require using the internal connection kit.

The Apex system, patented by Giese, is easily and quickly mounted on the sash profile after doing the appropriate machining.

The possible range of the telescopic slider is from 16 mm to 35 mm.

The pins to be used to transfer the motion from the cremone sliders to the rod depend on the specific geometry of the profile and must be chosen from the available Giese ones.

Materials

Handle in painted die-cast aluminium

Case in paint-finished die-cast zamak

Steel spring

Zinc plated steel screw

Shim in Hostaform

Rotor, racks and sliders in die-cast zamak.

Art. 01154001

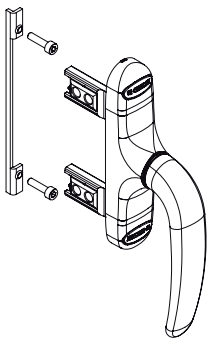

Art. 01155001

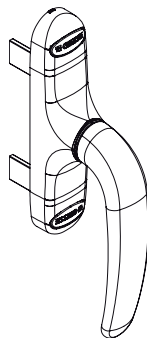

Art. 01157001

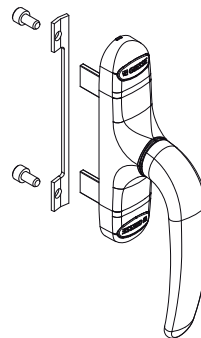

Art. 01159001

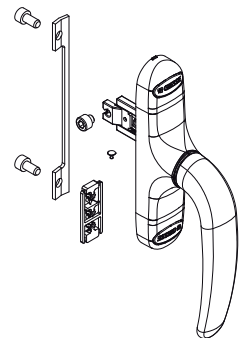

Art. 01154001

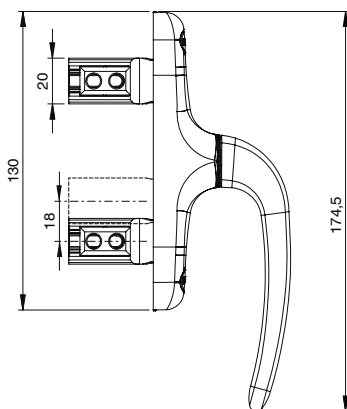

Art. 01155001

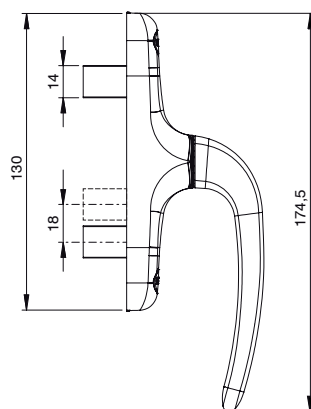

Art. 01157001

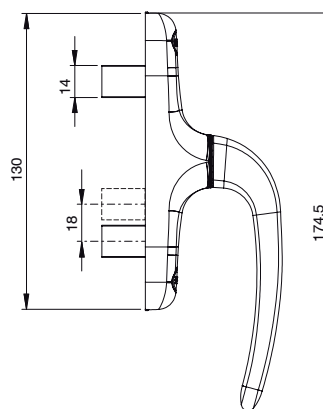

Art. 01159001

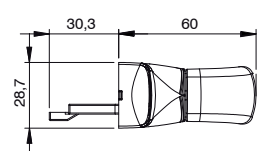
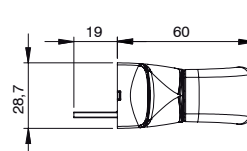
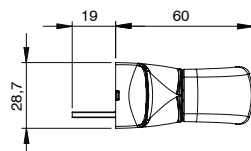
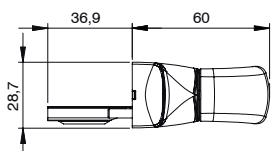
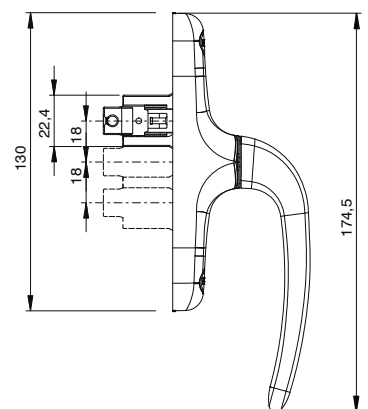

Art. 01164N

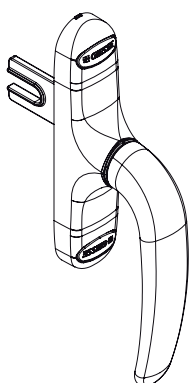

Art. 01165N

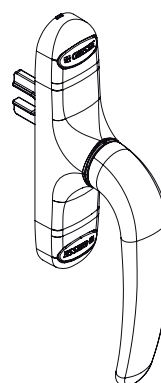

Art. 01164N

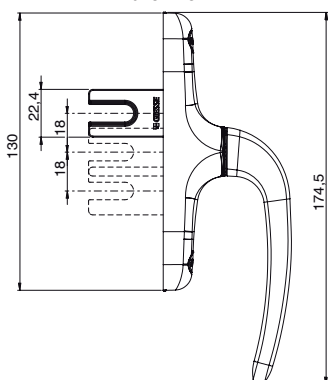

Art. 01165N

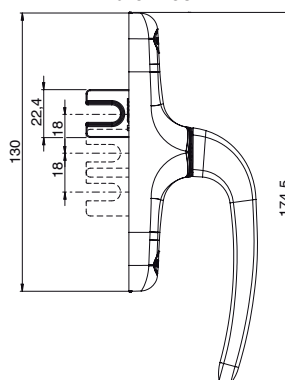

Cremone machining art. 01154001, 01155001

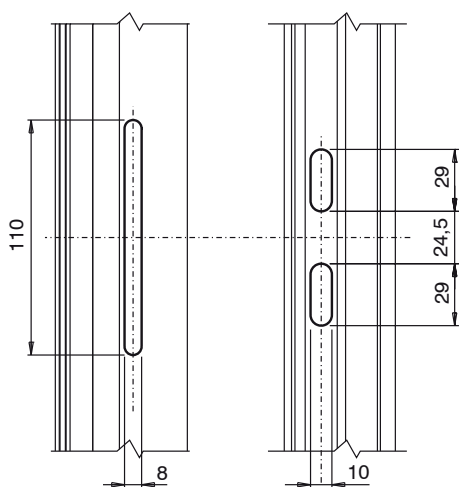

Cremone machining art. 01164N, 01165N

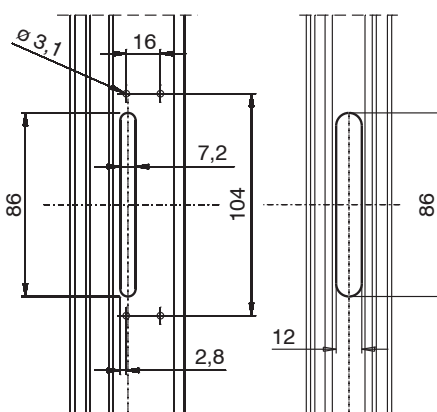

Cremone machining art. 01157001, 01159001

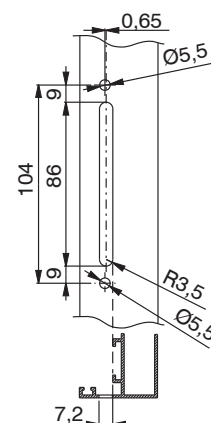

CREMONES

Item code	Description	Notes	PROFILE CROSS - SECTION	Type of Opening	Operation	Pull handle 0°	Pull handle 90°	Pull handle 180°	Base Raw	Anodised Elox	Painted	Trend/Gold Brass	Pieces per pack
01154001	UNICA APEX CREMONE	-	-	External - Shutters	Two-way	closed	open		X		X	X	10
01155001	UNICA CREMONE	-	-	External - Shutters	Two-way	closed	open				X	X	10
01157001	UNICA CREMONE	-	C001-C002-C003-C004-C005-C006-C007-C008-C009-C010-C012-C013-C014-C015-C016-C017-P001-P002-P004-P005-P006-P007-P008-P009-P010	Internal	Two-way	closed	open		X		X	X	10
01159001	UNICA CREMONE	-	C001-C002-C003-C004-C005-C006-C007-C008-C009-C010-C012-C013-C014-C015-C016-C017	Tilt-and-turn window	One-way	closed	open	bottom-hung windows	X		X	X	10
01164N	UNICA ONE-WAY CREMONE	Slider length 35 mm	-	External - Shutters	One-way	closed	open		X		X	X	20
01165N	UNICA ONE-WAY CREMONE	Slider length 20 mm	-	External - Shutters	One-way	closed	open		X		X		10

PULL DEVICES



Functions

Components for connecting the one-way cremones to the connection rods of the window.

Online data sheet



Technical features

It is used to connect the cremones with one-way movement (in pre-assembled or disassembled versions) to the closing rod of an aluminium window. This generally concerns Shutter-type outward or Side Hung openings. The Giesse patented rod pull device has a pin of diameter 8 mm of different lengths depending on the article.

Materials

Driving pin in zamak
Rod joining plug in black polyamide

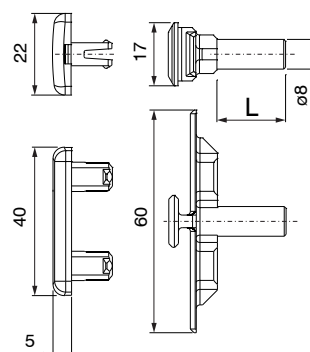
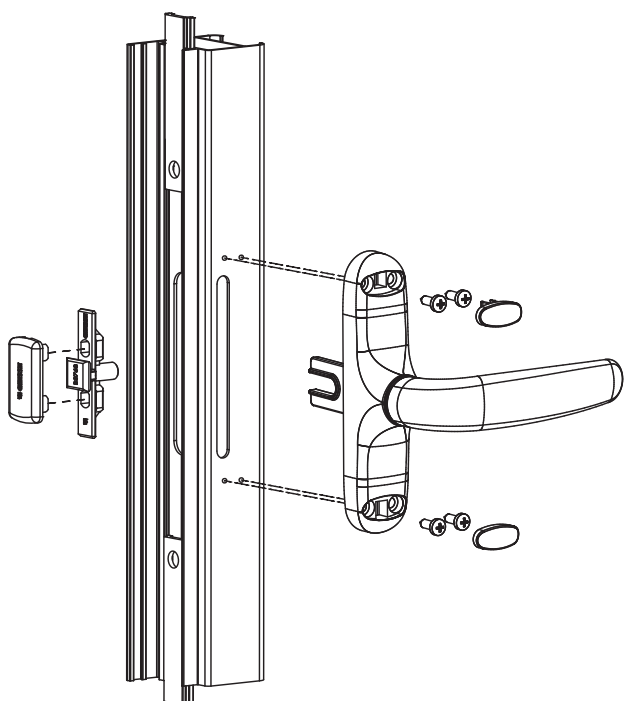

Item code	Description	Type of Opening	L pin	Rod Type	Base Raw	Anodised Elox	Painted	Trend/Gold Brass	Pieces per pack
04091	ROD PULL DEVICE	External - Shutters	40	Euro Groove	X				20
04097001	ROD PULL DEVICE	External - Shutters	26	Erre	X				20
04098001	ROD PULL DEVICE	External - Shutters	9,5	Euro Groove	X				20
04099001	ROD PULL DEVICE	External - Shutters	18,5	Euro Groove	X				20
04104	ROD PULL DEVICE	External - Shutters	19	Euro Groove	X				20
04105	ROD PULL DEVICE	External - Shutters	28	Euro Groove	X				20

CONNECTION PINS



Functions

Zinc plated steel pin to move the mechanism from the cremone to the closing rods.

Online data sheet



Technical features

To be inserted in the telescopic sliders of Unica Apex cremones, in the position shown in the fitting instructions.

Materials

Zinc-nickel plated steel

Example of application with Unica Apex cremone

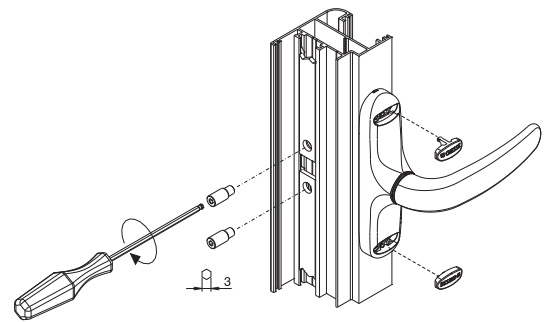
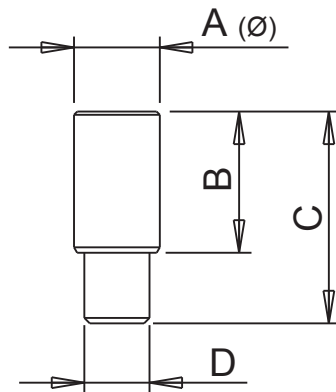
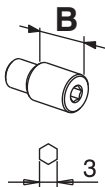
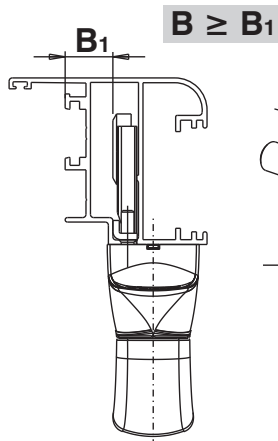
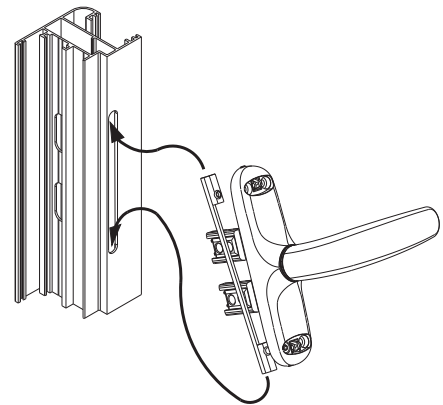
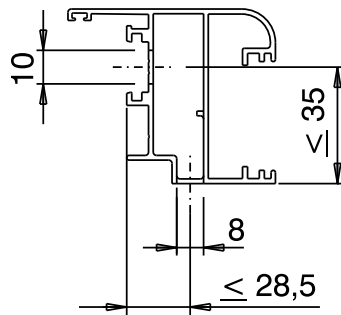
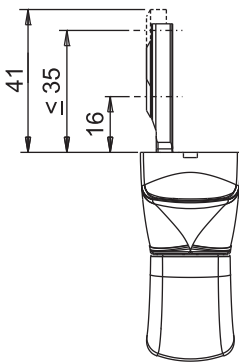

Item code	Description	A (mm)	B (mm)	C (mm)	D	Base Raw	Anodised Elox	Painted	Trend/Gold Brass	Pieces per pack
02251K	CONNECTION PIN	7,9	10	16,5	M6	X				200
02252K	CONNECTION PIN	7,9	13	19,5	M6	X				200
02253K	CONNECTION PIN	7,9	16	22,5	M6	X				200
02254K	CONNECTION PIN	7,9	24	30,5	M6	X				200
02255K	CONNECTION PIN	7,9	20	26,5	M6	X				200

UNICA KEY CREMONE



Functions

Reversible cremone handle with key for operating the Giesse mechanisms.

Online data sheet



Technical Features

The Unica Key cremone has a fixing C/C distance of 104 mm.
 Supplied right-hand pre-assembled it is easily converted into left-hand.
 The pull handle is lockable with a key in both the closed and open position.

Materials

Handle in painted die-cast aluminium.
 Case in paint-finished die-cast zamak.
 Spring in harmonic steel.
 Stainless steel screws and fixing plate.
 Rotor, racks and sliders in die-cast zamak.

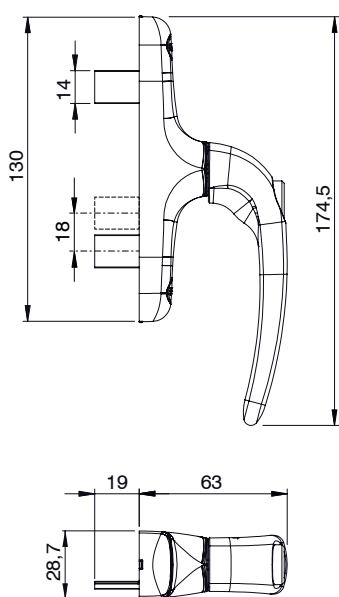

C/C distance machining 104 mm

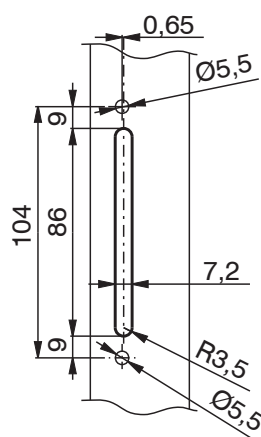

Item code	Description	Type	C/C distances	Operation	Pull handle 0°	Pull handle 90°	Base Raw	Anodised Elox	Painted	Trend/Gold Brass	Pieces per pack
01163N	UNICA KEY CREMONE	Outward Opening Casement - Shutters	104	Two-way	closed	open	X		X		10

UNICA AWAY CREMONE



Functions

Reversible cremone handle, with removable pull handle supplied separately, for operating the Giesse mechanisms. Ideal for hospitals, schools and all other locations in which operation of the casements is not to be left to the discretion of the end user.

Online data sheet



Technical Features

The Unica Away cremone is available both right and left handed and has a fixing C/C distance of 104 mm. The Unica Away Cremone does not have a removable pull handle which is supplied separately. The removable handle can be used in conjunction with all Unica Away Cremones. It is fixed on the snap-mounting cremone by pressing on its hexagon and it stays attached there during operation. The part of the pull handle which mounts to the cremone is designed to engage in such a way that it is always in phase with the mechanism. The design and elongated shape of the handle (172 mm) make it easy to handle in any application.

Materials

Handle in painted die-cast aluminium
 Case in paint-finished die-cast zamak
 Steel spring
 Stainless steel screws and fixing plate.
 Rotor, racks and sliders in die-cast zamak.

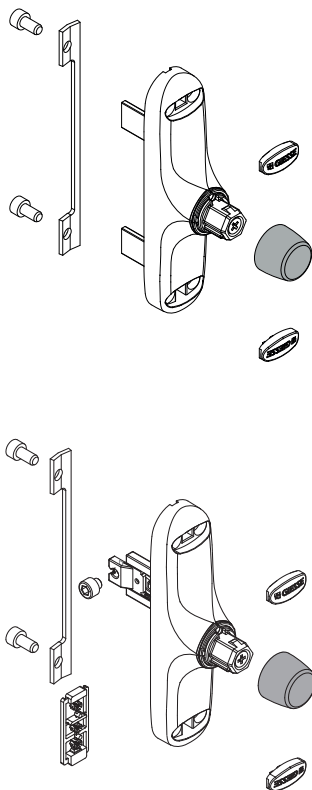

Handle application

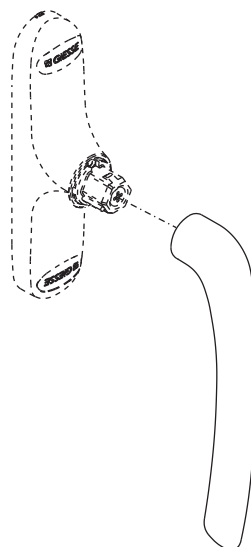

C/C distance machining 104 mm

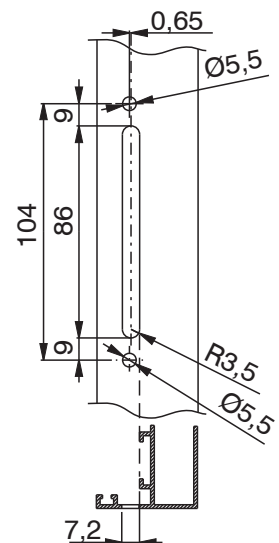

Dimensions art. 01138

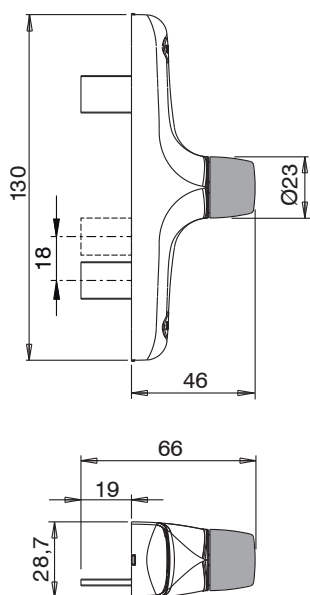

Dimensions art. 01129

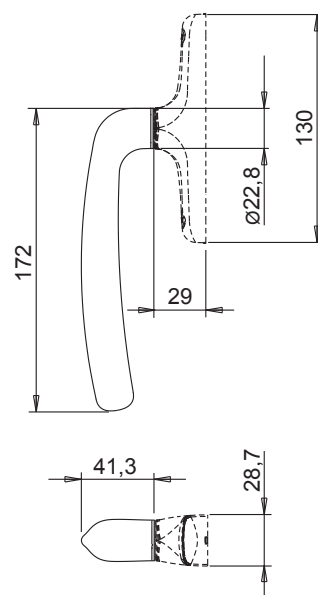

Item code	Description	PROFILE CROSS - SECTION	Type	C/C distances	Operation	Pull handle 0°	Pull handle 90°	Pull handle 180°	Base Raw	Anodised Elox	Painted	Trend/Gold Brass	Pieces per pack
01129	PULL HANDLE FOR UNICA AWAY	-	-	-	-	-	-	-			X		10
01138	UNICA AWAY CREMONE	C001-C002-C003-C004-C005-C006-C007-C008-C009-C010-C012-C013-C014-C015-C016-C017-P001-P002-P004-P005-P006-P007-P008-P009-P010	Inward opening	104	two-way	closed	open				X		10

UNICA CW 2 CREMONE



Functions

Reversible cremone handle for actioning Giesse curtain wall mechanisms.

Online data sheet



Technical Features

The Unica CW2 cremone is available both right and left handed and has a fixing C/C distance of 104 mm. Available with two-way mechanism, with pull handle positioning notch at 0° and 90°. The special form of the pull handle makes it easy to insert the hand, thus allowing the handling of large-size sashes.

Materials

Handle in painted die-cast aluminium
 Case in paint-finished die-cast zamak
 Steel spring
 Stainless steel screws and fixing plate
 Rotor, racks and sliders in die-cast zamak

C/C distance machining 104 mm

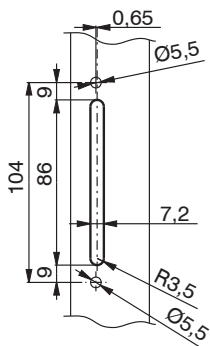

Assembly scheme

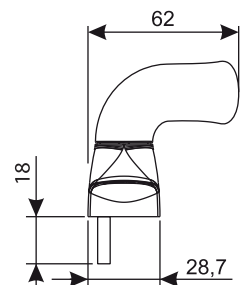
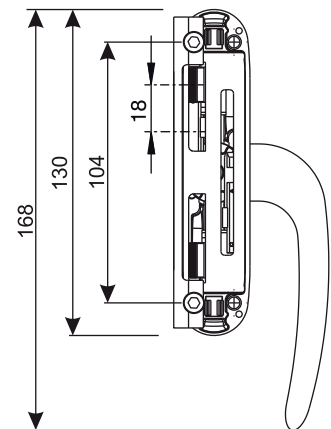
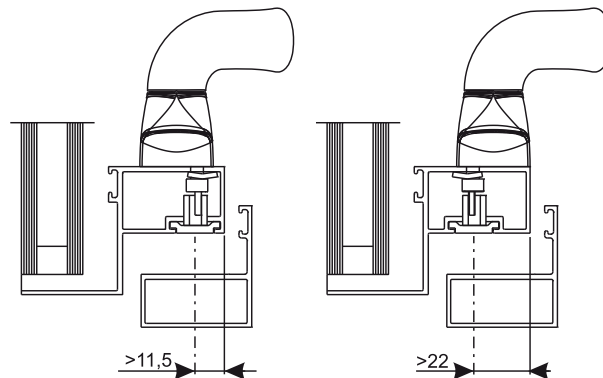

Item code	Description	Hand	Type	C/C distances	Operation	Pull handle 0°	Pull handle 90°	Base Raw	Anodised Elox	Painted	Trend/Gold Brass	Pieces per pack
011701	UNICA OFFSET HANDLE CW2 CREMONE	rx	Curtain wall	104	two-way	closed	open	X		X		5
011702	UNICA OFFSET HANDLE CW2 CREMONE	lx	Curtain wall	104	two-way	closed	open	X		X		5



NOVA CREMONE

Functions

Reversible cremone handle, ideal for outward opening systems and shutters, with handle rotation to 90° and opening/closing positioning notch.

Online data sheet



Technical Features

Available in both one-way and two-way versions. For both versions there is the version with pull handle locking to make the window more secure: on the back of the pull handle there is a button that the end user needs to press to be able to turn the pull handle. Supplied right-hand pre-assembled it has a stroke of 12 mm for the sliders. The NOVA cremone has machining with a C/C distance of 104 mm.

Materials

Handle in die-cast aluminium.
Die-cast Zamak case, gears, racks and sliding parts.
Extruded aluminium body cover.
Fibreglass reinforced polyamide plate.

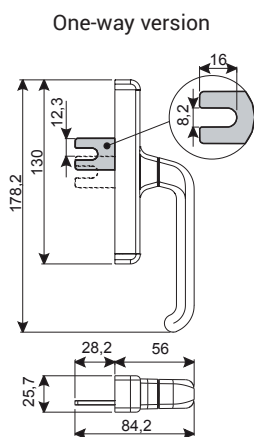

One-way version

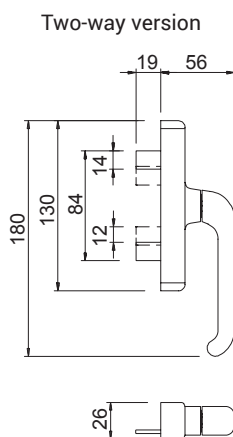

Two-way version

C/C distance machining 104 mm one-way version

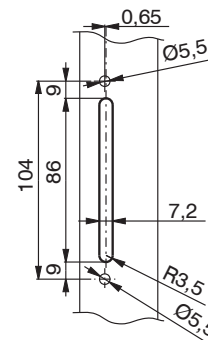

C/C distance machining 108 mm two-way version

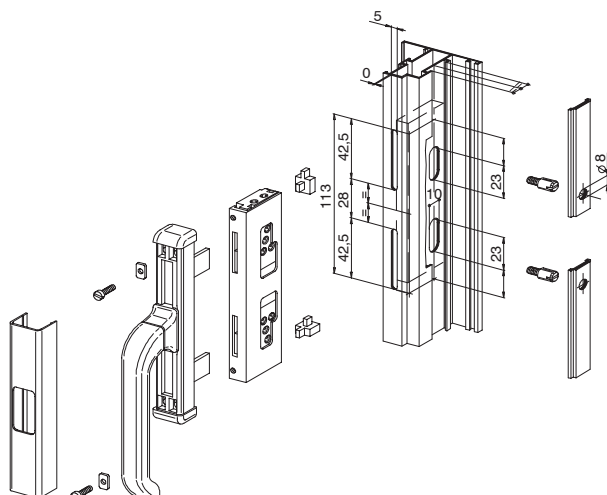

Two-way version machining

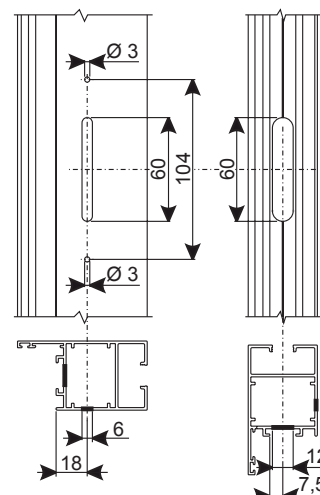

CREMONES

Item code	Description	Type	Functions	C/C distances	Operation	Slider length	Pull handle 0°	Pull handle 90°	Base Raw	Anodised Elox	Painted	Trend/Gold Brass	Pieces per pack
01004	NOVA CREMONE	Outward opening		Figure 1	Two-way	19 mm	Closed	open	X		X		20
01006	NOVA CREMONE - with block	Outward opening	pull handle lock	Figure 1	Two-way	19 mm	Closed	open	X		X		20
01009	NOVA CREMONE with ext. slid.	Outward opening		Figure 1	Two-way	25 mm	Closed	open	X		X		20
01114	NOVA CREMONE SINGLE-SLIDER	Outward opening		Figure 2	One-way	16 mm	Closed	open	X		X		20
01116	NOVA CREMONE W/ SINGLE-SLIDER BLOCK	Outward opening	pull handle lock	Figure 2	One-way	16 mm	Closed	open	X		X		20



SUPERNOVA CREMONE

Functions

Reversible cremone handle, for inward-opening systems with handle rotation to 90° and opening/closing positioning notch.

Online data sheet



Technical Features

As for the EURO Cremones, whose stylish design it incorporates, the use of quality die-cast materials together with the high reliability of the GIESSE painting system gives the SUPERNOVA Cremone high surface quality and strong resistance to external agents.

The SUPERNOVA cremone is supplied right-handed, with a fixing C/C distance of mm. 130 and revives the concept of unification also using the standard EURO machining of 104 mm.

Materials

Handle in die-cast aluminium.
Die-cast Zamak case, gears, racks and sliding parts.

Stainless steel screws

Parts

2 CH screws M4x10

C/C distance machining 104 mm and 130 mm.

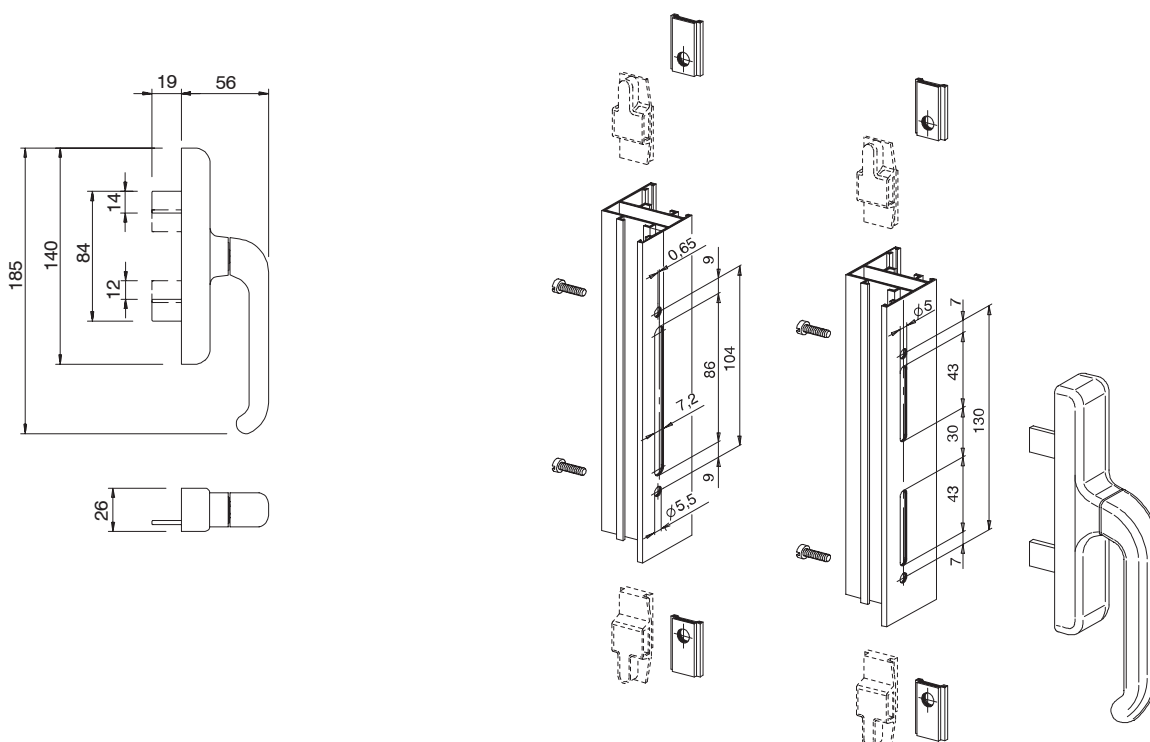

Item code	Description	PROFILE CROSS - SECTION	Base Raw	Anodised Elox	Painted	Trend/Gold Brass	Pieces per pack
01007	SUPERNOVA CREMONE	C001-C002-C003-C004-C005-C006-C007-C008-C009-C010-C012-C013-C014-C015-C016-C017-P001-P002-P004-P005-P006-P007-P008-P009-P010	X		X		20



COUPE' CREMONE

Functions

Reversible cremone handle, with lowered handle and rotation of 120°, designed for outward opening and shutters that, because of the interior dimensions, require a mechanism with a particularly compact size.

Online data sheet



Technical Features

The COUPE' Cremone, supplied right-hand, revives the concept of unification by using the standard EURO 104 mm machining and the 108 mm machining. It is only 38 mm high, with a line that allows you to match it with the EURO, NOVA and SUPERNOVA Cremones.

Materials

Handle in die-cast aluminium
Gears, racks and sliders in die-cast zamak.
Case and plate in reinforced polyamide.
Extruded aluminium body cover.

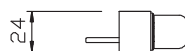
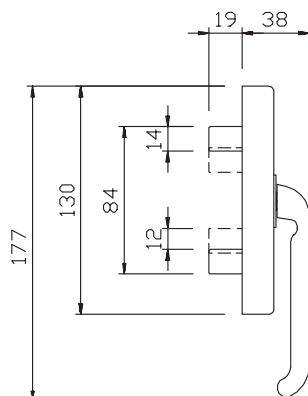
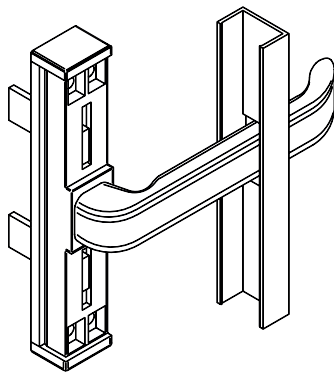

C/C distance machining 104 mm

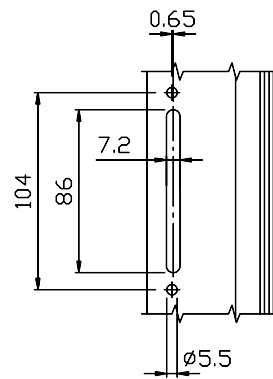

C/C distance machining 108 mm

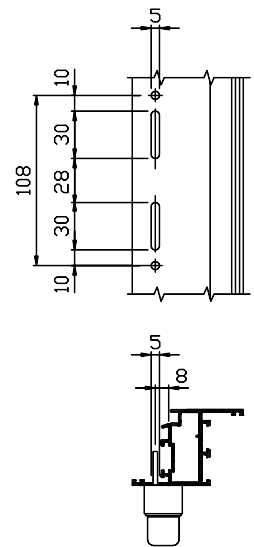

Item code	Description	Note	Base Raw	Anodised Elox	Painted	Trend/Gold Brass	Pieces per pack
01056	COUPE' CREMONE		X		X		20

SHIMS AND STEPS



Functions

Shims and steps in polyamide for mounting Giesse cremones on rounded or stepped profiles

Online data sheet



Technical Features

The shims and steps ensure perfect functionality and hold of the cremones on certain corner-rounded profiles or profiles with a step.

Materials

Polyamide

D1 - Step for Cremone

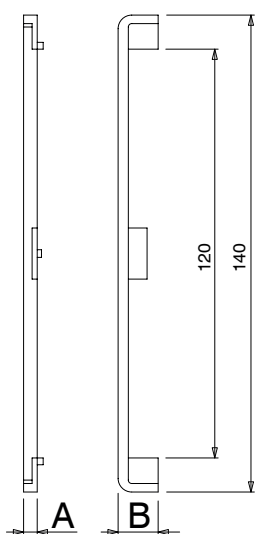

D2 - Shim for cremone (R = radius)

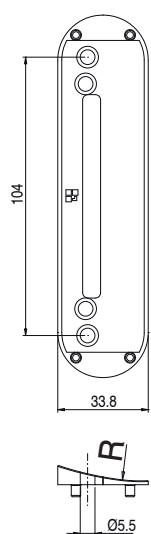

D3 - Shims for incorrect movement safety device

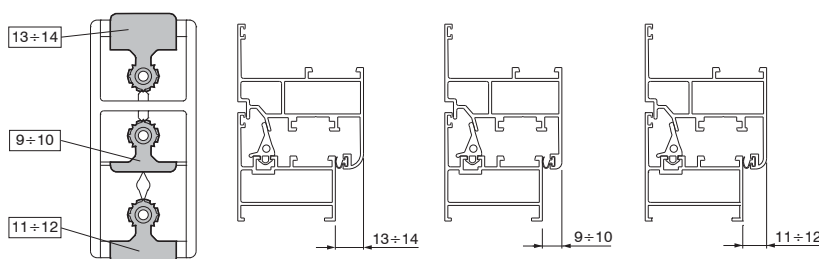

D3 - Mounting shims for incorrect movement safety device

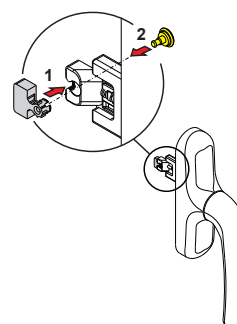

Item code	Description	A (mm)	B (mm)	Radius (mm)	Drawing	Base Raw	Anodised Elox	Painted	Trend/Gold Brass	Pieces per pack
01123	INCORRECT MOVEMENT SAFETY DEVICE SHIM KIT	-	-	-	D3	X				50
01131	SHIM FOR CREMONE	-	-	135	D2	X				100
01132	SHIM FOR CREMONE	-	-	65	D2	X				100
01137	SHIM FOR CREMONE	-	-	120	D2	X				100

STOP BLOCK

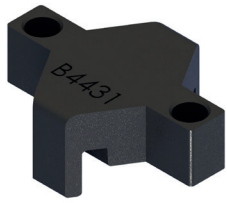

Functions

Component to be inserted in the mechanism of a one-way cremone to lock its rotation at 90°.

Online data sheet



Technical Features

This device must be inserted within the mechanism of one-way cremones if you want to block the stroke of the sliders at 90°.

Materials

Polyamide

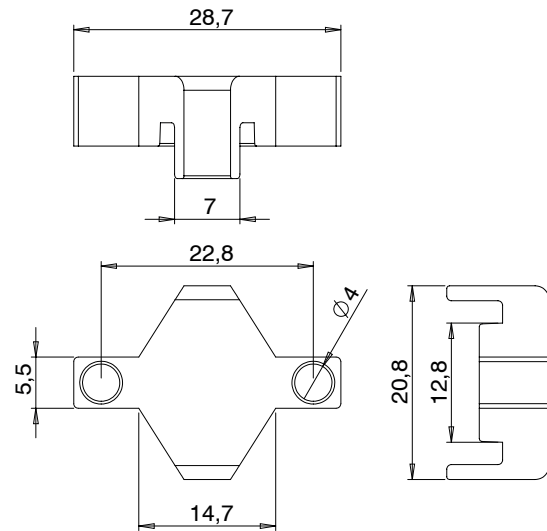

Item code	Description	PROFILE CROSS - SECTION	Base Raw	Anodised Elox	Painted	Trend/Gold Brass	Pieces per pack
02235	90° CREMONE STOP BLOCK	-	X				100

DRIVE ROD COMPONENTS

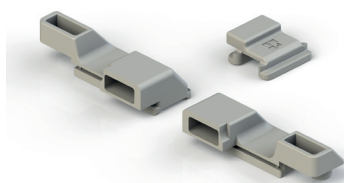

Functions

Polyamide reversible components for the connection between the cremones and the rods of the profile of a central gasket aluminium sash window.

Online data sheet



drawing 1

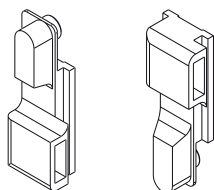

drawing 2

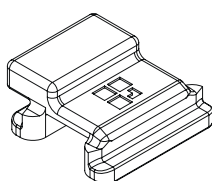

drawing 4

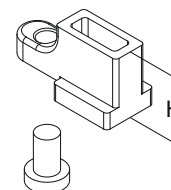

Item code	Description	PROFILE CROSS - SECTION	Material	Colour	Drawing	Ø rod	Base Raw	Anodised Elox	Painted	Trend/Gold Brass	Pieces per pack
02086	CONNECTING BLOCKS	(FOR CURTAIN WALL) H=22,7	Zamak	Grey	drawing 4	6 ÷ 8 mm	X				50
02194	CONNECTING BLOCKS	(FOR CURTAIN WALL) H=12	Zamak	Grey	drawing 4	6 ÷ 8 mm	X				50
02236	CONNECTING BLOCKS	(FOR CURTAIN WALL) H=17,7	Zamak	Grey	drawing 4	6 ÷ 8 mm	X				50
02262	CONNECTING BLOCKS	(FOR CURTAIN WALL) H=14,7	Zamak	Grey	drawing 4	6 ÷ 8 mm	X				50
02385	CONNECTING BLOCKS	C007	Polyamide	Black	drawing 1	8 mm	X				100
02385K	CONNECTING BLOCKS	C007	Polyamide	Grey	drawing 1	8 mm	X				100
02386	CONNECTING BLOCKS	C008	Polyamide	Black	drawing 1	8 mm	X				100
02387	CONNECTING BLOCKS	C001-C002-C003- C004-C005-C006- C009-C010-C012- C013-C014-C015- C016-C017-P001- P002-P004-P005- P006-P007-P008- P009-P010	Polyamide	Black	drawing 1	8 mm	X	X			100
02387K	CONNECTING BLOCKS	C001-C002-C003- C005-C006-C009- C010-C012-C013- C014-C015- C016-C017-P001- P002-P004-P005- P006-P007-P008- P009-P010	Polyamide	Grey	drawing 1	8 mm	X				100
03474	DRIVE ROD COMPONENT	-	Zamak	Black	drawing 2	-	X				20
03474K	DRIVE ROD COMPONENT	C001-C002-C003- C004-C005-C006- C009-C010-C012- C013-C014-C015- C016-C017-P001- P002-P004-P005- P006-P007-P008- P009-P010	Zamak	Grey	drawing 2	-	X				20

CONNECTING KIT

Functions

Components for connecting GIESSE Cremona with the rods of an aluminium window profile.

Online data sheet



Article 02250

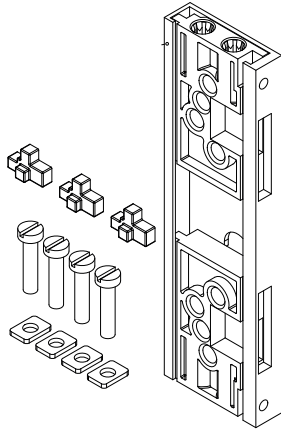

Machining on profile

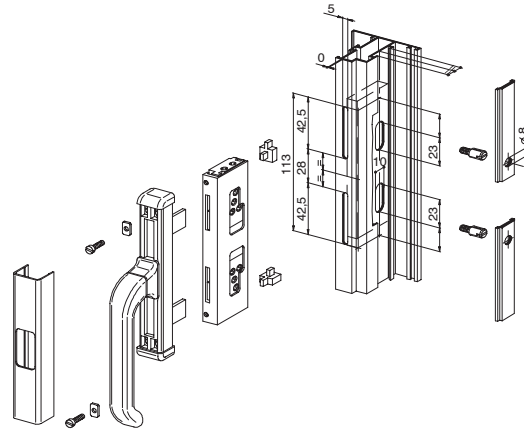

Article 02260

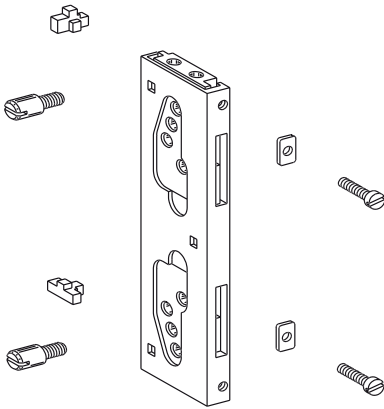

Article 02261

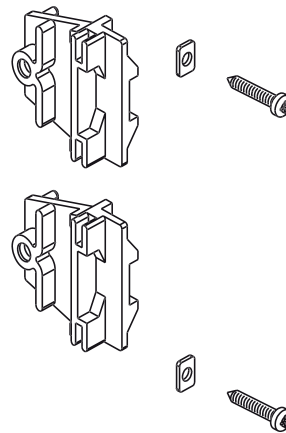

Article 02296

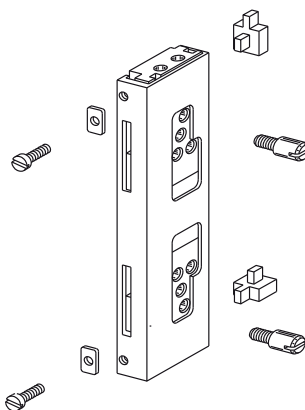

Machining on profile

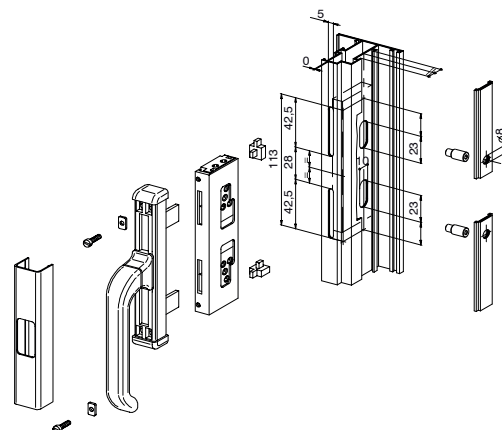

Article 02377

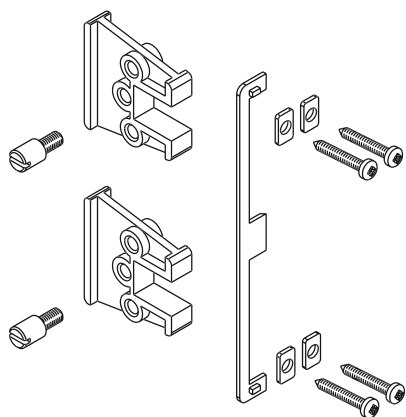

Machining on profile

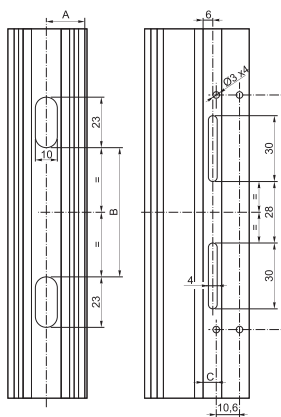

Article 02379

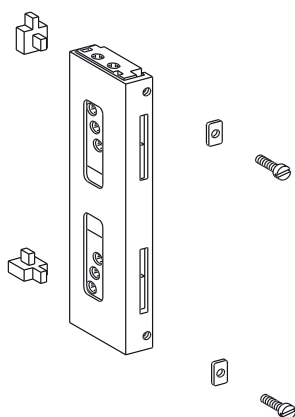

Article 02382N

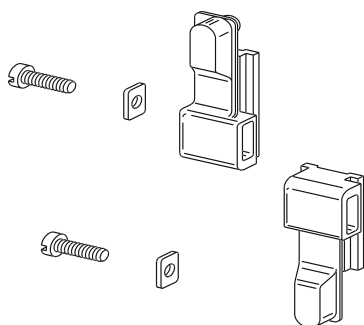

Machining on profile

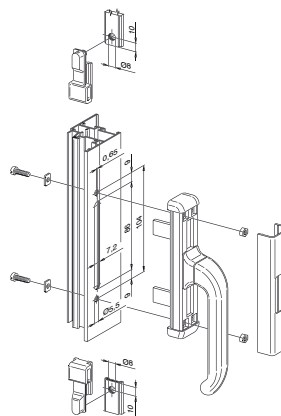

Article 02383

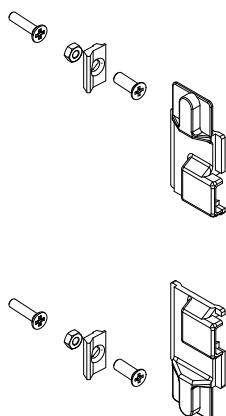

Machining on profile

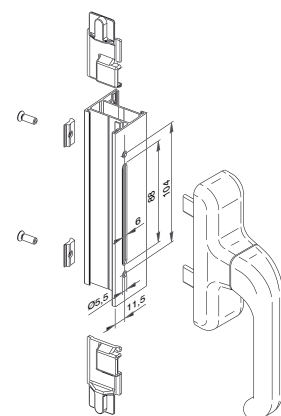

CREMONES

Item code	Description	PROFILE CROSS - SECTION	Base Raw	Anodised Elox	Painted	Trend/Gold Brass	Pieces per pack
02250	NOVA CONNECTION KIT	C001-C002-C003-C006-C008-C014	X				20
02260	NOVA CONNECTION KIT	C001-C002-C015	X				20
02261	NOVA CONNECTION KIT	C001-C002-C015	X				20
02296	NOVA CONNECTION KIT	C001-C002-C013	X				20
02377	NOVA CONNECTION KIT	C008-C010	X				20
02379	NOVA CONNECTION KIT	C001-C002	X				20
02382N	NOVA CONNECTION KIT	C001-C002-C003-C006-C010-C013-C014-C015	X				20
02383	EURO CONNECTION KIT	-	X				20

CONNECTION PINS



Functions

Zinc plated steel pin to move the mechanism from the cremone to the closing rods.

Online data sheet



Technical Features

To be inserted in the guide blocks of Article 02250 in the position shown on the instruction sheet.

Materials

Zinc-nickel plated steel

Example of application with Nova connection kit

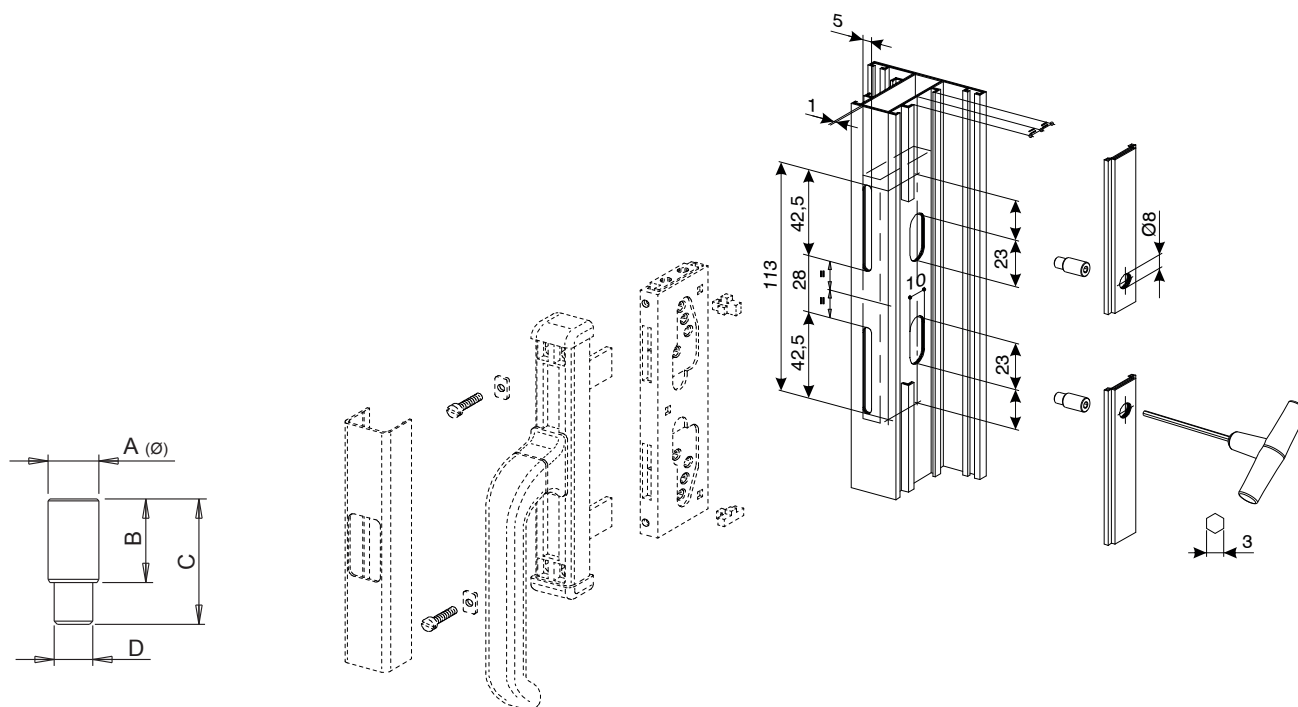

Item code	Description	A (mm)	B (mm)	C (mm)	D	Base Raw	Anodised Elox	Painted	Trend/Gold Brass	Pieces per pack
02251K	CONNECTION PIN	7,9	10	16,5	M6	X				200
02252K	CONNECTION PIN	7,9	13	19,5	M6	X				200
02253K	CONNECTION PIN	7,9	16	22,5	M6	X				200
02254K	CONNECTION PIN	7,9	24	30,5	M6	X				200
02255K	CONNECTION PIN	7,9	20	26,5	M6	X				200

BLANK CREMONE ASSEMBLY

Functions

Specific equipment for assembling the case and handle of the GIESSE Cremonese purchased blank.

Online data sheet

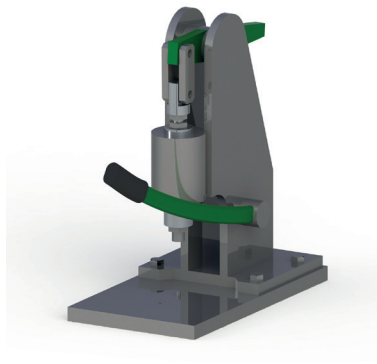

Technical Features

To make it possible to assemble cremonese after final painting, GIESSE has developed specific equipment: the manual lever press and pallets to support the cremonese pull handles.

Using an appropriate pallet, for Prima, Asia, Euro or Unica, accomplishes the delicate phase of driving in the rotor without damaging the case and handle. The press punch can be adjusted to have an appropriate pressure on the rotor depending on the cremonese to be assembled.

Manual lever press

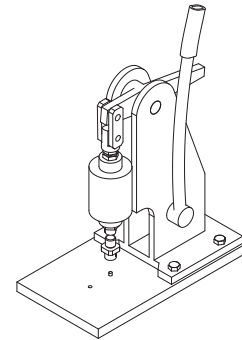

Support cover for painting

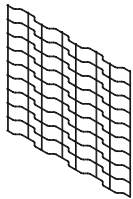

Pallet for PRIMA cremonese

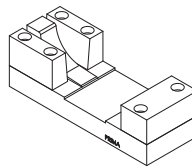

Pallet for EURO cremonese

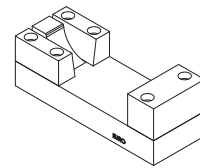

Pallet for UNICA cremonese

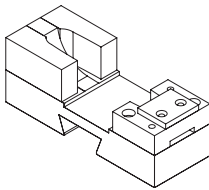

UNICA CW2 lh cremonese pallet

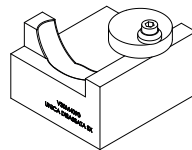

Item code	Description	For articles	Base Raw	Anodised Elox	Painted	Trend/Gold Brass	Pieces per pack
04085	SUPPORT COVER FOR PAINTING	-	X				10
07000	MANUAL LEVER PRESS	07002 - 07003 - 07005	X				1
07002	PRIMA CREMONE PALLET	01024U - 01038 - 01039	X				1
07003	EURO CREMONE PALLET	01090K - 01000U - 01037 - 01094	X				1
07005	UNICA CREMONE PALLET	01150N - 01157N - 01159N - 01155N - 01164N - 01165N - 01166N - 01173N	X				1
07006	UNICA CW2 LH CREMONE PALLET	011702	X				1
07008	ASIA CREMONE PALLET	01064 - 01076 - 01083 - 01084	X				1
07009	PRIMA KEY CREMONE PALLET	01191 - 01192 - 01193 - 01194 - 01195	X				1
07012	PALLET FOR ASIA OUTWARD CREMONE	01077 - 01063	X				1



ASIA WINDOW HANDLE

Functions

Reversible window handle for operating the GIESSE Sash and Tilt-and-Turn Window closing systems via the M90 and M180 mechanisms.

Online data sheet



Technical Features

The handle is made of die-cast aluminium and blends in seamlessly with the Asia cremone line.

The handle is equipped with a positioner to stop rotation at 90° and 180° and has a square pin, 7 mm cross section, for the transmission of the movement.

Materials

Handle in die-cast aluminium

Rotor in zinc plated zamak

Aluminium cover

Sub-rosette in plastic resin

Square spindle and screws in zinc plated steel

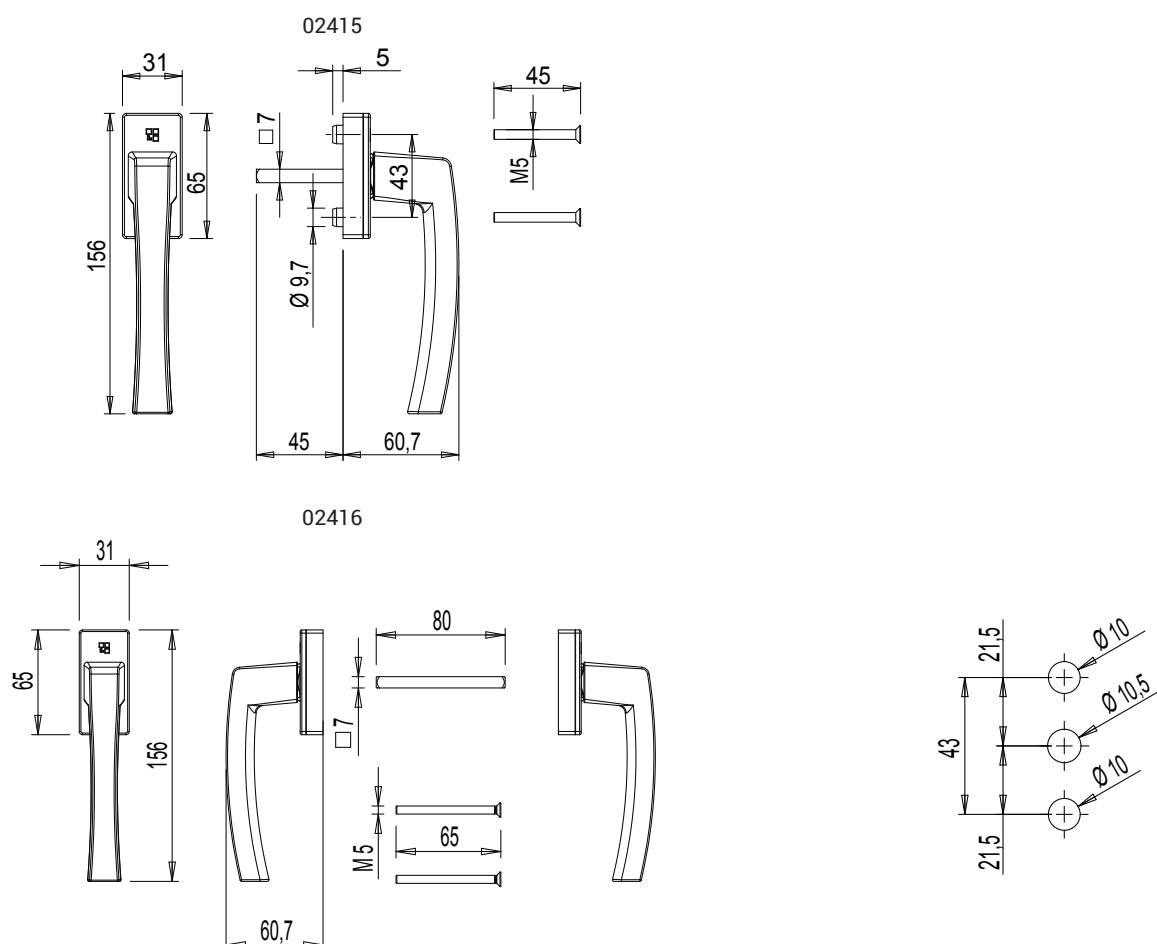

Item code	Description	Version	Square spindle L (mm)	Case anti-rotation turrets	PROFILE CROSS - SECTION	Pull handle 0°	Pull handle 90°	Pull handle 180°	Base Raw	Anodised Elox	Painted	Trend/Gold Brass	Pieces per pack
02415	ASIA WINDOW HANDLE	Single	45	Yes	C001-C002-C003-C004-C005-C006-C007-C009-C010-C011-C012-C013-C014-C015-C016-C017-P001-P002-P003-P004-P005-P006-P007-P008-P009-P010	closed	open	bot-tom-hung windows	X		X		10
02416	ASIA WINDOW HANDLE	Double	26-46	No	-	closed	open	-	X		X		5

PRIMA PLUS WINDOW HANDLE



Functions

Reversible window handle for operating the GIESSE Sash and Tilt-and-Turn Window closing systems via the M90 and M180 mechanisms.

Online data sheet



Technical Features

The handle is made of die-cast aluminium and blends in seamlessly with the Prima cremone line.

It is equipped with a positioner for stopping the rotation at 90° and 180° and has a square pin, for the transmission of the movement, with a cross section of 7 mm and a length of 45 mm.

Available in both single and double versions.

Materials

Handle in die-cast aluminium

Rotor in zinc plated zamak

Die-cast aluminium cover

Sub-rosette in plastic resin

Square spindle and screws in zinc plated steel

Art. 02476

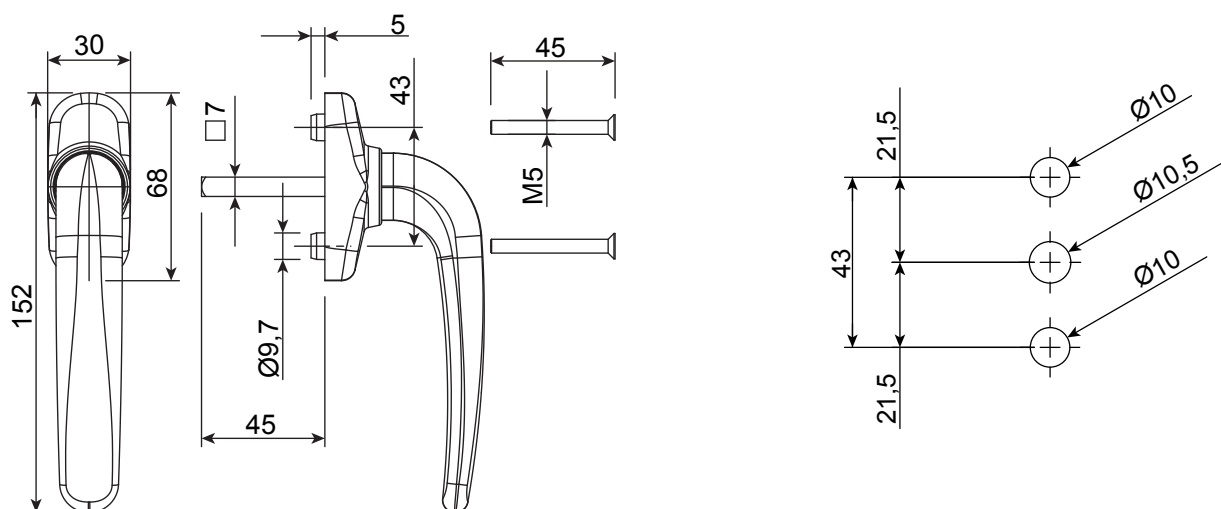

Art. 02762

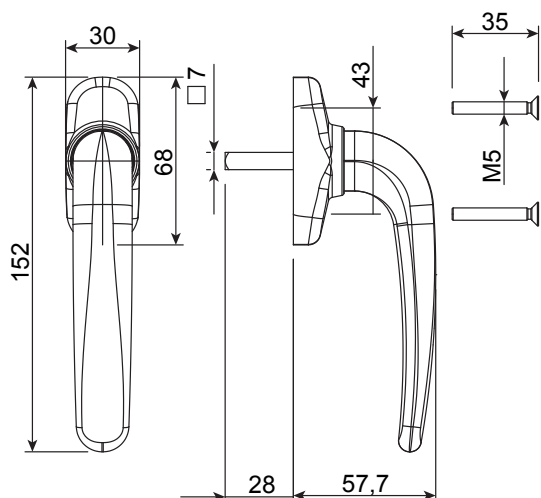

Art. 02763

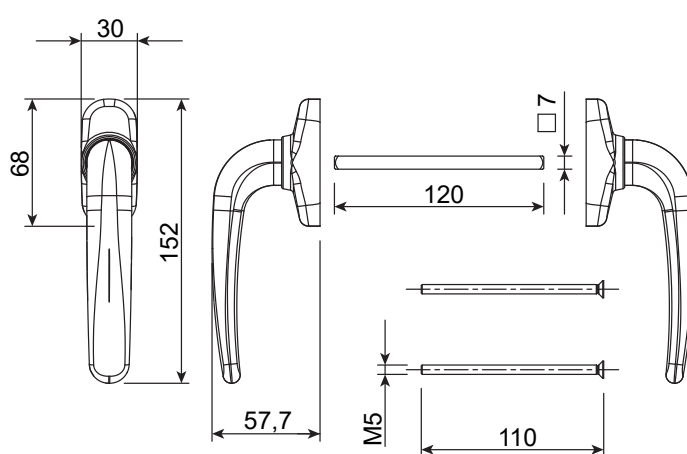

Item code	Description	Version	Square spindle L (mm)	Case anti-rotation turrets	PROFILE CROSS - SECTION	Pull handle 0°	Pull handle 90°	Pull handle 180°	Base Raw	Anodised Elox	Painted	Trend/Gold Brass	Pieces per pack
02476	PRIMA PLUS WINDOW HANDLE	Single	45	Yes	C001	closed	open	bot-tom-hung windows	X		X	X	10
02762	PRIMA PLUS WINDOW HANDLE	Single	27	No	C001-C002-C003-C004-C005-C006-C007-C009-C010-C011-C012-C013-C014-C015-C016-C017-P001-P002-P003-P004-P005-P006-P007-P008-P009-P010	closed	open	bot-tom-hung windows	X		X	X	5
02763	PRIMA PLUS WINDOW HANDLE	Double	26-46	No	-	closed	open	-	X		X	X	5

KORA WINDOW HANDLE



Functions

Reversible window handle for operating GIESSE Side-hung, Tilt-and-Turn, and Tilt-and-Turn with Micro-ventilation fastening mechanisms, via M90 and M180 mechanisms.

Online data sheet



Technical Features

The handle is equipped with a positioner to stop rotation at 90° and 180° and has a square pin, 7 mm cross section and 40 mm length, for transmission of the movement.

Materials

Zamak handle
Square pin, screws and grub screw in zinc plated steel

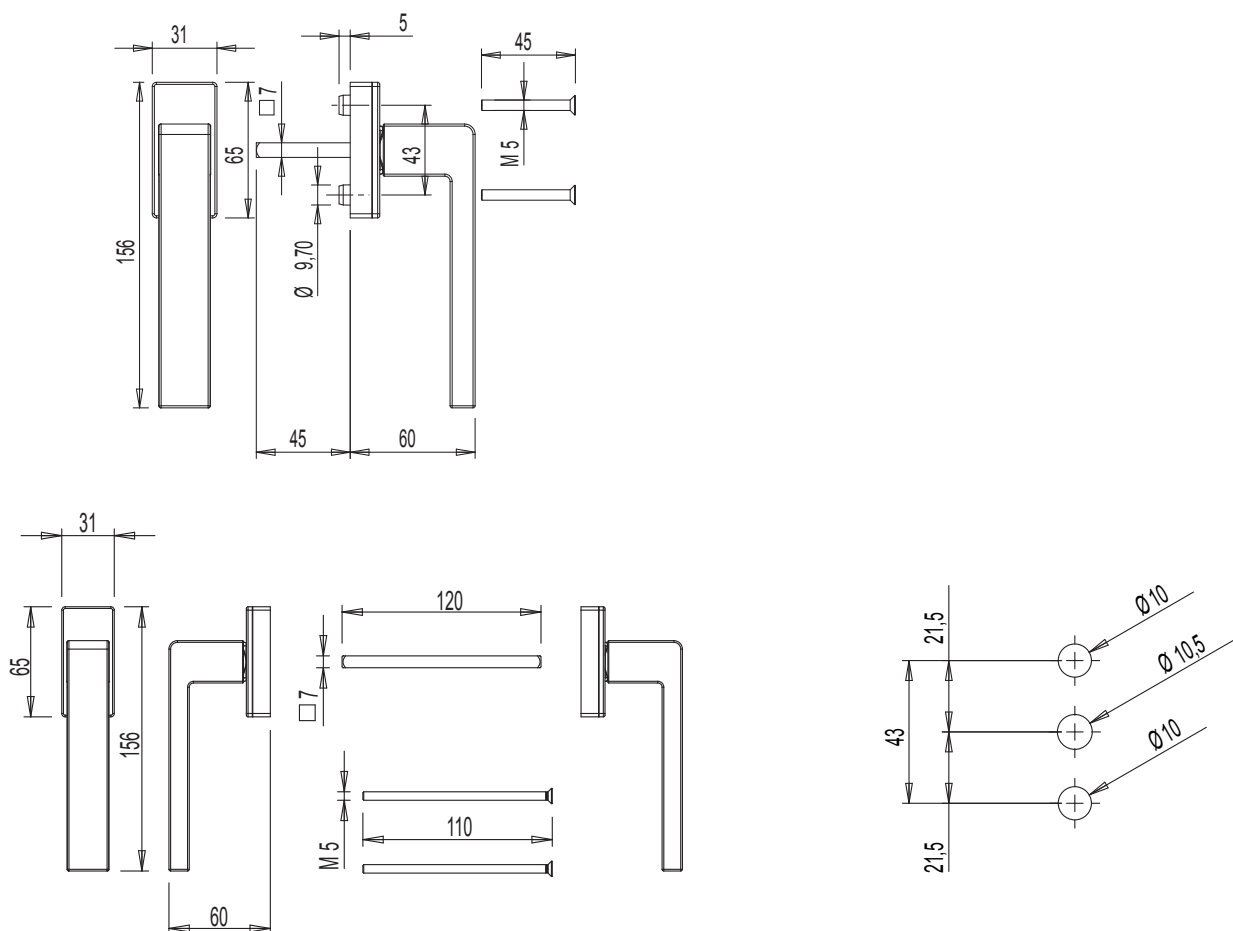

Item code	Description	Version	Square spindle L (mm)	Case anti-rotation turrets	PROFILE CROSS - SECTION	Pull handle 0°	Pull handle 90°	Pull handle 180°	Base Raw	Anodised Elox	Painted	Trend/Gold Brass	Pieces per pack
00997	KORA WINDOW HANDLE	Single	45	Yes	C001-C002-C007-C017-P002-P006-P007	closed	open	bottom-hung windows	X		X		10
00998	KORA WINDOW HANDLE	Double	26-46	No	-	closed	open	-	X		X		5



KORA OFFSET WINDOW HANDLE

Functions

Right-hand or left-hand window handle for the use of GIESSE Sash, Tilt-and-Turn, Sliding and Top-Hung internal movement fastening mechanisms.

Online data sheet



Technical Features

The offset Kora window handles are sold in right-hand or left-hand versions and are used in conjunction with Giesse internal mechanisms.

They are equipped with a positioner for stopping the rotation at 90° and 180° and configure the transmission of the movement of a non-removable 7 mm square pin.

The length of the pin can be varied on request. The c/c fixing distance for the window handles is 43 mm (standard).

The case for the offset Kora window handles with a large plate features 2 additional holes in case you want to use 2 self-threading screws (not supplied) to strengthen the window handle fixing on the sash profile.

Materials

Handle in aluminium

Square spindle and screws in zinc plated steel

0099611

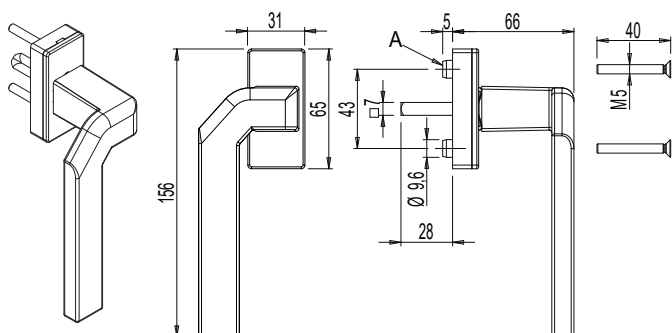

0099621

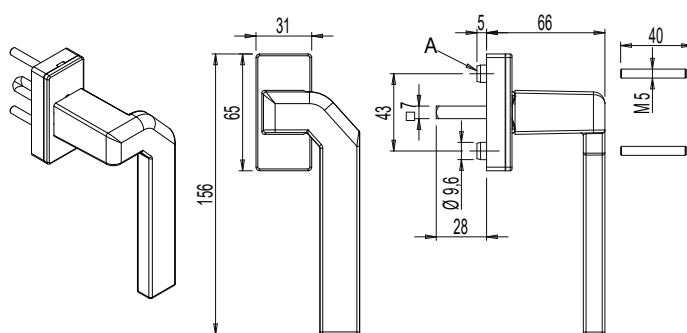

0304911

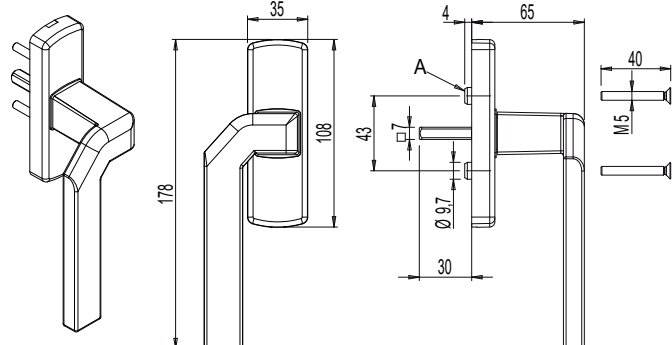

0304921

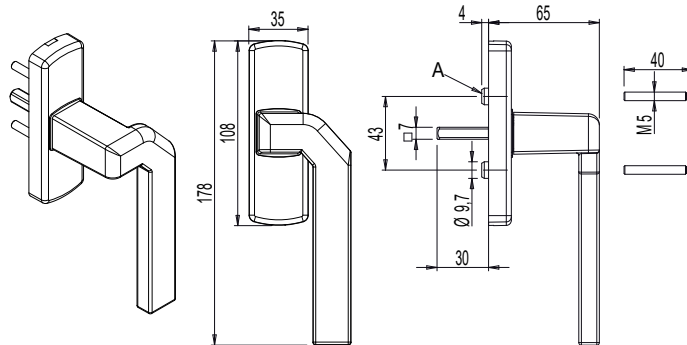

WINDOW HANDLES

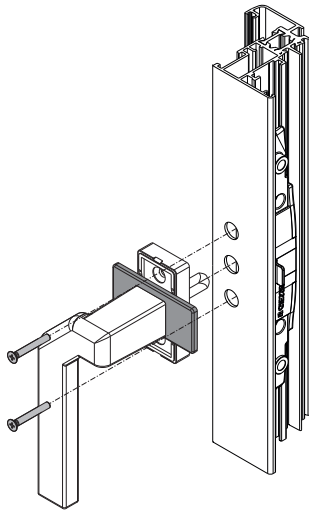

Machining

A = Case anti-rotation turrets

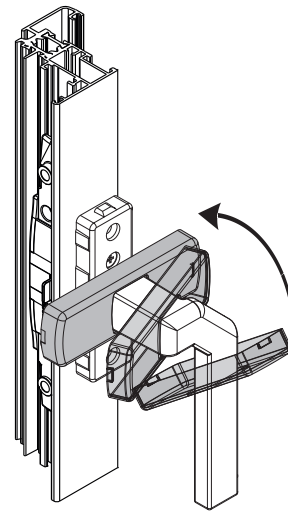
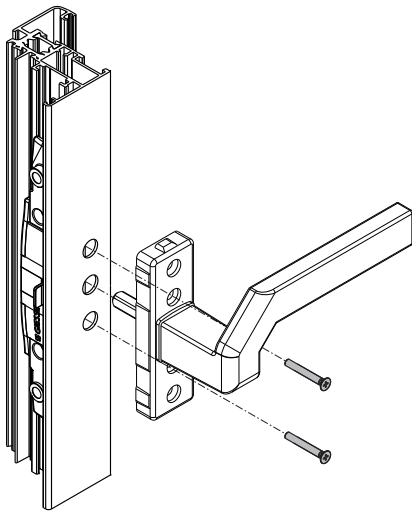
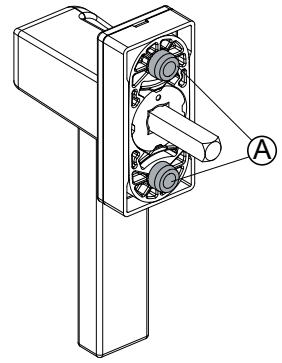
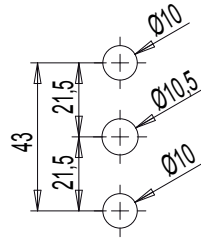

00992

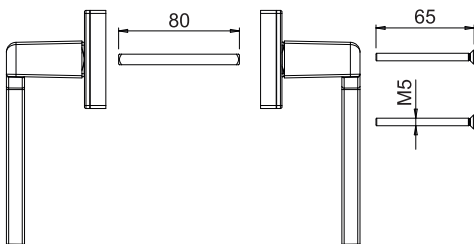
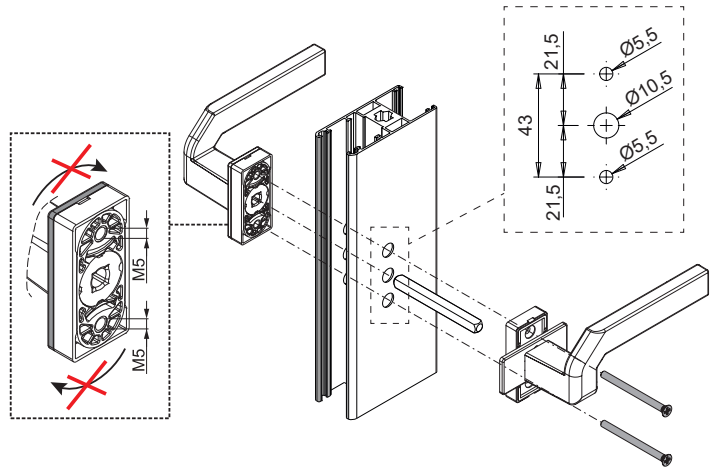
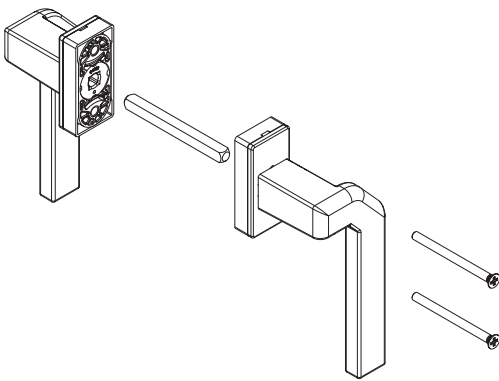

Item code	Description	Version	Case anti-rotation turrets (A)	PROFILE CROSS - SECTION	Base Raw	Anodised Elox	Painted	Trend/Gold Brass	Pieces per pack
00992	KORA OFFSET WINDOW HANDLE	Pair	No	C001-C002-C003-C004-C005-C006-C007-C009-C010-C011-C012-C013-C014-C015-C016-C017-P001-P002-P003-P004-P005-P006-P007-P008-P009-P010	X		X	X	5
0099611	KORA OFFSET WINDOW HANDLE	Right	Yes	C001-C002-C003-C004-C005-C006-C010-C012-C013-C014-C015-C016-C017-P001-P002-P003-P005-P006-P007-P008-P009-P010	X		X	X	5
0099621	KORA OFFSET WINDOW HANDLE	Left	Yes	C001-C002-C003-C004-C005-C006-C010-C012-C013-C014-C015-C016-C017-P001-P002-P003-P005-P006-P007-P008-P009-P010	X		X	X	5
0304911	OFFSET KORA WINDOW HANDLE WITH LARGE PLATE	Right	Yes	C001-C002-C003-C004-C005-C006-C010-C012-C013-C014-C015-C016-C017-P001-P002-P004-P005-P006-P007-P008-P009-P010	X		X	X	5
0304921	OFFSET KORA WINDOW HANDLE WITH LARGE PLATE	Left	Yes	C001-C002-C003-C004-C005-C006-C010-C012-C013-C014-C015-C016-C017-P001-P002-P004-P005-P006-P007-P008-P009-P010	X		X	X	5



GAIA WINDOW HANDLE

Functions

Reversible window handle for operating GIESSE Side-hung, Tilt-and-Turn, and Tilt-and-Turn with Micro-ventilation fastening mechanisms, via M90 and M180 mechanisms.

Online data sheet



Technical Features

The Gaia window handle is supplied without the pin and fixing screws, which must be ordered separately depending on the size of the profile (see table). It is equipped with a positioner for stopping the 90° and 180° rotation.

Materials

Handle and case in aluminium

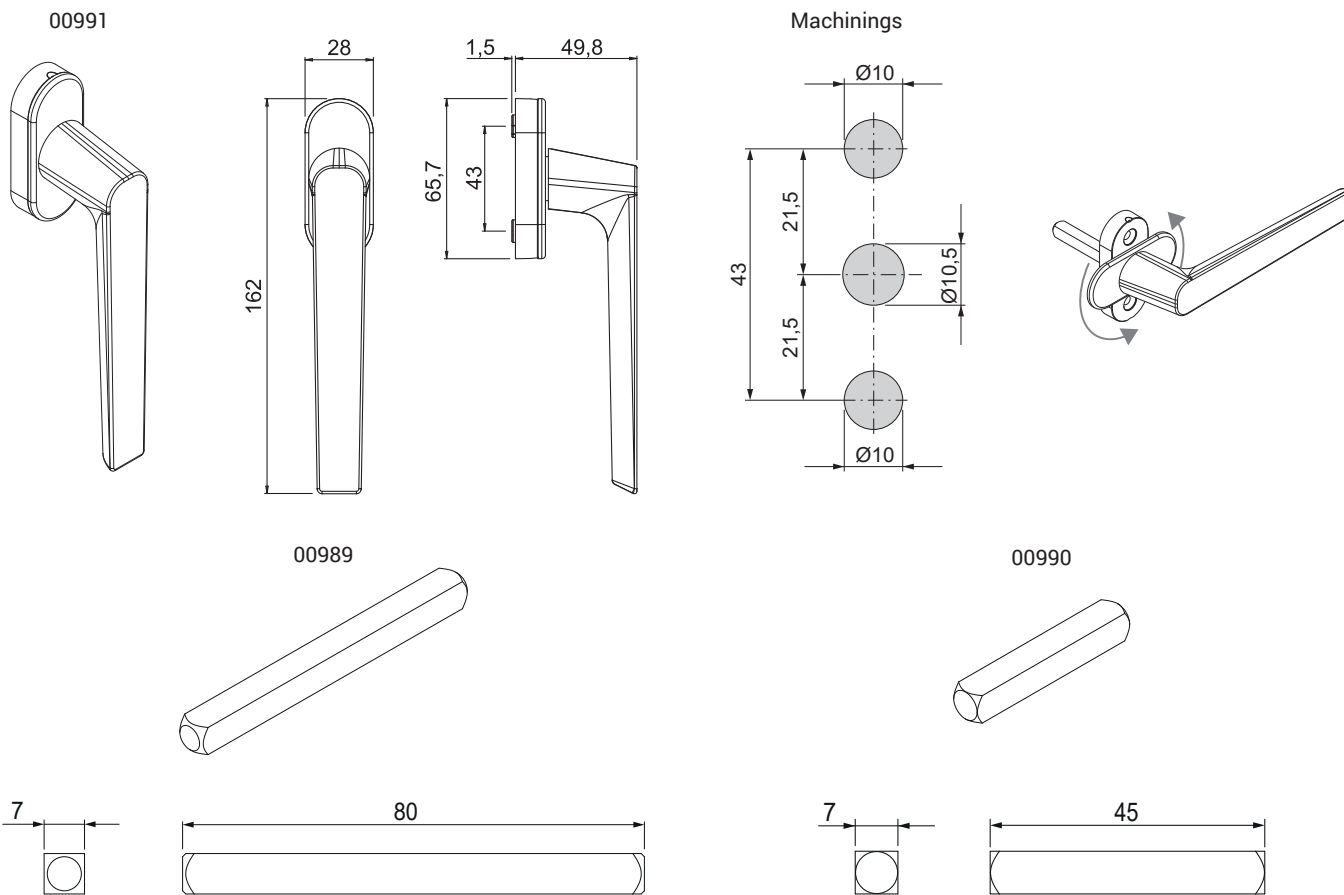

Item code	Description	Version	Case anti-rotation turrets	Base Raw	Anodised Elox	Painted	Trend/Gold Brass	Pieces per pack
00991	GAIA WINDOW HANDLE	Single	Yes			X		40

Item code	Description	Square spindle L (mm)	Base Raw	Anodised Elox	Painted	Trend/Gold Brass	Pieces per pack
00989	WINDOW HANDLE SQUARE PIN	80	X				300
00990	WINDOW HANDLE SQUARE PIN	45	X				500



GAIA OFFSET WINDOW HANDLE

Functions

Right-hand or left-hand window handle for the use of GIESSE Sash, Tilt-and-Turn, Sliding and Top-Hung internal movement fastening mechanisms.

Online data sheet



Technical Features

The Gaia window handle is supplied without the pin and fixing screws, which must be ordered separately depending on the size of the profile (see table). It is equipped with a positioner for stopping the 90° and 180° rotation.

Materials

Handle and case in aluminium

009881

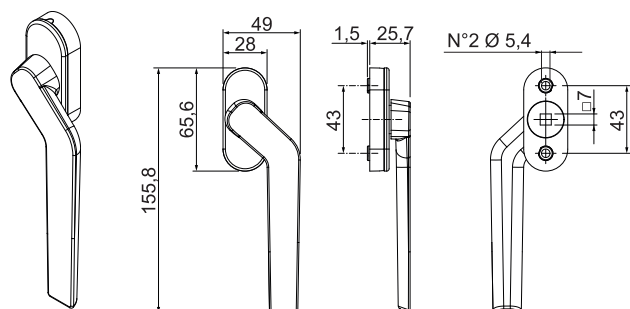

009882

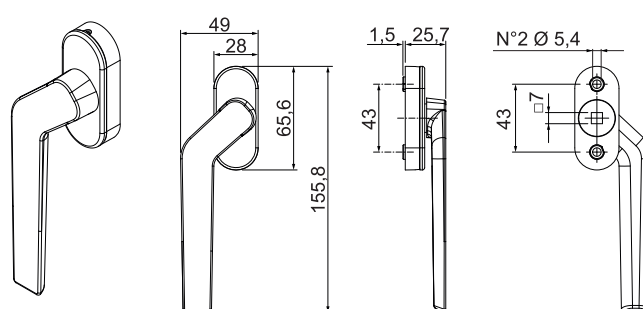

Machinings

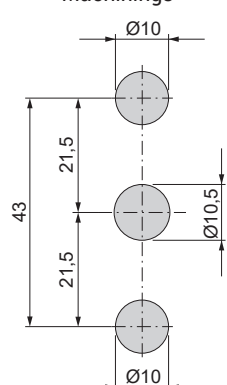

00989

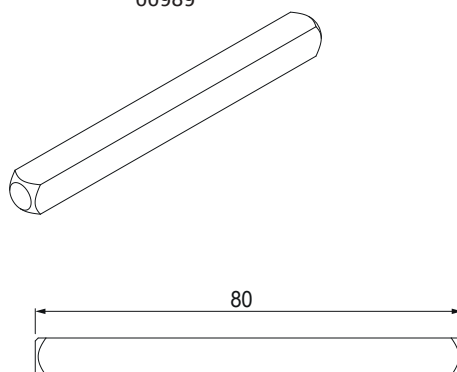

00990

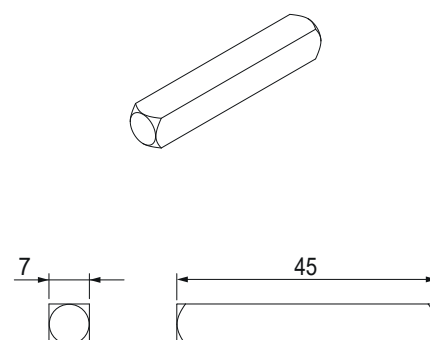

Item code	Description	Version	Case anti-rotation turrets	Base Raw	Anodised Elox	Painted	Trend/Gold Brass	Pieces per pack
009881	GAIA OFFSET WINDOW HANDLE	Right	Yes			X		40
009882	GAIA OFFSET WINDOW HANDLE	Left	Yes			X		40

Item code	Description	Square spindle L (mm)	Base Raw	Anodised Elox	Painted	Trend/Gold Brass	Pieces per pack
00989	WINDOW HANDLE SQUARE PIN	80	X				300
00990	WINDOW HANDLE SQUARE PIN	45	X				500

BAS WINDOW HANDLE



Functions

The Bas window handle is ideal for operating mechanisms with rotors designed to be actuated by a 7 mm square pin, such as the Champion Plus multilock or the M90 or M180 internal mechanisms.

Online data sheet



Technical Features

The Bas window handle is naturally applied on outward opening casements that require a particularly short width of the plate of the window handle. As a matter of fact, on this product the plate is just 17.5 mm. The square pin with a length of 70 mm enables fitting the product on outward opening casements where the mechanism is far away from the window handle (on the inside). The c/c distance for fixing the product to the hardware is 43 mm, used on most hardware with a rotor for 7 mm square pins.

Materials

Handle of aluminium, plate of zamak
 Trip spring of spring steel
 Retaining washer and square pin of zinc plated steel
 Polyamide caps

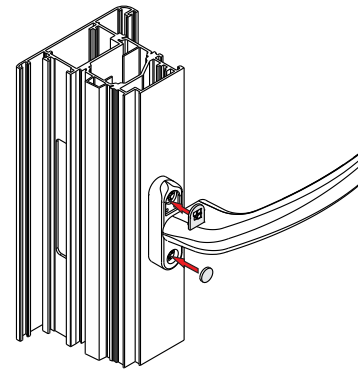
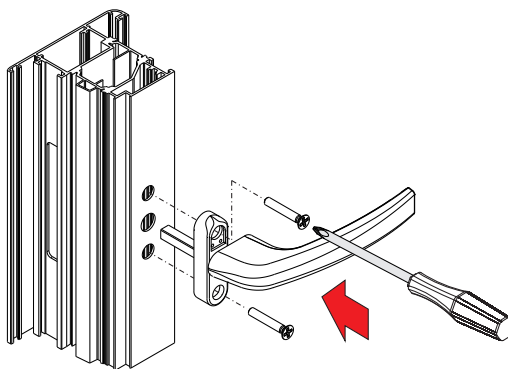
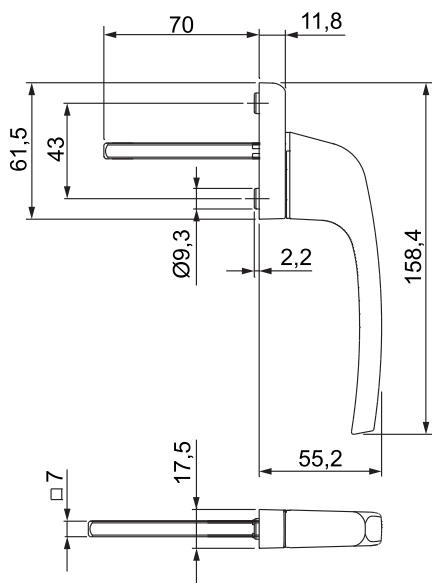

Item code	Description	PROFILE CROSS - SECTION	Note	Base Raw	Anodised Elox	Painted	Trend/Gold Brass	Pieces per pack
02491	BAS WINDOW HANDLE	C001-C016-P002				X		5



COMPA WINDOW HANDLE

Functions

The Compa window handle is ideal for operating mechanisms with rotors designed to be actuated by a 7 mm square pin, such as the Champion Plus multilock.

Online data sheet



Technical Features

The window handle is ergonomic and easy to grip for handy operation. The product's lowered handle means that its application is ideal for folding doors, sliding casements and outward opening. The c/c distance for fixing the product to the hardware is 43 mm, used on most hardware with a rotor for 7 mm square pins.

Materials

Handle, washer and pin support of zamak
 Spring of spring steel
 Square pin and pin of zinc plated steel
 Polyamide caps

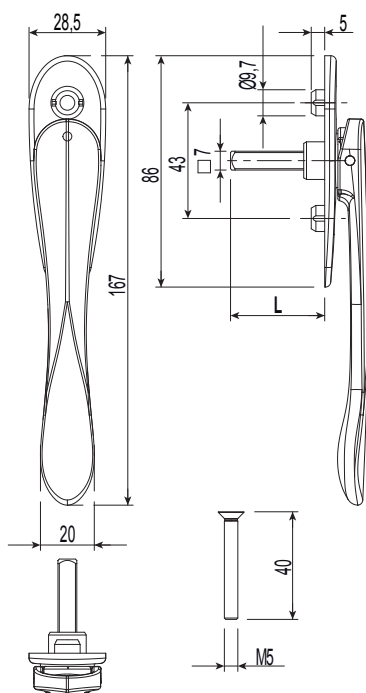

Item code	Description	L (pin length)	Base Raw	Anodised Elox	Painted	Trend/Gold Brass	Pieces per pack
0249201	COMPA WINDOW HANDLE	35 mm	X		X		5
02494	COMPA WINDOW HANDLE	50 mm	X		X		5
02500	COMPA WINDOW HANDLE	70 mm	X		X		5

TWO-WAY INTERNAL MECHANISMS



Functions

Two-way mechanism, operated by a window handle, to be inserted in the tubular section of the profile.

Online data sheet



Technical Features

The two-way mechanisms are reversible and designed to be combined with all the window handles made by GIESSE, both in aluminium and brass (with 7 mm square spindle).

The shim, when supplied, is to be placed inside the tubular section of the profile, between the mechanism and the window handle, to enable perfect alignment of the parts.

Connected to the rod, it allows opening/closing inward-opening, pivoting or awning casements.

Materials

Case, cover and racks in die-cast zamak
Main and secondary gear in die-cast zamak
Shims in black polyamide
Stainless steel screws

Type A

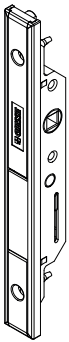

Type A: dimensions

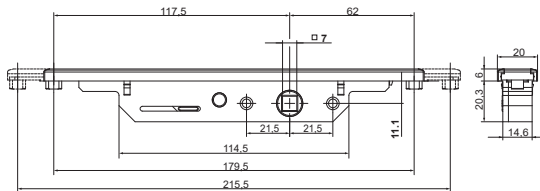

Type A: machining

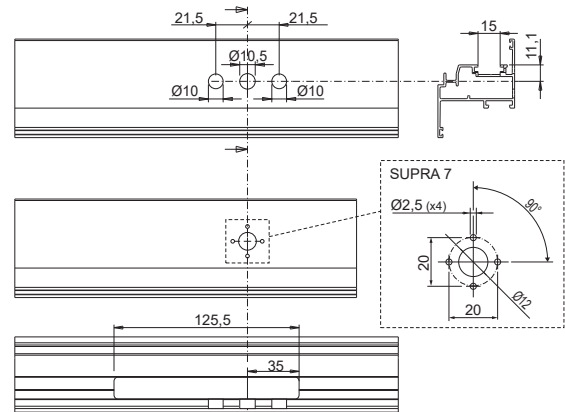

Type B

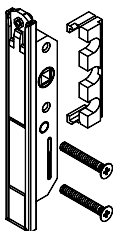

Type B: dimensions

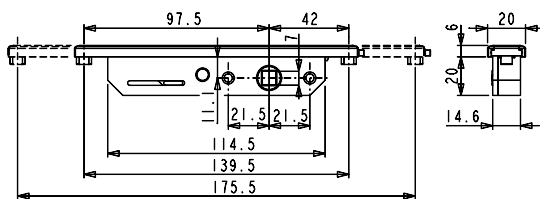

Type B: machining

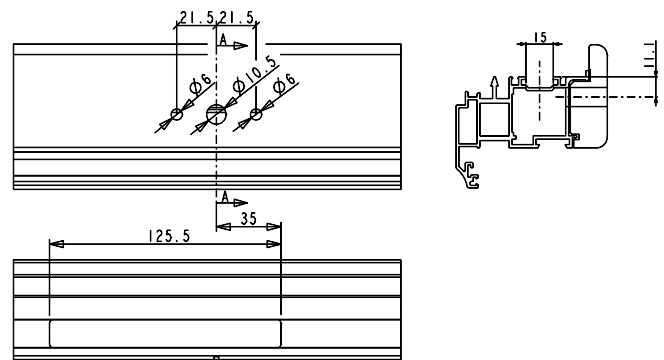

Type C

Type C: dimensions

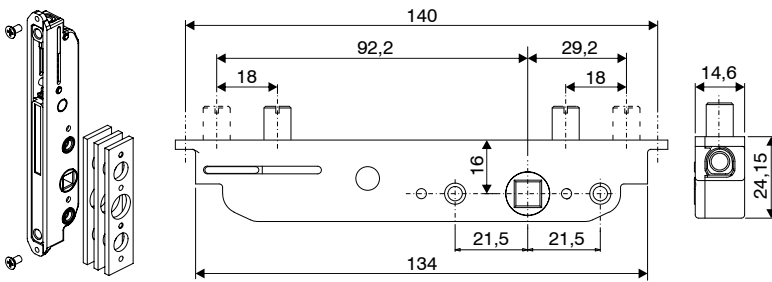

Type C: machining

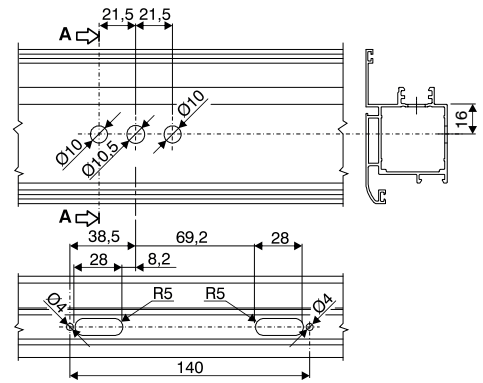

Type D

Type D: dimensions

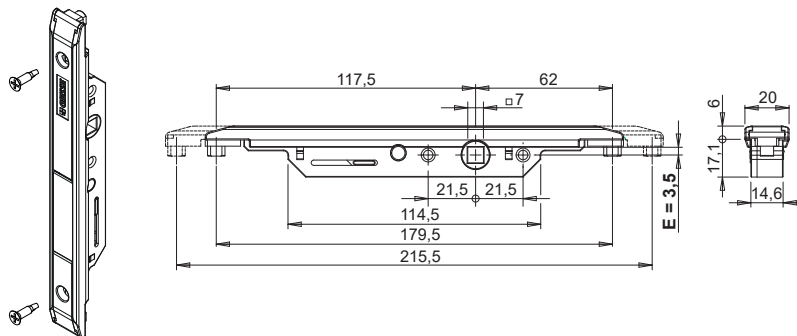

Type D: machining

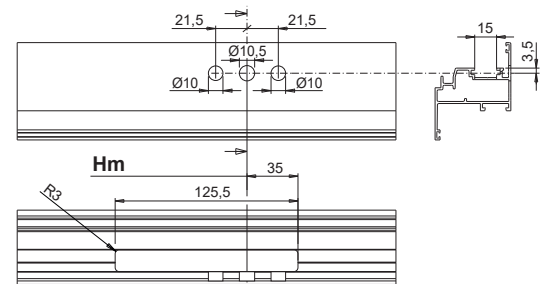

Type E

Assembly with movement 0102001

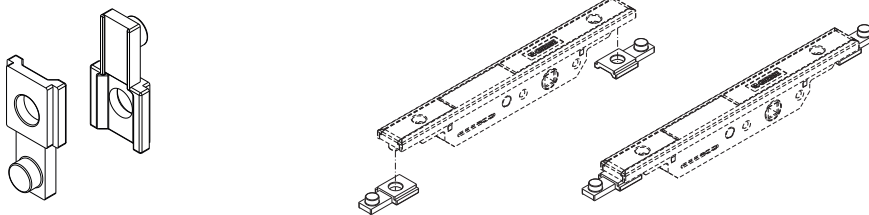

Item code	Description	Type	Opening	PROFILE CROSS - SECTION	Pins/Screws	Finish	Base Raw	Anodised Elox	Painted	Trend/Gold Brass	Pieces per pack
00948	TWO-WAY INTERNAL MECHANISM	D	Inward opening	C001-C002-C003-C004-C005-C006-C012-C013-C014-C015-C016-C017	3,9x19	GS Silver Plus	X				10
0102001	TWO-WAY INTERNAL MECHANISM	A	Inward opening	C001-C002-C003-C004-C005-C006-C009-C010-C012-C013-C014-C015-C016-C017-P001-P002-P004-P005-P006-P007-P008-P009-P010	-	GS Silver Plus	X				5
0102101	TWO-WAY INTERNAL MECHANISM	B	Inward opening	C011	M5x60	GS Silver Plus	X				5
0102301	TWO-WAY INTERNAL MECHANISM	B	Inward opening	*	M5x35	GS Silver Plus	X				5
01025K	TWO-WAY INTERNAL MECHANISM	C	Pivoting, Awning	*	-	GS Silver Plus	X				5
01026K	TWO-WAY INTERNAL MECHANISM	C	Pivoting, Awning	*	-	GS Silver Plus	X				5
01190	R40 ADAPTER KIT FOR TWO-WAY INWARD MOVEMENT	E	Inward opening	C007	-	GS Silver Plus	X				10

* Refer to the online catalog for exact series/code matching.

ONE-WAY INTERNAL MECHANISMS

Functions

One-way mechanism, operated by window handle, to be inserted in the tubular section of the profile to operate the GIESSE tilt-and-turn sash fastening mechanisms.

Online data sheet



Technical Features

The mechanisms are reversible and designed to be combined with all the window handles made by GIESSE, both in aluminium and brass (with 7 mm square spindle).

The shim supplied, to be placed inside the tubular section of the profile, between the mechanism and the window handle, enables perfect alignment of the parts.

Materials

Rack, case, incorrect movement safety device slide, cover for mechanism and gear in die-cast zamak.

Shims in black polyamide.

Screws and spring of zinc-nickel plated steel.

Type A

Type A: dimensions

Type A: machining

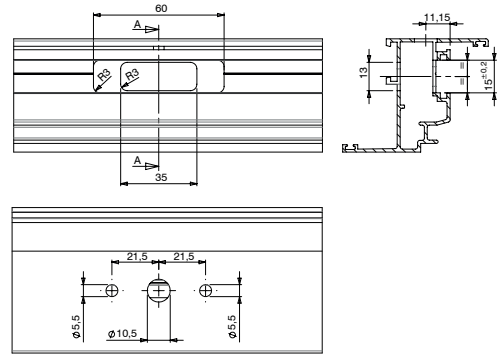
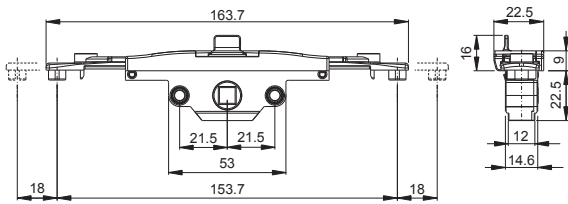
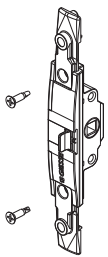

Type B

Type B: dimensions

Type B: machining

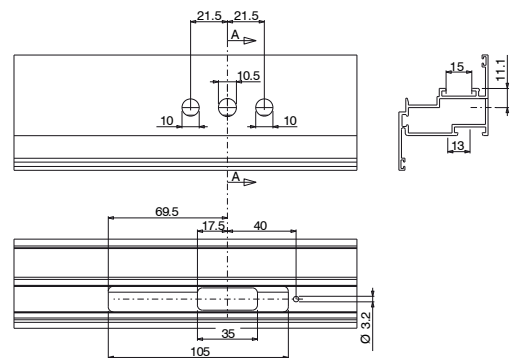
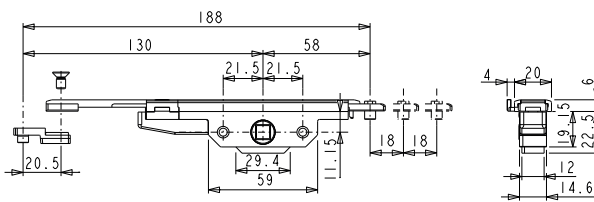
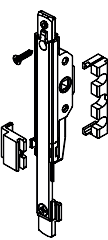

Type C

Type C: dimensions

Type C: machining

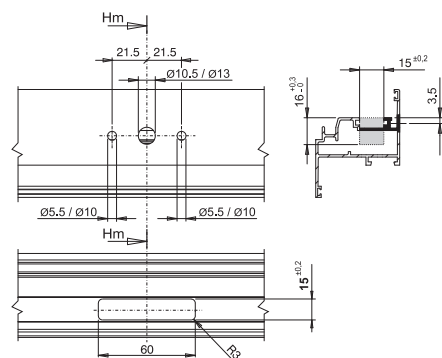
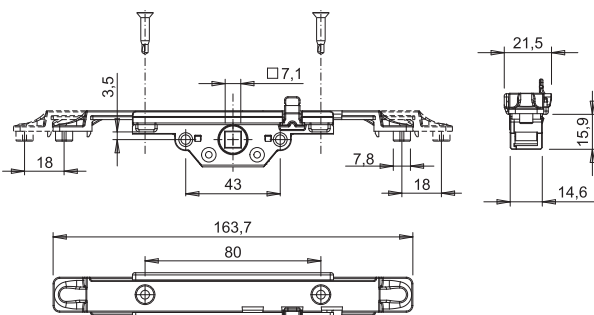
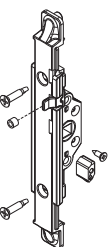

Item code	Description	Type	PROFILE CROSS - SECTION	Screws	Finish	Base Raw	Anodised Elox	Painted	Trend/Gold Brass	Pieces per pack
00949	ONE-WAY MECHANISM M180	C	C001-C002-C003-C004-C005-C006-C012-C013-C014-C015-C016-C017	-	GS Silver Plus	X				10
00986	SINGLE-DIR.INT.DEV.E.G. M180 W/O INC.MOV	A	C001-C002-C003-C004-C005-C006-C012-C013-C014-C015-C016-C017	3,9x16	GS Silver Plus	X				10
01029K	ONE-WAY MECHANISM M180	B	C001-C002-C003-C004-C005-C006-C012-C013-C014-C015-C016-C017	-	GS Silver Plus	X				5
0103001	ONE-WAY MECHANISM M180	B	C011	M5x60	GS Silver Plus	X				5
0106101	ONE-WAY MECHANISM M180	A	C001-C002-C003-C004-C005-C006-C012-C013-C014-C015-C016-C017	-	GS Silver Plus	X				10
01062	ONE-WAY MECHANISM M180	A	C007	-	GS Silver Plus	X				10

TWO-WAY MECHANISM FOR GHIBO OUT OUTWARD OPENING



Functions

Ghibo out is a two-way device, to be housed in the tubular profile that, via a window handle, moves the rods and locking points of outward-opening side-hung windows.

Online data sheet



Technical Features

Ideal for outward-opening side-hung windows (Side Hung, shutters, etc.). These devices are reversible and are ready to be fitted on either right or left sashes.

The long two-way stroke of the hardware of 18 mm thus allows plenty of overlap of the fastening components.

It is recommended to use these mechanisms in combination with fastening bolt tips type art. 02114K and sill strikers type art. 02159.

The mechanisms are designed to accommodate a 7 mm square pin and to be combined with all the window handles made by GIESSE, both of aluminium and brass, with a 43 mm fixing C/C distance.

The product is secured to the sash profile with the two screws supplied.

The two polyamide tubes supplied are to be placed inside the tubular profile and they perform the function of a spacer between the base of the window handle and the mechanism, allowing the mechanism to maintain perfect alignment of the parts.

Materials

Case and connection devices to transmit motion in silver painted zamak

Rotor in zinc plated zamak

Tubes and bushings of black polyamide

Stainless steel fixing screws

Example of application

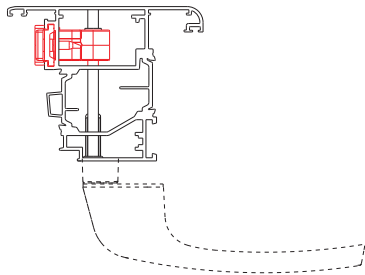

art. 04093 E= 29
stroke 18 mm

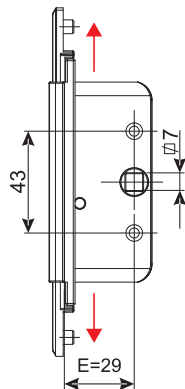

art. 04094 E= 23
stroke 17 mm

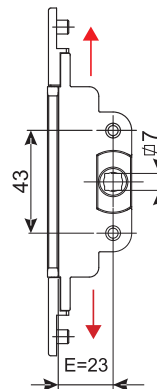

art. 04108 E= 35
stroke 18 mm

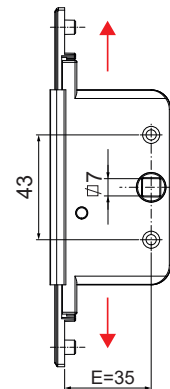

art. 00934-00935-00936-00937-00938-00943

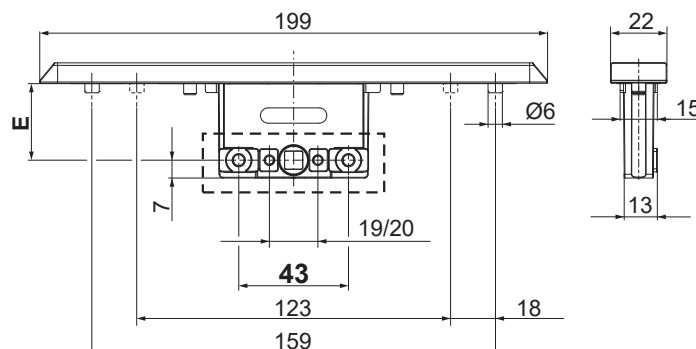
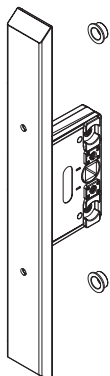

INTERNAL MECHANISMS

Item code	Description	Opening	Stroke	Backset E [mm]	Note	Base Raw	Anodised Elox	Painted	Trend/Gold Brass	Pieces per pack
00934	GHIBO OUT TWO-WAY MECHANISM	Outward-opening side-hung window	18 mm	11	Compatible with Window Handles with 7 mm square pin - fixing c/c distance 43 mm	X				6
00935	GHIBO OUT TWO-WAY MECHANISM	Outward-opening side-hung window	18 mm	15	Compatible with Window Handles with 7 mm square pin - fixing c/c distance 43 mm	X				6
00936	GHIBO OUT TWO-WAY MECHANISM	Outward-opening side-hung window	18 mm	22	Compatible with Window Handles with 7 mm square pin - fixing c/c distance 43 mm	X				6
00937	GHIBO OUT TWO-WAY MECHANISM	Outward-opening side-hung window	18 mm	30	Compatible with Window Handles with 7 mm square pin - fixing c/c distance 43 mm	X				6
00938	GHIBO OUT TWO-WAY MECHANISM	Outward-opening side-hung window	18 mm	35	Compatible with Window Handles with 7 mm square pin - fixing c/c distance 43 mm	X				6
00943	GHIBO OUT TWO-WAY MECHANISM	Outward-opening side-hung window	18 mm	25	Compatible with Window Handles with 7 mm square pin - fixing c/c distance 43 mm	X				6
04093	GHIBO OUT TWO-WAY MECHANISM	Outward-opening side-hung window	18 mm	29	Compatible with Window Handles with 7 mm square pin - fixing c/c distance 43 mm	X				5
04094	GHIBO OUT TWO-WAY MECHANISM	Outward-opening side-hung window	17 mm	23	Compatible with Window Handles with 7 mm square pin - fixing c/c distance 43 mm	X				5
04108	GHIBO OUT TWO-WAY MECHANISM	Outward-opening side-hung window	18 mm	35	Compatible with Window Handles with 7 mm square pin - fixing c/c distance 43 mm	X				5

ONE-WAY MECHANISM FOR GHIBO OUT OUTWARD OPENING

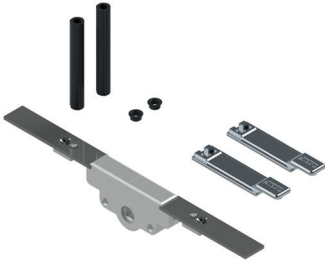

Functions

The one-way Ghibo out internal mechanism is housed in the hollow section of the profile and, via a window handle, moves the rods and locking points of outward-opening side-hung windows.

Online data sheet



Technical Features

Ideal for outward-opening side-hung windows (Side Hung, doorways, etc.). This device is reversible and is ready to be fitted on either right or left sashes. The depths of the mechanisms are:

- 22 mm
- 27 mm
- 32 mm

Products make a one-way stroke of 18 mm thus allowing plenty of overlap of the fastening components.

It is recommended to use this mechanism in combination with fastening pawls type art. 04030K and strikers type art. 01343K.

The mechanism is designed to accommodate a 7 mm square pin and to be combined with all the window handles made by GIESSE, both of aluminium and brass, with a 43 mm fixing C/C distance.

The product is secured to the sash profile with screws, not supplied.

It is possible to combine the mechanisms Art. 04082/04083/04084 with the Ghibo Key Out mechanism Art. 04086/04087/04088. With these products you can lock the sliding of the fastening rod via a Euro cylinder (not supplied).

Materials

Front plate and sliding component of steel
Case, rotor and connection devices to transmit motion in silver painted zamak
Tubes and bushings of black polyamide

Parts

- 2 polyamide tubes
- 2 rod - mechanism connection components
- 2 bushings for coupling on rods with 8 mm hole

Example of application

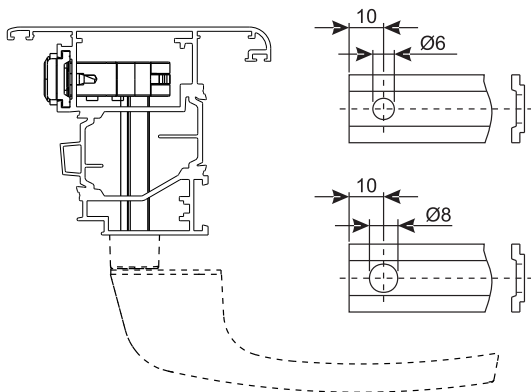

Type A

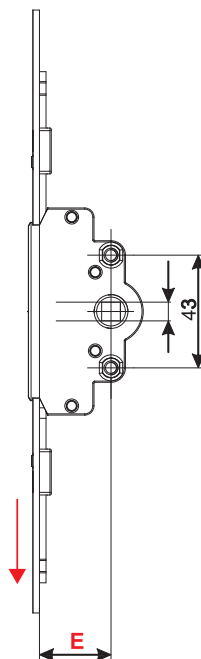

Type B

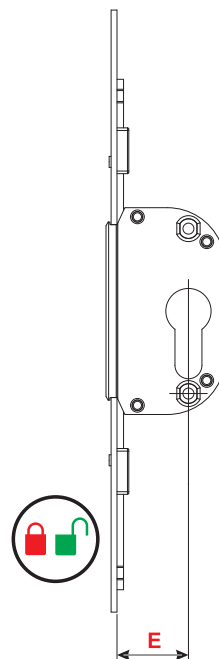

Type C

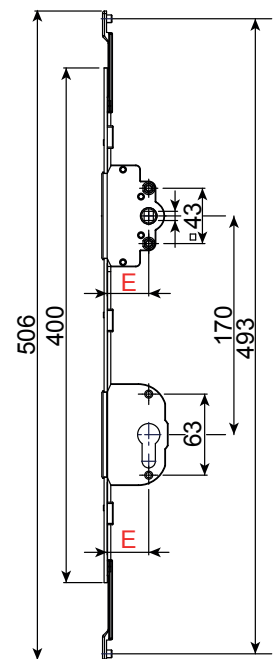

A = Ghibo Out mechanism
 B = Hardware for Ghibo Out mechanism

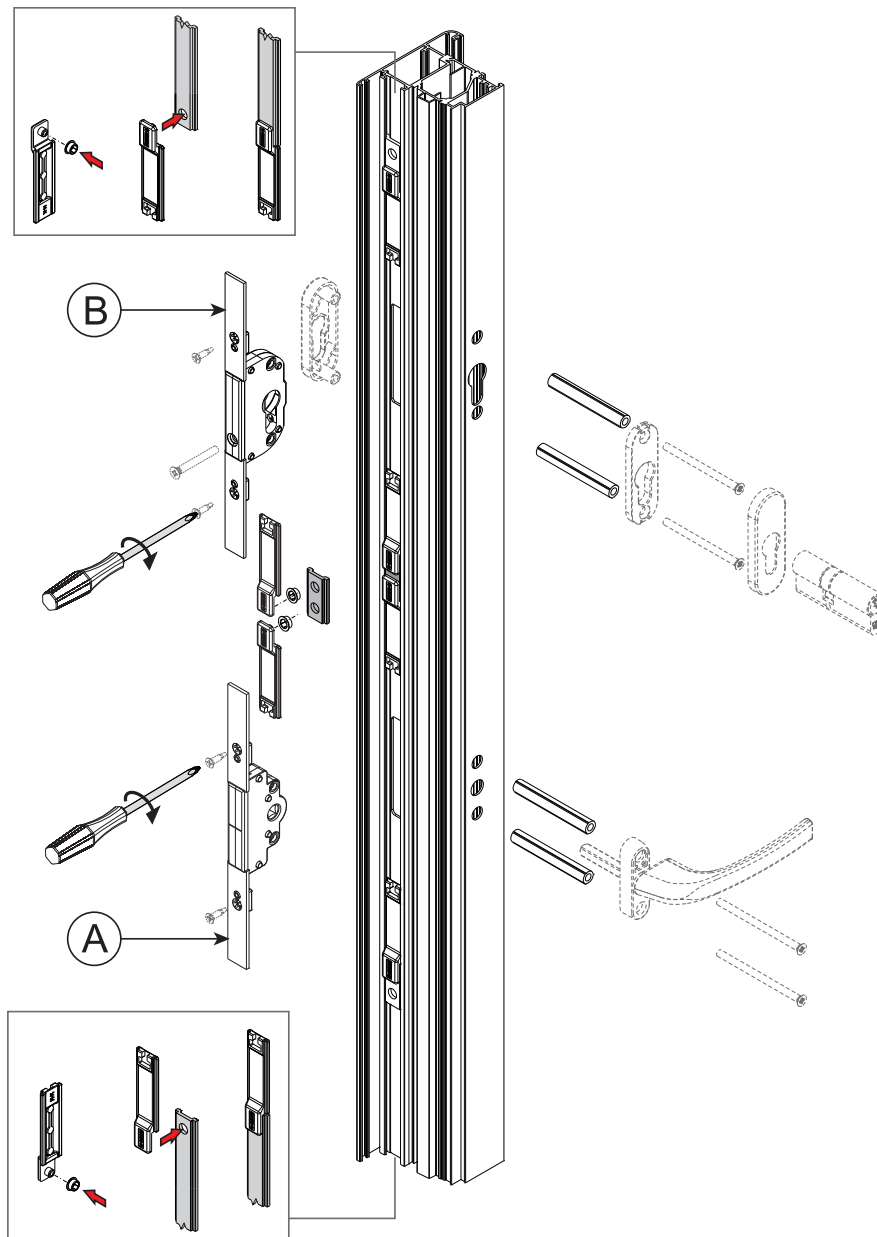

INTERNAL MECHANISMS

Item code	Description	Opening	Drawing	Technical notes	Backset	Note	Base Raw	Anodised Elox	Painted	Trend/Gold Brass	Pieces per pack
04082	GHIBO OUT ONE-WAY MECHANISM - BS 22	Outward-opening side-hung window	Type A	stroke 18 mm	E=22 mm		X				5
04083	GHIBO OUT ONE-WAY MECHANISM - BS 27	Outward-opening side-hung window	Type A	stroke 18 mm	E=27 mm		X				5
04084	GHIBO OUT ONE-WAY MECHANISM - BS 32	Outward-opening side-hung window	Type A	stroke 18 mm	E =32 mm		X				5
04086	MECHANISM FOR GHIBO OUT KEY ONE-WAY MECHANISM - BS 22	Outward-opening side-hung window	Type B	for art. 04082 - Compatible with standard European cylinders and Art. 04095-04096	E=22 mm		X				5
04106	ONE-WAY MECHANISM GHIBO OUT WITH KEY - BS 32	Outward-opening side-hung window	Type C	stroke 18 mm	E =32 mm	Single rod, integrating both the mechanism and the key block	X				5
04143	ONE-WAY MECHANISM GHIBO OUT WITH KEY - BS 22" INOX	Outward-opening side-hung window	Type A	stroke 18 mm	E =22 mm		X				5
04144	ONE-WAY MECHANISM GHIBO OUT WITH KEY - BS 27" INOX	Outward-opening side-hung window	Type A	stroke 18 mm	E =27 mm		X				5
04145	ONE-WAY MECHANISM GHIBO OUT WITH KEY - BS 32" INOX	Outward-opening side-hung window	Type A	stroke 18 mm	E =32 mm		X				5
04146	ONE-WAY MECHANISM GHIBO OUT WITH KEY - BS 22" INOX	Outward-opening side-hung window	Type B	for art. 04143 - Compatible with standard European cylinders and Art. 04095-04096	E =22 mm		X				5
04147	ONE-WAY MECHANISM GHIBO OUT WITH KEY - BS 27" INOX	Outward-opening side-hung window	Type B	for art. 04144 - Compatible with standard European cylinders and Art. 04095-04096	E =27 mm		X				5
04148	ONE-WAY MECHANISM GHIBO OUT WITH KEY - BS 32" INOX	Outward-opening side-hung window	Type B	for art. 04145 - Compatible with standard European cylinders and Art. 04095-04096	E =32 mm		X				5
04149	ONE-WAY MECHANISM GHIBO OUT WITH KEY - BS 22" INOX	Outward-opening side-hung window	Type C	stroke 18 mm	E =22 mm	Single rod, integrating both the mechanism and the key block	X				5
04151	ONE-WAY MECHANISM GHIBO OUT WITH KEY - BS 27" INOX	Outward-opening side-hung window	Type C	stroke 18 mm	E =27 mm	Single rod, integrating both the mechanism and the key block	X				5
04152	ONE-WAY MECHANISM GHIBO OUT WITH KEY - BS 32" INOX	Outward-opening side-hung window	Type C	stroke 18 mm	E =32 mm	Single rod, integrating both the mechanism and the key block	X				5

GHIBO ONE-WAY M180 OUTWARD OPENING MECHANISMS

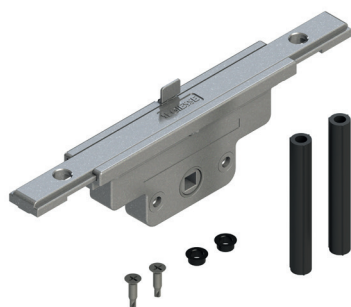
**Functions**

The one-way Ghibo out internal mechanism is housed in the hollow section of the profile and, via a window handle, moves the rods and locking points of outward-opening side-hung windows. It is equipped with an incorrect movement safety device.

Online data sheet

**Technical Features**

Ideal for outward-opening side-hung windows (Side Hung, doorways, etc.). This device is reversible and is ready to be fitted on either right or left sashes. The mechanism is equipped with an incorrect movement safety device and has a stroke of 36 mm (18 + 18).

It is designed to accommodate a 7 mm square spindle and to be combined with all the window handles made by GIESSE, both of aluminium and brass, with a 43 mm fixing C/C distance.

The product is secured to the sash profile with the screws supplied.

Materials

Case and connection devices to transmit motion and rotor made of zamak

Incorrect movement safety device made of stainless steel

Tubes and bushings of black polyamide

Stainless steel fixing screws

Overall dimensions

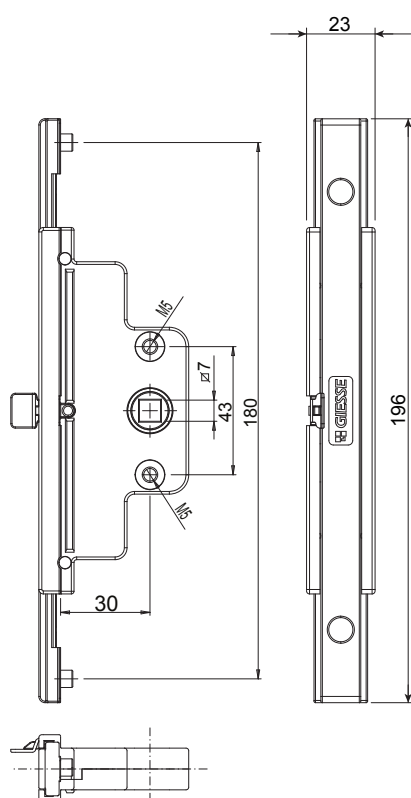

Example of application

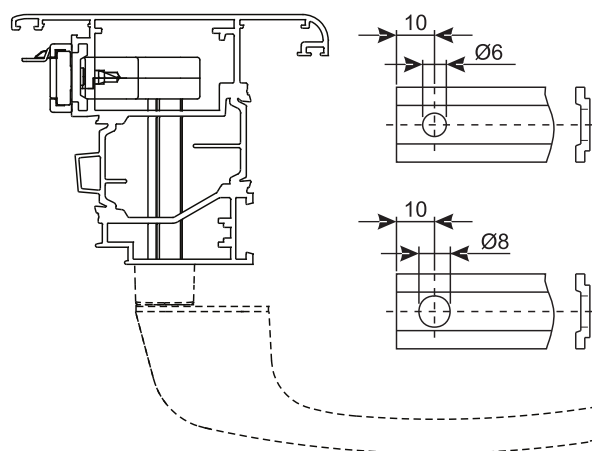

INTERNAL MECHANISMS

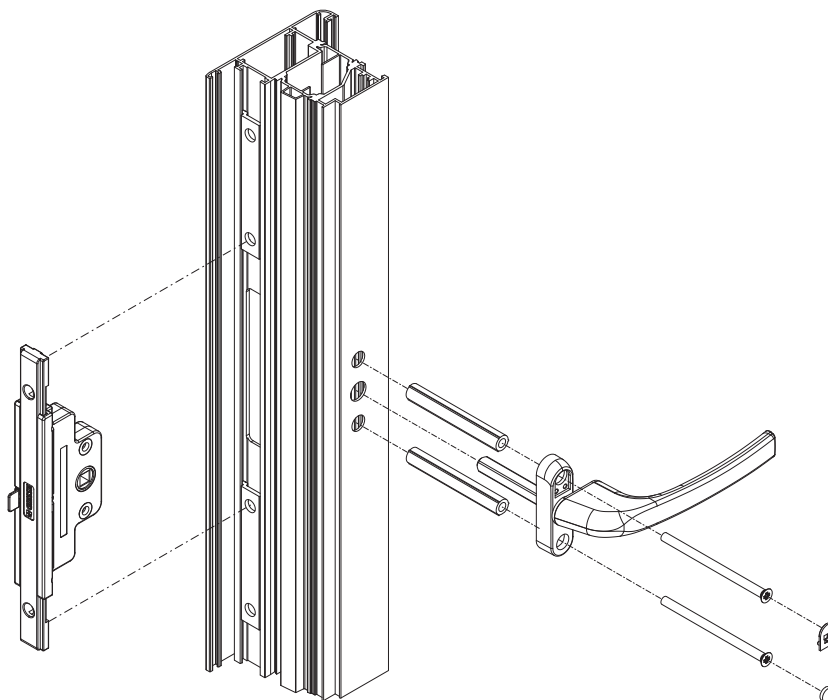

Item code	Description	Opening	Technical notes	Backset	Base Raw	Anodised Elox	Painted	Trend/Gold Brass	Pieces per pack
04089	ONE-WAY MECHANISM M180 BS 30	Outward-opening side-hung window	stroke 36 mm	E= mm 30	X				5

ONE-WAY MOVEMENT GHIBO PLUS CW1

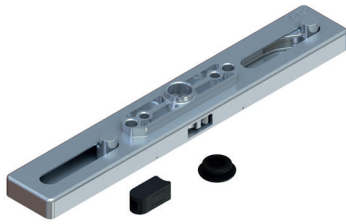
**Functions**

The Ghibo Plus movement is a one-way device, to be housed on a sash profile of a curtain wall for the rods and fastening pawls movement through a window handle.

Online data sheet

**Technical Features**

The mechanism has a stroke of 36 mm and ensures an excellent grip of the pawls (sash) on the strikers (frame).

The mechanism is particularly strong and has a cover made of stainless steel. The C/C distance of the fixing holes is 43 mm and the rotor has a square hole of 7 mm: this ensures the mechanism is compatible with all the window handles on the market.

The movement is compatible with rods with 8 mm hole.

Materials

Housing in Zamak
Stainless steel cover
Polyamide bushes

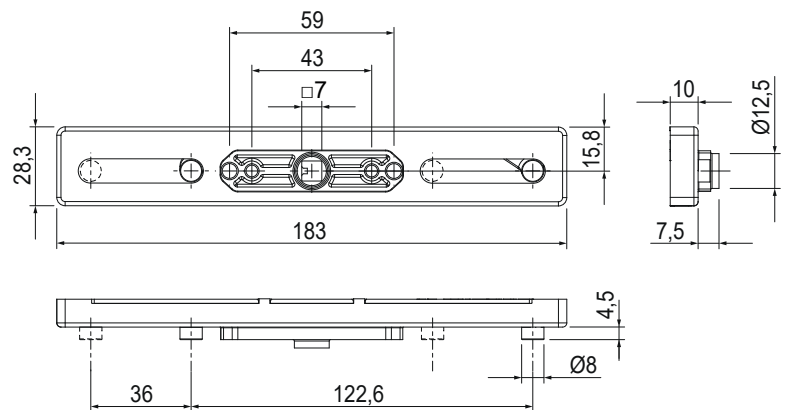
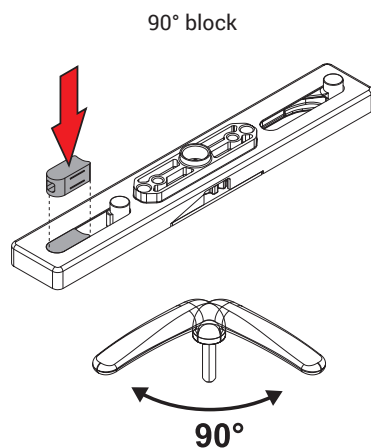
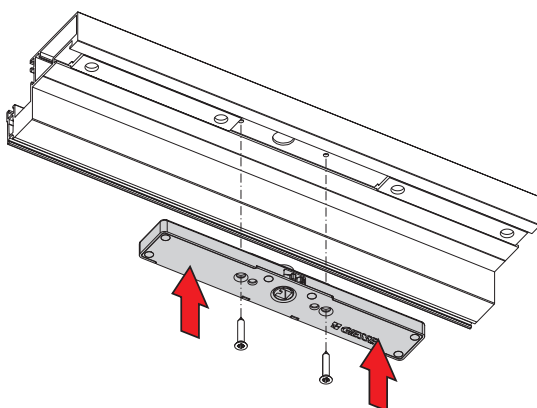
**Application on profile**

PRIMA PLUS HANDLE



Functions

Pair of aluminium handles, reversible with stop, for fitting on the upright or centre rail of the door.

Online data sheet



Technical Features

The PRIMA PLUS handle comprises a case, plate and rotor which, combined with a return spring, enables reversible operation and horizontal positioning of the handle.

Instant access to the fixing screws by simply rotating the plate cover.

The double C/C distance of the drilling, 43 and 50 mm, enables the handle to be fitted on the majority of profiles available on the market. Fixing to the profile is done with the self-tapping screws $\varnothing 4.2 \times 16$ supplied with the handle.

The base has 4 holes, with c/c distance 38 mm, for using additional screws (not provided) when changing the handle.

The handle rotor is equipped with a mechanical stop that safeguards the end stroke of the spring, preventing damage and consequent breakage, in case of incorrect operation.

The 110 mm square pin supplied lets you install the handle on profiles from 78 to 82 mm wide (without cutting the pin).

The handle is protected and finished using the GIESSE painting system, which guarantees high quality surfaces, uniformity of colour and excellent resistance to abrasions.

The components are pretreated to guarantee resistance to surface scaling.

Materials

Handle made of die-cast aluminium (painted versions) or zamak (Trend finishes)

Expansion rotor and plate made of galvanised zamak

Self-forming screw for fixing to the rotor made of zinc-plated steel

Plate cover made of zamak

Compression spring made of stainless steel

Steel return spring

Screws for fixing to the profile and square pin

8x8x110 in zinc plated steel

Shim washers made of acetal resin

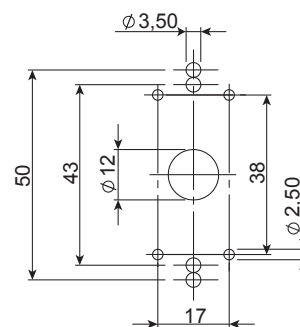
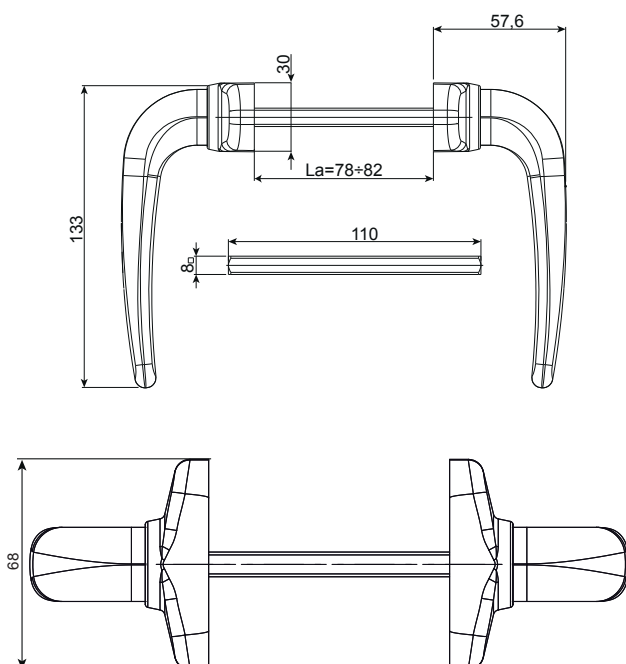

Item code	Description	Note	Square spindle [mm]	La [mm]	Base Raw	Anodised Elox	Painted	Trend/Gold Brass	Pieces per pack
02792	PRIMA HANDLE	pair	8x8x110	78-82	X		X	X	10

MASTERMONT HANDLE



Functions

Pair of reversible aluminium handles for fitting on the upright or centre rail of the door.

Online data sheet



Technical Features

The MASTER MONT handle is composed of two handles, two flat pins and two fixing plates.

The aluminium pull handle has the same styling as the EURO line of cremones. The handle is applicable on profiles of up to 65 mm wide without cutting the spindle.

Materials

Handle in aluminium
Flat pins 8x4x122 in zinc plated steel
Polyamide fixing plate
Fixing screws, zinc-coated steel
Nickel-plated steel grub screws

Parts

2 Pins 8x4x12 mm
4 CSH self-tapping screws 3.5x13
2 Grub screws M6x10

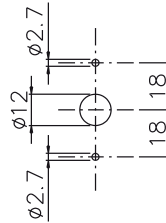
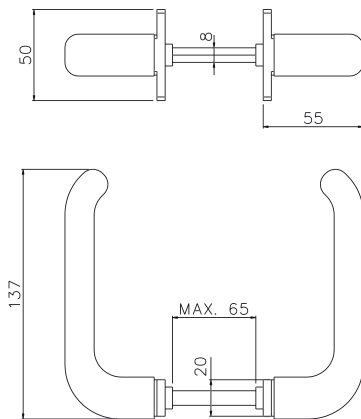

Item code	Description	Note	Base Raw	Anodised Elox	Painted	Trend/Gold Brass	Pieces per pack
02458	MASTERMONT HANDLE	pair	X		X		20

ASIA HANDLE



Functions

Pair of aluminium handles, reversible with stop, for fitting on the upright or centre rail of the door.

Online data sheet



Technical Features

The ASIA door handle comprises a base and a rotor which, combined with a return spring, enables reversible operation and horizontal positioning of the handle.

Instant access to the fixing screws by simply rotating the plate cover.

The double C/C distance of the drilling, 43 and 50 mm, enables the handle to be fitted on the majority of profiles available on the market. Fixing to the profile is done with the self-tapping screws $\varnothing 4.2 \times 16$ supplied with the handle.

The base has 4 holes, with c/c distance 38 mm, for using additional screws (not provided) when changing the handle.

The handle rotor is equipped with a mechanical stop that safeguards the end stroke of the spring, preventing damage and consequent breakage, in case of incorrect operation.

The 110 mm square pin supplied lets you install the handle on profiles from 78 to 82 mm wide (without cutting the pin).

The handle is protected and finished using the GIESSE painting system, which guarantees high quality surfaces, uniformity of colour and excellent resistance to abrasions.

The components are pretreated to guarantee resistance to surface scaling.

Materials

Handle in die-cast aluminium

Rotor in zinc plated zamak

Self-forming screw for fixing to the rotor made of zinc-plated steel

Base and cover made of painted zamak

Compression spring made of stainless steel

Steel return spring

Screws for fixing to the profile and square pin

8x8x110 in zinc plated steel

Shim washers made of acetal resin

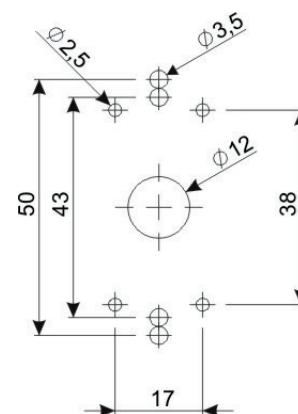
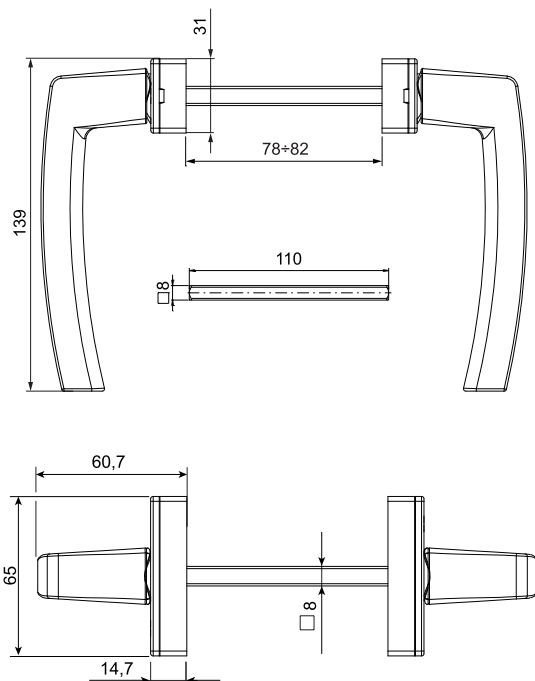

Item code	Description	Note	Square spindle [mm]	Base Raw	Anodised Elox	Painted	Trend/Gold Brass	Pieces per pack
02414	ASIA HANDLE	pair	8x8x110	X		X		10

KORA DOOR HANDLES

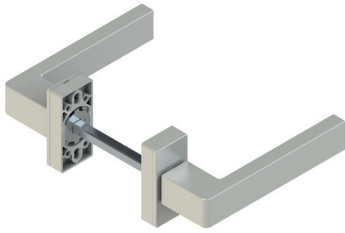

Functions

Pair of aluminium handles, reversible with stop, for fitting on the upright or centre rail of the door.

Online data sheet



Technical Features

The KORA door handle comprises a base and a rotor which, combined with a return spring, enables reversible operation and horizontal positioning of the handle.

Instant access to the fixing screws by simply rotating the plate cover.

The double C/C distance of the drilling, 43 and 50 mm, enables the handle to be fitted on the majority of profiles available on the market. Fixing to the profile is done with the self-tapping screws $\varnothing 4.2 \times 16$ supplied with the handle.

The base has 4 holes, with c/c distance 38 mm, for using additional screws (not provided) when changing the handle.

The handle rotor is equipped with a mechanical stop that safeguards the end stroke of the spring, preventing damage and consequent breakage, in case of incorrect operation.

The 110 mm square pin supplied lets you install the handle on profiles from 78 to 82 mm wide (without cutting the pin).

The handle is protected and finished using the GIESSE painting system, which guarantees high quality surfaces, uniformity of colour and excellent resistance to abrasions.

The components are pretreated to guarantee resistance to surface scaling.

Materials

Handle in die-cast aluminium

Rotor in zinc plated zamak

Self-forming screw for fixing to the rotor made of zinc-plated steel

Base and cover made of painted zamak

Compression spring made of stainless steel

Steel return spring

Screws for fixing to the profile and square pin

8x8x110 in zinc plated steel

Shim washers made of acetal resin

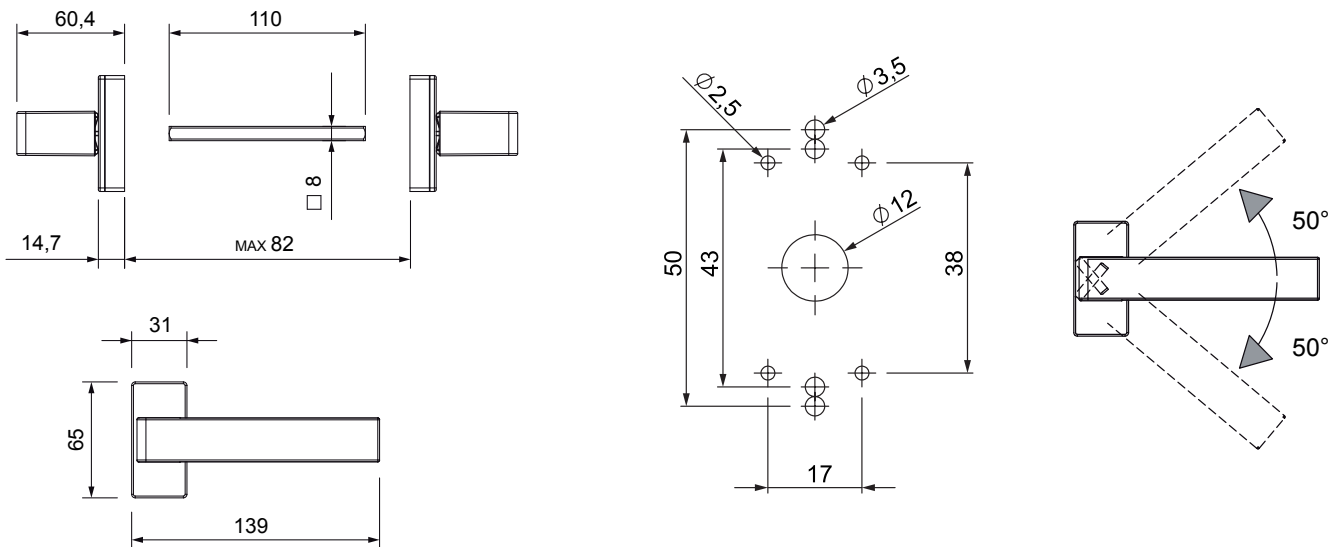

Item code	Description	Note	Square spindle [mm]	Base Raw	Anodised Elox	Painted	Trend/Gold Brass	Pieces per pack
02563	KORA DOOR HANDLE	pair	8x8x110	X		X	X	10

MASTER PLUS HANDLE



Functions

Pair of aluminium handles, reversible with stop, for fitting on the upright or centre rail of the door.

Online data sheet



Technical Features

The MASTER PLUS door handle comprises a base and a rotor which, combined with a return spring, allows reversible operation and horizontal positioning of the handle.

Instant access to the fixing screws by simply rotating the plate cover.

The double C/C distance of the drilling, 43 and 50 mm, enables the handle to be fitted on the majority of profiles available on the market.

Fixing to the profile is carried out using the $\varnothing 4.2 \times 16$ self-threading screws supplied with the handle.

The base has 4 holes, with c/c distance 38 mm, for using additional screws (not provided) when changing the handle.

The handle rotor is equipped with a mechanical stop that safeguards the end stroke of the spring, preventing damage and consequent breakage, in case of incorrect operation.

The 110 mm square pin supplied lets you install the handle on profiles from 78 to 82 mm wide (without cutting the pin).

The handle is protected and finished using the GIESSE painting system, which guarantees high quality surfaces, uniformity of colour and excellent resistance to abrasions.

The components are pretreated to guarantee resistance to surface scaling.

Materials

Handle in die-cast aluminium

Rotor in zinc plated zamak

Self-forming screw for fixing to the rotor made of zinc-plated steel

Base and cover made of painted zamak

Compression spring made of stainless steel

Steel return spring

Screws for fixing to the profile and square pin

8x8x110 in zinc plated steel

Shim washers made of acetal resin

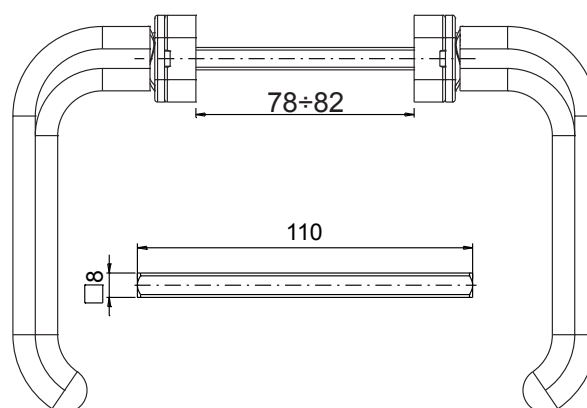

DOOR HANDLES

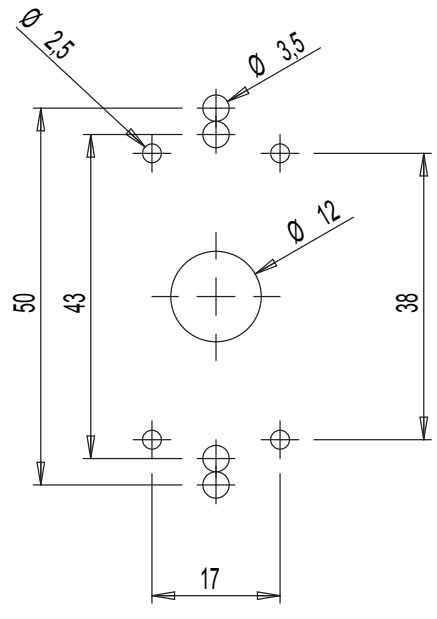
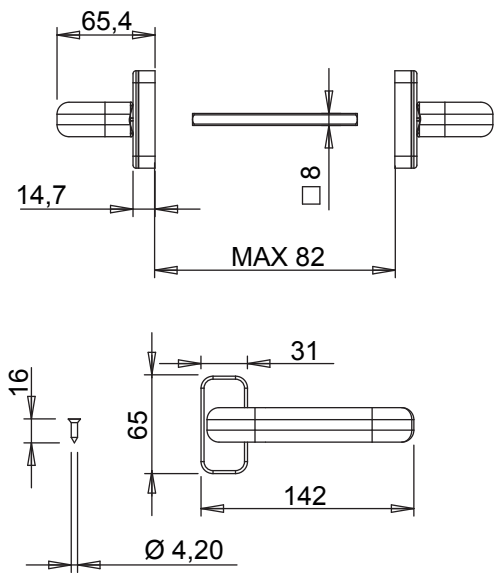

Item code	Description	Note	Square spindle [mm]	Base Raw	Anodised Elox	Painted	Trend/Gold Brass	Pieces per pack
02422	MASTER PLUS HANDLE	pair	8x8x110	X		X		10

MASTERPLAST HANDLE



Functions

Pair of polyamide handles, reversible with stop, for fitting on the upright or centre rail of the door.

Online data sheet



Technical Features

The MASTERPLAST handle is composed of a pair of handles, completely pre-assembled, and an 8 mm square pin.

The pull handle is pre-assembled to the plate for fixing to the profile, to the screw cap cover and to the rotor with the spring which enables reversible operation, stopping and horizontal positioning of the handle.

The pull handle of the handle has the same styling as the EURO line cremones. The handle is applicable on profiles of from 45 to 55 mm wide without cutting the spindle.

Materials

Base, cover and handle made of polyamide (red/black)

Rotor in zinc plated zamak

Acetal resin spring

Square pin 8x8x110 and fixing screws in zinc plated steel.

Parts

1 Square pin mm. 8x8X110

4 Self-tapping zinc plated cross-slotted screws 4.2x19

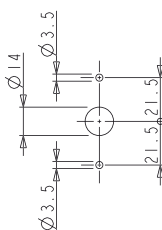
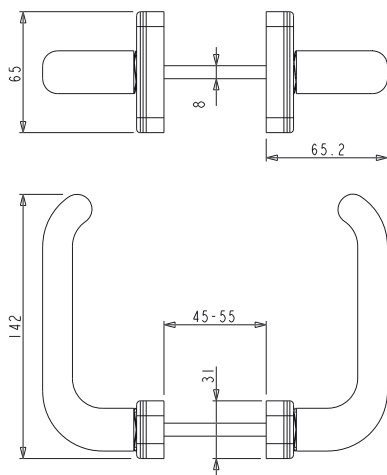

Item code	Description	Note	Base Raw	Anodised Elox	Painted	Trend/Gold Brass	Pieces per pack
02456	MASTERPLAST HANDLE	black polyamide	X				20

CYLINDER COVER PLATES

Functions

Cylinder cover plates for European profile cylinder.

Online data sheet



Technical Features

The cover plate is composed of a plate that is fixed to the profile by self-threading screws and a cover that is snap-fixed on the plate. The cover plate design matches that of its handle.

Materials

External cover plate made of aluminium or painted zamak
 Polyamide cover plate sub-base
 Zinc plated steel screws

European cylinder machining

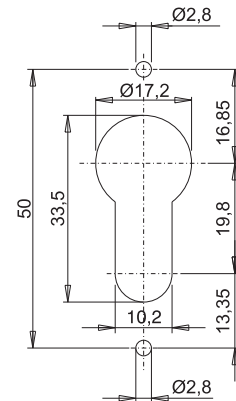

0243001

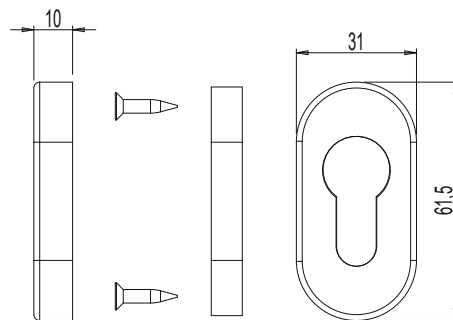
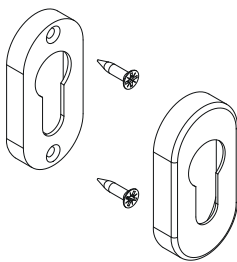

02431

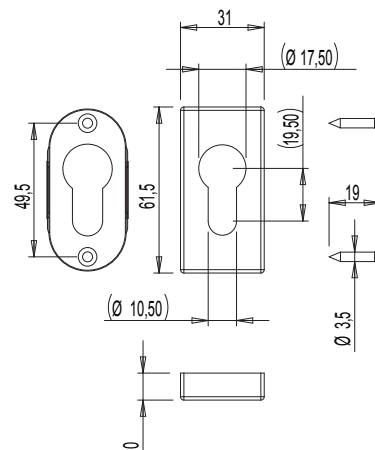
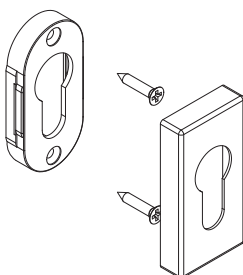

04476N

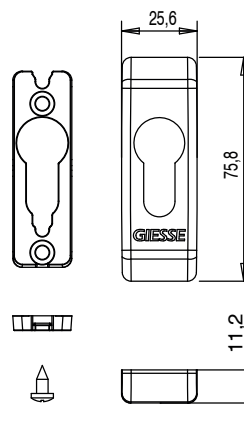
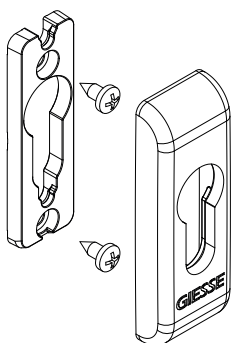

07058N

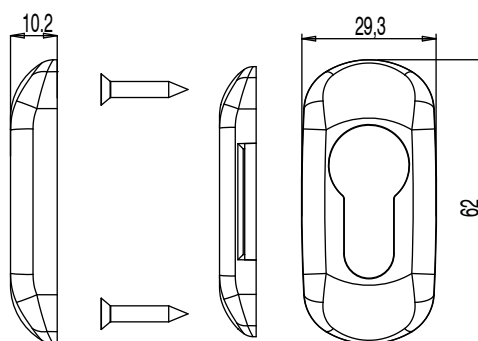
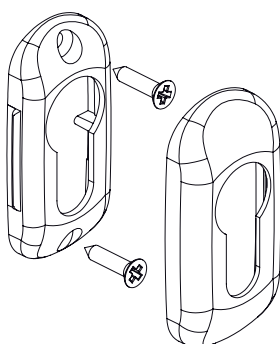

Item code	Description	Note	Base Raw	Anodised Elox	Painted	Trend/Gold Brass	Pieces per pack
0243001	CYLINDER COVER PLATE	1 set= 1 cover + 1 cover plate	X		X	X	20
02431	ASIA CYLINDER COVER PLATE	1 set= 1 cover + 1 cover plate	X		X	X	20
04476N	CYLINDER COVER PLATE	1 set= 1 cover + 1 cover plate	X		X		20
07058N	OVAL ROSETTE FOR MACHINED CYL.	1 set= 2 covers + 2 cover plates	X		X	X	20

GHIBO OUT KEY CYLINDER COVER PLATE



Functions

Cylinder cover plate for European profile cylinder.

[Online data sheet](#)



Technical Features

Cylinder cover plates with European profile for GHIBO OUT KEY mechanisms. Available in IN cylinder cover plate to cover the cylinder on the inside only. The product is compatible only with mechanisms that have a fixing c/c distance of 63 mm such as GHIBO OUT KEY products.

Materials

Internal cover plate of painted aluminium
Polyamide sub-plate
Zinc plated steel screws

Art. 04096

Assembly sequence Art. 04096

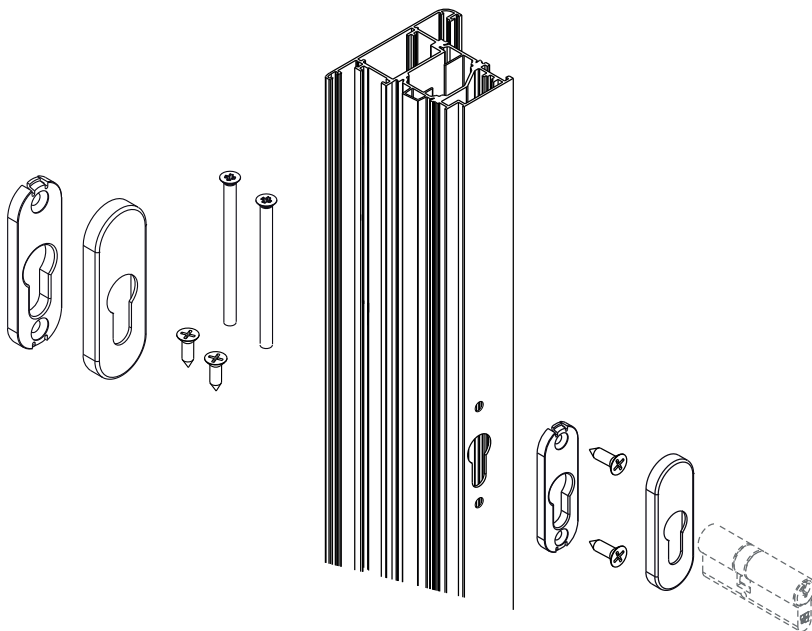

IN cylinder cover plate

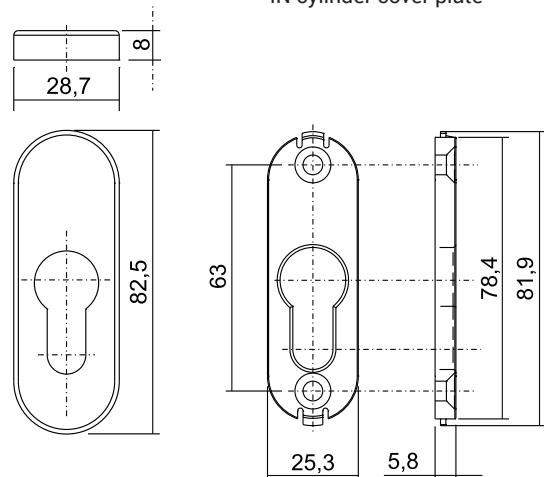

Item code	Description	Technical notes	Base Raw	Anodised Elox	Painted	Trend/Gold Brass	Pieces per pack
04096	IN cylinder cover plate	for art. 04086/87/88 - Compatible with standard European cylinders	X		X		5

LOCKS FOR TOP-BOTTOM LOCKING

**Functions**

Central lock, slip-on version for aluminium stiles, with adjustable spring latch and tilting bolt, ready for rod connection for top/bottom fastening mechanism.

Online data sheet

**Technical Features**

Lock compatible with European profile cylinders, has a burglar-proof tilting bolt and a reversible spring latch (RH or LH), adjustable from 10 to 15 mm.

Bolts operated with the cylinder.

Spring latch operated with the cylinder and with the 8 mm handle spindle.

Cylinder handle C/C distance 85 mm.

Bolt with thickness of 10 mm and minimum protrusion of 24 mm.

Spring latch with 10 to 15 mm protrusion.

The pair of two-way adapters supplied with the lock, for connecting to the polyamide rod, enables making top bottom locking at several points.

Stroke is 15.5 mm.

The adapters for connecting to the rod have connecting pins size 8 mm.

Materials

Lock cover plate and case plate in zinc plated steel

Flat front in stainless steel

Spring latch and bolts in nickel-plated steel

Rod connection adapters in zamak

Polyamide cylinder machining cover studs

Pins for fixing adapters and screw for fixing cylinder in zinc plated steel

Lock fixing screws in stainless steel

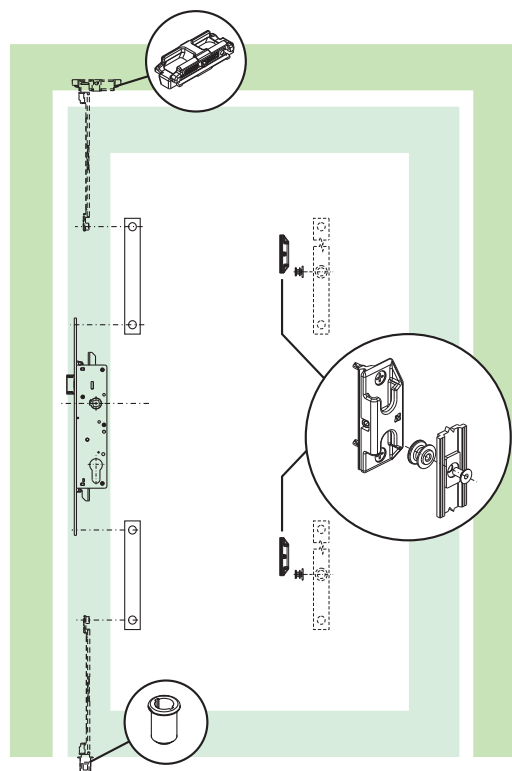
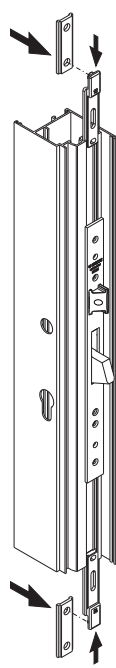
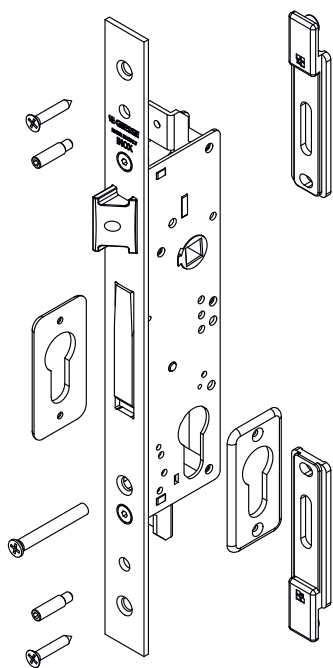

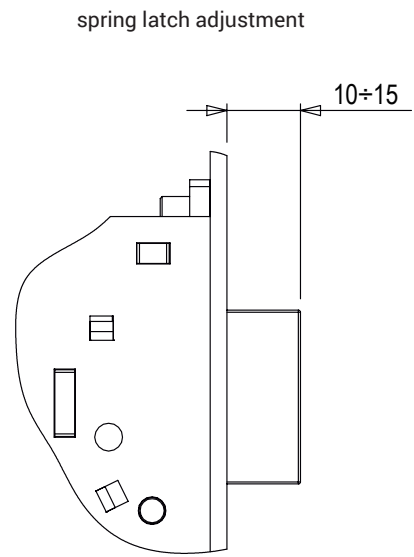
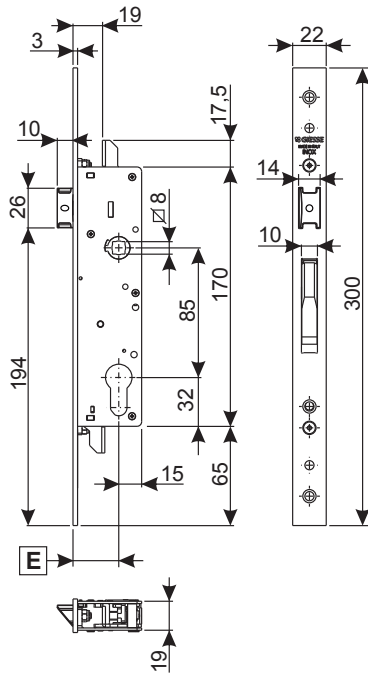

Item code	Description	BACKSET E [mm]	FRONT WIDTH [mm]	PROFILE CROSS - SECTION	Compatible counter-plates	Base Raw	Anodised Elox	Painted	Trend/Gold Brass	Pieces per pack
0462701	LOCK FOR TOP/BOTTOM FASTENING	30	22	04630 - 04639 - 04859 - 04860	X					1
0462801	LOCK FOR TOP/BOTTOM FASTENING	35	22	C001-C002-C003-C004-C005-C006-C009-C010-C011-C012-C013-C014-C016-C017	04630 - 04639 - 04859 - 04860	X				10

LOCKS FOR PERIMETER LOCKING

**Functions**

Central lock with spring latch and bolt, slip-on version for aluminium uprights, with two-way mechanism operated by handle.

Online data sheet

**Technical Features**

Lock compatible with European profile cylinders, available in version with or without bolt.

Coupled with the polyamide rod, via the specific connection adapters, the lock enables making multipoint locking by suitably choosing the number and the position of the lock points on the various sides of the door.

Operation of the spring latch, bolt (on the version fitted with them) and adapters using the 8 mm handle spindle.

Locking and unlocking the handle using the key.

Cylinder handle C/C distance 85 mm and 92 mm.

Bolt with thickness of 6 mm and stroke of 20 mm.

Reversible spring latch (left/right) with 10 mm protrusion.

Stroke is 18 mm.

The adapters for connecting to the rod have connecting pins size 8 mm.

Note: For the lock to function properly it is mandatory to fit a pair of internal/external handles

Materials

Lock cover plate and case plate in zinc plated steel (except for Article 04699 that has a stainless steel body)

Internal components in zinc plated steel

Flat front in stainless steel

Spring latch and bolt in zinc plated zamak

Rod connection adapters in zamak

Pins for fixing adapters and screws for fixing lock in zinc plated steel

Stainless steel cylinder fixing screw

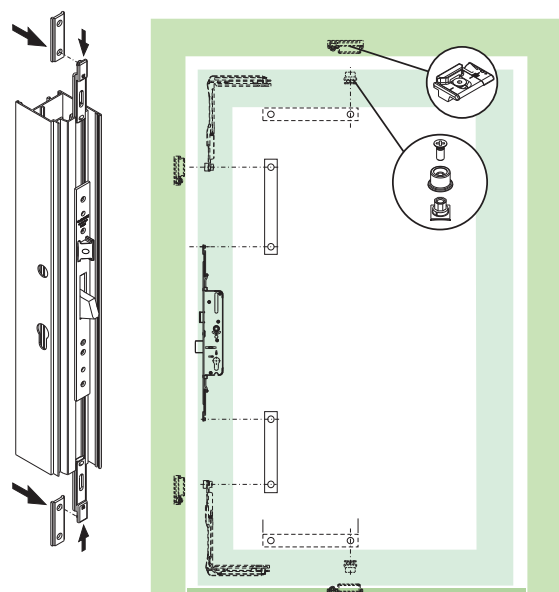
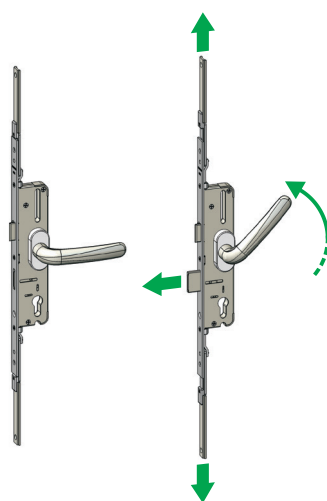
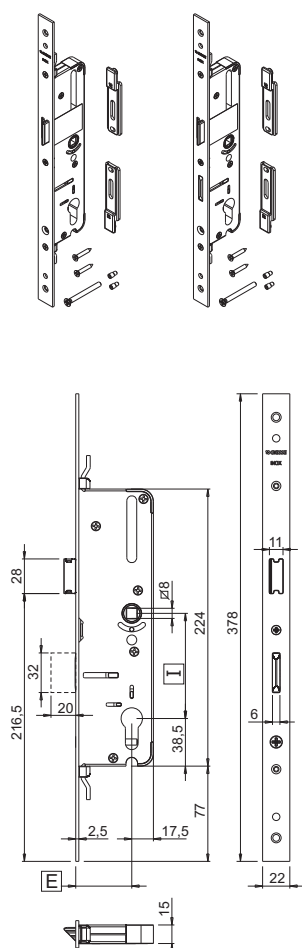

DOOR LOCKS

Item code	Description	BACKSET [mm]	CYLINDER HANDLE C/C DISTANCE [mm]	FRONT WIDTH [mm]	BOLT	PROFILE CROSS - SECTION	COMPATIBLE COUNTER-PLATES	Base Raw	Anodised Elox	Painted	Trend/Gold Brass	Pieces per pack
04645	LOCK FOR PERIMETER FASTENING	35	85	22	NO	C001-C002-C003-C004-C005-C006-C009-C010-C011-C012-C013-C014-C016-C017	04655	X				1
04646	LOCK FOR PERIMETER FASTENING	35	85	22	YES	C001-C002-C003-C004-C005-C006-C009-C010-C011-C012-C013-C014-C016-C017	04655	X				1
04649	LOCK FOR PERIMETER FASTENING	45	85	22	NO	C001-C002-C003-C004-C005-C006-C009-C010-C011-C012-C013-C014-C016-C017	04655	X				1
04650	LOCK FOR PERIMETER FASTENING	45	85	22	YES	C001	04655	X				1
04659	LOCK FOR PERIMETER FASTENING	35	92	22	YES	C001-C002-C003-C004-C005-C006-C009-C010-C011-C012-C013-C014-C016-C017	04655	X				1
04698	LOCK FOR PERIMETER FASTENING	45	92	22	NO	C001-C002-C003-C004-C005-C006-C009-C010-C011-C012-C013-C014-C016-C017	04655	X				1
04699	LOCK FOR PERIMETER FASTENING	45	92	22	YES	C001-C002-C003-C004-C005-C006-C009-C010-C011-C012-C013-C014-C016-C017	04655	X				1



LOCKS WITH SPRING LATCH

Functions

Central lock with front closing, slip-on version for aluminium uprights, with adjustable spring latch and tilting bolt.

Online data sheet



Technical Features

Lock compatible with European profile cylinders, has a burglar-proof tilting bolt and a reversible spring latch (RH or LH), adjustable from 10 to 15 mm. Bolts operated with the cylinder. Spring latch operated with the cylinder and with the 8 mm handle spindle. Cylinder handle C/C distance 85 mm. Bolt with thickness of 10 mm and minimum protrusion of 24 mm. Spring latch with 10 to 15 mm protrusion

Materials

Lock cover plate and case plate in zinc plated steel
 Flat front in stainless steel
 Spring latch and bolts in nickel-plated steel
 Polyamide cylinder machining cover studs
 Zinc plated steel cylinder fixing screw
 Lock fixing screws in stainless steel

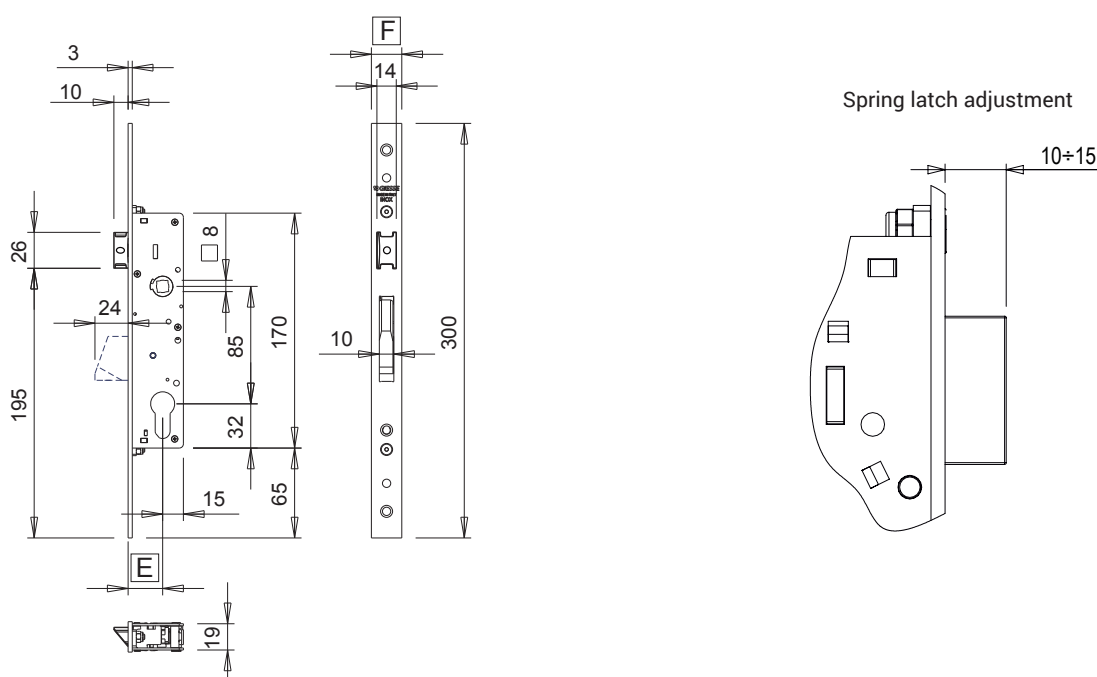

Item code	Description	Backset E [mm]	Front width F [mm]	Compatible counterplates	Base Raw	Anodised Elox	Painted	Trend/Gold Brass	Pieces per pack
0461301	CENTRAL LOCK WITH SPRING LATCH	25	22	04630 - 04639 - 04859 - 04860	X				10
0461401	CENTRAL LOCK WITH SPRING LATCH	30	22	04630 - 04639 - 04859 - 04860	X				10
0461501	CENTRAL LOCK WITH SPRING LATCH	35	22	04630 - 04639 - 04859 - 04860	X				10
0461901	CENTRAL LOCK WITH SPRING LATCH	25	24	04630 - 04639 - 04859 - 04860	X				10
0462001	CENTRAL LOCK WITH SPRING LATCH	30	24	04630 - 04639 - 04859 - 04860	X				10
0462101	CENTRAL LOCK WITH SPRING LATCH	35	24	04630 - 04639 - 04859 - 04860	X				10



LOCKS WITH DEAD BOLT AND SPRING LATCH

Functions

Central lock with front closing, slip-on version for aluminium uprights , with spring latch and sliding bolt.

Online data sheet



Technical Features

Lock compatible with European profile cylinders, has a dead bolt and a reversible spring latch (RH or LH).

Bolts operated with the cylinder.

Spring latch operated with the cylinder and with the 8 mm handle spindle.

Cylinder handle C/C distance 85 mm.

Dead bolt with thickness of 10 mm and protrusion of 15 mm.

10 to 13,5 mm adjustable spring latch.

Materials

Lock cover plate and case plate in zinc plated steel

Flat front in stainless steel

Nickel plated brass spring latch and bolt

Nickel-plated steel bolt

Zinc plated steel cylinder fixing screw

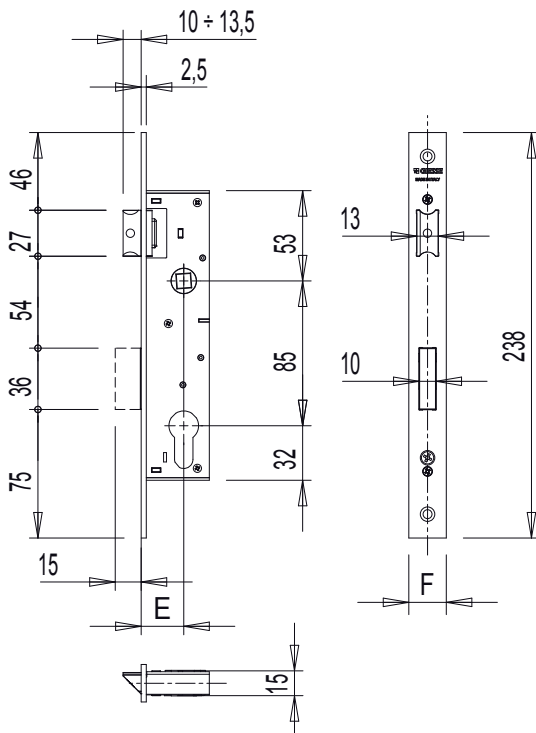

Item code	Description	Backset E [mm]	Front width F [mm]	Compatible counterplates	Base Raw	Anodised Elox	Painted	Trend/Gold Brass	Pieces per pack
0763001	CENTRAL LOCK FRONT E.25 mm	25	22	0465801	X				1
0763101	CENTRAL LOCK FRONT E.30 mm	30	22	0465801	X				1
0763201	CENTRAL LOCK FRONT E.35 mm	35	22	0465801	X				1



ROLLER AND BOLT LOCKS

Functions

Central lock, slip-on version for aluminium uprights, with roller and pivoting bolt.

Online data sheet



Technical Features

Lock compatible with European profile cylinders, has a burglar-proof pivoting bolt and a protrusion adjustable roller.

Bolts operated with the cylinder.

Bolt with thickness of 10 mm and minimum protrusion of 24 mm.

Roller protrusion adjustable from 7 mm to 16,5 mm.

Materials

Lock cover plate and case plate in zinc plated steel

Flat front in stainless steel

Nickel-plated zamak roller

Nickel-plated steel bolt

Polyamide cylinder machining cover studs

Zinc plated steel cylinder fixing screw

Lock fixing screws in stainless steel

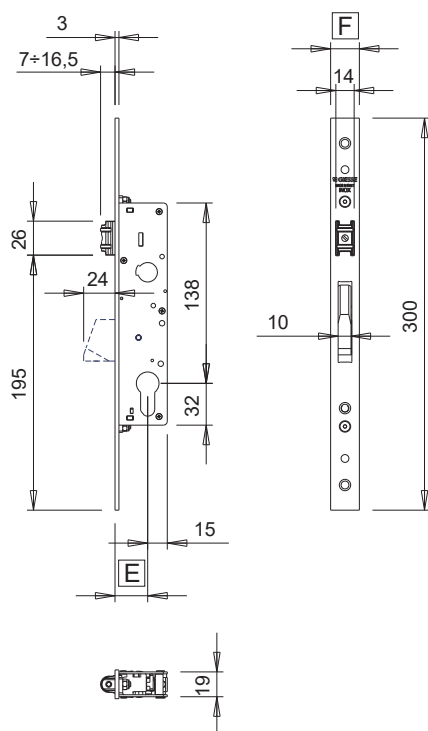

Item code	Description	Backset E [mm]	Front width F [mm]	Compatible counterplates	Base Raw	Anodised Elox	Painted	Trend/Gold Brass	Pieces per pack
04616	CENTRAL LOCK WITH ROLLER	25	22	04630 - 04639 - 04859 - 04860	X				10
04617	CENTRAL LOCK WITH ROLLER	30	22	04630 - 04639 - 04859 - 04860	X				10
04618	CENTRAL LOCK WITH ROLLER	35	22	04630 - 04639 - 04859 - 04860	X				10
04623	CENTRAL LOCK WITH ROLLER	30	24	04630 - 04639 - 04859 - 04860	X				10
04624	CENTRAL LOCK WITH ROLLER	35	24	04630 - 04639 - 04859 - 04860	X				10



MULTIPOINT LOCKS FLAT FRONT

Functions

Multipoint lock with central lock and two additional locks, flat front plate, with pivoting bolt and spring latch

Online data sheet



Technical Features

Lock compatible with European profile cylinders, has burglar-proof pivoting bolts and a reversible spring latch (RH or LH).
 Bolts operated with the cylinder.
 Spring latch operated with the cylinder and with the 8 mm handle spindle.
 Cylinder handle C/C distance 85 mm.
 Bolts with thickness of 10 mm and minimum protrusion of 24 mm.
 Spring latch with 10 mm protrusion.

Materials

Lock cover plates and case plate in zinc plated steel
 Flat front in stainless steel
 Spring latch and bolts in nickel-plated steel
 Zinc plated steel cylinder fixing screw
 Lock fixing screws in stainless steel

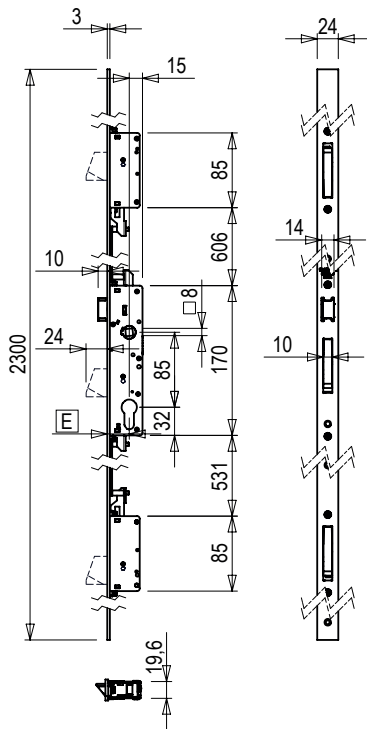

Item code	Description	Backset E [mm]	Front width [mm]	Compatible counterplates	Base Raw	Anodised Elox	Painted	Trend/Gold Brass	Pieces per pack
04854	MULTIPOINT LOCK WITH FLAT FRONT	30	24	04861 - 04862	X				1
04855	MULTIPOINT LOCK WITH FLAT FRONT	35	24	04861 - 04862	X				1

MULTIPOINT DOOR LOCKS U-SHAPED FRONT

**Functions**

Multipoint lock with central lock and additional locks, front "U" shaped plate, with pivoting bolt and spring latch.

Online data sheet

**Technical Features**

Lock compatible with European profile cylinders, has burglar-proof pivoting bolts and a reversible spring latch (RH or LH).

Bolts operated with the cylinder.

Spring latch operated with the cylinder and with the 8 mm handle spindle.

Cylinder handle C/C distance 85 mm.

Bolts with thickness of 10 mm and minimum protrusion of 24 mm.

Spring latch with 10 mm protrusion.

Materials

Lock cover plates and case plate in zinc plated steel

Stainless steel "U" front

Spring latch and bolts in nickel-plated steel

Zinc plated steel cylinder fixing screw

Lock fixing screws in stainless steel

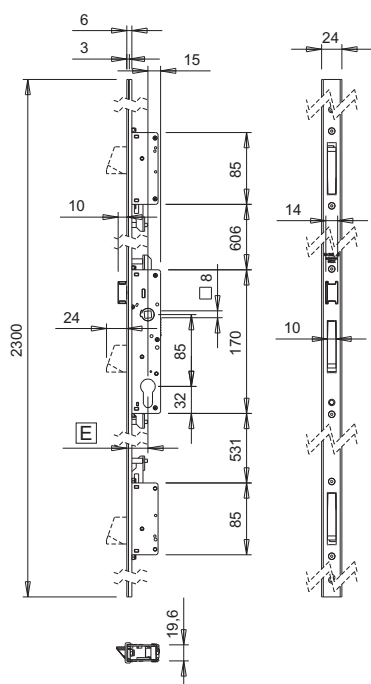

Item code	Description	Backset E [mm]	Front width [mm]	Compatible counterplates	Base Raw	Anodised Elox	Painted	Trend/Gold Brass	Pieces per pack
04850	MULTIPOINT LOCK WITH "U" FRONT	25	24	04861 - 04862	X				1
04851	MULTIPOINT LOCK WITH "U" FRONT	30	24	04861 - 04862	X				1
04852	MULTIPOINT LOCK WITH "U" FRONT	35	24	04861 - 04862	X				1

COUNTERPLATES



Functions

Counterplates to be combined with the central locks and multipoint locks per doors.

Online data sheet



Technical Features

Type 1 and 2

Adjustable stainless steel counterplates to be combined with the door locks. Front fixing in a channel with a cam system for coupling in the channel. Side adjustment ± 2 mm with the two adapters ready-assembled to the counterplate

Type 3, 4 and 5

Counterplates and set of flat counterplates to be combined with the single and multi-point locks.

Front fixing with self-tapping screws.

Side adjustment with slots.

Type 6 and 7

Counterplates and set of "U" shaped counterplates to be combined with the single and multi-point locks.

Front fixing with self-tapping screws.

Side adjustment with slots.

Type 8

Shim under the front to be used on profile cross-sections with a large stack to improve the grip of the spring latch of the lock on the counterplate.

Type 9

Flat counterplate to be combined with the locks with dead bolt and latch.

Front fixing with self-tapping screws.

Materials

Type 1 and 2

Front plate, cams and screws for fixing to the profile made of stainless steel

Adapters for side adjustment made of zamak

Type 3, 4 and 5

Counterplates and screws for fixing to the profile made of stainless steel

Type 6 and 7

Counterplates and screws for fixing to the profile made of stainless steel

Polyamide concealer caps

Type 8

Polyamide shim

Type 9

Counterplates and screws for fixing to the profile made of stainless steel

Counterplate Type 1

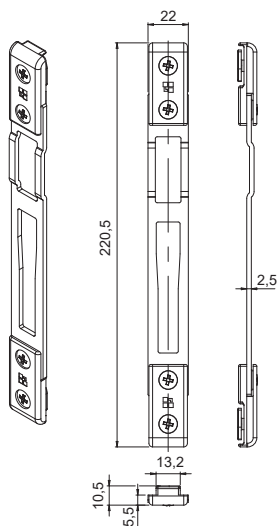

Counterplate Type 2

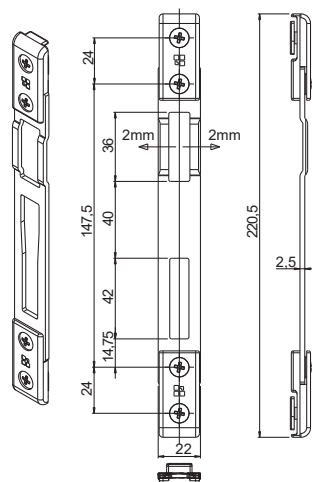

Counterplate Type 3

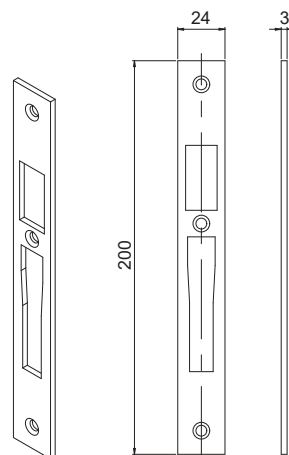

Counterplate Type 4

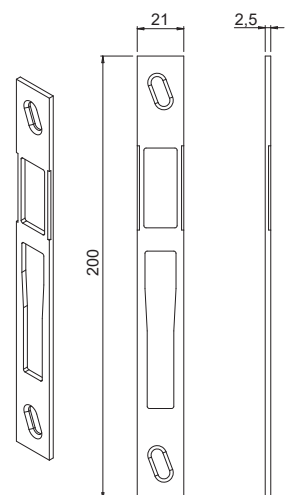

Counterplate Type 5

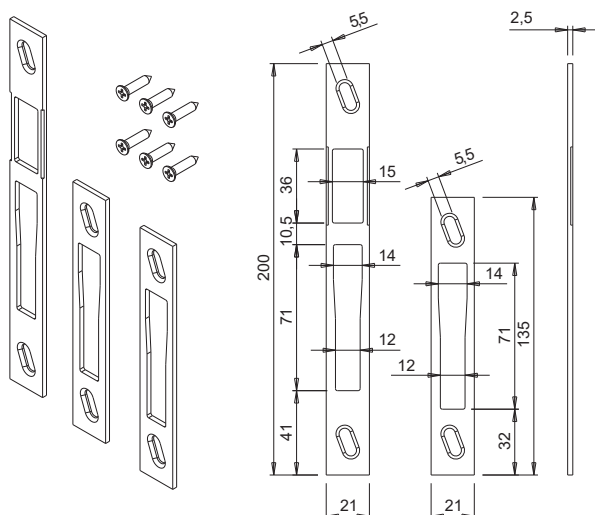

Counterplate Type 6

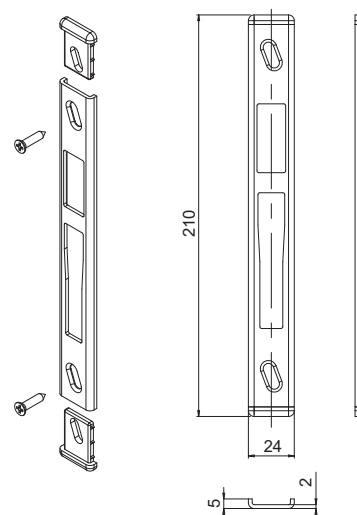

Counterplate Type 7

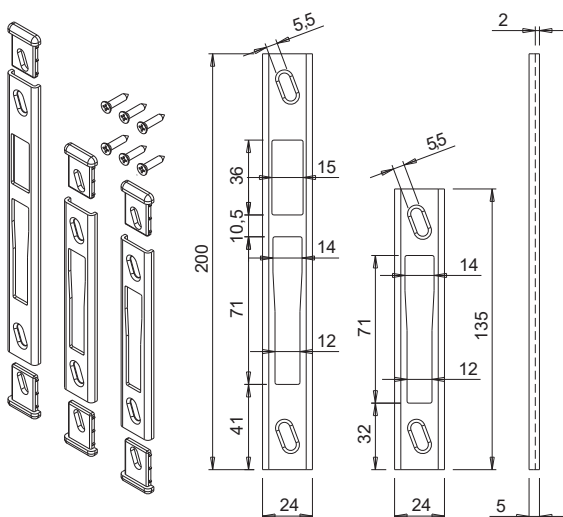

Counterplate Type 9

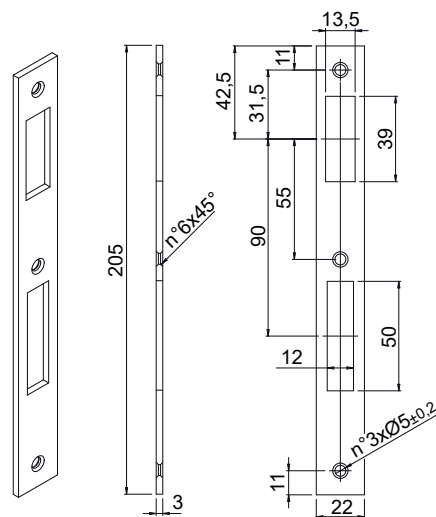

Adjustments

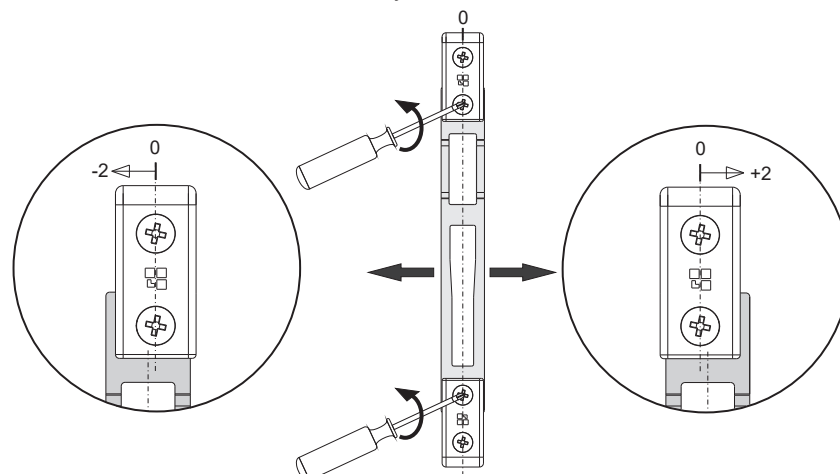

DOOR LOCKS

Item code	Descriptions	Note	Adjustment	Width [mm]	PROFILE CROSS - SECTION	Can be combined with lock	Base Raw	Anodised Elox	Painted	Trend/Gold Brass	Pieces per pack
04630	COUNTERPLATE FOR DOOR LOCKS	Type 1	± 2 mm	22	C001-C002- C004-C011- C012-C013-C014- C015-C016-C017	0462701 - 0462801 - 0461301 - 0461401 - 0461501 - 04616 04617 - 04618 - 0461901 - 0462001 - 0462101 - 04623 - 04624	X				5
04639	UNIVERSAL COUNTERPLATE	Type 3	-	24		0462701 - 0462801 - 0461301 - 0461401 - 0461501 - 04616 04617 - 04618 - 0461901 - 0462001 - 0462101 - 04623 - 04624	X				10
04655	COUNTERPLATE FOR LOCKS FOR PERIMETER LOCKING	Type 2	± 2 mm	22	C001-C016	04645 - 04646 - 04649 - 04650 - 04699	X				5
0465801	FLAT COUNTERPLATE	Type 9	-	22		0763001 - 0763101 - 0763201	X				10
04859	COUNTERPLATE W/ FLAT FRONT	Type 4	± 1.5 mm	21		0462701 - 0462801 - 0461301 - 0461401 - 0461501 - 04616 - 04617 - 04618 - 0461901 - 0462001 - 0462101 - 04623 - 04624	X				5
04860	COUNTERPLATE W/ U FRONT	Type 6	± 1.5 mm	24		0462701 - 0462801 - 0461301 - 0461401 - 0461501 - 04616 - 04617 - 04618 - 0461901 - 0462001 - 0462101 - 04623 - 04624	X				5
04861	FLAT FRONT COUNTERPLATE KIT	Type 5	± 1.5 mm	21	C001	04850 - 04851 - 04852 - 04853 - 04854 - 04855	X				5
04862	U FRONT COUNTERPLATE KIT	Type 7	± 1.5 mm	24	C001	04850 - 04851 - 04852 - 04853 - 04854 - 04855	X				5

EUROPEAN PROFILE DOUBLE CYLINDER

**Functions**

Double cylinder with European profile

Online data sheet

**Technical Features**

Double cylinder with European profile with 5-pin coding system.

Projecting DIN cam.

Stack 0.5 mm.

The product is supplied with a set of 3 keys in a ring and countersunk flat head fixing screw.

Materials

Cylinder body in nickel-plated brass

Nickel-plated brass cylinder

DIN cam in sintered steel

Pins and counter-pins in brass

Springs in stainless steel

Nickel-plated brass key

Zinc plated steel fixing screw

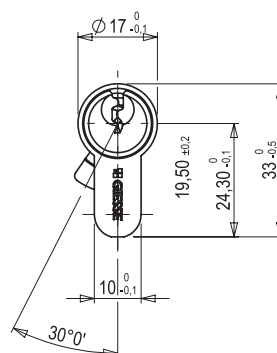
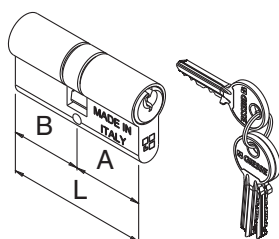

DOOR CYLINDERS

Item code	Description	L [mm]	A [mm]	B [mm]	Base Raw	Anodised Elox	Painted	Trend/Gold Brass	Pieces per pack
04469N	Double cylinder with European profile 35/35	70	35	35	X				10
04470N	Double cylinder with European profile 40/40	80	40	40	X				10
04471N	Double cylinder with European profile 35/45	80	35	45	X				10
04472N	Double cylinder with European profile 35/55	90	35	55	X				10
04473N	Double cylinder with European profile 30/70	100	30	70	X				10
04474N	Double cylinder with European profile 40/60	100	40	60	X				10
04490N	Double cylinder with European profile 30/30	60	30	30	X				10
04491N	Double cylinder with European profile 30/40	70	30	40	X				10
04492N	Double cylinder with European profile 30/45	75	30	45	X				10
04493N	Double cylinder with European profile 35/40	75	35	40	X				10
04494N	Double cylinder with European profile 30/50	80	30	50	X				10
04495N	Double cylinder with European profile 40/50	90	40	50	X				10
04652N	Double cylinder with European profile 30/55	85	30	55	X				10
04653N	Double cylinder with European profile 30/60	90	30	60	X				10
04654N	Double cylinder with European profile 30/65	95	30	65	X				10
05988	Cilindro doble de perfil europeo 30/75	105	30	75	X				10
05999	Double cylinder with European profile 96/48	96	48	48	X				10
07675	Double cylinder with European profile 27/27	54	27	27	X				10
07680	Double cylinder with European profile 31/31	62	31	31	X				10
07681	Double cylinder with European profile 27/37	64	27	37	X				10
07682	Double cylinder with European profile 35/35	70	35	35	X				10
07683	Double cylinder with European profile 31/41	72	31	41	X				10
07684	Double cylinder with European profile 41/41	82	41	41	X				10
07685	Double cylinder with European profile 31/51	82	31	51	X				10
07687	Double cylinder with European profile 31/61	92	31	61	X				10
07688	Double cylinder with European profile 51/41	92	51	41	X				10
07689	Double cylinder with European profile 31/91	122	31	91	X				10
07697	Double cylinder with European profile 55/55	110	55	55	X				10
07698	Double cylinder with European profile 37/37	74	37	37	X				10
07699	Double cylinder with European profile 37/47	84	37	47	X				10

HALF CYLINDER EUROPEAN PROFILE



Functions
Half cylinder with European profile

Online data sheet



Technical Features

European profile half cylinder with 5-pin coding system.
Projecting DIN cam.
Stack 0.5 mm.
The product is supplied with a set of 3 keys in a ring and countersunk flat head fixing screw.

Materials

Cylinder body in nickel-plated brass
Nickel-plated brass cylinder
DIN cam in sintered steel
Pins and counter-pins in brass
Springs in stainless steel
Nickel-plated brass key
Zinc plated steel fixing screw

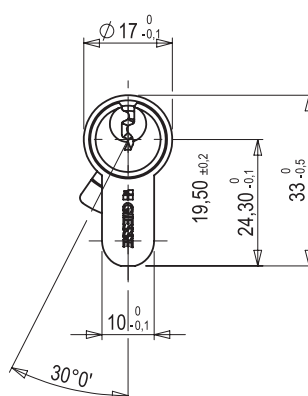
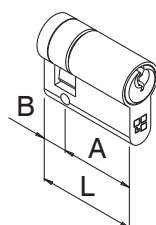

Item code	Description	L [mm]	A [mm]	B [mm]	Base Raw	Anodised Elox	Painted	Trend/Gold Brass	Pieces per pack
04496N	Half cylinder with European profile 30/10	40	30	10	X				10
04497N	Half cylinder with European profile 35/10	45	35	10	X				10
04498N	Half cylinder with European profile 40/10	50	40	10	X				10
04499N	Half cylinder with European profile 50/10	60	50	10	X				10
04500N	Half cylinder with European profile 60/10	70	60	10	X				10
05995	Half cylinder with European profile 45/10	55	45	10	X				10
07674	Half cylinder with European profile 27/10	37	27	10	X				10
07686	Half cylinder with European profile 31/10	41	31	10	X				10
07696	Half cylinder with European profile 61/10	71	61	10	X				10

EUROPEAN PROFILE CYLINDER WITH KNOB



Functions

European profile cylinder with knob.

Online data sheet



Technical Features

European profile cylinder with knob with 5-pin coding system.
 Projecting DIN cam.
 Stack 0.5 mm.
 The product is supplied with a set of 3 keys in a ring and countersunk flat head fixing screw.

Materials

Cylinder body in nickel-plated brass
 Nickel-plated brass cylinder
 DIN cam in sintered steel
 Pins and counter-pins in brass
 Springs in stainless steel
 Nickel-plated brass key
 Nickel-plated brass knob
 Zinc plated steel fixing screw

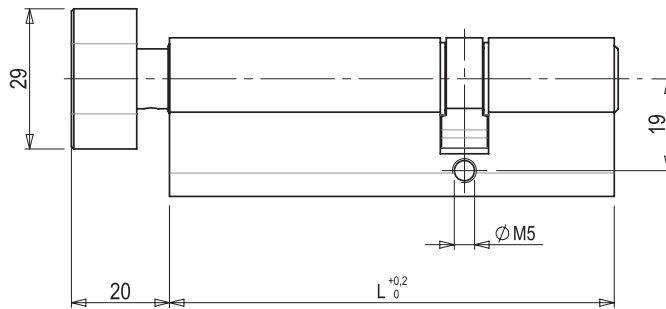
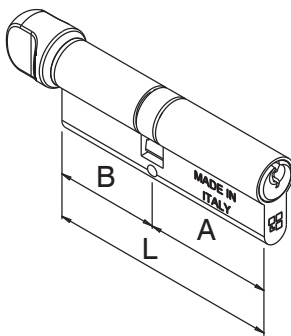

Knob type 1

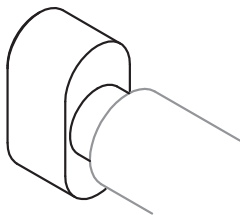

Knob type 2

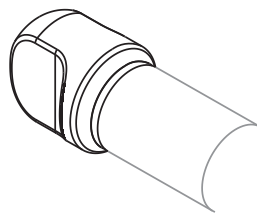

Knob type 3

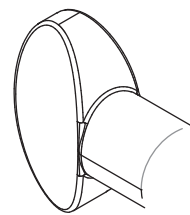

DOOR CYLINDERS

Item code	Description	L [mm]	A [mm]	B (knob side) [mm]	Knob type	Base Raw	Anodised Elox	Painted	Trend/Gold Brass	Pieces per pack
04462N	European profile cylinder with knob 40/30	70	40	30	1	X				10
04463N	European profile cylinder with knob 35/35	70	35	35	1	X				10
04464N	European profile cylinder with knob 30/40	70	30	40	1	X				10
04465N	European profile cylinder with knob 50/30	80	50	30	1	X				10
04466N	European profile cylinder with knob 40/40	80	40	40	1	X				10
04467N	European profile cylinder with knob 60/30	90	60	30	1	X				8
04607N	European profile cylinder with knob 30/30	60	30	30	1	X				10
04633	European profile cylinder with knob 51/41	92	51	41	2	X				10
04634	European profile cylinder with knob 30/30	62	31	31	2	X				10
04636	European profile cylinder with knob 30/30	92	31	61	2	X				10
04647	European profile cylinder with knob 30/30	92	61	31	3	X				10
04665N	European profile cylinder with knob 30/60	90	30	60	1	X				8
05980	European profile cylinder with knob 30/45	75	30	45	1	X				10
05982	European profile cylinder with knob 55/30	85	55	30	1	X				10
05983	European profile cylinder with knob 30/55	85	30	55	1	X				10
05984	European profile cylinder with knob 35/60	95	35	60	1	X				10
05985	European profile cylinder with knob 70/30	100	70	30	1	X				10
05986	European profile cylinder with knob 65/45	110	65	45	1	X				10
05987	European profile cylinder with knob 30/65	95	30	65	1	X				10
05989	European profile cylinder with knob 65/30	95	65	30	1	X				10
05993	European profile cylinder with knob 30/70	100	30	70	1	X				10
05997	European profile cylinder with knob 30/75	100	30	75	1	X				10
05998	European profile cylinder with knob 75/30	100	75	30	1	X				10
07678	European profile cylinder with knob 30/30	122	31	91	2	X				10
07679	European profile cylinder with knob 30/30	122	91	31	2	X				10

HALF CYLINDER WITH KNOB



Functions

European profile half cylinder with knob.

Online data sheet



Technical Features

European profile half cylinder with knob with 5-pin coding system.
 Projecting DIN cam.
 Stack 0.5 mm.
 The product is supplied with a set of 3 keys in a ring and countersunk flat head fixing screw.

Materials

Cylinder body in nickel-plated brass
 Nickel-plated brass cylinder
 DIN cam in sintered steel
 Pins and counter-pins in brass
 Springs in stainless steel
 Nickel-plated brass knob
 Zinc plated steel fixing screw

Knob type 1

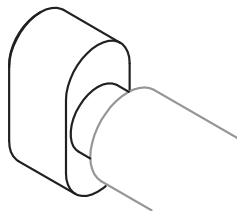

Knob type 1 overall dimensions

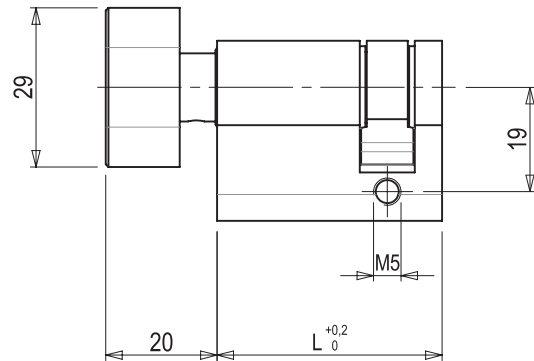

Knob type 2

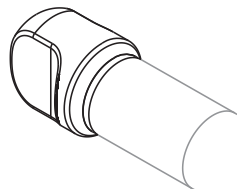

Knob type 2 overall dimensions

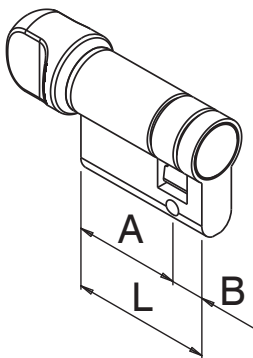
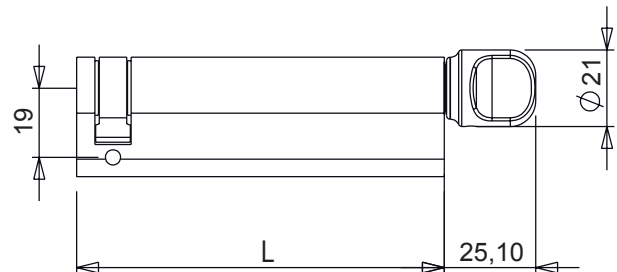

DOOR CYLINDERS

Item code	Description	L [mm]	A (knob side) [mm]	B [mm]	Knob type	Base Raw	Anodised Elox	Painted	Trend/Gold Brass	Pieces per pack
04635	Half cylinder with knob 31/10	41	31	10	2	X				10
04638	Half cylinder with knob 61/10	71	61	10	2	X				10
04666N	Half cylinder with knob 50/10	60	50	10	1	X				10
04667N	Half cylinder with knob 60/10	70	60	10	1	X				1
05990	Half cylinder with knob 40/10	50	40	10	1	X				10
05991	Half cylinder with knob 45/10	55	45	10	1	X				10
05992	Half cylinder with knob 55/10	65	55	10	1	X				10
07676	Half cylinder with knob 71/10	81	71	10	2	X				10



BRASS WINDOW HANDLES

Functions

Reversible window handle for operating the M90 two-way and M180 one-way mechanisms on side-hung and tilt-and-turn windows.

Online data sheet



Technical Features

It is equipped with a positioner for stopping the rotation at 90° and 180° and has a square pin, for the transmission of the movement, size 7 mm with a stand-out of 40 mm.

The pull handle is hot forged, starting from a brass bar, with particular care that makes for excellent results.

The processes of cleaning, polishing and burnishing enhance the aesthetic characteristics of the brass, while the subsequent transparent, high-resistance painting ensures its durability.

Materials

Handle, cover and rotor in brass

Square spindle and plate in zinc plated steel

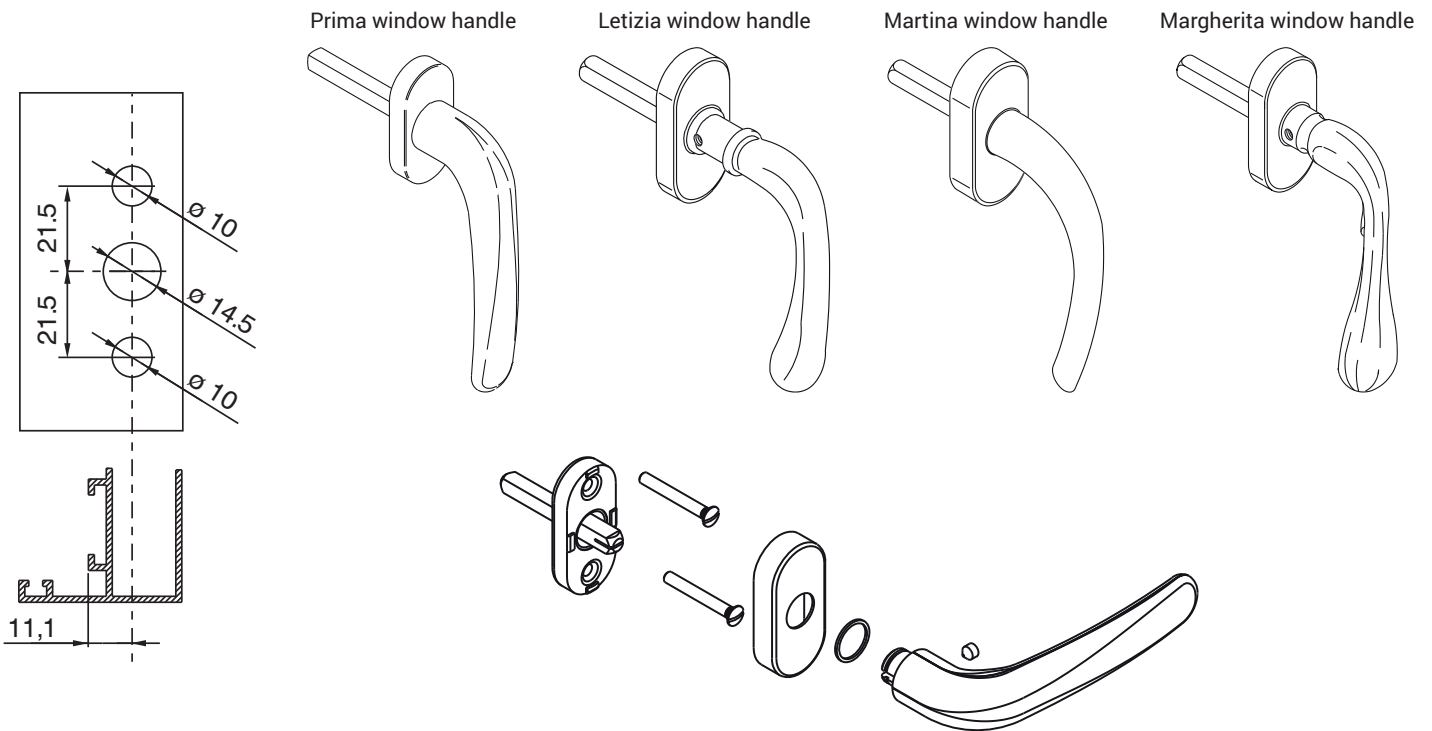

Item code	Description	PROFILE CROSS - SECTION	Note	Base Raw	Anodised Elox	Painted	Trend/Gold Brass	Pieces per pack
02481N	PRIMA WINDOW HANDLE	C001-C002-C007-C017-P002-P006-P007	square pin 7x40 mm				X	4
02482N	PRIMA WINDOW HANDLE	C001-C002-C007-C017-P002-P006-P007	square pin 7x70 mm				X	4
02483	TREND WINDOW HANDLE	-	EVODESIGN				X	5
02522N	MARTINA WINDOW HANDLE	C001-C002-C007-C017-P002-P006-P007					X	4
02542N	MARGHERITA WINDOW HANDLE	C001-C002-C007-C017-P002-P006-P007					X	4
02560N	LETIZIA WINDOW HANDLE	C001-C002-C007-C017-P002-P006-P007					X	4

BRASS HANDLES



Functions

Pair of handles, with stop device, reversible, for fitting on the upright or centre rail of the door.

Online data sheet



Technical Features

To guarantee the horizontal position of the handle, the pull handle is equipped with a return coil spring. The plate cover is screwed onto the plate, while final tightening is done with an Allen screw on the handle that packs everything together. The pull handle is hot forged, starting from a brass bar, with particular care that makes for excellent results. The processes of cleaning, polishing and burnishing enhance the aesthetic characteristics of the brass, while the subsequent transparent, high-resistance painting ensures its durability.

Materials

Handle and case cover in brass
Spring in harmonic steel
Square spindle, screws and Allen screw in zinc plated steel

Round rosette
Prima handle

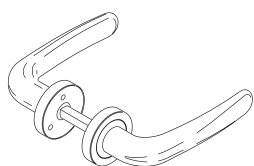

Oval rosette
Prima handle

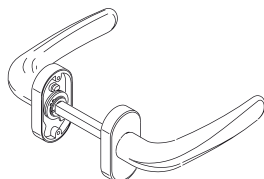

Oval rosette
Marina handle

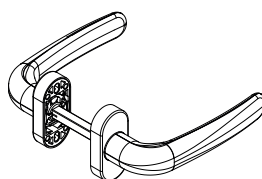

Golf knob

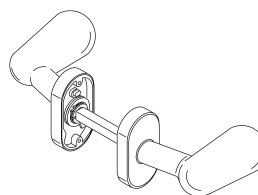

Oval rosette
Simona handle

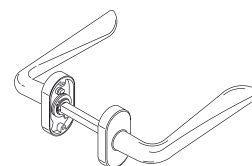

Oval rosette
Martina handle

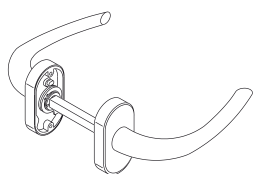

Oval rosette
Margherita handle

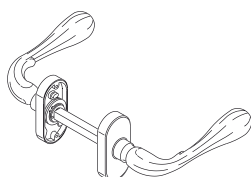

Oval rosette
Alba handle

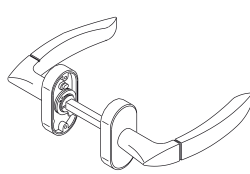

Round rosette
Letizia handle

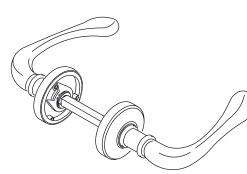

Oval rosette
Letizia handle

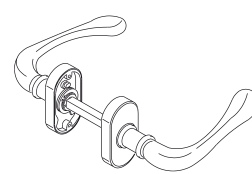

Machining type 1

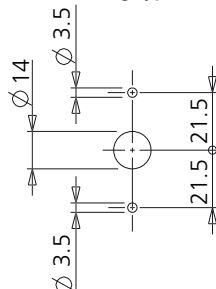

Machining type 2

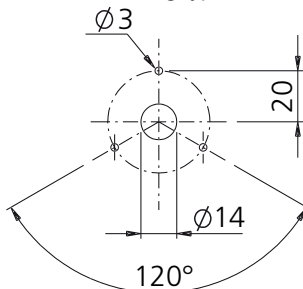

Machining type 3

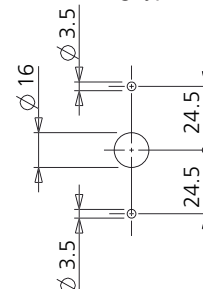

EVO DESIGN

Item code	Description	Machining	Base Raw	Anodised Elox	Painted	Trend/Gold Brass	Pieces per pack
02473N	OVAL ROSETTE BRASS PRIMA HANDLE-CP	3				X	2
02474N	ROUND ROSETTE BRASS PRIMA HANDLE-CP	2				X	2
02487	OVAL ROSETTE TREND HANDLE	1				X	5
02505	BRASS GOLF KNOB-CP	3				X	2
02518N	BRASS SIMONA HANDLE-CP	3				X	2
02521N	OVAL ROSETTE BRASS MARTINA HANDLE-CP	3				X	2
02541N	OVAL ROSETTE BRASS MARGHERITA HANDLE-CP	3				X	2
02553N	OVAL ROSETTE BRASS ALBA HANDLE-CP	3				X	2
02558N	ROUND ROSETTE BRASS LETIZIA HANDLE-CP	2				X	2
02559N	OVAL ROSETTE BRASS LETIZIA HANDLE-CP	3				X	2



BRASS PLATES

Functions

Round cylinder cover plates in brass for European profile cylinder and Patent cylinder.

Online data sheet



Art. 02543

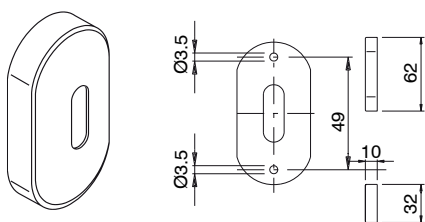

Art. 02544

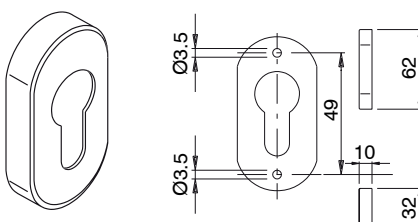

Art. 02545

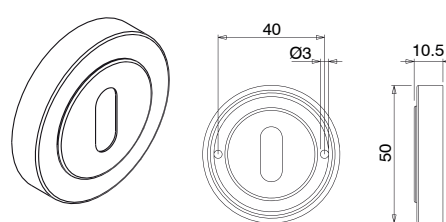

Art. 02546

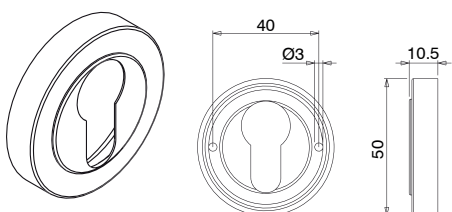

Art. 02547

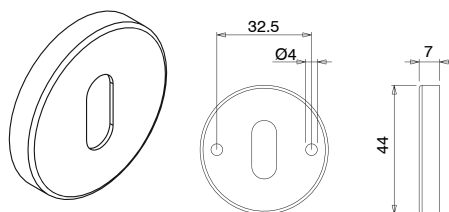

Art. 02548

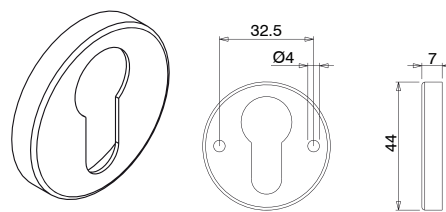

Item code	Description	Materials	Base Raw	Anodised Elox	Painted	Trend/Gold Brass	Pieces per pack
02543	BRASS OVAL ROSETTE-CP	Polyamide plate and brass cover				X	10
02544	BRASS OVAL ROSETTE-CP	Polyamide plate and brass cover	X			X	10
02545	BRASS ROUND ROSETTE-CP	Brass plate and cover				X	10
02546	BRASS ROUND ROSETTE-CP	Brass plate and cover				X	10
02547	BRASS ROUND ROSETTE-CP	Polyamide plate and brass cover				X	10
02548	BRASS ROUND ROSETTE-CP	Polyamide plate and brass cover				X	10

UNICA SYSTEM

Functions

Complete system of mechanisms for operating inward and outward opening casement windows, shutters, tilt-and-turn, sliding and top-hung windows.

Technical Features

The system features a mechanism supplied without internal components. Based on the requirements, using the completion kit, it becomes a one-way or two-way Cremona.

The kit, in its turn, can be completed with locking elements.

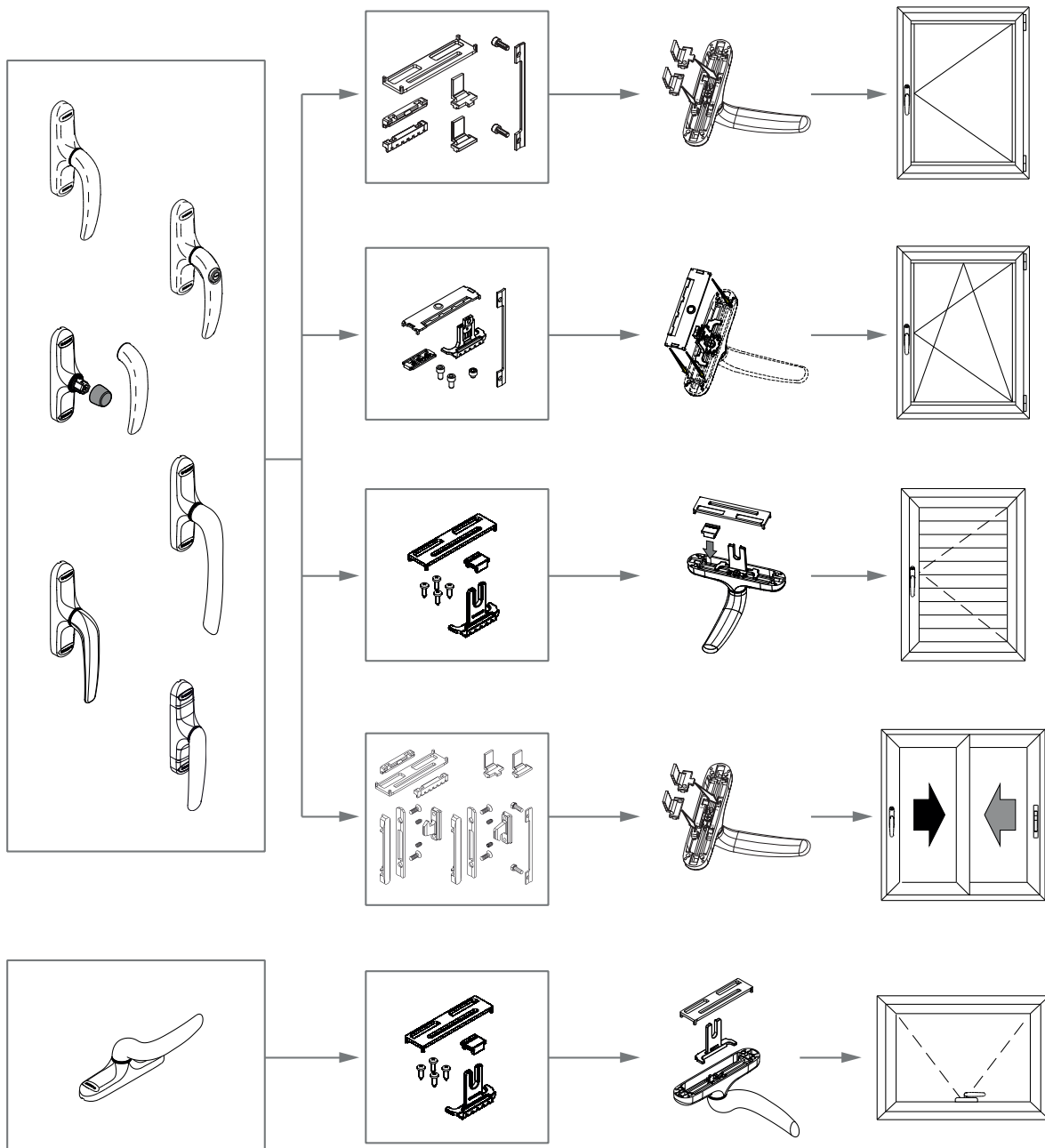
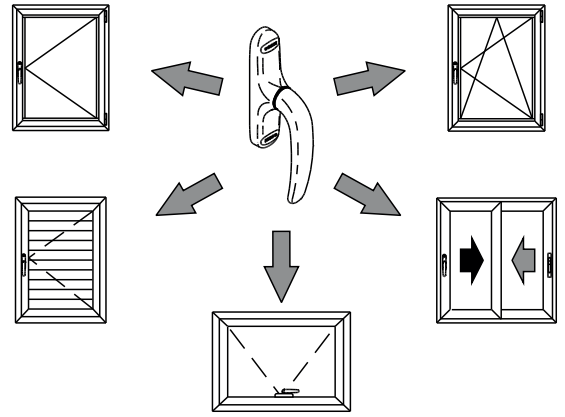

UNICA SYSTEM CREMONE



Functions

Cremone with no internal components. Depending on need, it can be transformed into a Cremone for inward opening, outward opening casement or tilt-and-turn by using the specific kits (also supplied complete with the lock points).

Online data sheet



Technical Features

The UNICA cremone mechanism is available in different versions and is supplied without the internal parts. The procedure for mounting them, contained in the customization kit, is for the window maker, but is quick and straightforward.

All Unica cremones have a fixing C/C distance of 104 mm.

Materials

- Handle in die-cast aluminium
- Cases and gear in die-cast zamak
- Steel spring
- Zinc plated steel screw
- Shim in Hostaform

Example of mounting the tilt-and-turn window Cremone (01150N+04071N)

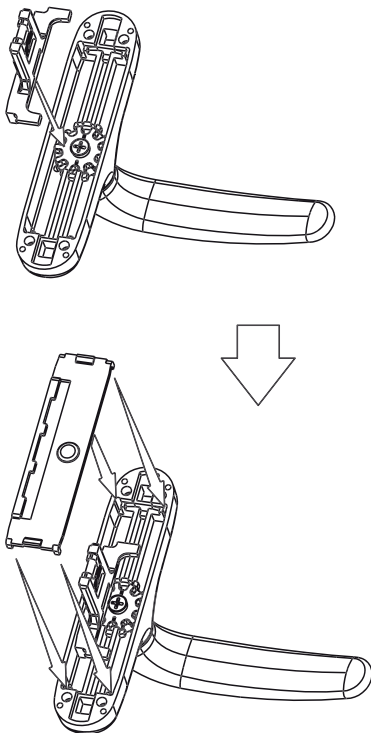

Example of mounting the Apex Cremone (01150N+02259)

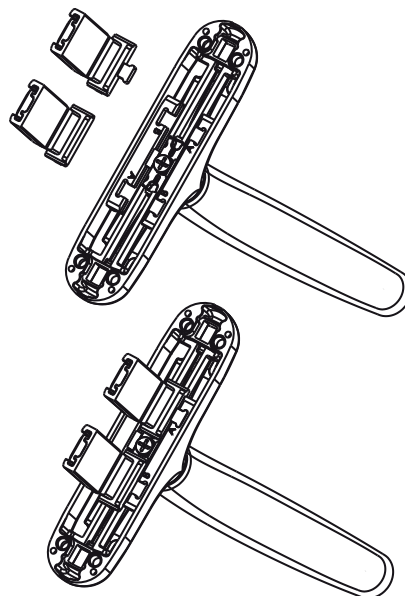

C/C distance machining 104 mm

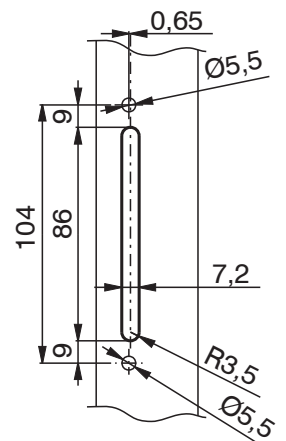

00963

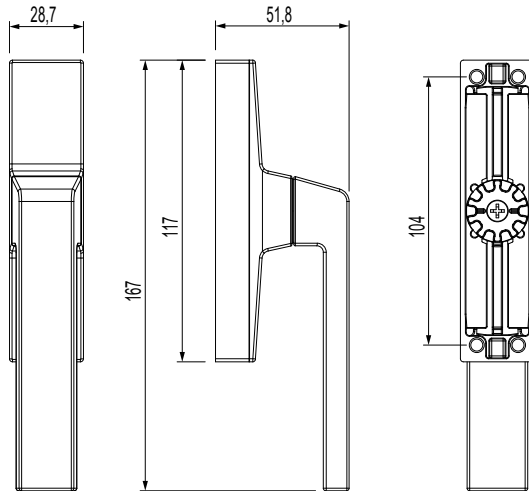
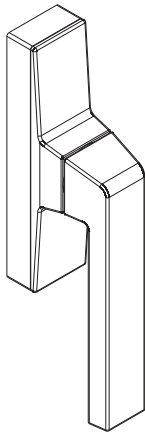

00966

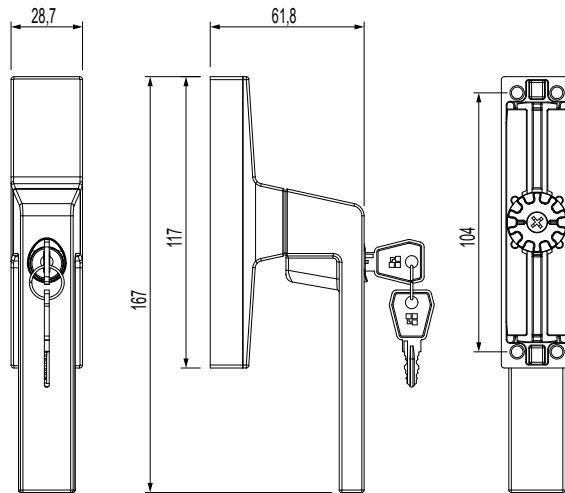
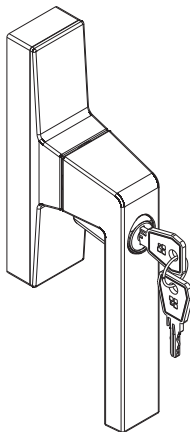

01063

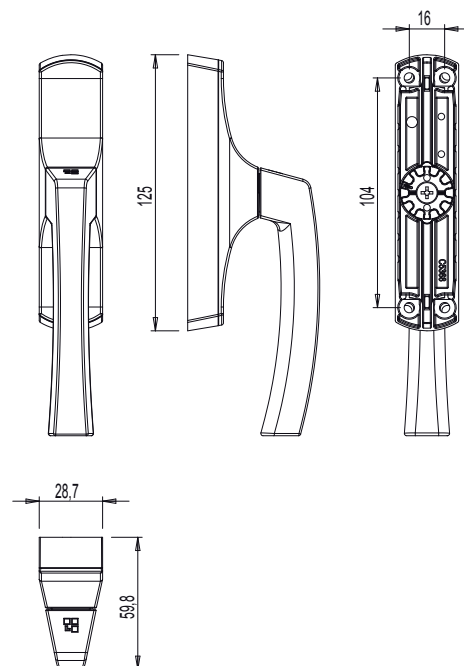
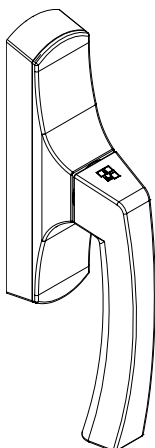

01125

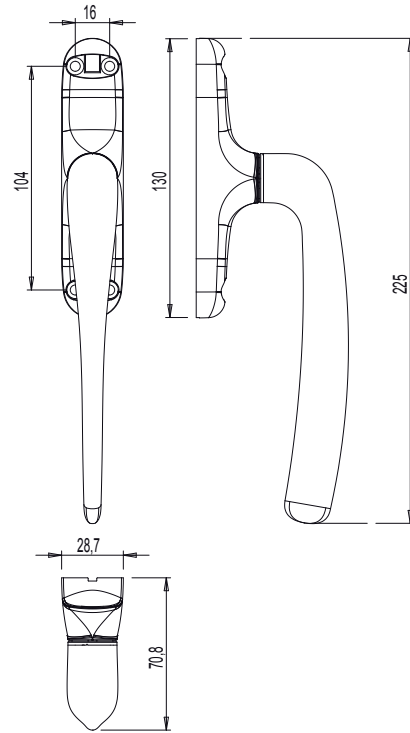
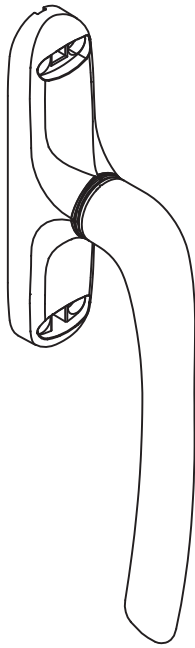

01126

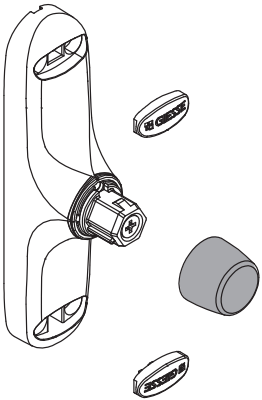

01129

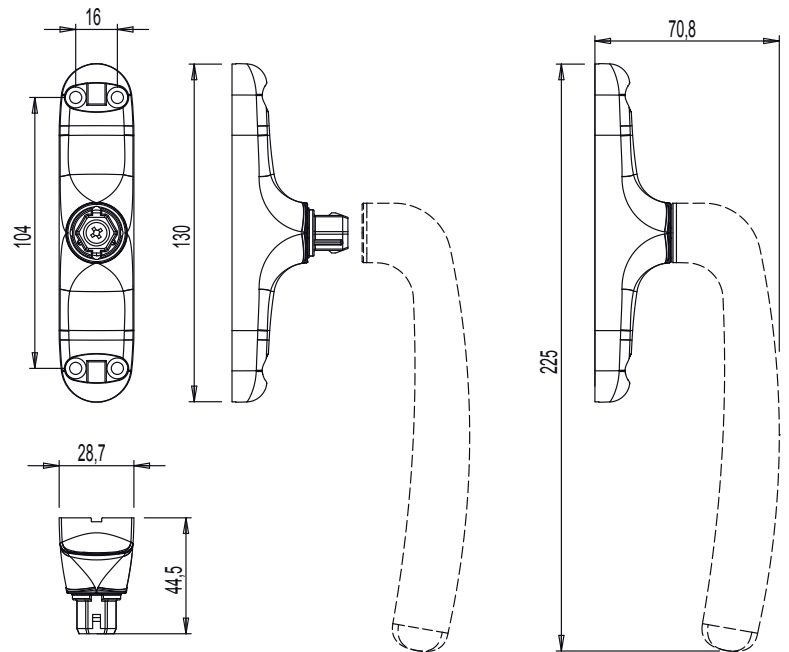
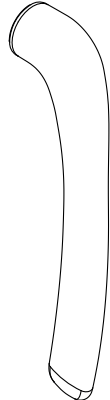

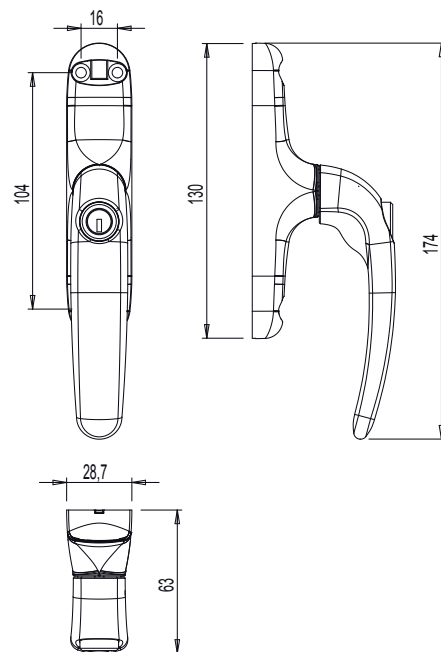
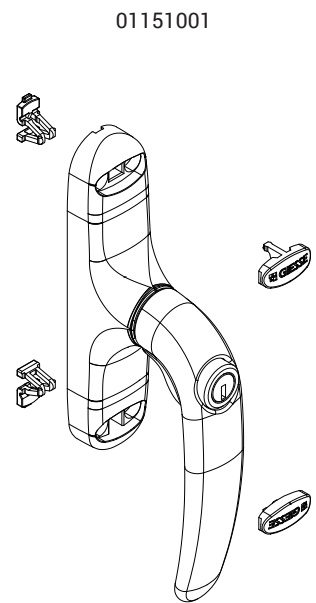
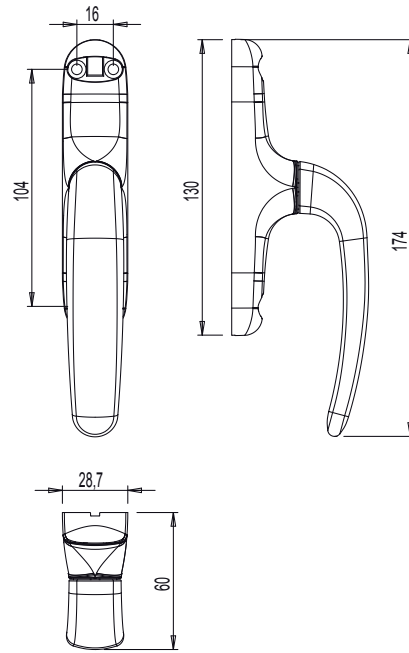
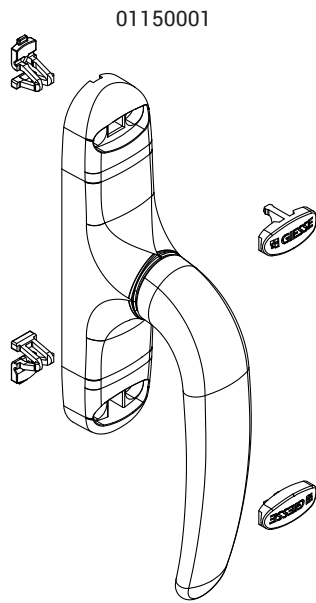

011691

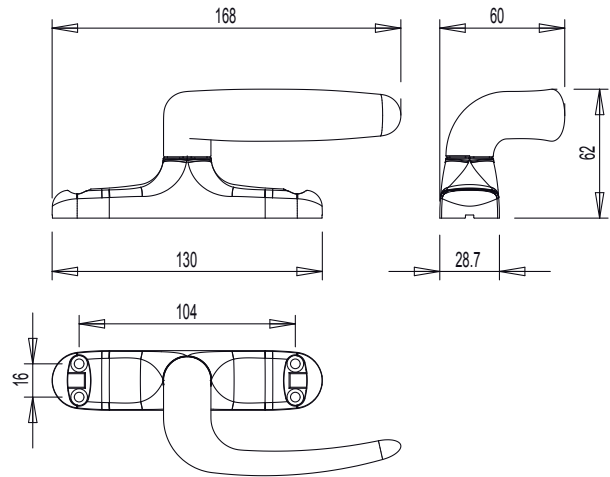
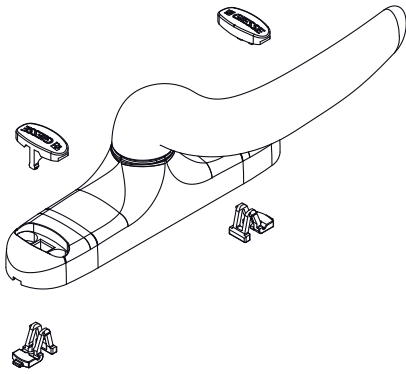

011692

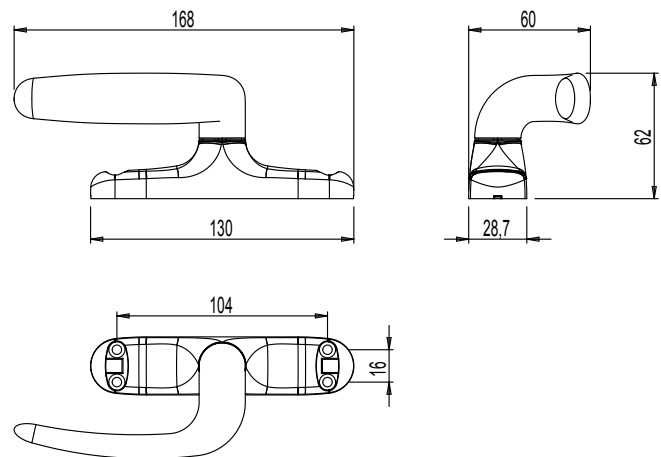
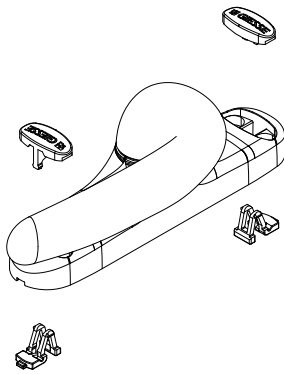

01230

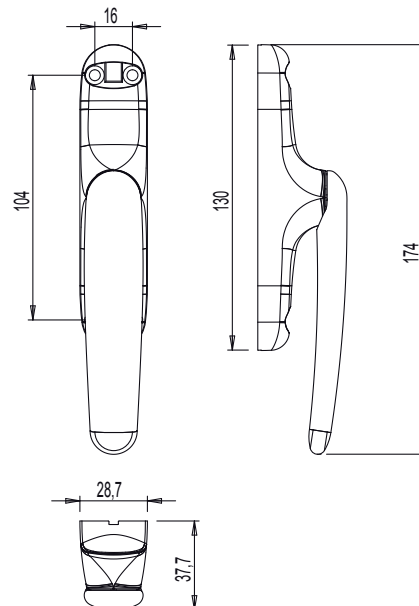

UNICA SYSTEM

Item code	Description	PROFILE CROSS - SECTION	Hand	C/C distances	Base Raw	Anodised Elox	Painted	Trend/Gold Brass	Pieces per pack
00963	KORA 0-180 UNICA SYSTEM CREMONE	C001-C002-C003-C004-C005-C006-C007-C008-C009-C010-C012-C013-C014-C015-C016-C017		104 mm	X		X		10
00966	KORA KEY 0-180 UNICA SYSTEM CREMONE	C001-C002-C003-C004-C005-C006-C007-C008-C009-C010-C012-C013-C014-C015-C016-C017		104 mm	X		X		5
01063	ASIA OUTWARD 0-180° CREMONE	C001-C007-P002		104 mm	X		X		10
01125001	UNICA SYS. CREMONE PULL HANDLE L=172	C001-C002-C003-C004-C005-C006-C007-C008-C009-C010-C012-C013-C014-C015-C016-C017-P001-P002-P004-P005-P006-P007-P008-P009-P010		104 mm			X		10
01126	UNICA AWAY CREMONE	C001-C002-C003-C004-C005-C006-C007-C008-C009-C010-C012-C013-C014-C015-C016-C017-P001-P002-P004-P005-P006-P007-P008-P009-P010		104 mm			X		10
01129	PULL HANDLE FOR UNICA - AWAY	C001-C002-C003-C004-C005-C006-C007-C008-C009-C010-C012-C013-C014-C015-C016-C017-P001-P002-P004-P005-P006-P007-P008-P009-P010		-			X		10
01150001	UNICA SYSTEM CREMONE	C001-C002-C003-C004-C005-C006-C007-C008-C009-C010-C012-C013-C014-C015-C016-C017-P001-P002-P004-P005-P006-P007-P008-P009-P010		104 mm	X		X	X	10
01151001	UNICA KEY CREMONE	C001-C002-C003-C004-C005-C006-C007-C008-C009-C010-C012-C013-C014-C015-C016-C017-P001-P002-P004-P005-P006-P007-P008-P009-P010		104 mm	X		X	X	10
011691	UNICA OFFSET HANDLE CW2 CREMONE	-	Right	104 mm	X		X		5
011692	UNICA OFFSET HANDLE CW2 CREMONE	-	Left	104 mm	X		X		5
01230	UNICA CREMONE LOWERED HANDLE	C001-C002-C003-C004-C005-C006-C007-C008-C009-C010-C012-C013-C014-C015-C016-C017-P001-P002-P004-P005-P006-P007-P008-P009-P010		104 mm	X		X	X	5

UNICA SYSTEM CREMONE KIT

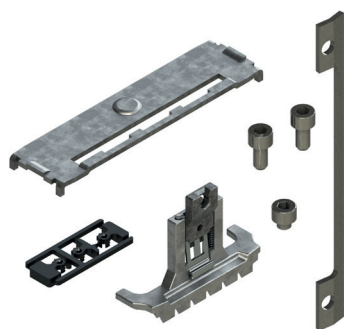

Functions

Components that, added to the Unica Cremone without internal components, enable converting them into the finished product.

Online data sheet



Technical Features

Completion kit that, in combination with the Unica mechanism, enables creating a finished cremone (sash, tilt-and-turn window, etc.). Composed of the internal components and any fixing components (screws and plate), it must be suitably mounted by the window maker.

After the assembly phase the cremone is ready to be installed.

The method of assembly of the kit is adequately explained in the fitting instructions.

Materials

Black polyamide plate (zinc plated steel for tilt-and-turn window version)

Sliders and Racks in zinc plated die-cast zamak
Stainless steel screws and fixing plate

Art. 02259

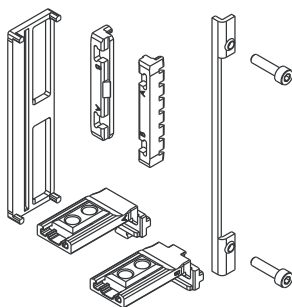

Art. 02403

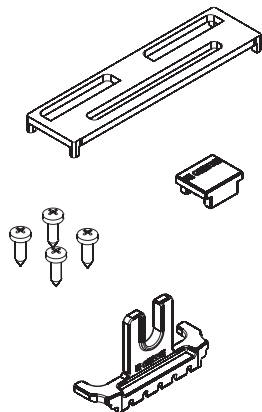

Art. 02407

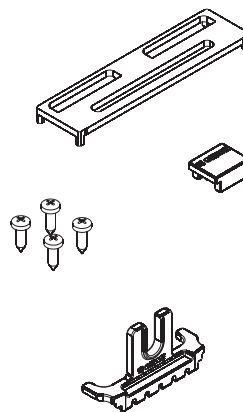

Art. 02408

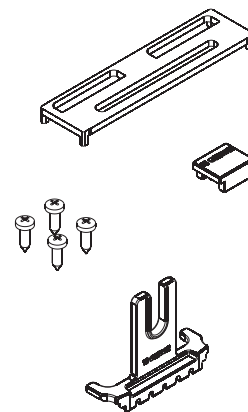

Art. 04071N

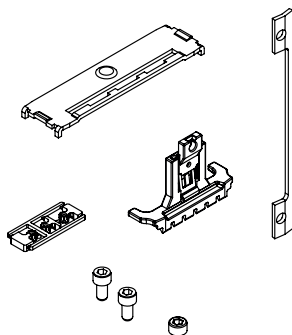

Art. 04080

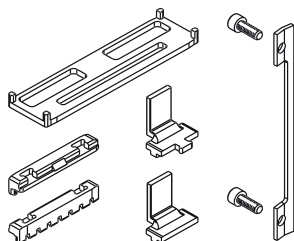

UNICA SYSTEM

Item code	Description	PROFILE CROSS - SECTION	Type	Can be combined with	Operation	Pull handle 0°	Pull handle 90°	Pull handle 180°	Base Raw	Anodised Elox	Painted	Trend/Gold Brass	Pieces per pack
02259	APEX KIT FOR UNICA CREMONE	-	Outward Opening	01063 - 01125 - 01126 - 01150N - 01151N	Two-way	closed	open		X				20
02403	KIT FOR OUT. OPENING UNICA SYSTEM SLIDER 28	-	Outward Opening	01063 - 01125 - 01126 - 01150N - 01151N - 011691 - 011692	One-way	closed	open		X				50
02407	KIT FOR OUT. OPENING UNICA SYSTEM SLIDER 20	-	Outward Opening	01063 - 01125 - 01126 - 01150N - 01151N - 011691 - 011692	One-way	closed	open		X				50
02408	KIT FOR OUT. OPENING UNICA SYSTEM SLIDER 35	C001-C003-C016	Outward Opening	01063 - 01125 - 01126 - 01150N - 01151N - 011691 - 011692	One-way	closed	open		X				50
04071N	UNICA SYSTEM TILT-AND-TURN WINDOW KIT	C001-C002-C003-C004-C005-C006-C007-C008-C009-C010-C012-C013-C014-C015-C016-C017	Tilt-and-turn window	01063 - 01125 - 01126 - 01150N - 01151N	One-way	closed	open	bottom-hung windows	X				50
04080	KIT FOR IN. OPENING UNICA SYSTEM	C001-C002-C003-C004-C005-C006-C007-C008-C009-C010-C012-C013-C014-C015-C016-C017-P001-P002-P003-P004-P005-P006-P007-P008-P009-P010	Sash	01063 - 01125 - 01126 - 01150N - 01151N	Two-way	closed	open		X				50

UNICA SYSTEM OUTWARD OPENING KIT



Functions

Kit to be combined with the UNICA and UNICA KEY cremones, composed of all the elements necessary to make the fastening mechanism of an outward-opening casement.

Online data sheet



Technical Features

Using this kit allows you to convert the UNICA cremone mechanism into a cremone for outward opening casements. Composed of the elements inside the Cremone (rack, sliders and plate) to be assembled easily by hand, all completed by the Outward Opening mechanism and in some cases by the fastening mechanisms (strikers and terminals).

Materials

Black polyamide plate
Sliders and racks in zinc plated zamak
Zinc plated steel screws
Mechanism in extruded aluminium
Connecting block in black polyamide

Art. 02237

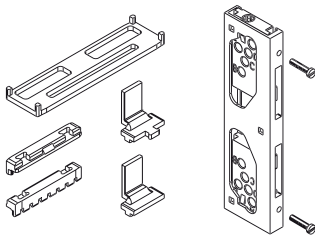

Art. 02238

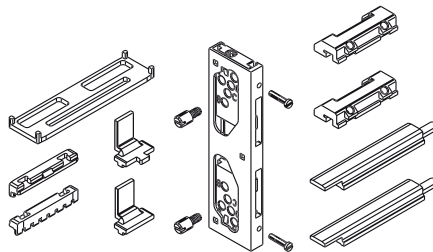

Art. 02240

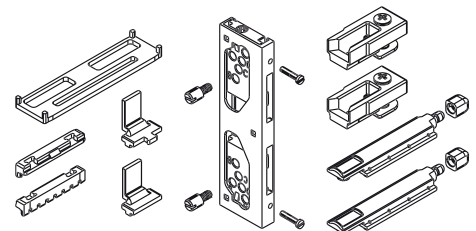

Art. 02241

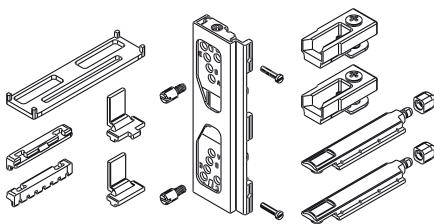

Art. 02243

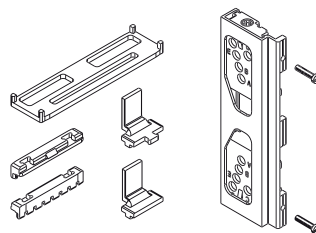

Art. 02244

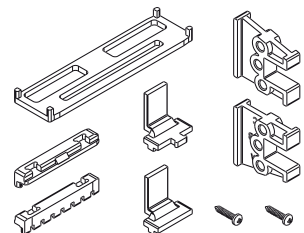

Machining type 1

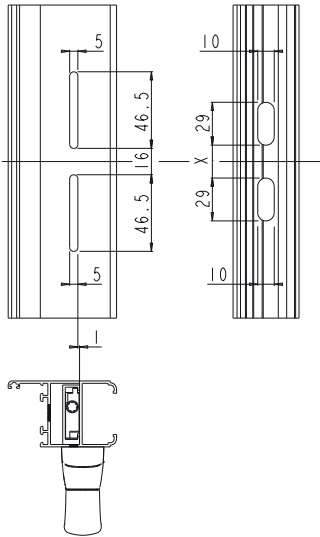

Machining type 2

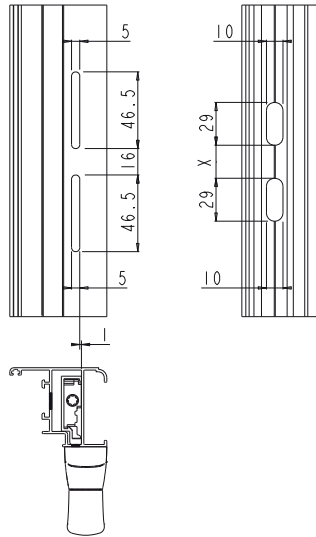

Machining type 3

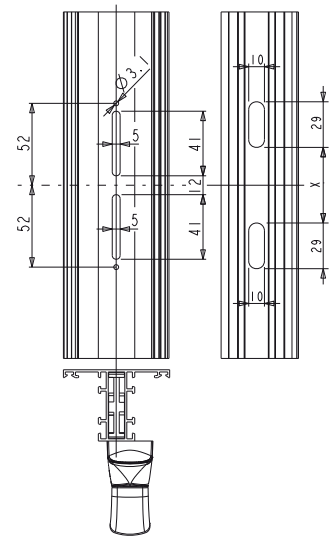

Type 1

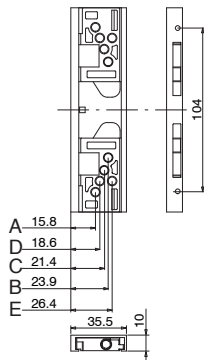

Type 2

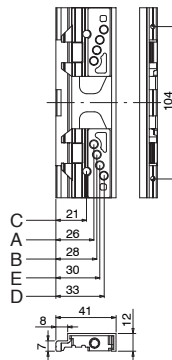

Type 3

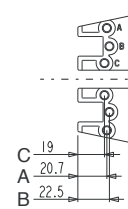

Item code	Description	Type	Can be combined with	Machinings	Operation	Pull handle 0°	Pull handle 90°	Base Raw	Anodised Elox	Painted	Trend/Gold Brass	Pieces per pack
02237	KIT FOR OUTWARD OPENING UNICA SYSTEM	Outward Opening	01063 - 01150N - 01151N - 01126	1	Two-way	closed	open	X				50
02240	KIT FOR OUTWARD OPENING UNICA SYSTEM	Outward Opening	01063 - 01150N - 01151N - 01126	1	Two-way	closed	open	X				50
02241	KIT FOR OUTWARD OPENING UNICA SYSTEM	Outward Opening	01063 - 01150N - 01151N - 01126	2	Two-way	closed	open	X				50
02243	KIT FOR OUTWARD OPENING UNICA SYSTEM	Outward Opening	01063 - 01150N - 01151N - 01126	2	Two-way	closed	open	X				50
02245	KIT FOR OUTWARD OPENING UNICA SYSTEM	Outward Opening	01063 - 01150N - 01151N - 01126		Two-way	closed	open	X				20
02246	KIT FOR OUTWARD OPENING UNICA SYSTEM	Outward Opening	01063 - 01150N - 01151N - 01126		Two-way	closed	open	X				20

UNICA SYSTEM INWARD OPENING KIT



Functions

Kit to be combined with the UNICA and UNICA KEY cremones, composed of all the elements necessary to make the fastening mechanism of an inward-opening casement.

Online data sheet



Technical Features

Using this kit allows you to convert the UNICA mechanism into a cremone for inward opening.
All this is complemented by the elements (2 blocks, 2 terminals and 2 strikers) needed to make the sash fastening mechanism.

Materials

Plate, blocks, terminals and strikers in black polyamide
Sliders and racks in zinc plated zamak
Stainless steel screws

Art. 04070

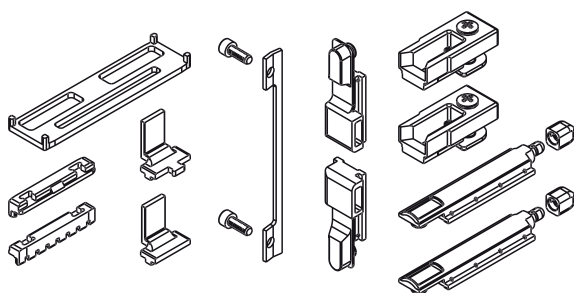

Art. 0407601

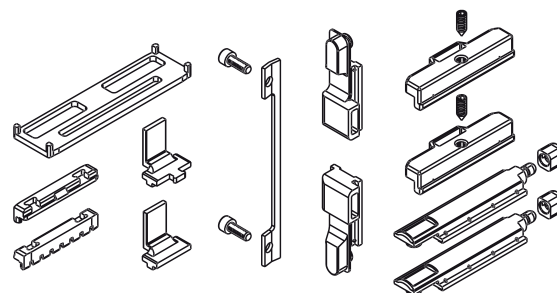

Item code	Description	PROFILE CROSS - SECTION	Type	Can be combined with	Operation	Pull handle 0°	Pull handle 90°	Base Raw	Anodised Elox	Painted	Trend/Gold Brass	Pieces per pack
04070	KIT FOR INWARD OPENING UNICA SYSTEM	C001-C012-C013-C014-C015-C017	Sash	01063 - 01150N - 01151N - 01126	Two-way	closed	open	X				50
0407601	KIT FOR IN. OPENING UNICA SYSTEM	C009	Sash	01063 - 01150N - 01151N - 01126	Two-way	closed	open	X				50

TWIN CATCH



Functions

Device for closing bottom-hung windows for front mounting, it requires no machining on the profile.

Online data sheet



Technical Features

Quick fixing on the sash channel by means of contrast grub screws. The TWIN catch is compression adjustable on the seals. A lever control is available for use in conjunction with the corresponding supports. The lever actuates the opening of the catch but it is not snap fitting on the base. This enables using it as if it were an away lever: to open the bottom-hung window you will need to insert the lever into place. Once opened the lever can be extracted from the base. The use of closing plugs, on bottom-hung windows with a number of TWIN catches connected together by a GIESSE antipanic bar, enables closing and simultaneously fixing the bar to the catches.

Materials

Coupling tooth and bottom recess in polyamide
Support for tooth and catch body in zamak
ABS/polycarbonate catch mechanism
Stainless steel screws, grub screws and spring
Polyamide caps

Bar application

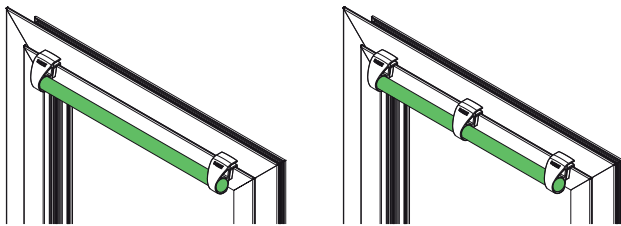

Lever Away (1) and support (2)

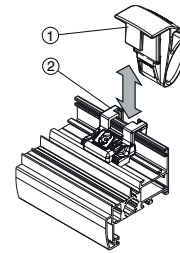

Bar-closing cap application

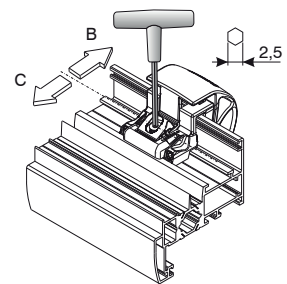
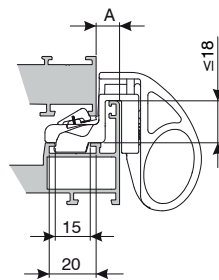
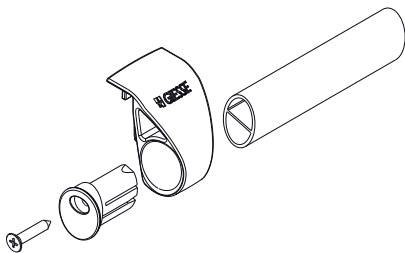

Item code	Description	PROFILE CROSS - SECTION	A (mm)	B (mm)	C (mm)	Length (mm)	Base Raw	Anodised Elox	Painted	Trend/Gold Brass	Pieces per pack
01704	TWIN CATCH	C001-C002-C003-C004-C005-C006	7 ÷ 10 mm	+ 2.1 mm	+ 1.4 mm	-	X		X	X	40
0170601	TWIN CATCH	C007-C008	8 mm	+ 1.4 mm	+ 1.4 mm	-	X		X	X	40
02317	TWIN BAR CLOSING PLUG	-	-	-	-	-			X		10
07843	HANDLE BAR	-	-	-	-	950			X		1
07844	HANDLE BAR	-	-	-	-	1150			X		1
07845	HANDLE BAR	-	-	-	-	1450			X		1

GRISBI CATCH



Functions

Fastening mechanism of bottom-hung windows for external application, made of extruded aluminium with internal guide of polyamide

Online data sheet



Technical Features

Fast mounting, it can be applied on all types of profile using the 4 polyamide shims alternately or in combination.

The combinations of the shims require using the catch in steps of (mm): 3 - 4 - 5 - 6 - 7 - 8 - 9 - 10 - 11 - 12 - 13

Note: For very thin thickness, it is recommended to decrease the diameter of the hole that receives the self-tapping screw.

Materials

Body, ring and counterplate in extruded aluminium
Shims and internal guide in polyamide
Zinc-nickel plated steel screws

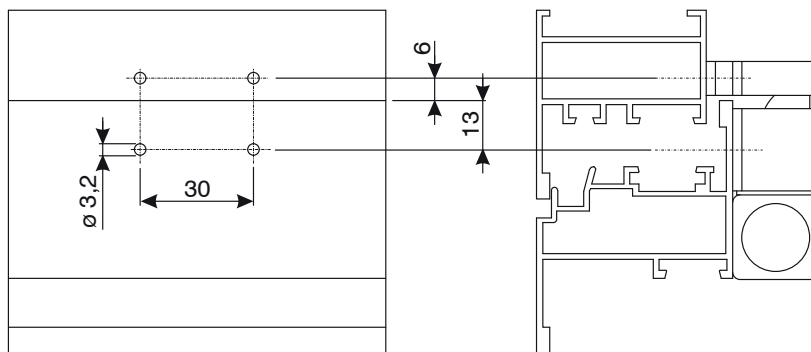
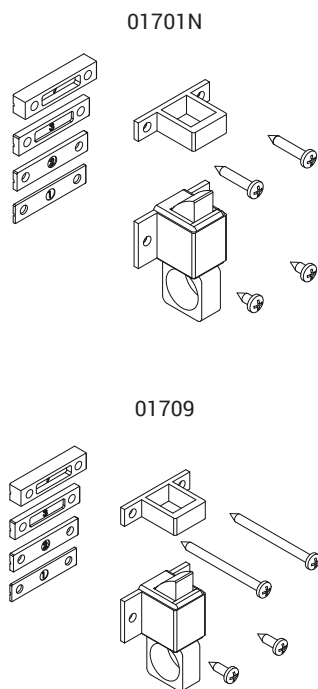

Item code	Description	PROFILE CROSS - SECTION	Base Raw	Anodised Elox	Painted	Trend/Gold Brass	Pieces per pack
01701N	GRISBI CATCH	C001-C002-C003-C004-C005-C006-C007-C008-C009-C012	X	X	X		50
01709	GRISBI CATCH - PVC	C001-C002-C003-C004-C005-C006-C007-C008-C009-C012		X	X		50



RIVO CATCH

Functions

Fastening mechanism of windows for external application, completely made of polyamide reinforced with fibreglass.

[Online data sheet](#)



Technical Features

Fast assembly, it can be applied on all types of profile using the 3 polyamide shims alternately or in combination. The combinations of the shims require using the catch in steps of 4.5 - 5.5 - 7 mm.

Materials

Body, drawer, counterplate and shims in polyamide
Zinc-nickel plated steel screws

Parts

4 Self-tapping screws 3.9x16
3 Polyamide shims

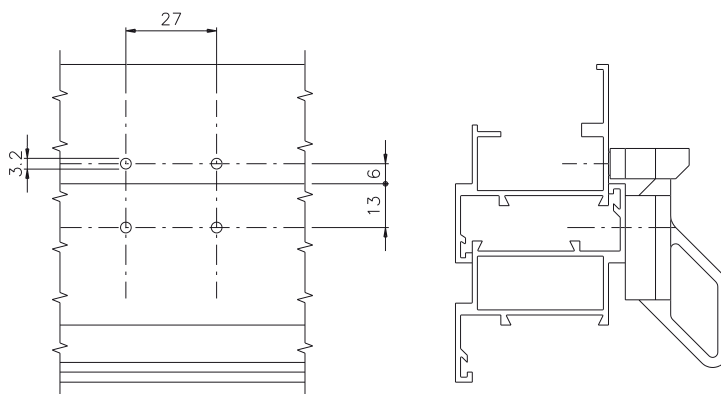

Item code	Description	Note	Base Raw	Anodised Elox	Painted	Trend/Gold Brass	Pieces per pack
01711	RIVO CATCH		X				50

BRAVO FLAT HANDLE - EURO LINE



Functions

Reversible lever handle for outdoor application for top-hung windows and pivoting windows. The BRAVO flat handle provides continuity for the EURO line also for top-hung and pivoting windows.

Online data sheet



Technical Features

Specific for step 6.5-7-8 mm.
Side reversal possible by reversing the handle and the limit stop inside the case.
Reduced machining on the profiles.

Materials

Handle and case in painted die-cast aluminium
Die-cast zamak plate
Nib in white die-cast zinc plated Zamak
Zamak keeper plate
Black polyamide shims, bush and stop
Zinc plated steel plate and keeper plate fixing screws
Stainless steel case fixing screws

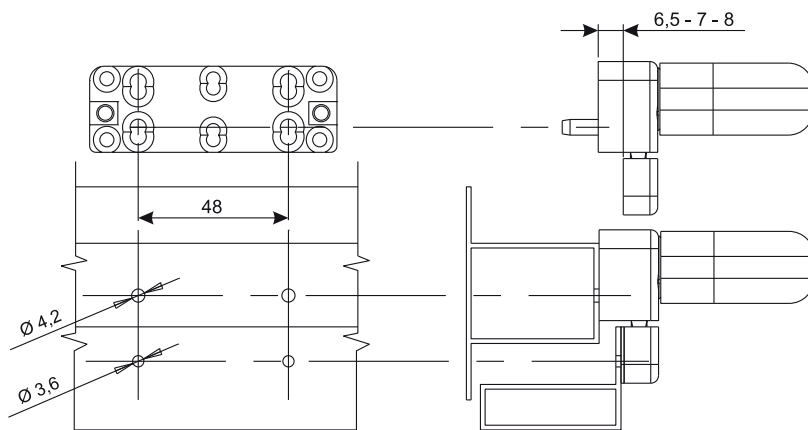
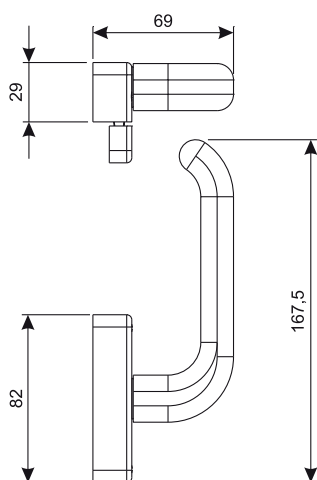

Item code	Description	Profile	Step (mm)	Base Raw	Anodised Elox	Painted	Trend/Gold Brass	Pieces per pack
01650N	BRAVO FLAT HANDLE-EURO LINE	Overlap	6,5 - 7 - 8	X		X		20
01652N	BRAVO FLAT HANDLE-EURO LINE	Flush		X		X		20

BRAVO FLAT HANDLE - PRIMA LINE



Functions

Reversible lever handle for outdoor application for top-hung windows and pivoting windows. The BRAVO flat handle provides continuity for the PRIMA line also for top-hung and pivoting windows.

Online data sheet



Technical Features

Specific for step 6.5-7-8 mm.
Side reversal possible by reversing the handle and the limit stop inside the case.
Reduced machining on the profiles.

Materials

Handle and case in painted die-cast aluminium
Die-cast zamak plate
Nib in white die-cast zinc plated Zamak
Zamak keeper plate
Black polyamide shims, bush and stop
Zinc plated steel plate and keeper plate fixing screws
Stainless steel case fixing screws

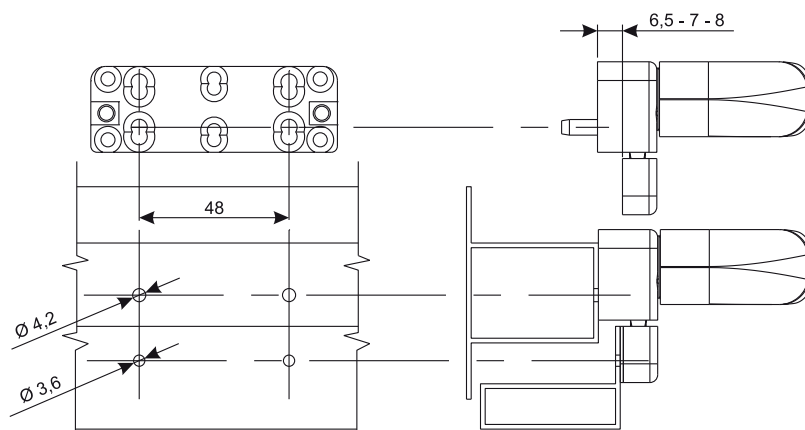
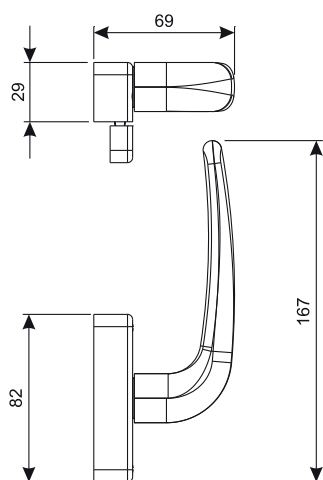

Item code	Description	Profile	Step (mm)	Base Raw	Anodised Elox	Painted	Trend/Gold Brass	Pieces per pack
01640N	BRAVO FLAT HANDLE-PRIMA LINE	Overlap	6,5 - 7 - 8	X		X		20
01642N	BRAVO FLAT HANDLE-PRIMA LINE	Flush		X		X		20



BRASS HANDLES

Functions

Straight tubular brass handle to be applied on aluminium doors.

Online data sheet



Technical Features

Thick brass tubular handle with a thick transparent electrostatic coating, fired at 150°.

Fixing to the connections is done with pins for external applications or grub screws for internal applications.

The handle can be mounted subsequently on site simply by inserting two pins, thus avoiding any damage during transportation or when installing the door.

Supplied with the handle there are two fixing grub screws.

Materials

Brass handle

Zinc plated steel grub screws

Straight brass handle

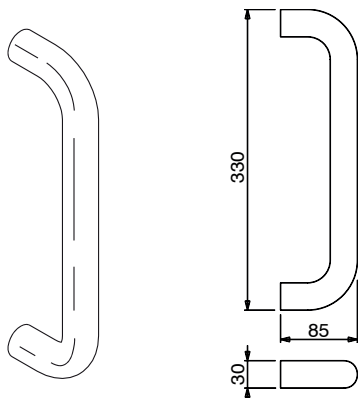

Double curved brass handle

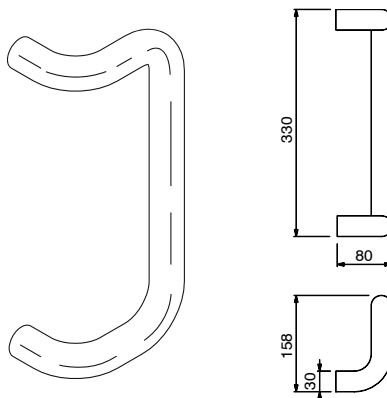

Brass elbow handle

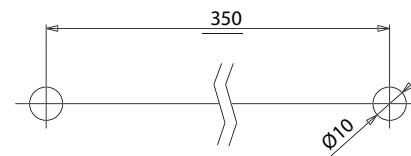
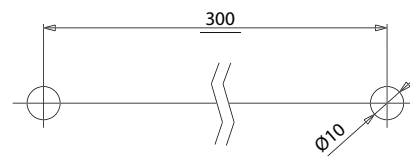
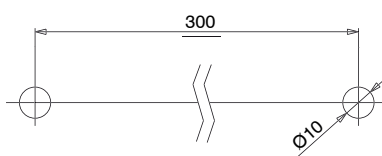
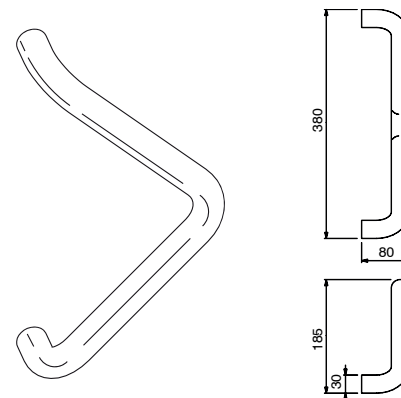

Item code	Description	C/C distance for drilling [mm]	Base Raw	Anodised Elox	Painted	Trend/Gold Brass	Pieces per pack
02609	BIKE STRAIGHT brass HANDLE	300			X	X	2
02610	BIKE DOUBLE CURVED brass HANDLE	300			X	X	2
02611	BIKE brass ELBOW HANDLE	350			X	X	2



PANIC EXIT DEVICE AP001

Functions

PUSH-BAR type of panic exit device for surface mounting.

Technical Features

The AP001 system is available in 3 versions:

- LATERAL (1 LOCKING POINT)
- TOP/BOTTOM
- MODULAR (3 LOCKING POINTS)

AP001 is to be coupled with the oval push-bar, sold separately, available in three different widths and additional locking mechanisms (top/bottom and lateral version).

The handle is easily reversible: rotation of the bracket allows its application on right-hand and left-hand doors, without any additional operation.

The product is supplied with the fitting instructions, containing paper templates for machining the profile and the product maintenance manual.

AP001 is ideal for use on fire doors when paired with accessories that are specific for this use

Certifications

The AP001 system is certified to UNI EN 1125:2008 standards and approved for CE marking, with the highest performance levels.

The field of application of these panic exit devices, referring to this standard, is the following:

- maximum weight of the door 250 kg
- maximum height of the door 2500 mm
- maximum width of the door 1300 mm
- temperature limits -10°C/+60°C

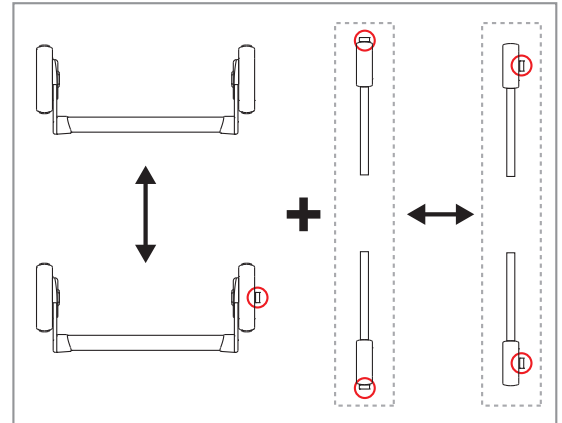

Configurations

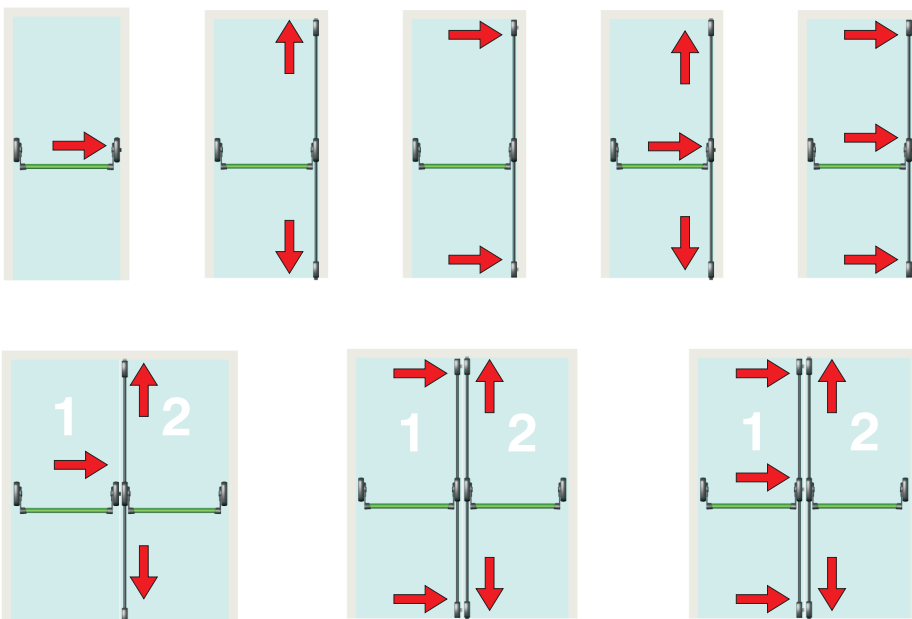

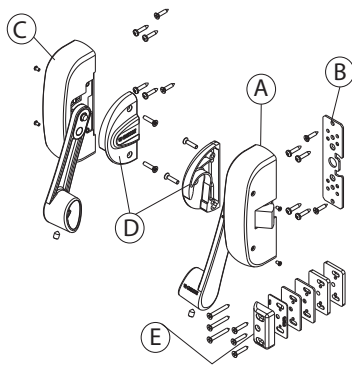

AP001 LATERAL

Functions

PUSH-BAR type of panic exit device for surface mounting.

Online data sheet



Technical Features

The lateral version AP001 system consists of:

- The main reversible mechanism (A) with a lateral spring latch and the mechanism protection plug
- the shimming plate (B) for the main mechanism
- the secondary reversible mechanism (C) and its mechanism protection plug
- the left and right bracket stop blocks (D)
- the adjustable lateral striker (E) to be installed by the lateral spring latch of the main mechanism and its stackable shims, to be placed under the striker for profiles with different steps (no. 1 shim size 1 mm, no. 2 shims size 2 mm and no. 2 shims size 4 mm)

The version suited for use on fire doors AP001F has a steel lateral striker (F) (instead of zamak as on the standard version) and a set of overlapping shims for use on profiles with different steps.

The lateral AP001 system is to be combined with the additional locking mechanisms.

Materials

- Mechanisms in zinc plated steel
- Painted steel mechanism protection plug
- Brackets and bracket stop blocks in zamak
- Striker in zamak and polyamide shims for AP001 version
- Striker and shims in stainless steel for AP001F version
- Spring latch in stainless steel
- Shimming plate in zinc plated steel
- Grub screws and fixing screws in zinc plated steel

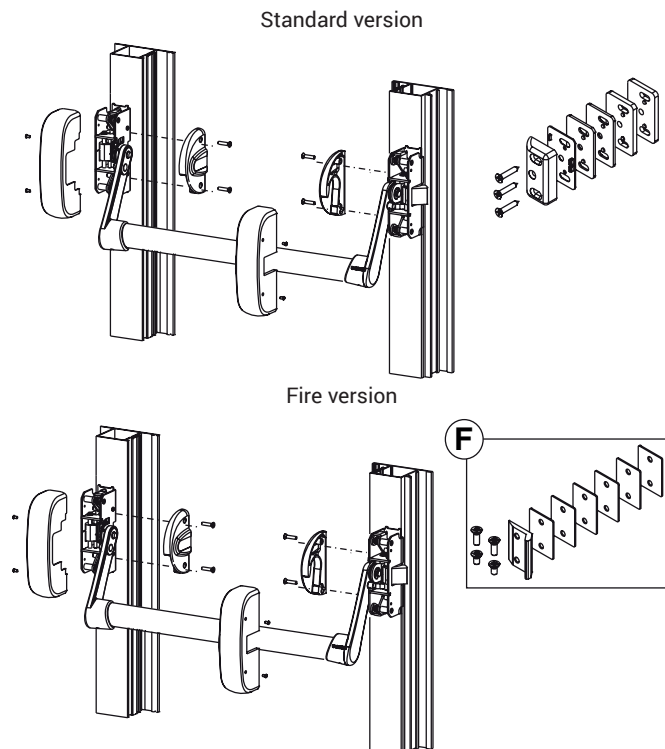
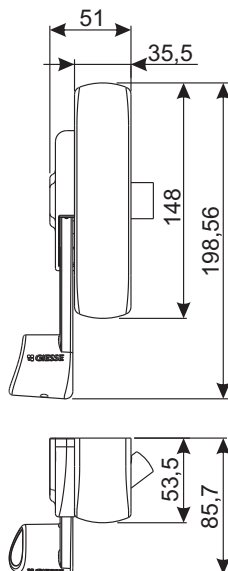

Item code	Description	Striker provided	Base Raw	Anodised Elox	Painted	Trend/Gold Brass	Pieces per pack
07310	PANIC EXIT DEVICE AP001 F LATERAL	stainless steel			X		1
07830N	PANIC EXIT DEVICE AP001 LATERAL	zamak			X		1

AP001 TOP-BOTTOM

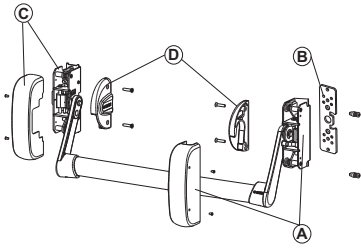

Functions

PUSH-BAR type of panic exit device for surface mounting.

[Online data sheet](#)



Technical Features

The top-bottom version AP001 system consists of:

- The main reversible mechanism (A) without a lateral spring latch that can be combined with additional locking mechanisms and the mechanism protection plug
- the shimming plate (B) for the main mechanism
- the secondary reversible mechanism (C) and its mechanism protection plug
- the left and right bracket stop blocks (D)

The top-bottom AP001 system is to be combined with the additional locking mechanisms.

AP001 is ideal for use on fire doors when paired with additional locking mechanisms that are specific for this use

Materials

- Mechanisms in zinc plated steel
- Painted steel mechanism protection plug
- Brackets and bracket stop blocks in zamak
- Shimming plate in zinc plated steel
- Grub screws and fixing screws in zinc plated steel

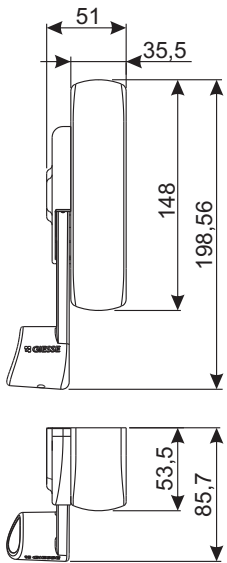

Standard version

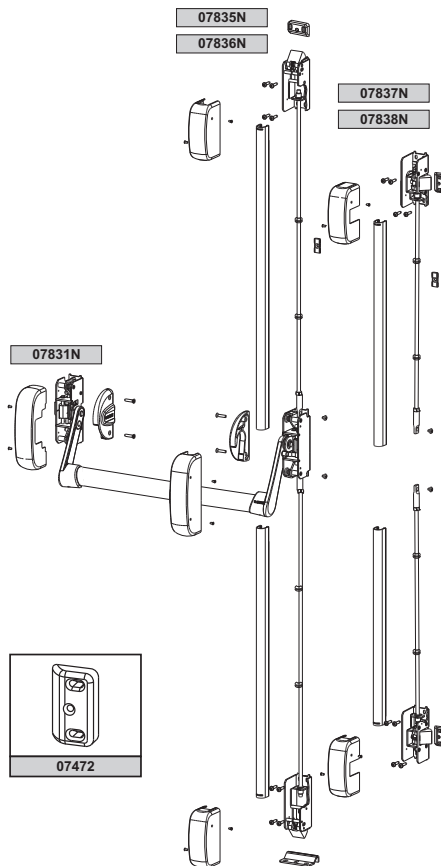

Fire version



Item code	Description	Note	Base Raw	Anodised Elox	Painted	Trend/Gold Brass	Pieces per pack
07831N	PANIC EXIT DEVICE AP001 F TOP/BOTTOM				X		1

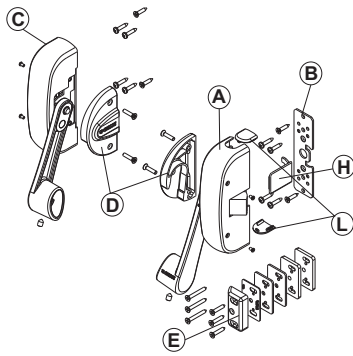

AP001 MODULAR

Functions

PUSH-BAR type of panic exit device for surface mounting.

[Online data sheet](#)



Technical Features

The modular version GS AP001 system enables, with a single product, both the lateral system configuration with one locking point and the top/bottom configuration with two or three locking points.

The modular AP001 system can be combined with the additional locking mechanisms and is composed of:

- The main reversible modular mechanism (A) with a lateral spring latch (which can be excluded) that can be combined with the additional locking mechanism kit and the mechanism protection plug
- the shimming plate (B) for the main mechanism
- the secondary reversible mechanism (C) and its mechanism protection plug
- the left and right bracket stop blocks (D)
- the adjustable lateral striker (E) to be installed by the lateral spring latch of the main mechanism and its stackable shims, to be placed under the striker for profiles with different steps (no. 1 shim size 1 mm, no. 2 shims size 2 mm and no. 2 shims size 4 mm)
- the disabling plug of the side spring latch (H)
- the caps for closing the slots of the main mechanism (L)

The version suited for use on fire doors AP001F has a steel lateral striker (F) (instead of zamak as on the standard version) and a set of overlapping shims for use on profiles with different steps

Materials

- Mechanisms in zinc plated steel
- Painted steel mechanism protection plug
- Brackets and bracket stop blocks in zamak
- Striker in zamak and polyamide shims for AP001 version
- Striker and shims in stainless steel for AP001F version
- Spring latch in stainless steel
- Shimming plate in zinc plated steel
- Plug for disabling spring latch and slot plugs in polyamide

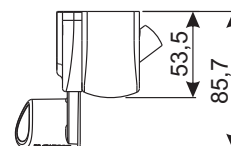
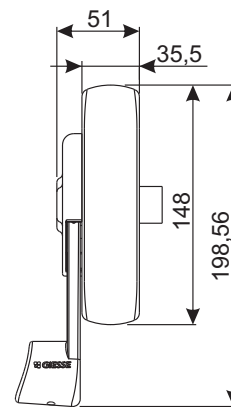
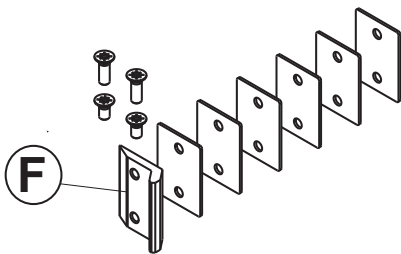

PANIC EXIT DEVICE AP001

Standard version

Fire version

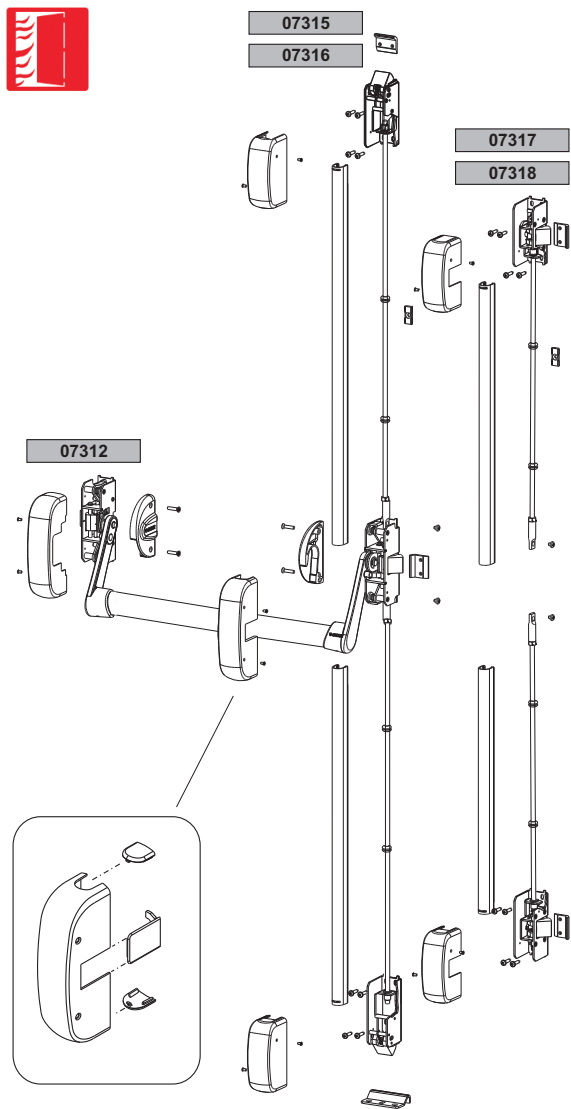
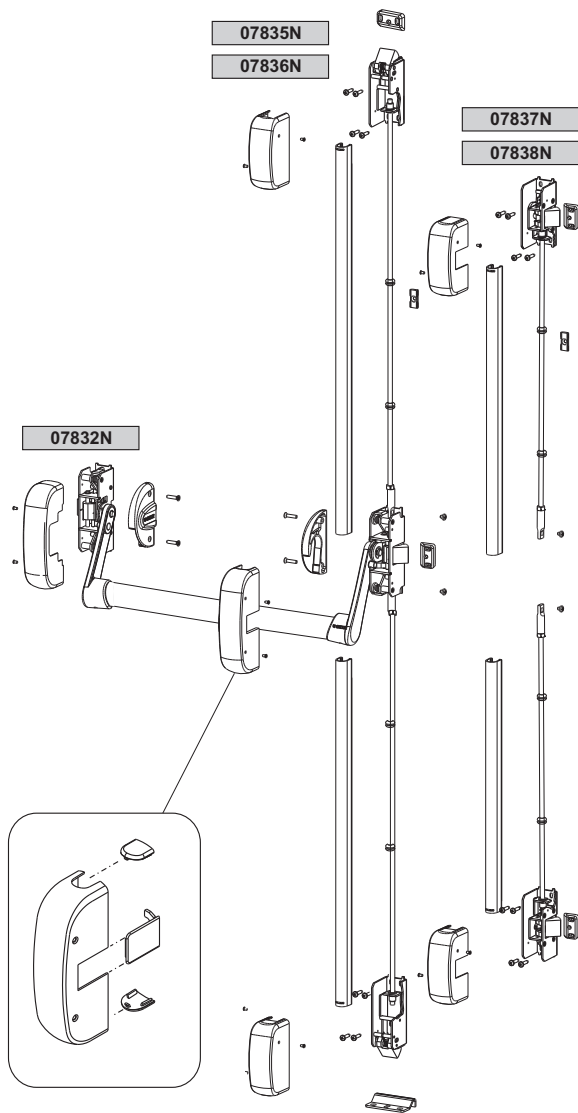

Item code	Description	Striker provided	Base Raw	Anodised Elox	Painted	Trend/Gold Brass	Pieces per pack
07312	PANIC EXIT DEVICE AP001 F MODULAR	stainless steel			X		1
07832N	PANIC EXIT DEVICE AP001 MODULAR	zamak			X		1



PUSH-BARS AP001

Functions

Push-bar for panic exit devices AP001 and AP100

[Online data sheet](#)



Technical Features

Available in various lengths.
Fixing to the handle brackets by means of grub screws.

Materials

Painted extruded aluminium bar

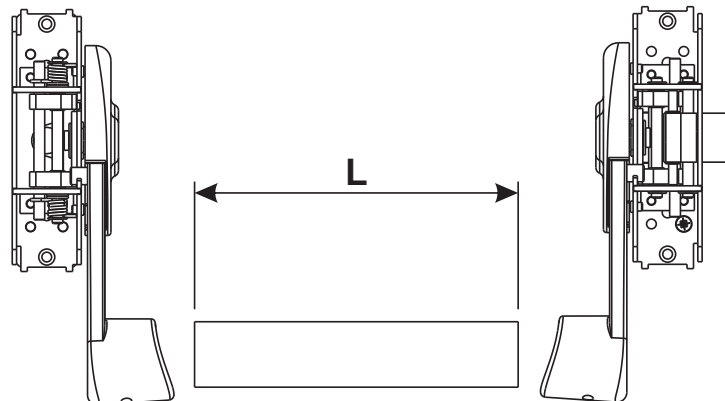

Item code	Description	Length (mm)	Sash width [mm]	Base Raw	Anodised Elox	Painted	Trend/Gold Brass	Pieces per pack
07843	HANDLE BAR	950	up to 1000 mm			X		1
07844	HANDLE BAR	1150	from 1001 to 1200 mm			X		1
07845	HANDLE BAR	1450	from 1201 to 1500 mm			X		1

ADDITIONAL LOCKING MECHANISMS AP001

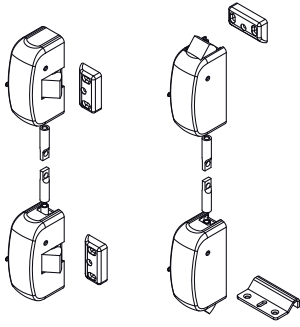

Functions

The rod and spring latches kit is used to create additional locking points on the door.

Online data sheet



Technical Features

The kit of rods and spring latches for making additional lock points on the door is available in two versions:

- top/bottom for standard doors and fire doors, in a short version and long version. Ideal for one-sash doors that you want to close with greater security than with the lateral system or for the secondary sash of a two-sash door
- side for standard doors and fire doors, in a short version and long version. Ideal for single leaf doors where you do not include floor striker plates or for tall doors where it is difficult to make the top lock point.

The kits consist of:

- the spring latches for top/bottom (A) or lateral (B) fastening mechanisms
- the threaded rods (C)
- the rod covering (D)
- the floor striker and the upper striker with their shims for the top/bottom version (E)
- the strikers with their shims for the side version (F)
- fixing components (screws, bushings, washers)

Materials

- Mechanisms in zinc plated steel
- Painted steel mechanism protection plug
- Spring latch in stainless steel
- Threaded rods in zinc plated steel
- Painted steel rod casing
- Screws and fixing elements in zinc plated steel
- Top/side striker in zamak and polyamide shims

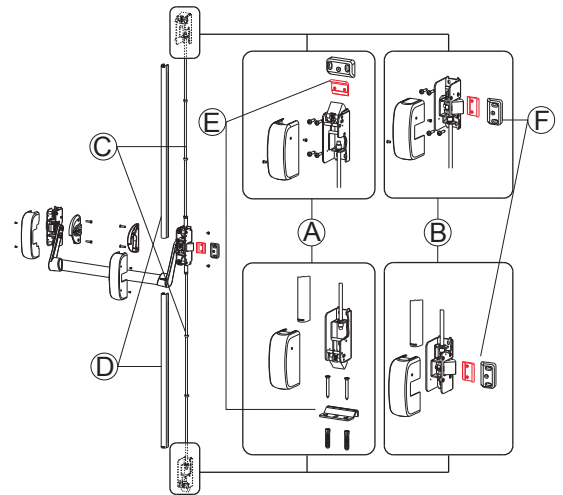
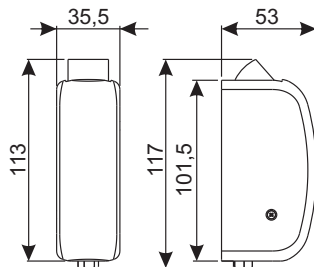

Item code	Description	Locking mechanism type	Version	Sash height [mm]	Strikers provided	Base Raw	Anodised Elox	Painted	Trend/Gold Brass	Pieces per pack
07315	FIRE-RATED ADDITIONAL LOCKING MECHANISMS	TOP/BOTTOM (2 LOCKING POINTS)	SHORT	up to 2640 mm	upper and floor in stainless steel			X		1
07316	FIRE-RATED ADDITIONAL LOCKING MECHANISMS	TOP/BOTTOM (2 LOCKING POINTS)	LONG	from 2641 mm to 3150 mm	upper and floor in stainless steel			X		1
07317	FIRE-RATED ADDITIONAL LOCKING MECHANISMS	LATERAL	SHORT	up to 2640 mm	side elements in stainless steel			X		1
07318	FIRE-RATED ADDITIONAL LOCKING MECHANISMS	LATERAL	LONG	from 2641 mm to 3150 mm	side elements in stainless steel			X		1
07835N	ADDITIONAL FASTENING MECHANISMS	TOP/BOTTOM (2 LOCKING POINTS)	SHORT	up to 2640 mm	upper in zamak and floor in stainless steel			X		1
07836N	ADDITIONAL FASTENING MECHANISMS	TOP/BOTTOM (2 LOCKING POINTS)	LONG	from 2641 mm to 3150 mm	upper in zamak and floor in stainless steel			X		1
07837N	ADDITIONAL FASTENING MECHANISMS	LATERAL	SHORT	up to 2640 mm	side elements in zamak			X		1
07838N	ADDITIONAL FASTENING MECHANISMS	LATERAL	LONG	from 2641 mm to 3150 mm	side elements in zamak			X		1

STRIKERS FOR HANDLES AP001

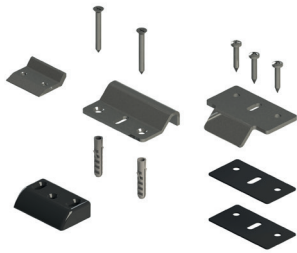

Functions

Fastening strikers to be combined with panic exit devices AP001 and AP002.

Online data sheet



Technical Features

Type 1

Lateral striker in stainless steel for panic exit devices in fire-rated version AP001F AP002F.

Ensures operation of the safety device and therefore operation of the door, also in the event of fire.

The striker has no. 6 shims of 1 mm, which can overlap, for adjusting the various series of profiles.

Fixing to the profile with self-tapping screws.

Materials

Striker and shims in stainless steel

Screws for fixing to the profile in stainless steel

Type 2

Floor striker to be placed at the bottom vertical spring latch of the panic exit devices AP001 and AP002.

Supplied with the additional spring latches, it can also be purchased separately.

Materials

Stainless steel striker

Screws for fixing to the profile in stainless steel

Plastic expansion dowels for fixing

Type 3

Adjustable side striker to be placed at the side or vertical spring latches of the panic exit devices AP001 and AP002.

Supplied with the handles and the additional spring latches, it can also be purchased separately.

The striker has no. 5 shims respectively of 1 mm, 2 mm and 4 mm, which can overlap with each other for fixing the various series of profiles.

Fixing to the profile with self-tapping screws.

Materials

Side striker in zamak

Polyamide side shims

Screws for fixing to the profile in stainless steel

Type 4

Side striker for PVC.

Materials

Stainless steel striker

Stainless steel fixing screws

Type 5

Side striker for PVC and wood.

Materials

Zamak components

Stainless steel fixing screws

Type 6

Side striker for PVC and wood.

Materials

Zamak components

Stainless steel fixing screws

Type 1

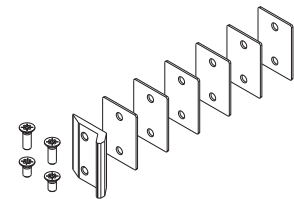

Type 2

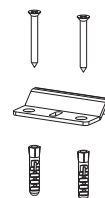

Type 3

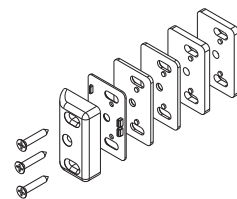

Type 4

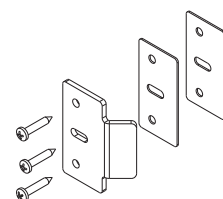

Type 5

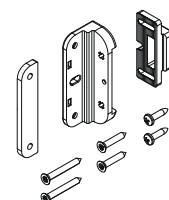

Type 6

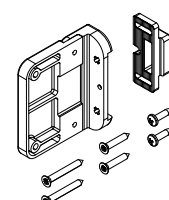

PANIC EXIT DEVICE AP001

Type 1

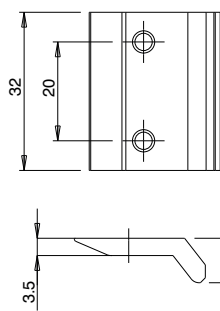

Type 2

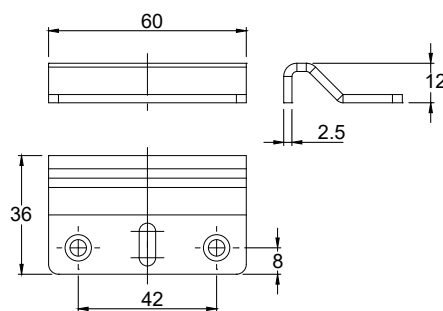

Type 4

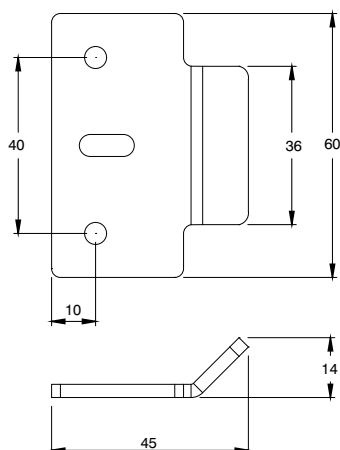

Type 5

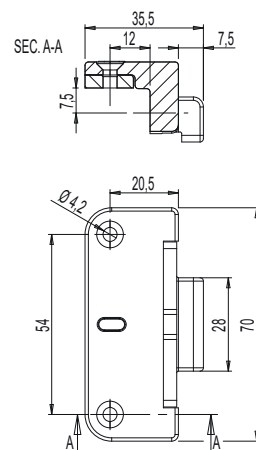

Type 6

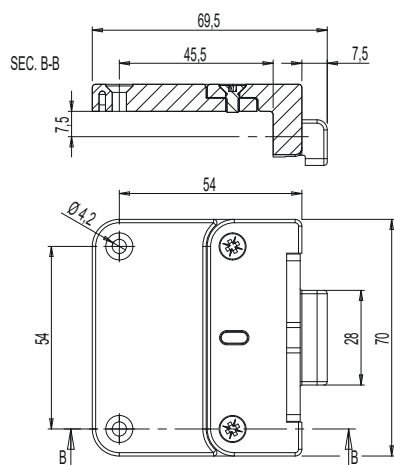

Item code	Description	Type	Base Raw	Anodised Elox	Painted	Trend/Gold Brass	Pieces per pack
07470N	LATERAL STRIKER FOR HANDLES AP001F/AP002F	1	X				10
07471	FLOOR STRIKER FOR HANDLES AP001/AP002	2	X				10
07473	LATERAL STRIKER FOR PVC FOR HANDLES AP001/AP002	4	X				10
07474	Side striker for PVC and wood AP001-AP002	5			X		10
07475	Side striker for PVC and wood L AP001-AP002	6			X		10



EXTERNAL CONTROLS

Functions

The external control common to all GS AP001 and GS AP002 panic bars, enables the operating handle to be locked in position by way of the cylinder, thus preventing the door being opened from outside.

Online data sheet



Technical Features

External handle to be fitted on the upright or centre rail of the door in conjunction with the panic exit devices AP001 and AP002.

Available in versions with a handle and with a knob, with an integrated half cylinder 31/10 or without a cylinder.

Materials

Handle in aluminium/knob in zamak

Zamak casing

Shimming plate in zinc plated steel

Square pin 8x120 and fixing screws in zinc plated steel

Cylinder and key made of nickel-plated brass

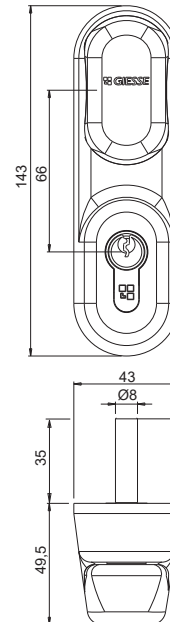
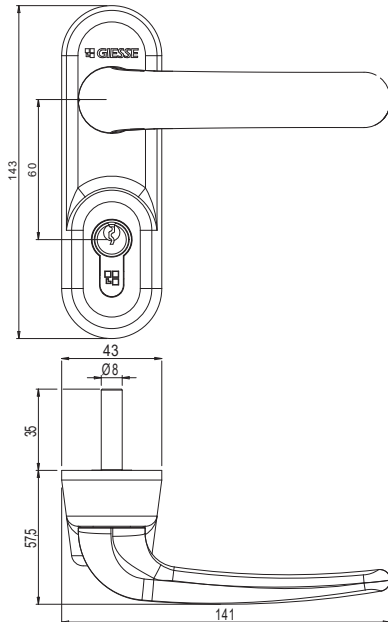

Item code	Description	Square spindle [mm]	Base Raw	Anodised Elox	Painted	Trend/Gold Brass	Pieces per pack
0732201	EXTERNAL CONTROL WITH FREE KNOB	8x120			X		1
07324	EXTERNAL CONTROL WITH FREE HANDLE	8x120			X		1

PANIC EXIT DEVICE AP002



Functions

TOUCH-BAR type panic exit device for surface mounting.

Technical Features

The AP002 system is available in 3 versions:

- LATERAL (1 LOCKING POINT)
- TOP/BOTTOM
- MODULAR (3 LOCKING POINTS)

Each of these versions is available in three different lengths:

- short version with bar size 840 mm
- medium version with bar size 1170 mm
- long version with bar size 1300 mm

Completely reversible, AP002 can be fitted on right or left opening doors without requiring any additional operation.

The product is supplied with the fitting instructions, containing paper templates for machining the profile and the product maintenance manual.

AP002 is ideal for use on fire doors when paired with hardware that is specific for this use.

Certifications

The AP002 system is certified to UNI EN 1125:2008 standards and approved for CE marking with the highest performance levels.

The field of application of these panic exit devices, referring to this standard, is the following:

- maximum weight of the door 250 kg
- maximum height of the door 2500 mm
- maximum width of the door 1300 mm
- temperature limits -10°C/+60°C

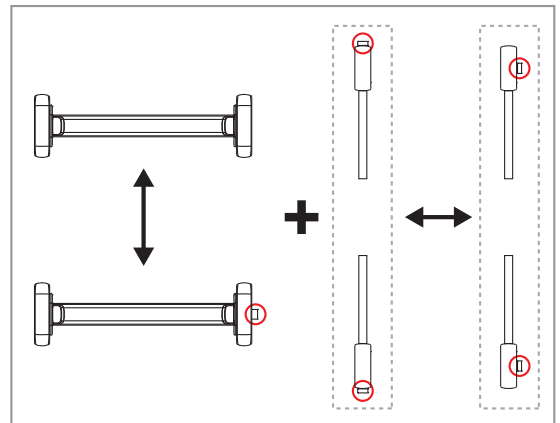

Configurations

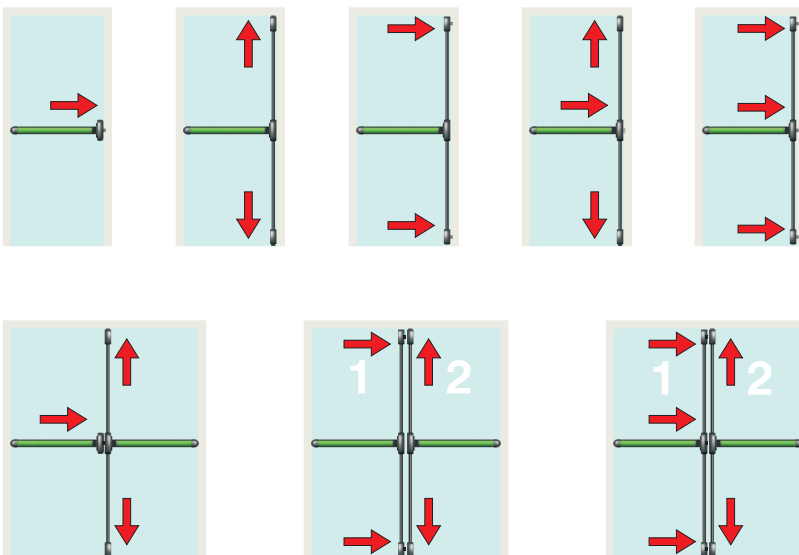

AP002 LATERAL

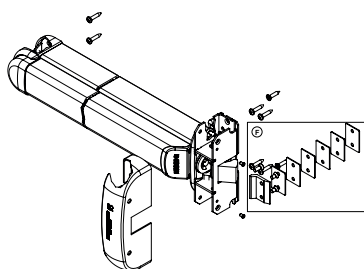

Functions

TOUCH-BAR type panic exit device for surface mounting.

Online data sheet



Technical Features

The lateral version AP002 system consists of:

- the reversible mechanism (A) with a lateral spring latch and the mechanism protection plug (B)
- the pre-assembled round coupling shim (C)
- the base with push-bar and mechanism (D), with assembled front and rear caps
- the adjustable lateral striker (E) to be installed by the lateral spring latch of the main mechanism and its stackable shims to be placed under the striker for profiles with different steps (no. 1 shim size 1 mm, no. 2 shims size 2 mm and no. 2 shims size 4 mm)

The version suited for use on fire doors AP001F has a steel lateral striker (F) (instead of zamak as on the standard version) and a set of overlapping shims for use on profiles with different steps.

The lateral AP002 system is to be combined with the additional locking mechanisms.

Materials

- Mechanism in zinc plated steel
- Painted steel mechanism protection plug
- Push-bar in extruded aluminium
- Spring latch in stainless steel
- Striker in zamak and polyamide shims for AP002 version
- Striker and shims in stainless steel for AP002F version
- Fixing screws, zinc-coated steel

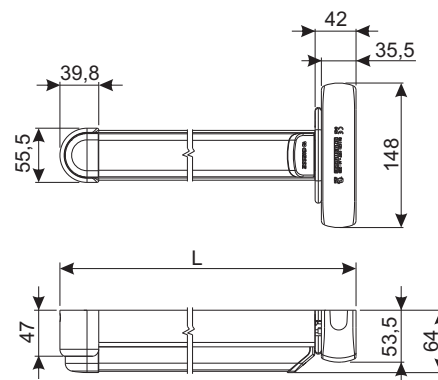
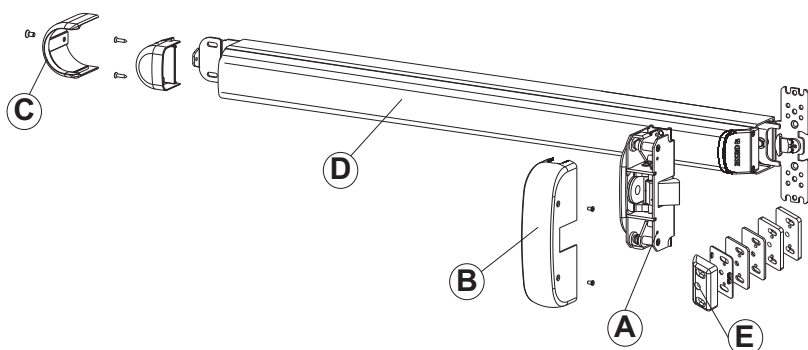

Item code	Description	Version	Bar length L [mm]	Sash width [mm]	Striker provided	Base Raw	Anodised Elox	Painted	Trend/Gold Brass	Pieces per pack
07410	PANIC EXIT DEVICE AP002 LATERAL	SHORT	840	up to 1000	zamak			X		1
07411	PANIC EXIT DEVICE AP002 LATERAL	AVERAGE	1170	from 1001 to 1200	zamak			X		1
07412	PANIC EXIT DEVICE AP002 LATERAL	LONG	1300	from 1201 to 1500	zamak			X		1
07420	PANIC EXIT DEVICE AP002F LATERAL FOR FIRE DOORS	SHORT	840	up to 1000	stainless steel			X		1
07421	PANIC EXIT DEVICE AP002F LATERAL FOR FIRE DOORS	AVERAGE	1170	from 1001 to 1200	stainless steel			X		1
07422	PANIC EXIT DEVICE AP002F LATERAL FOR FIRE DOORS	LONG	1300	from 1201 to 1500	stainless steel			X		1

AP002 TOP-BOTTOM

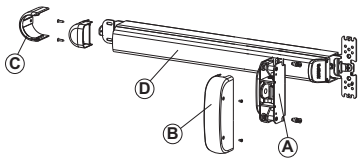

Functions

TOUCH-BAR type panic exit device for surface mounting.

Online data sheet



Technical Features

The top-bottom version AP002 system consists of:

- the reversible mechanism (A) without a lateral spring latch that can be combined with additional locking mechanisms and the mechanism protection plug (B)
- the pre-assembled round coupling shim (C)
- the base with push-bar and mechanism (D), with assembled front and rear caps

The top-bottom AP002 system is to be combined with the additional locking mechanisms.

This version is ideal for use on fire doors when paired with additional fastening mechanisms that are specific for this use.

Materials

Mechanism in zinc plated steel

Painted steel mechanism protection plug

Brackets and bracket stop blocks in zamak

Shimming plate in zinc plated steel

Zinc plated steel fixing screws and grub screws

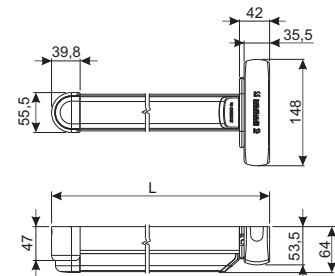

Standard version

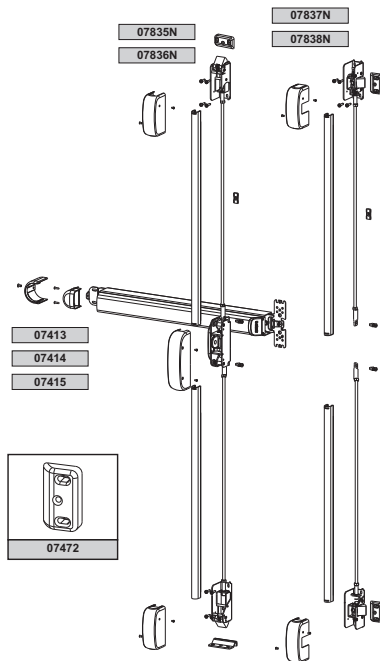

Fire version

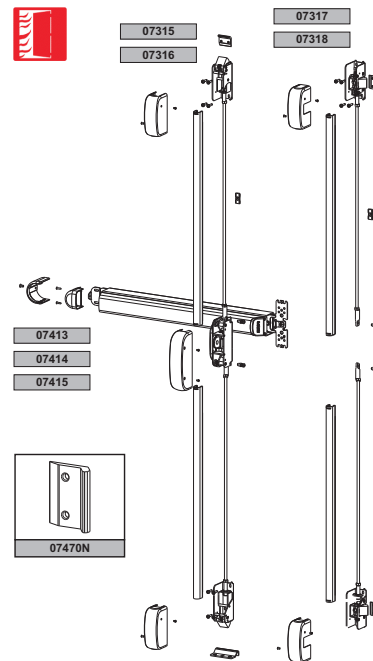

Item code	Description	Version	Bar length L [mm]	Sash width [mm]	Base Raw	Anodised Elox	Painted	Trend/Gold Brass	Pieces per pack
07413	PANIC EXIT DEVICE AP002 TOP/BOTTOM	SHORT	840	up to 1000			X		1
07414	PANIC EXIT DEVICE AP002 TOP/BOTTOM	AVERAGE	1170	from 1001 to 1200			X		1
07415	PANIC EXIT DEVICE AP002 TOP/BOTTOM	LONG	1300	from 1201 to 1500			X		1

AP002 MODULAR

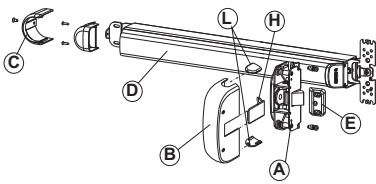

Functions

TOUCH-BAR type panic exit device for surface mounting.

Online data sheet



Technical Features

The modular version AP002 system enables, with a single article, both the side configuration with one lock point and the top/bottom configuration with two or three lock points.

The modular AP002 system is to be combined with the additional locking mechanisms.

The modular version AP002 system consists of:

- the reversible modular mechanism (A) with a lateral spring latch (which can be excluded) that can be combined with the additional locking mechanism kit and the mechanism protection plug (B)
- the pre-assembled round coupling shim (C)
- the base with push-bar and mechanism (D), with assembled front and rear caps
- the adjustable lateral striker (E) to be installed by the lateral spring latch of the main mechanism and its stackable shims to be placed under the striker for profiles with different steps (no. 1 shim size 1 mm, no. 2 shims size 2 mm and no. 2 shims size 4 mm)
- the disabling plug of the side spring latch (H)
- the caps for closing the slots of the main mechanism (L)

The version suited for use on fire doors AP002F has a steel lateral striker (F) (instead of zamak as on the standard version) and a set of overlapping shims for use on profiles with different steps.

Materials

- Mechanism in zinc plated steel
- Painted steel mechanism protection plug
- Push-bar in extruded aluminium
- Spring latch in stainless steel

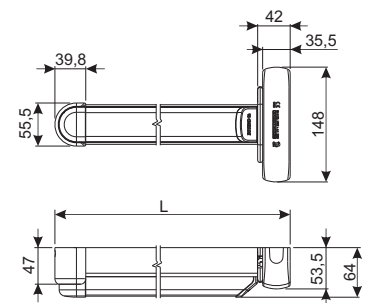

Standard version

Fire version

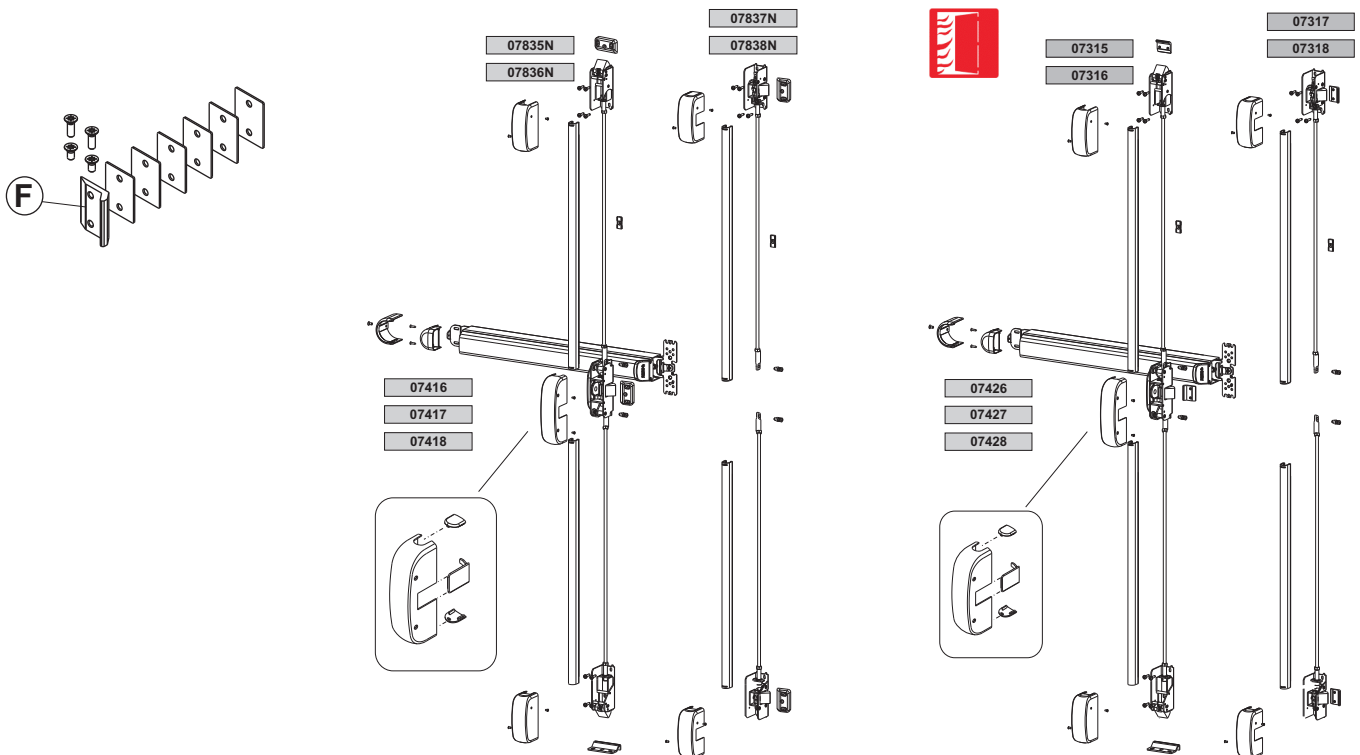

PANIC EXIT DEVICE AP002

Item code	Description	Version	Bar length L [mm]	Sash width [mm]	Striker provided	Base Raw	Anodised Elox	Painted	Trend/Gold Brass	Pieces per pack
07418	PANIC EXIT DEVICE AP002 MODULAR	LONG	1300	from 1201 to 1500	zamak			X		1
07426	PANIC EXIT DEVICE AP002F MODULAR FIRE-RATED	SHORT	840	up to 1000	stainless steel			X		1
07427	PANIC EXIT DEVICE AP002F MODULAR FIRE-RATED	AVERAGE	1170	from 1001 to 1200	stainless steel			X		1
07428	PANIC EXIT DEVICE AP002F MODULAR FIRE-RATED	LONG	1300	from 1201 to 1500	stainless steel			X		1

ADDITIONAL LOCKING MECHANISMS AP002

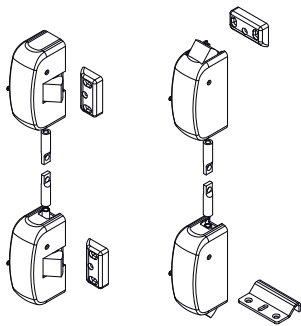

Functions

The rod and spring latches kit is used to create additional locking points on the door.

[Online data sheet](#)



Technical Features

The kit of rods and spring latches for making additional lock points on the door is available in two versions:

- top/bottom for standard doors and fire doors, in a short version and long version. Ideal for one-sash doors that you want to close with greater security than with the lateral system or for the secondary sash of a two-sash door
- side for standard doors and fire doors, in a short version and long version. Ideal for single leaf doors where you do not include floor striker plates or for tall doors where it is difficult to make the top lock point.

The kits consist of:

- the spring latches for top/bottom (A) or lateral (B) fastening mechanisms
- the threaded rods (C)
- the rod covering (D)
- the floor striker and the upper striker with their shims for the top/bottom version (E)
- the strikers with their shims for the side version (F)
- fixing components (screws, bushings, washers)

Materials

- Mechanisms in zinc plated steel
- Painted steel mechanism protection plug
- Spring latch in stainless steel
- Threaded rods in zinc plated steel
- Painted steel rod casing
- Screws and fixing elements in zinc plated steel
- Top/side striker in zamak and polyamide shims

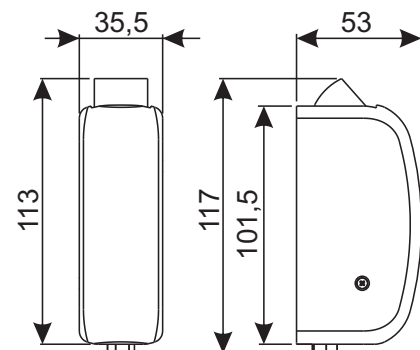
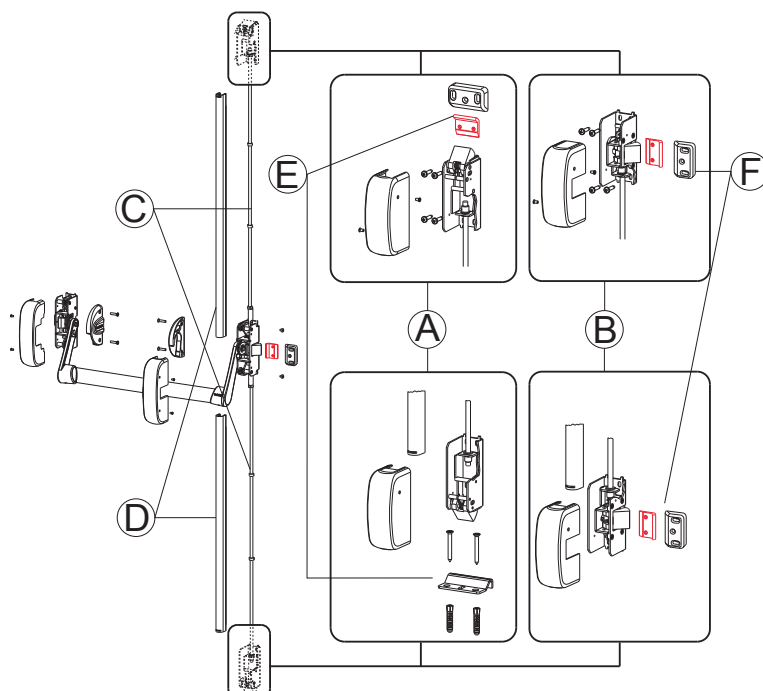

PANIC EXIT DEVICE AP002

Item code	Description	Locking mechanism type	Version	Sash height [mm]	Strikers provided	Base Raw	Anodised Elox	Painted	Trend/Gold Brass	Pieces per pack
07315	FIRE-RATED ADDITIONAL LOCKING MECHANISMS	TOP/BOTTOM (2 LOCKING POINTS)	SHORT	up to 2640 mm	upper and floor in stainless steel			X		1
07316	FIRE-RATED ADDITIONAL LOCKING MECHANISMS	TOP/BOTTOM (2 LOCKING POINTS)	LONG	from 2641 mm to 3150 mm	upper and floor in stainless steel			X		1
07317	FIRE-RATED ADDITIONAL LOCKING MECHANISMS	LATERAL	SHORT	up to 2640 mm	side elements in stainless steel			X		1
07318	FIRE-RATED ADDITIONAL LOCKING MECHANISMS	LATERAL	LONG	from 2641 mm to 3150 mm	side elements in stainless steel			X		1
07835N	ADDITIONAL FASTENING MECHANISMS	TOP/BOTTOM (2 LOCKING POINTS)	SHORT	up to 2640 mm	upper in zamak and floor in stainless steel			X		1
07836N	ADDITIONAL FASTENING MECHANISMS	TOP/BOTTOM (2 LOCKING POINTS)	LONG	from 2641 mm to 3150 mm	upper in zamak and floor in stainless steel			X		1
07837N	ADDITIONAL FASTENING MECHANISMS	LATERAL	SHORT	up to 2640 mm	side elements in zamak			X		1
07838N	ADDITIONAL FASTENING MECHANISMS	LATERAL	LONG	from 2641 mm to 3150 mm	side elements in zamak			X		1

STRIKERS FOR HANDLES AP002

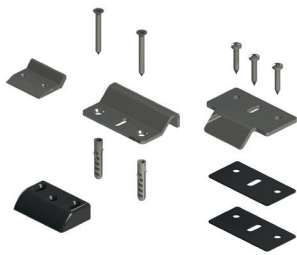

Functions

Fastening strikers to be combined with panic exit devices AP001 and AP002.

Online data sheet



Technical Features

Type 1

Lateral striker in stainless steel for panic exit devices in fire-rated version AP001F AP002F. Ensures operation of the safety device and therefore operation of the door, also in the event of fire. The striker has no. 6 shims of 1 mm, which can overlap, for adjusting the various series of profiles. Fixing to the profile with self-tapping screws.

Materials

Striker and shims in stainless steel
Screws for fixing to the profile in stainless steel

Type 2

Floor striker to be placed at the bottom vertical spring latch of the panic exit devices AP001 and AP002. Supplied with the additional spring latches, it can also be purchased separately.

Materials

Stainless steel striker
Screws for fixing to the profile in stainless steel
Plastic expansion dowels for fixing

Type 3

Adjustable side striker to be placed at the side or vertical spring latches of the panic exit devices AP001 and AP002. Supplied with the handles and the additional spring latches, it can also be purchased separately. The striker has no. 5 shims respectively of 1 mm, 2 mm and 4 mm, which can overlap with each other for fixing the various series of profiles. Fixing to the profile with self-tapping screws.

Materials

Side striker in zamak
Polyamide side shims
Screws for fixing to the profile in stainless steel

Type 4

Side striker for PVC.

Materials

Stainless steel striker
Stainless steel fixing screws

Type 5

Side striker for PVC and wood.

Materials

Zamak components
Stainless steel fixing screws

Type 6

Side striker for PVC and wood.

Materials

Zamak components
Stainless steel fixing screws

Type 1

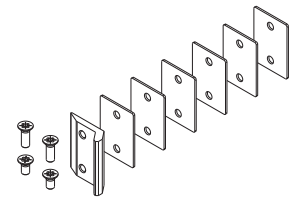

Type 2

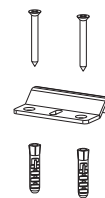

Type 3

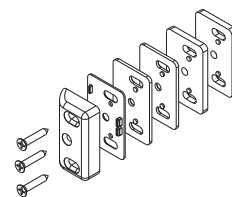

Type 4

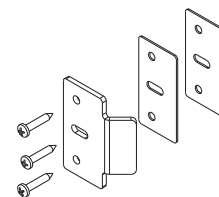

Type 5

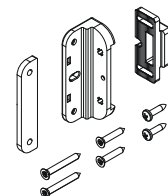

Type 6

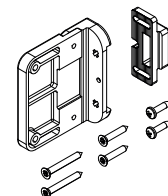

Type 1

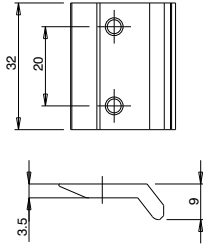

Type 2

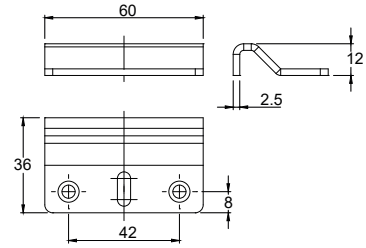

Type 3

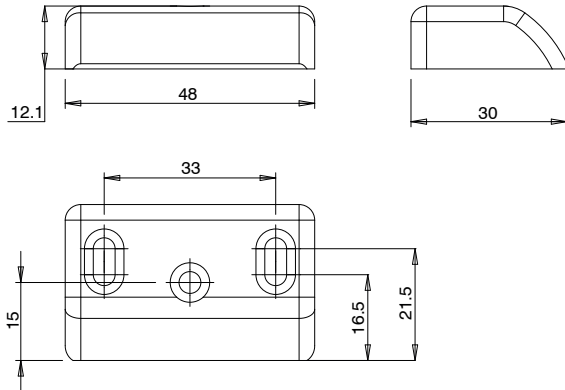

Type 4

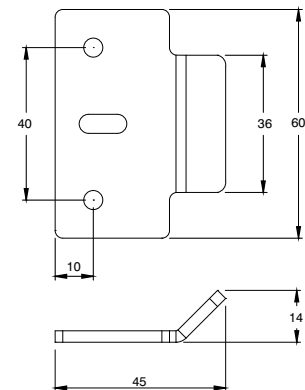

Type 5

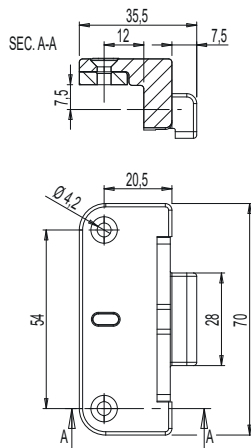

Type 6

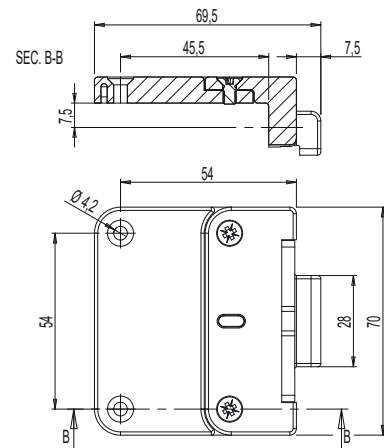

Item code	Description	Type	Base Raw	Anodised Elox	Painted	Trend/Gold Brass	Pieces per pack
07470N	LATERAL STRIKER FOR HANDLES AP001F/AP002F	1	X				10
07471	FLOOR STRIKER FOR HANDLES AP001/AP002	2	X				10
07472	LATERAL STRIKER FOR HANDLES AP001/AP002	3	X				10
07473	LATERAL STRIKER FOR PVC FOR HANDLES AP001/AP002	4	X				10
07474	Side striker for PVC and wood AP001-AP002	5			X		10
07475	Side striker for PVC and wood L AP001-AP002	6			X		10



EXTERNAL CONTROLS

Functions

The external control common to all GS AP001 and GS AP002 panic bars, enables the operating handle to be locked in position by way of the cylinder, thus preventing the door being opened from outside.

Online data sheet



Technical Features

External handle to be fitted on the upright or centre rail of the door in conjunction with the panic exit devices AP001 and AP002.

Available in versions with a handle and with a knob, with an integrated half cylinder 31/10 or without a cylinder.

Materials

Handle in aluminium/knob in zamak

Zamak casing

Shimming plate in zinc plated steel

Square pin 8x120 and fixing screws in zinc plated steel

Cylinder and key made of nickel-plated brass

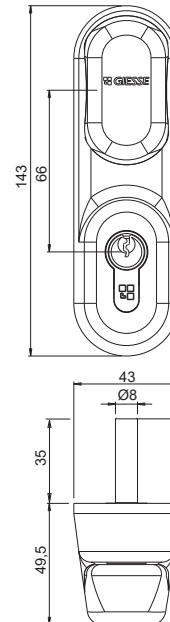
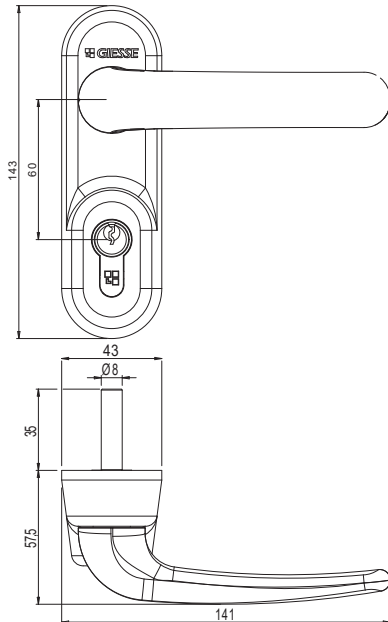

Item code	Description	Square spindle [mm]	Base Raw	Anodised Elox	Painted	Trend/Gold Brass	Pieces per pack
0732201	EXTERNAL CONTROL WITH FREE KNOB	8x120			X		1
07324	EXTERNAL CONTROL WITH FREE HANDLE	8x120			X		1

PANIC EXIT DEVICE AP100



PANIC EXIT DEVICE AP100

Functions

PUSH BAR type safety panic exit device for slip-on mounting.

Technical Features

The security version AP100 system consists of:

- AP100 locking mechanism
- Oval push-bar, sold separately, available in three different widths
- Antipanic security locks with one and three locking points, to be chosen depending on the profile and the type of application with specific counterplates
- Counterplates for AP100 locks

The pressure on the bar determines the rotation of a special square pin (emergency function) which operates the security lock coupled with the device only when opening.

The security locks of this type have the characteristic of being able to be opened by simply turning the handle spindle, even when the bolt is closed. The special conditions of installation make the emergency function active only on the inside of the door.

The mechanism, locks and emergency function can be easily reversed for application on both left and right handed doors.

The product is supplied with the fitting instructions, containing paper templates for machining the profile and the product maintenance manual.

Certifications

The AP100 system is certified to UNI EN 1125:2008 standards and approved for CE marking, with the highest performance levels.

The field of application of these panic exit devices, referring to this standard, is the following:

- maximum weight of the door 250 kg
- maximum height of the door 2500 mm
- maximum width of the door 1300 mm
- temperature limits -10°C/+60°C

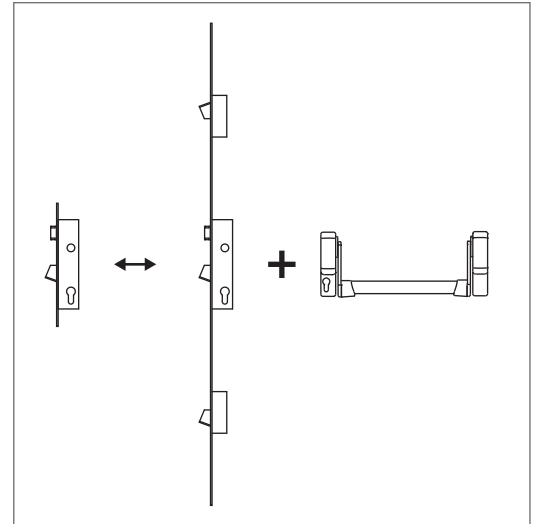

Configurations

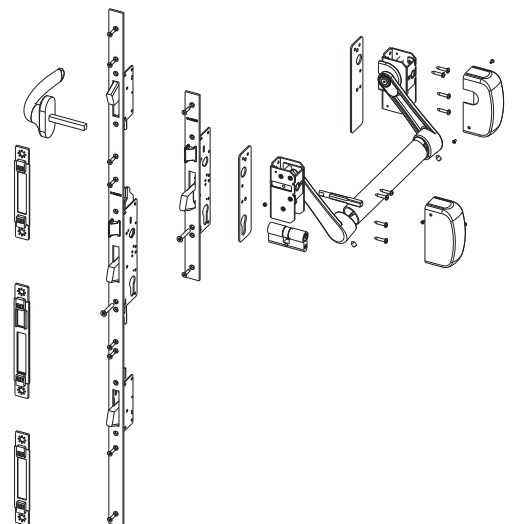
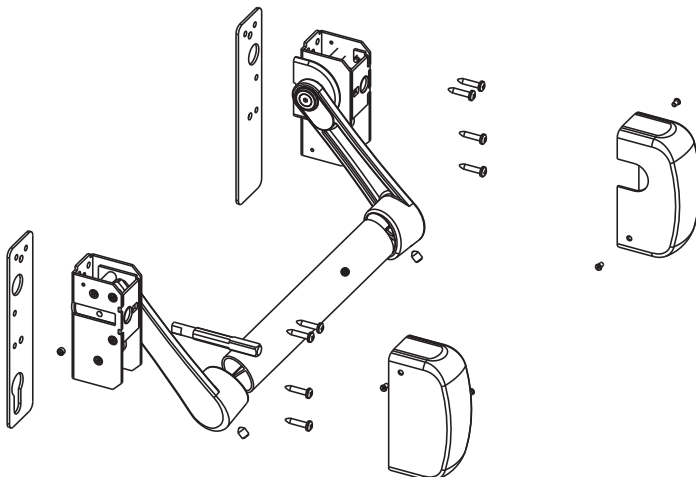
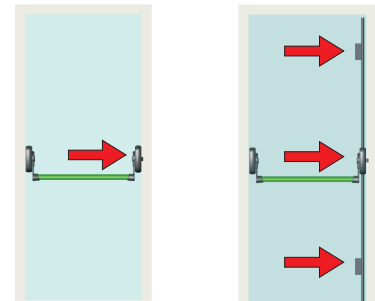

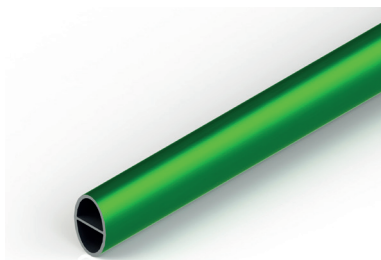

PUSH-BARS AP100

Functions

Operating bar for anti-panic handles AP001 and AP100.

[Online data sheet](#)



Technical Features

Available in various lengths.

Fixing to the handle brackets by means of grub screws.

Materials

Painted extruded aluminium bar

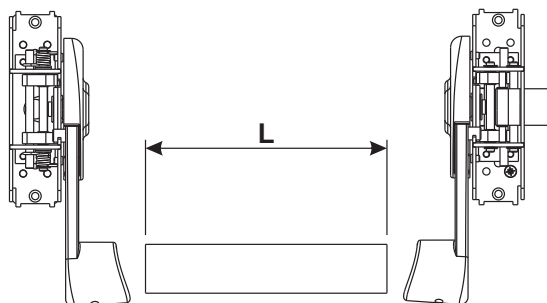

Item code	Description	Length (mm)	Sash width [mm]	Base Raw	Anodised Elox	Painted	Trend/Gold Brass	Pieces per pack
07843	HANDLE BAR	950	up to 1000 mm			X		1
07844	HANDLE BAR	1150	from 1001 to 1200 mm			X		1
07845	HANDLE BAR	1450	from 1201 to 1500 mm			X		1

PANIC EXIT DEVICE AP100

AP100 MECHANISM

Functions

PUSH BAR type safety panic exit device for slip-on mounting.

[Online data sheet](#)



Technical Features

The AP100 mechanism consists of:

- main operating device (A) and its mechanism protection plug
 - secondary operating device (B) and its mechanism protection plug
 - shimming plates (C)
 - square connecting pin between the fastening mechanism and lock (D)
- The device to insert should be combined with the following components:
- oval push-bar, sold separately, available in three different widths
 - the security locks with one-point and three-point fastening, to be chosen depending on the profile and the type of application with specific counterplates
 - specific strikers for the lock used cylinder

Materials

- Mechanisms in zinc plated steel
- Painted steel mechanism protection plug
- Brackets in Zamak
- Shimming plates in zinc plated steel
- Grub screws and fixing screws in zinc plated steel

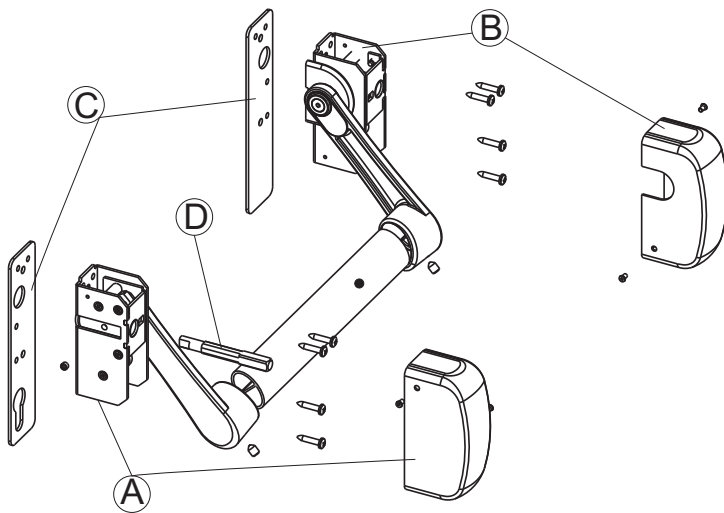

Item code	Description	Note	Base Raw	Anodised Elox	Painted	Trend/Gold Brass	Pieces per pack
07833	PANIC EXIT DEVICE AP100				X		1

CENTRAL LOCKS FOR EMERGENCY EXITS



Functions

Central lock, slip-on version for aluminium uprights , available with flat front and "U" shaped front, equipped with spring latch and pivoting bolt for emergency exits.

Online data sheet



Technical Features

- Bolt operated with the cylinder and by operating the push-bar of the panic exit device from the inside (EMERGENCY function).
- Spring latch operated with the cylinder and with the 8 mm handle spindle (from the outside).
- Cylinder handle C/C distance 85 mm.
- Bolt with thickness of 10 mm and minimum protrusion of 24 mm.
- Spring latch with 10 mm protrusion.
- Flat front plate 24x3 mm.

Materials

- Lock cover plate and case plate in zinc plated steel
- Front in stainless steel
- Spring latch and bolts in nickel-plated steel
- Zinc plated steel cylinder fixing screw
- Lock fixing screws in stainless steel

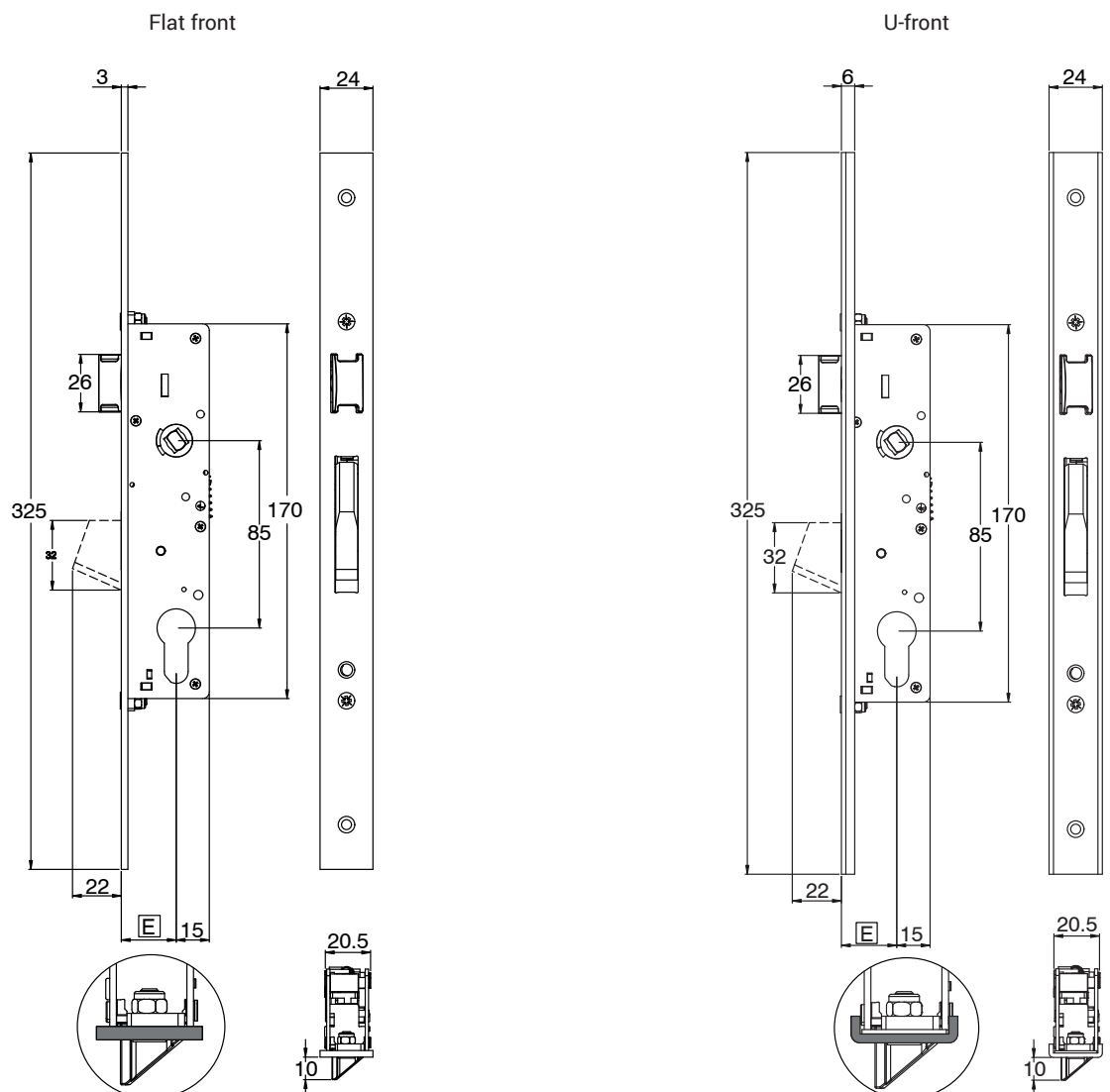

PANIC EXIT DEVICE AP100

Item code	Description	Backset E [mm]	Front width [mm]	Front type	Compatible counter-plates	Base Raw	Anodised Elox	Painted	Trend/Gold Brass	Pieces per pack
07640	CENTRAL LOCK FOR EMERGENCY EXITS	25	24	U-SHAPED	07691 - 07694 - 07695	X				1
07643	CENTRAL LOCK FOR EMERGENCY EXITS	25	24	PLATE	07690 - 07691 - 07692 - 07693 - 07694 - 07695	X				1
07660	CENTRAL LOCK FOR EMERGENCY EXITS	30	24	U-SHAPED	07691 - 07694 - 07695	X				1
07661	CENTRAL LOCK FOR EMERGENCY EXITS	35	24	U-SHAPED	07691 - 07694 - 07695	X				1
07662	CENTRAL LOCK FOR EMERGENCY EXITS	30	24	PLATE	07690 - 07691 - 07692 - 07693 - 07694 - 07695	X				1
07663	CENTRAL LOCK FOR EMERGENCY EXITS	35	24	PLATE	07690 - 07691 - 07692 - 07693 - 07694 - 07695	X				1

MULTIPOINT LOCKS FOR EMERGENCY EXITS



Functions

Multipoint lock with central lock and additional locks, available with flat front and "U" shaped front, equipped with spring latch and pivoting bolts for emergency exits.

Online data sheet



Technical Features

- Bolts operated with the cylinder and by operating the push-bar of the panic exit device from the inside (EMERGENCY function).
- Spring latch operated with the cylinder and with the 8 mm handle spindle (from the outside).
- Cylinder handle C/C distance 85 mm.
- Bolts with thickness of 10 mm and minimum protrusion of 24 mm.
- Spring latch with 10 mm protrusion.
- Front plate 24x3 mm.
- Available with U front and Flat front

Materials

- Lock cover plates and case plate in zinc plated steel
- Front in stainless steel
- Spring latch and bolts in nickel-plated steel
- Zinc plated steel cylinder fixing screw
- Lock fixing screws in stainless steel

Flat front

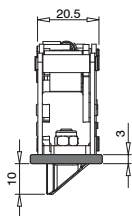

U-front

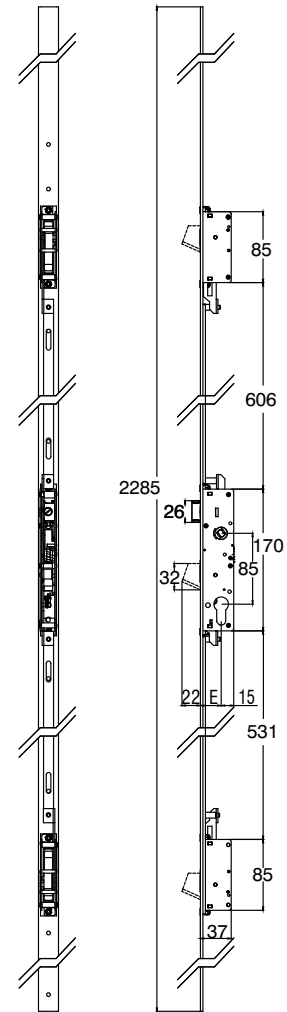
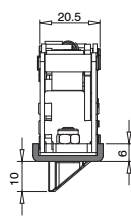

Item code	Description	Backset E [mm]	Front width [mm]	Front type	Compatible counter-plates	Base Raw	Anodised Elox	Painted	Trend/Gold Brass	Pieces per pack
07653	MULTIPOINT LOCK FOR EMERGENCY EXITS	25	24	PLATE	07700 - 07701 - 07702 - 07703 - 07704-07705	X				1
07664	MULTIPOINT LOCK FOR EMERGENCY EXITS	30	24	U-SHAPED	07701 - 07704 - 07705	X				1
07665	MULTIPOINT LOCK FOR EMERGENCY EXITS	35	24	U-SHAPED	07701 - 07704 - 07705	X				1
07666	MULTIPOINT LOCK FOR EMERGENCY EXITS	30	24	PLATE	07700 - 07701 - 07702 - 07703 - 07704-07705	X				1
07667	MULTIPOINT LOCK FOR EMERGENCY EXITS	35	24	PLATE	07700 - 07701 - 07702 - 07703 - 07704-07705	X				1

COUNTERPLATES FOR LOCKS AP100

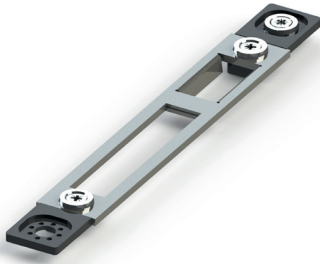

Functions

Counterplates to be combined with the central locks AP100 multi-point locks for emergency exits to be combined with the system.

Online data sheet



Technical Features

TYPE 1

Counterplate and set of adjustable counterplates for door profiles without a channel, to be combined with the single and multi-point locks for emergency AP100.

Front fixing with self-threading screws. Equipped with shims to adjust the stack.

Side adjustment ± 2 mm with the two blocks ready-assembled to the counterplate.

Materials

Front plates, screws for fixing to the profile and nuts made of stainless steel
Central plate body in zamak

TYPE 2

Counterplate and set of adjustable flat counterplates for door profiles without a channel, to be combined with the single and multi-point locks for emergency AP100.

Front fixing with self-tapping screws.

Side adjustment ± 1.5 mm with slots.

Materials

Counterplates and screws for fixing to the profile made of stainless steel

TYPE 3

Counterplate and set of adjustable counterplates for European Groove type profiles, to be combined with the single and multi-point locks for emergency AP100.

Front fixing in a channel by way of machined fixing plates, to lock in different positions to obtain adaptability to the various series of profiles.

Side adjustment ± 2 mm with slots.

Materials

Front plates, screws for fixing to the profile and nuts made of stainless steel
Adapters for side adjustment and machined fixing plates made of zamak

TYPE 4

Counterplate and set of adjustable counterplates for R40/R50 type profiles, to be combined with the single and multi-point locks for emergency AP100.

Front fixing in a channel by way of machined fixing plates, to lock in different positions to obtain adaptability to the various series of profiles.

Side adjustment ± 2 mm with slots.

Materials

Front plates, screws for fixing to the profile and nuts made of stainless steel
Adapters for side adjustment and machined fixing plates made of zamak

TYPE 5

Counterplate and set of adjustable counterplates for profiles with a channel with a stack of 30 mm, to be combined with the single and multi-point locks for emergency AP100.

Front fixing in a channel by way of machined fixing plates, to lock in different positions to obtain adaptability to the various series of profiles.

Side adjustment ± 2 mm with slots

Materials

Front plates, screws for fixing to the profile and nuts made of stainless steel
Adapters for side adjustment and machined fixing plates made of zamak

Type 1 – art. 07691

Type 1 – art. 07701

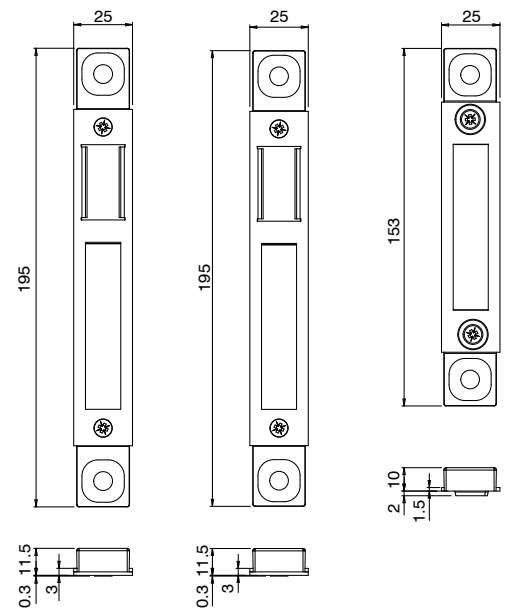

Type 2 – art. 07695

Type 3 – art. 07690

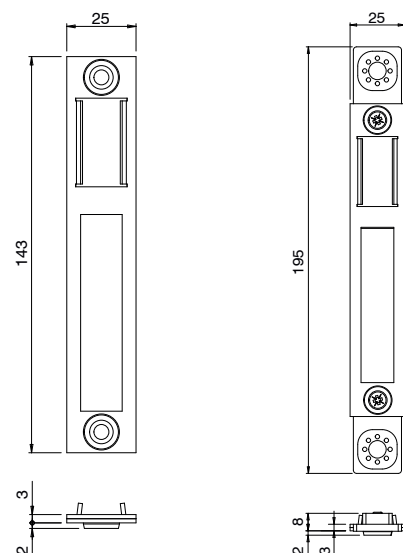

Type 3 – art. 07700

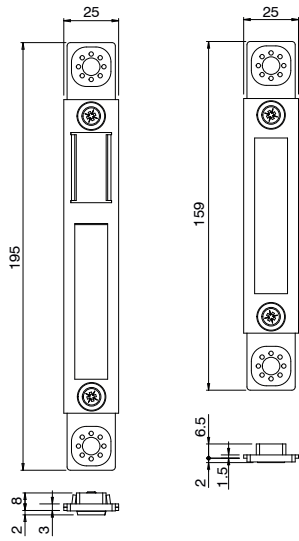

Type 3 – art. 07702

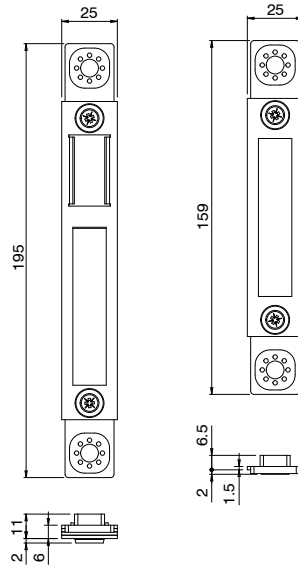

Type 4 – art. 07693

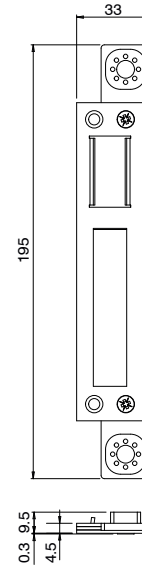

Type 5 – art. 07694

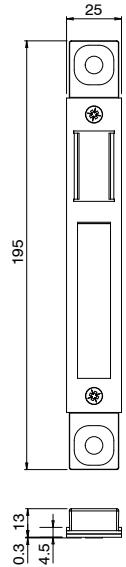

Item code	Description	Adjustment	Width [mm]	PROFILE CROSS - SECTION	Locks compatible with AP100	Base Raw	Anodised Elox	Painted	Trend/Gold Brass	Pieces per pack
07690	COUNTERPLATE FOR EUROPEAN GROOVE PROFILES	± 2 mm	25	C001-C013-C015	07643 - 07644 - 07645 - 07662 - 07663	X				1
07691	COUNTERPLATE FOR DOOR PROFILES	± 2 mm	25	C001-C002-C013-C014-C017	07641 - 07642 - 07644 - 07645 - 07660 - 07661 - 07662 - 07663	X				1
07693	COUNTERPLATE FOR PROFILE R40/R50	± 2 mm	33	C007-C008	07643 - 07644 - 07645 - 07662 - 07663	X				1
07694	COUNTERPLATE FOR PROFILES GROOVE 15/20 STACK >15	± 2 mm	25	-	07640 - 07641 - 07642 - 07643 - 07644 - 07645 - 07660 - 07661 - 07662 - 07663	X				1
07695	UNIVERSAL FLAT COUNTERPLATE	± 1.5 mm	25	-	07640 - 07641 - 07642 - 07643 - 07644 - 07645 - 07660 - 07661 - 07662 - 07663	X				1
07700	COUNTERPLATE KIT FOR EUROPEAN GROOVE PROFILES	± 2 mm	25	C001-C013-C015	07653 - 07654 - 07655	X				1
07701	COUNTERPLATE KIT FOR DOOR PROFILES	± 2 mm	25	-	07650 - 07651 - 07652 - 07653 - 07654 - 07655 - 07664 - 07665 - 07666 - 07667	X				1
07702	COUNTERPLATE KIT FOR PROFILES GROOVE 15/20 STACK 12/15	± 2 mm	25	C010	07653 - 07654 - 07655 - 07666 - 07667	X				1

PANIC EXIT DEVICE AP200



PANIC EXIT DEVICE AP200

Functions

TOUCH BAR type safety panic exit device for slip-on mounting.

Technical Features

The security version AP200 system consists of:

- AP200 Mechanism with integrated bar, available in two different lengths
- Antipanic security locks with one and three locking points, to be chosen depending on the profile and the type of application with specific counterplates
- Counterplates for AP200 locks

The pressure on the bar determines the rotation of a special square pin (emergency function) which operates the security lock coupled with the device only when opening.

The security locks of this type have the characteristic of being able to be opened by simply turning the handle spindle, even when the bolt is closed. The special conditions of installation make the emergency function active only on the inside of the door.

The mechanism, locks and emergency function can be easily reversed for application on both left and right handed doors.

The product is supplied with the fitting instructions, containing paper templates for machining the profile and the product maintenance manual.

Certifications

The AP200 system is certified to UNI EN 1125:2008 standards and approved for CE marking, with the highest performance levels.

The field of application of these panic exit devices, referring to this standard, is the following:

- maximum weight of the door 250 kg
- maximum height of the door 2500 mm
- maximum width of the door 1300 mm
- temperature limits -10°C/+60°C

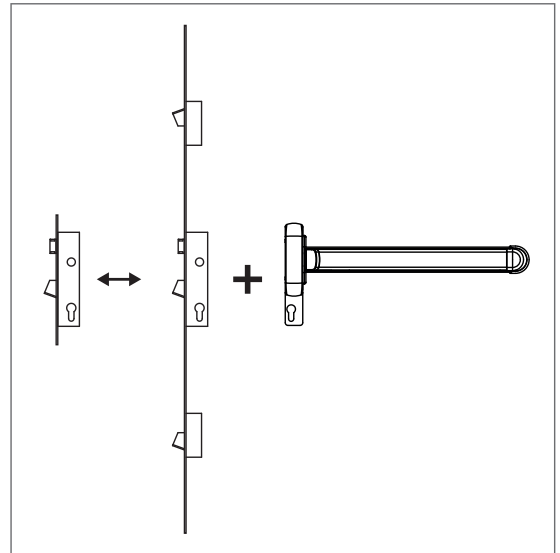

Configurations

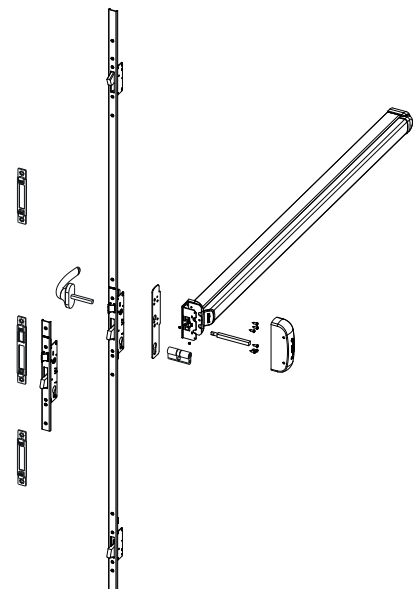
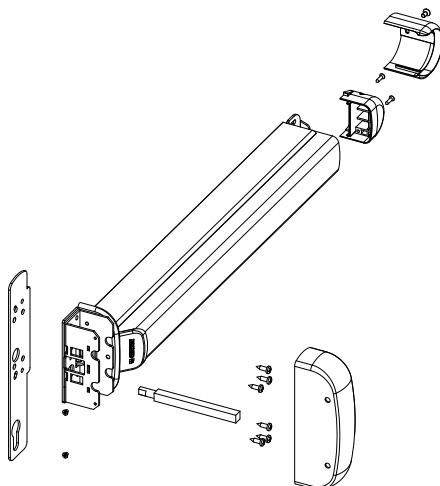
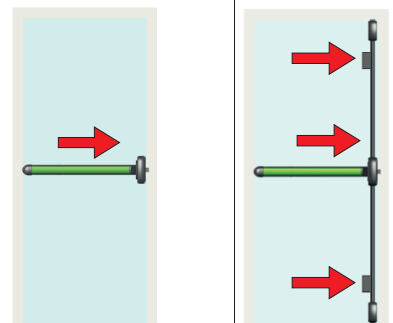

AP200 MECHANISM



Functions

TOUCH BAR type safety panic exit device for slip-on mounting.

Online data sheet



Technical Features

The AP200 mechanism consists of:

- the reversible mechanism (A) and its mechanism protection plug (B)
- the pre-assembled round coupling shim (C)
- the base with push-bar and mechanism (D), with assembled front and rear caps
- square connecting pin between the fastening mechanism and lock (E)
- the shimming plate (F)

The device to insert should be combined with the following components:

- the security locks with one-point and three-point fastening, to be chosen depending on the profile and the type of application with specific counterplates
- specific strikers for the lock used cylinder

Materials

- Mechanisms in zinc plated steel
- Painted steel mechanism protection plug
- Brackets in Zamak
- Shimming plates in zinc plated steel
- Grub screws and fixing screws in zinc plated steel

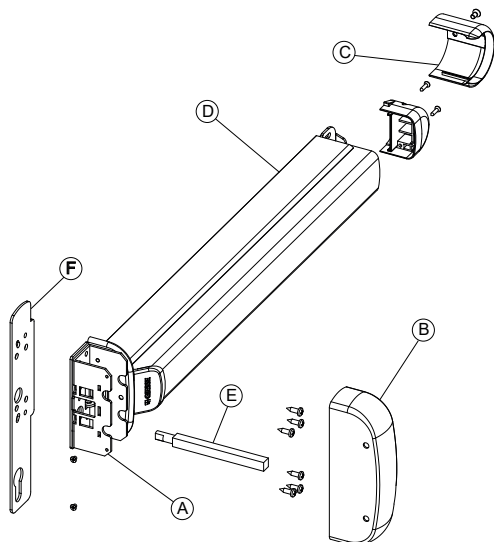

Item code	Description	Note	Base Raw	Anodised Elox	Painted	Trend/Gold Brass	Pieces per pack
07430	PANIC EXIT DEVICE AP200	L=1170			X		1
07431	PANIC EXIT DEVICE AP200	L=1300			X		1

CENTRAL LOCKS FOR EMERGENCY EXITS

Functions

Central lock, slip-on version for aluminium uprights, available with flat front and "U" shaped front, equipped with spring latch and pivoting bolt for emergency exits.

Online data sheet



Technical Features

Bolt operated with the cylinder and by operating the push-bar of the panic exit device from the inside (EMERGENCY function).

Spring latch operated with the cylinder and with the 8 mm handle spindle (from the outside).

Cylinder handle C/C distance 85 mm.

Bolt with thickness of 10 mm and minimum protrusion of 24 mm.

Spring latch with 10 mm protrusion.

Flat front plate 24x3 mm.

Materials

Lock cover plate and case plate in zinc plated steel

Front in stainless steel

Spring latch and bolts in nickel-plated steel

Zinc plated steel cylinder fixing screw

Lock fixing screws in stainless steel

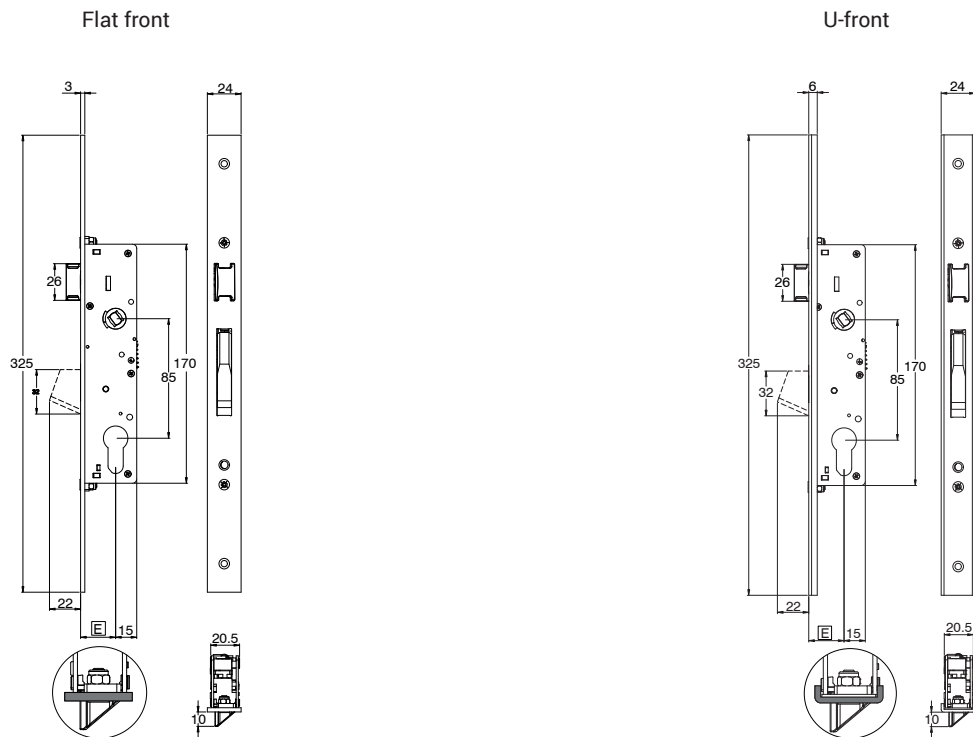

Item code	Description	Backset E [mm]	Front width [mm]	Front type	Compatible counter-plates	Base Raw	Anodised Elox	Painted	Trend/Gold Brass	Pieces per pack
07660	CENTRAL LOCK FOR EMERGENCY EXITS	30	24	U-SHAPED	07691 - 07694 - 07695	X				1
07661	CENTRAL LOCK FOR EMERGENCY EXITS	35	24	U-SHAPED	07691 - 07694 - 07695	X				1
07662	CENTRAL LOCK FOR EMERGENCY EXITS	30	24	PLATE	07690 - 07691 - 07692 - 07693 - 07694 - 07695	X				1
07663	CENTRAL LOCK FOR EMERGENCY EXITS	35	24	PLATE	07690 - 07691 - 07692 - 07693 - 07694 - 07695	X				1

MULTIPOINT LOCKS FOR EMERGENCY EXITS



Functions

Multipoint lock with central lock and additional locks, available with flat front and "U" shaped front, equipped with spring latch and pivoting bolts for emergency exits.

Online data sheet



Technical Features

- Bolts operated with the cylinder and by operating the push-bar of the panic exit device from the inside (EMERGENCY function).
- Spring latch operated with the cylinder and with the 8 mm handle spindle (from the outside).
- Cylinder handle C/C distance 85 mm.
- Bolts with thickness of 10 mm and minimum protrusion of 24 mm.
- Spring latch with 10 mm protrusion.
- Front plate 24x3 mm.
- Available with U front and Flat front

Materials

- Lock cover plates and case plate in zinc plated steel
- Front in stainless steel
- Spring latch and bolts in nickel-plated steel
- Zinc plated steel cylinder fixing screw
- Lock fixing screws in stainless steel

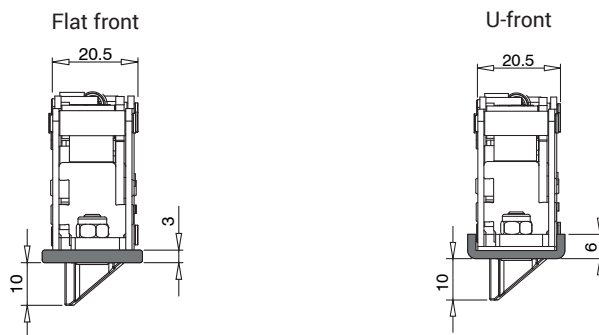
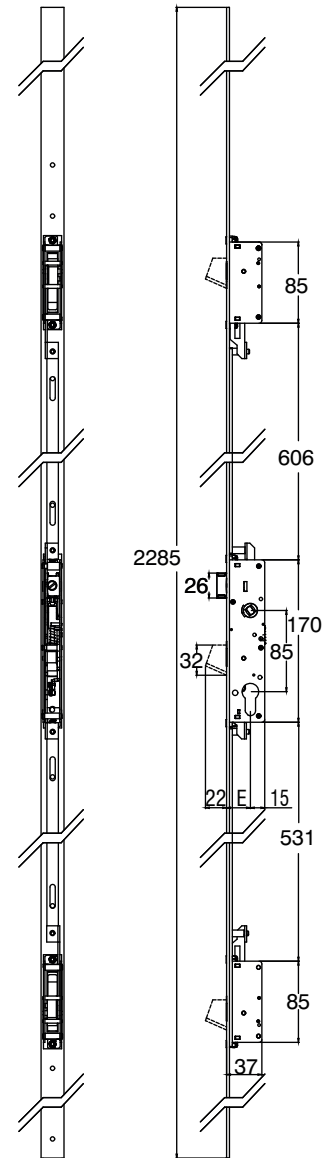

Item code	Description	Backset E [mm]	Front width [mm]	Front type	Compatible counter-plates	Base Raw	Anodised Elox	Painted	Trend/Gold Brass	Pieces per pack
07664	MULTIPOINT LOCK FOR EMERGENCY EXITS	30	24	U-SHAPED	07701 - 07704 - 07705	X				1
07665	MULTIPOINT LOCK FOR EMERGENCY EXITS	35	24	U-SHAPED	07701 - 07704 - 07705	X				1
07666	MULTIPOINT LOCK FOR EMERGENCY EXITS	30	24	PLATE	07700 - 07701 - 07702 - 07703 - 07704 - 07705	X				1
07667	MULTIPOINT LOCK FOR EMERGENCY EXITS	35	24	PLATE	07700 - 07701 - 07702 - 07703 - 07704 - 07705	X				1

COUNTERPLATES FOR LOCKS AP200

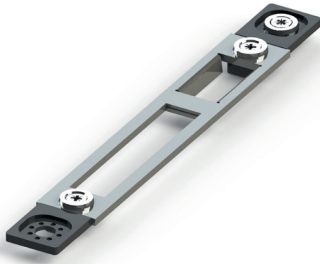

Functions

Counterplates to be combined with the central locks AP200 multi-point locks for emergency exits to be combined with the system.

Online data sheet



Technical Features

TYPE 1

Counterplate and set of adjustable counterplates for door profiles without a channel, to be combined with the single and multi-point locks for emergency AP200.

Front fixing with self-threading screws. Equipped with shims to adjust the stack.

Side adjustment ± 2 mm with the two blocks ready-assembled to the counterplate.

Materials

Front plates, screws for fixing to the profile and nuts made of stainless steel
Central plate body in zamak

TYPE 2

Counterplate and set of adjustable flat counterplates for door profiles without a channel, to be combined with the single and multi-point locks for emergency AP200.

Front fixing with self-tapping screws.

Side adjustment ± 1.5 mm with slots.

Materials

Counterplates and screws for fixing to the profile made of stainless steel

TYPE 3

Counterplate and set of adjustable counterplates for European Groove type profiles, to be combined with the single and multi-point locks for emergency AP200.

Front fixing in a channel by way of machined fixing plates, to lock in different positions to obtain adaptability to the various series of profiles.

Side adjustment ± 2 mm with slots.

Materials

Front plates, screws for fixing to the profile and nuts made of stainless steel
Adapters for side adjustment and machined fixing plates made of zamak

TYPE 4

Counterplate and set of adjustable counterplates for R40/R50 type profiles, to be combined with the single and multi-point locks for emergency AP200.

Front fixing in a channel by way of machined fixing plates, to lock in different positions to obtain adaptability to the various series of profiles.

Side adjustment ± 2 mm with slots.

Materials

Front plates, screws for fixing to the profile and nuts made of stainless steel
Adapters for side adjustment and machined fixing plates made of zamak

TYPE 5

Counterplate and set of adjustable counterplates for profiles with a channel with a stack of 30 mm, to be combined with the single and multi-point locks for emergency AP200.

Front fixing in a channel by way of machined fixing plates, to lock in different positions to obtain adaptability to the various series of profiles.

Side adjustment ± 2 mm with slots

Materials

Front plates, screws for fixing to the profile and nuts made of stainless steel
Adapters for side adjustment and machined fixing plates made of zamak

Type 1 – art. 07691

Type 1 – art. 07701

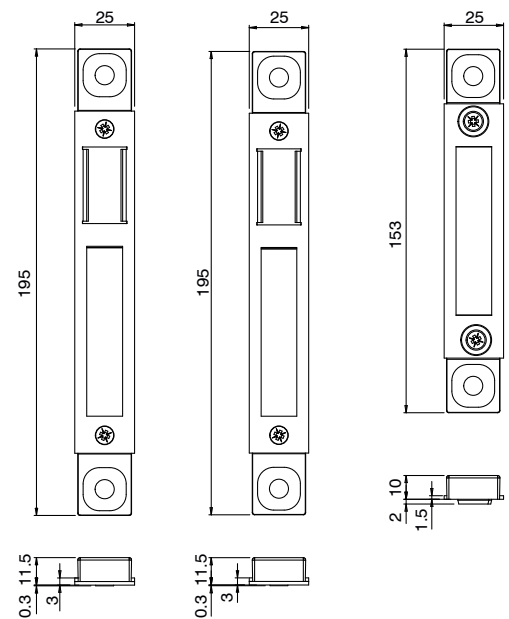

Type 2 – art. 07695

Type 3 – art. 07690

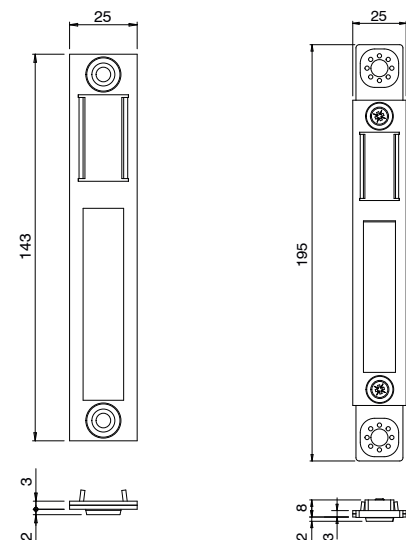

Type 3 – art. 07700

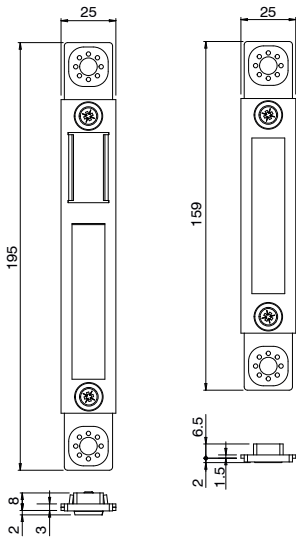

Type 3 – art. 07702

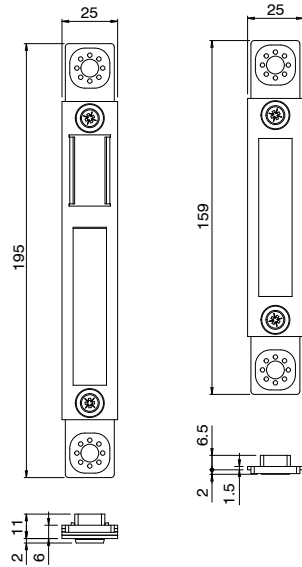

Type 4 – art. 07693

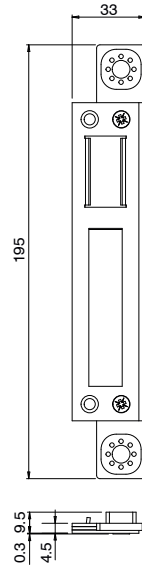

Type 5 – art. 07694

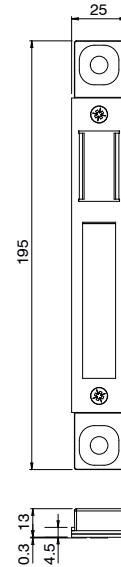

Type 5 – art. 07704

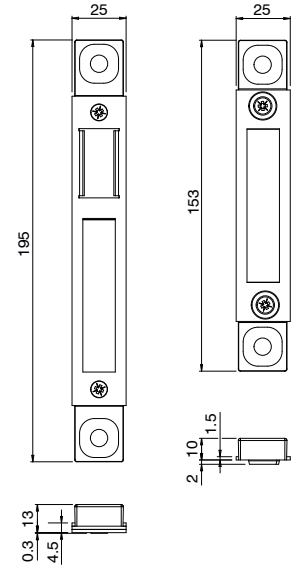

Item code	Description	Adjustment	Width [mm]	PROFILE CROSS - SECTION	Locks compatible with AP200	Base Raw	Anodised Elox	Painted	Trend/Gold Brass	Pieces per pack
07690	COUNTERPLATE FOR EUROPEAN GROOVE PROFILES	± 2 mm	25	C001-C013-C015	07644 - 07645 - 07662 - 07663	X				1
07691	COUNTERPLATE FOR DOOR PROFILES	± 2 mm	25	C001-C002-C013-C014-C017	07641 - 07642 - 07644 - 07645 - 07660 - 07661 - 07662 - 07663	X				1
07693	COUNTERPLATE FOR PROFILE R40/R50	± 2 mm	33	C007-C008	07644 - 07645 - 07662 - 07663	X				1
07694	COUNTERPLATE FOR PROFILES GROOVE 15/20 STACK >15	± 2 mm	25	-	07641 - 07642 - 07644 - 07645 - 07660 - 07661 - 07662 - 07663	X				1
07695	UNIVERSAL FLAT COUNTERPLATE	± 1.5 mm	25	-	07641 - 07642 - 07644 - 07645 - 07660 - 07661 - 07662 - 07663	X				1
07700	COUNTERPLATE KIT FOR EUROPEAN GROOVE PROFILES	± 2 mm	25	C001-C013-C015	07654 - 07655	X				1
07701	COUNTERPLATE KIT FOR DOOR PROFILES	± 2 mm	25	-	07651 - 07652 - 07654 - 07655 - 07664 - 07665 - 07666 - 07667	X				1
07702	COUNTERPLATE KIT FOR PROFILES GROOVE 15/20 STACK 12/15	± 2 mm	25	C010	07654 - 07655 - 07666 - 07667	X				1
07704	COUNTERPLATE KIT FOR PROFILES GROOVE 15/20 STACK >15	± 2 mm	25	-	07651 - 07652 - 07654 - 07655 - 07664 - 07665 - 07666 - 07667	X				1



SEALING AND FASTENING MECHANISM



SASH GIAP BOLTS

Functions

Polyamide bolt composed of an actuator and terminal with pin for direct fixing to the floor.
Ideal for side-hung doors and windows in aluminium with central gasket.

Online data sheet



Technical Features

For the fixing where mounting is required in conjunction with the rod strikers, you will have to engage the supplied polyamide adjustable bush on the pin to achieve a perfect coupling.

Fits to the profile groove without any machining. Once positioned, secures with a block by tightening the pre-assembled M5 grub screw, with a 2.5 mm Allen key.

The polyamide connection plate can be replaced by the series rod to extend the mechanism.

Materials

Basic parts in fibreglass loaded polyamide
Terminal pin of zinc-nickel plated steel
Fixing block in Zamak
Stainless steel grub screw

Type 1

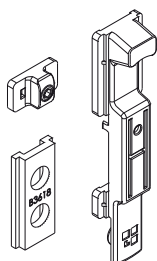

Type 3

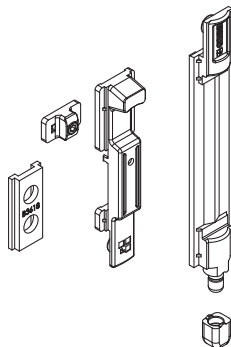

Type 4

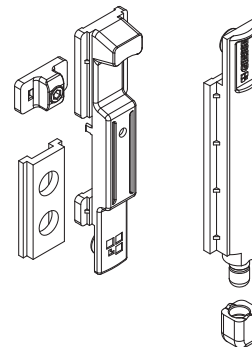

Type 5

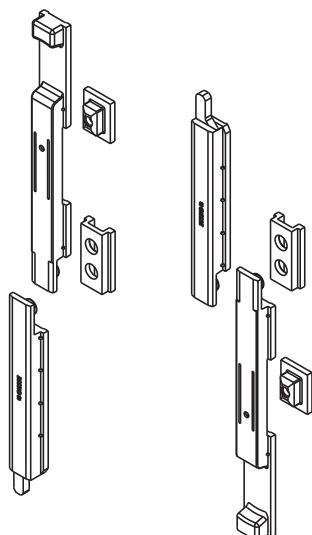

Type 6

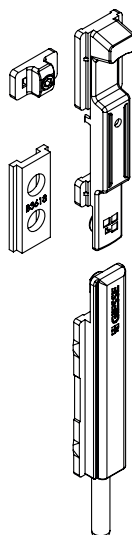

adjustment

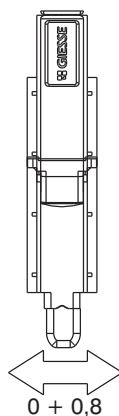

Item code	Description	Type	Groove (mm)	Adjustment (mm)	Discharged terminal	Offset terminal	Base Raw	Anodised Elox	Painted	Trend/Gold Brass	Pieces per pack
02108	GIAP BOLT	3	15 ÷ 20	+ 0,8	YES	-	X				50
02108K	GIAP BOLT	3	15 ÷ 20	+ 0,8	YES	-	X				50
02111K	GIAP BOLT	4	15 ÷ 20	+ 0,8	-	-	X				50
02111N	GIAP BOLT	4	15 ÷ 20	+ 0,8	-	-	X				50
02112	GIAP BOLT	4	13,2 ÷ 16,8	+ 0,8	-	-	X				50
02112K	GIAP BOLT	4	13,2 ÷ 16,8	+ 0,8	-	-	X				50
02125	GIAP BOLT	4	14 ÷ 18	+ 0,8	-	-	X				50
02125K	GIAP BOLT	4	14 ÷ 18	+ 0,8	-	-	X				50
02131	GIAP BOLT	5	15 ÷ 18	-	-	-	X				25
02131K	GIAP BOLT	5	15 ÷ 18	-	-	-	X				25
02132	GIAP BOLT	5	20 ÷ 23	-	-	-	X				25
02133	GIAP BOLT	4	23,6 ÷ 31	+ 0,8	-	-	X				50
02134	GIAP BOLT	5	20 ÷ 23	-	-	-	X				25
02138K	GIAP BOLT	3	13,2 ÷ 16,8	+ 0,8	YES	-	X				50
02164	GIAP BOLT	6	15 ÷ 20	-	-	YES	X				25
02165	GIAP MECHANISM	1	15 ÷ 20	-	-	-	X				50
02165K	GIAP MECHANISM	1	15 ÷ 20	-	-	-	X				50

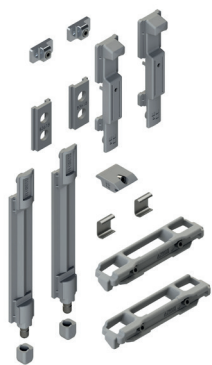

GIAP BOLT SECONDARY SASH KIT

Functions

Secondary sash fastening mechanism with Giap bolt.
For use on the single casement of side hung windows.

Online data sheet



Technical Features

The fastening mechanism is composed of two Giap bolts, closing strikers and a raising element.

The fastening mechanism is to be in addition to the Flash Base hinges.

Materials

Connecting blocks and raiser made of polyamide

Bolt tip and terminal bushing in polyamide

Plug in zamak

Double striker in zamak with GS Silver Plus finish
(over 500 hours of corrosion resistance)

Insert for striker and grub screws in stainless steel

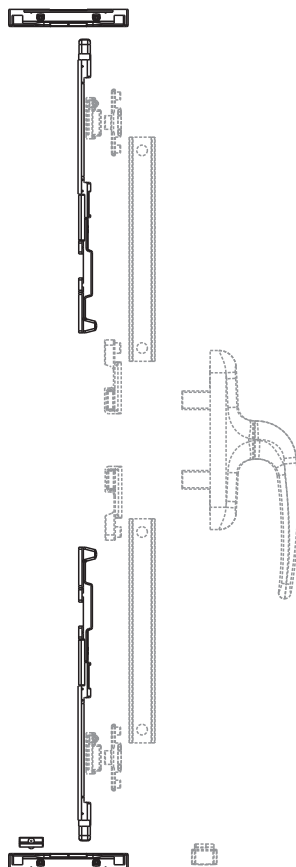

Item code	Description	PROFILE CROSS - SECTION	Sash kit match	Base Raw	Anodised Elbox	Painted	Trend/Gold Brass	Pieces per pack
02581K	KIT FOR SECONDARY SASH WITH GIAP BOLT	C001-C003-C005	02571K 02574K 02577K	X				10
02582K	KIT FOR SECONDARY SASH WITH GIAP BOLT	C002	02571K 02574K 02577K	X				10

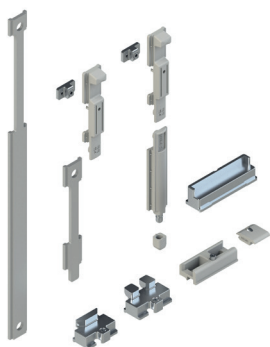

TILT-AND-TURN WINDOW GIAP BOLTS

Functions

Bolt for Giesse tilt-and-turn secondary sash featuring polyamide terminals with eccentric pin that enables sash closing compression adjustment.

Online data sheet



Technical Features

The bolt consists of a top and bottom bolt specially sized to be able to accommodate the closing (Upper) and anti-fall (Lower) strikers. It is fitted in the profile groove without machining and, after obtaining the correct positioning, fixed by tightening the grub screw pre-assembled on the fixing block. The supplied connecting plate can be replaced by the Giesse connection rod if the mechanism is to be sited in a non-standard position.

Materials

Extension in aluminium
 Bolt mechanism, connecting element, terminal bush, upper and lower terminals in polyamide
 Fixing plug in zamak
 Screws and grub screws in stainless steel

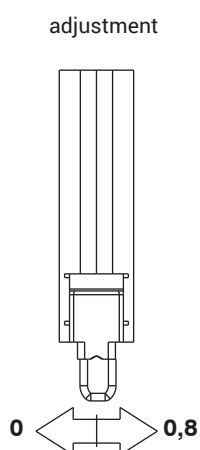

Item code	Description	PROFILE CROSS - SECTION	Groove (mm)	Adjustment (mm)	Base Raw	Anodised Elox	Painted	Trend/Gold Brass	Pieces per pack
0426001	T/T SECONDARY SASH GIAP BOLT	C010	15 ÷ 20	+ 0,8	X				10
04265K	T/T SECONDARY SASH GIAP BOLT	C007	15 ÷ 18	-	X				10
04266	T/T SECONDARY SASH GIAP BOLT	C008	20 ÷ 23	-	X				10
04267	T/T SECONDARY SASH GIAP BOLT	C009	15 ÷ 20	-	X				10
04274K	T/T SECONDARY SASH GIAP BOLT	C001-C003-C010-C011-C012-C015-C017	15 ÷ 20	+ 0,8	X				10
04277K	T/T SECONDARY SASH GIAP BOLT	C005	14 ÷ 18	+ 0,8	X				10
04278K	T/T SECONDARY SASH GIAP BOLT	C002-C014-C017	13,5 ÷ 16,8	+ 0,8	X				10



SUPERGIAP BOLTS

Functions

Direct activation bolt, especially strong, for aluminium casement window and door fixtures with central gasket seal.

Supplied in pairs.

For 20 mm groove.

[Online data sheet](#)



Technical Features

The bolt stroke is 18 mm.

Fits to the profile groove without any machining.

Once positioned, it secures with a block by tightening the pre-assembled M5 grub screw, with a 2.5 mm Allen key.

The terminal is equipped with a polyamide positioning spring.

The spring also has the feature of aiding the sliding and compensating for any extrusion tolerances or increased thickness due to painting.

The plate can be replaced by the connection rod.

Materials

Terminal pin of zinc plated steel.

Bolt tip body in zamak.

Pull recess, plate and spring in polyamide.

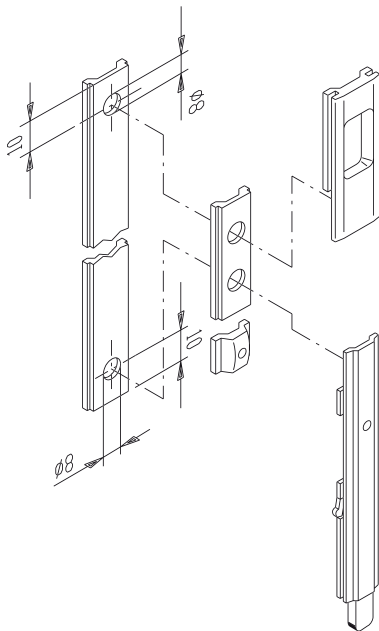

Item code	Description	Note	Base Raw	Anodised Elox	Painted	Trend/Gold Brass	Pieces per pack
02153	SUPERGIAP BOLT		X				10

GIAP AND SUPERGIAP ACCESSORIES

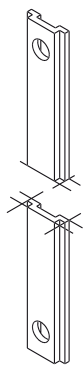

Functions

Rod to extend the GIAP bolt for 15-20 grooves.
The rod is used to extend the mechanism of the Giap bolt, instead of the connection plate.

Online data sheet



Materials

Fibreglass-reinforced polyamide

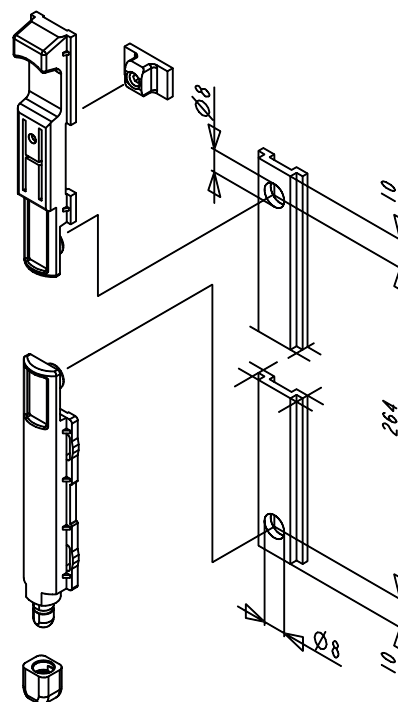

Item code	Description	Note	Base Raw	Anodised Elox	Painted	Trend/Gold Brass	Pieces per pack
02113	EXTENSION ROD FOR GIAP BOLTS	E.G. - ALLC05		X			50



ADJUSTABLE BOLTS

Functions

Bolt for second sash, featuring zamak terminals that enable secondary sash closing compression adjustment.

Online data sheet



Technical Features

Specifically designed for use on overlap profiles with double channel. It is fitted in the profile groove without machining and, after obtaining the correct positioning, fixed by tightening the grub screw pre-assembled on the fixing block.

The terminal is entirely in zamak and has a zamak bolt tip enabling ± 1.5 mm adjustment in the closed position.

The supplied connecting plate can be replaced by the GIESSE o series connecting bracket if the mechanism is to be sited in a non-standard position. The body of the terminal is equipped with vibration-damping leaf springs.

Adjustment

For adjustment, using a 2.5 mm Allen key just slacken the screw holding the terminal and bolt tip together, turn the bolt tip one or more steps in the required direction, then tighten the screw. Every step corresponds to a recovery of approx. 0.3 mm.

Materials

Mechanism and connecting element in polyamide. Terminal and fixing plug in stainless steel or zamak depending on the model.

Screws and grub screws in stainless steel.

Article 02168K - 02166K

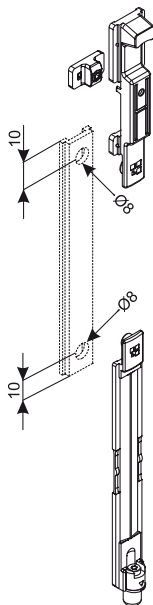

Article 04347

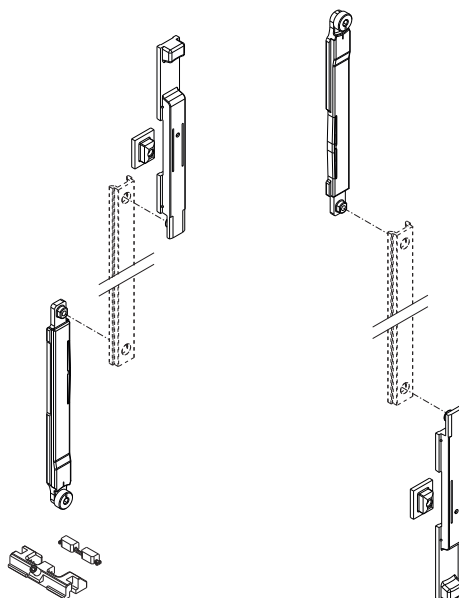

Adjustment Article 02168K - 02166K

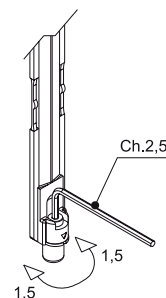

Adjustment Article 04347

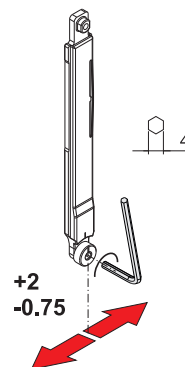

Item code	Description	PROFILE CROSS - SECTION	Groove (mm)	Terminal	Base Raw	Anodised Elox	Painted	Trend/Gold Brass	Pieces per pack
02166K	FUTURA ADJUSTABLE BOLT	-	13,2 ÷ 16,8	Zamak	X				10
02168K	FUTURA ADJUSTABLE BOLT	-	15 ÷ 20	Zamak	X				10
04347	ERRE - ADJUSTABLE BOLT	-	15 ÷ 18	Zamak	X				10

ADJUSTABLE BOLT SECONDARY SASH KIT

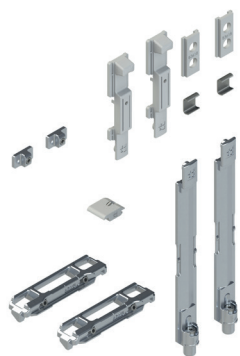

Functions

Secondary sash fastening mechanism with adjustable bolt.
For use on the single casement of side hung windows.

Online data sheet



Technical Features

The fastening mechanism is composed of two adjustable bolts, two closing strikers and a raising element.

The fastening mechanism is to be in addition to the Flash Base hinges.

Materials

Connecting blocks, raiser and mechanism made of polyamide

Plug, terminal and strikers in zamak with GS Silver Plus finish (up to 500 h of corrosion resistance)

Insert for strikers and grub screws in stainless steel

One-way bolt

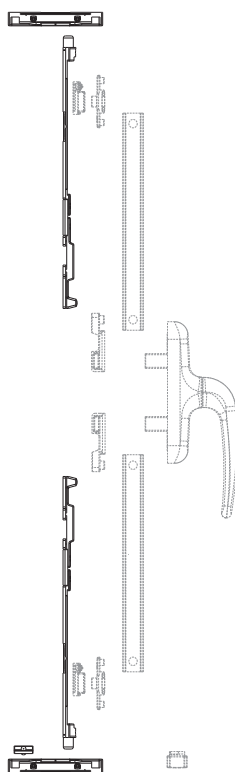

Two-way bolt

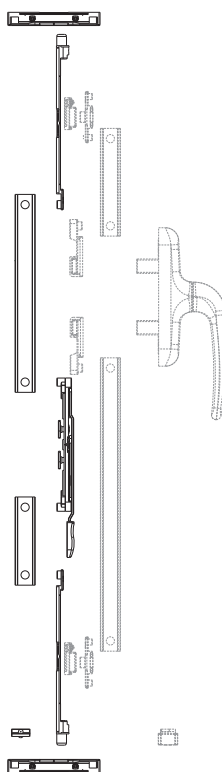

Adjustment

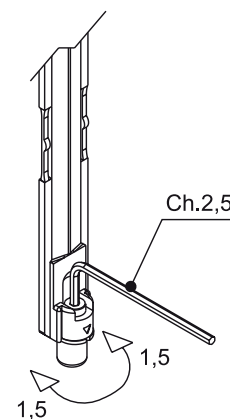

Item code	Description	PROFILE CROSS - SECTION	Sash kit match	Mechanism	Base Raw	Anodised Elox	Painted	Trend/Gold Brass	Pieces per pack
02585K	KIT FOR SECONDARY SASH-ADJUSTABLE BOLT	-	02571K - 02574K - 02577K	One-way	X				10

TWO-WAY BOLTS



Functions

Two-way lever bolt with mechanism enabling the closing of both terminals at the same time.

Online data sheet



Technical Features

The bolt is composed of a lever-operated mechanism that transmits two-way movement to the connecting brackets, the ends of which are fitted to the terminals with the adjustable bolt tip. Specifically designed for use on overlap profiles with double channel. The mechanism is fixed by means of a specific element with two grub screws for clamp fixing and hence without having to machine the profile. The body has two vibration-damping appendices. Adjustment
The terminals are provided with a bolt tip enabling 1.5 mm adjustment in the closed position.

Materials

Mechanism body, terminal and bolt tip in zamak with GS Silver Plus finish (over 500 hours of corrosion resistance). Terminal and bolt tip article 02011 in stainless steel. Mechanism lever and connecting bracket in stainless steel. Lever cover in polyamide. Screws and grub screws in stainless steel.

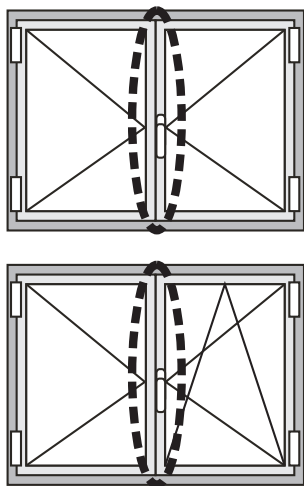

Type 1

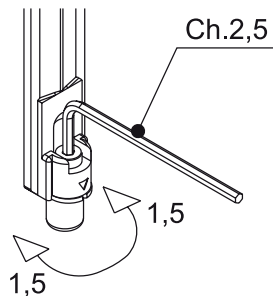

Type 2

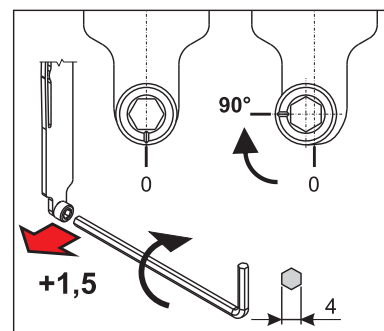

Type 3

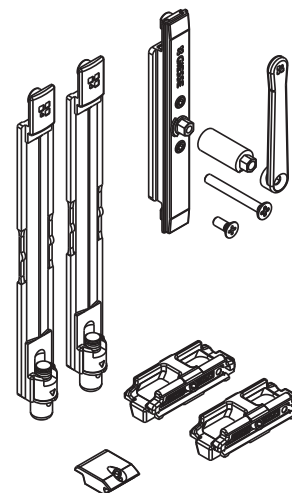
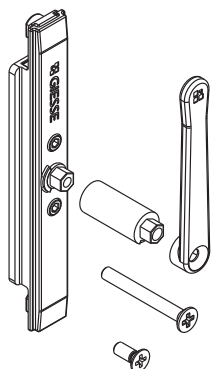
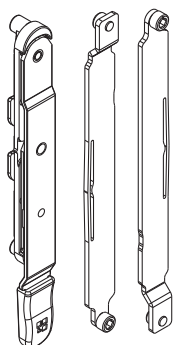

Type 4



Type 5

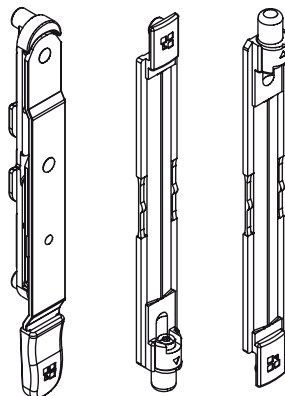

Item code	Description	PROFILE CROSS - SECTION	Type	Groove (mm)	Adjustment (mm)	Base Raw	Anodised Elox	Painted	Trend/Gold Brass	Pieces per pack
02011	FUTURA TWO-WAY BOLT	C002	1	13,2 - 16,8	+ 1,5	X				10
02156	TWO-WAY MECHANISM	-	2	-	-	X				10
02178	FUTURA TWO-WAY BOLT	-	3	15 - 20	± 1.5	X				10
02189K	TWO-WAY LEVER MECHANISM	-	4	-	-	X				20
02191K	FUTURA TWO-WAY BOLT	-	5	15 - 20	± 1.5	X				10
02195K	FUTURA TWO-WAY BOLT	-	5	13,2 - 16,8	± 1.5	X				10
04231	TWO-WAY LEVER BOLT	C007	1	15 - 18	+ 2/-0.75	X				10

PERIMETRAL CLOSING

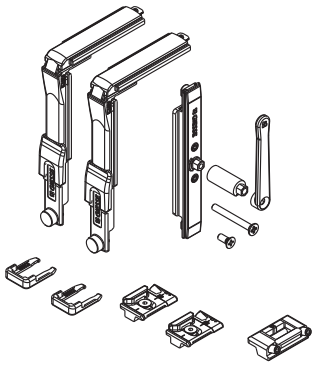

Functions

Provides perimeter locking of the secondary sash on the frame top and bottom cross beams.

It can be used both on double casement windows (additional profile) with double channel size 15/20 mm and inside the overlap, on the sash profile on which the overlap is fitted.

Online data sheet



Technical Features

The perimetral closing is composed of a two-way lever mechanism (which has an extension in case the hardware slides under the overlap profile), two Futura corner drives, two adjustable locking strikers and a raiser.

The mechanism is fixed with the contrast grub screws on the profile. This device enables fully closing the secondary sash, while also being able to increase the number of points by adding closing pawls and their strikers onto the polyamide rod that joins with the corner drives.

Materials

Corner drive, closing striker, mechanism, extension and lever in GS Silver Plus zamak
Sash-raiser striker made of polyamide
Screws and grub screws in steel

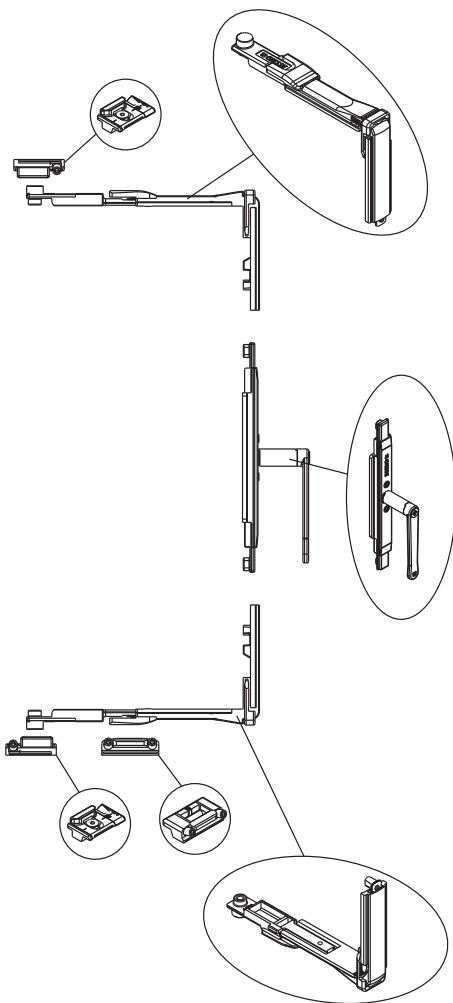

Adjustments

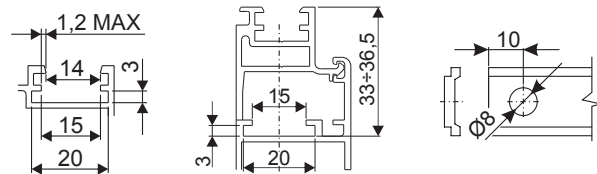
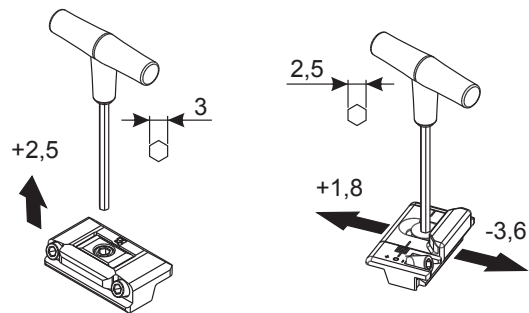

Item code	Description	Groove (mm)	Adjustment (mm)	Base Raw	Anodised Elox	Painted	Trend/Gold Brass	Pieces per pack
02179	PERIMETRAL TWO-WAY FASTENING MECHANISM	15 ÷ 20	+ 1.8 / - 3.6	X				10

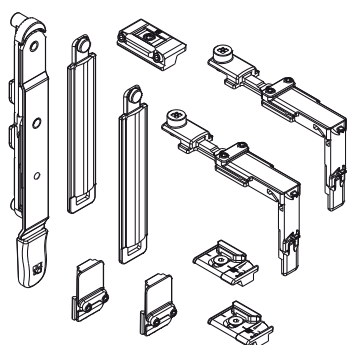

PERIMETRAL FASTENING MECHANISM FOR FUTURA SECONDARY SASH

Functions

Provides perimeter locking of the secondary sash on the frame top and bottom cross beams. For use on secondary sashes (additional profiles) with double channel of dimensions 15 to 20 mm.

Online data sheet



Technical Features

The perimetral closing for secondary sash consists of a two-way lever mechanism, two corner bolts and respective strikers. This product enables total fastening of the secondary sash with the creation of several locking points (two standard with the possibility of creating as many as necessary, adding pawls on the connection rod and locking strikers on the frame) on the frame cross beams.

Materials

Connection rods, corner drive and closing striker made of zamak
 Mechanism body made of zamak
 Mechanism lever and connecting bracket in steel
 Cover for lever and lifter striker made of polyamide
 Screws and grub screws in steel

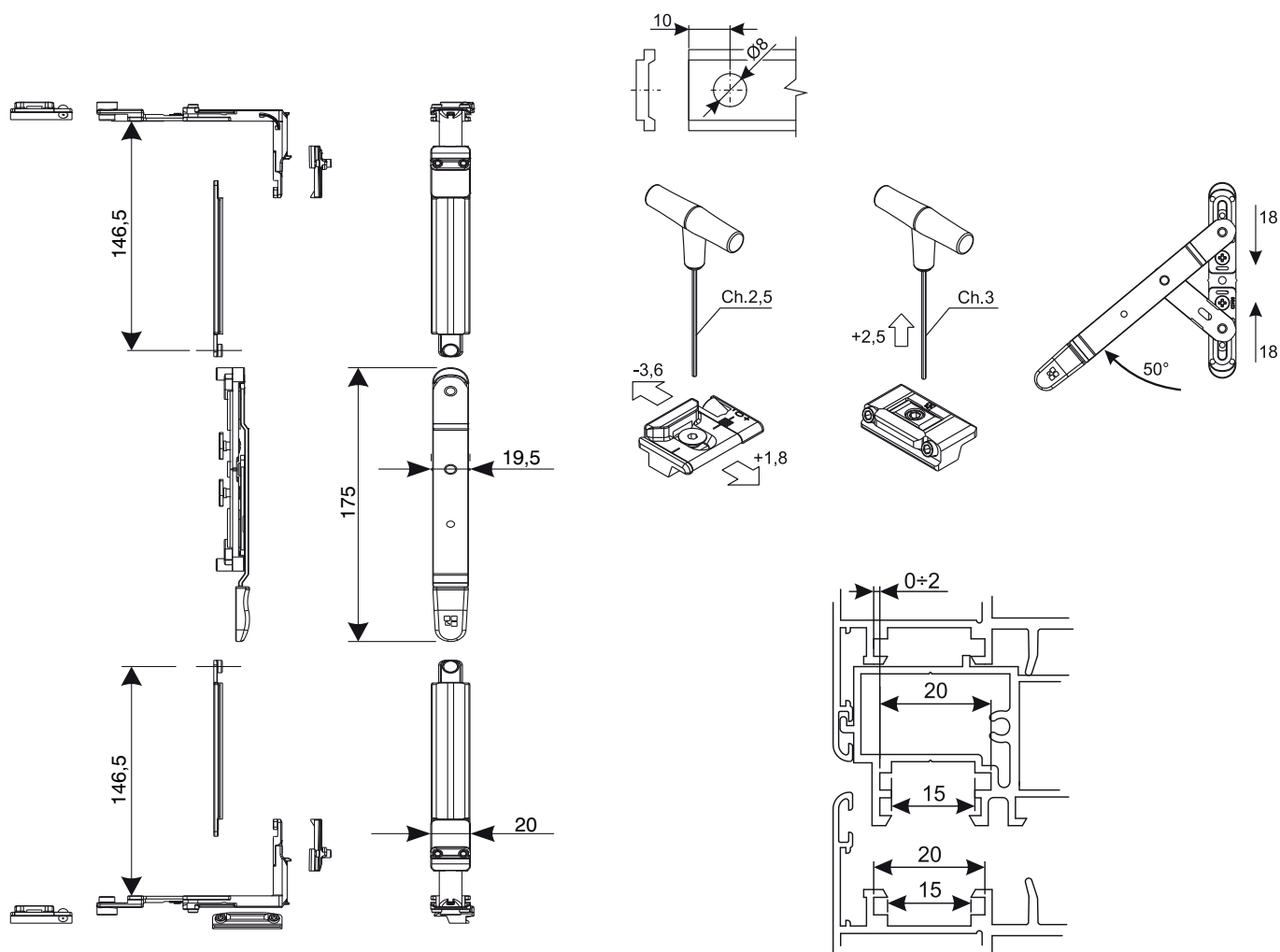

Item code	Description	Note	Base Raw	Anodised Elox	Painted	Trend/Gold Brass	Pieces per pack
02186K	PERIMETRAL FASTENING MECHANISM FOR FUTURA SECONDARY SASH	silver plus	X				10

FUTURA CORNER BOLT

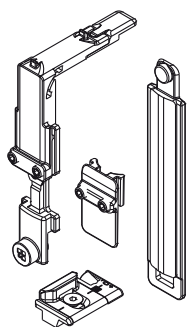

Functions

Corner bolt enabling the locking of secondary sashes on the top and bottom cross beams of the frame. For use on secondary sashes (additional profiles) with double channel of dimensions 15/20 mm (bottom channel).

Online data sheet



Technical Features

The bolt is equipped with an adjustable striker which allows a compression adjustment of ± 1.8 mm. The application requires the beat continuity plugs to be appropriately unloaded in order to allow the hardware to pass on the top and bottom cross beams.

Materials

Corner drive, connection rod, locking striker, drive clip in zamak GS PLUS SILVER (OVER 500h corrosion resistance)
Screws and grub screws in stainless steel

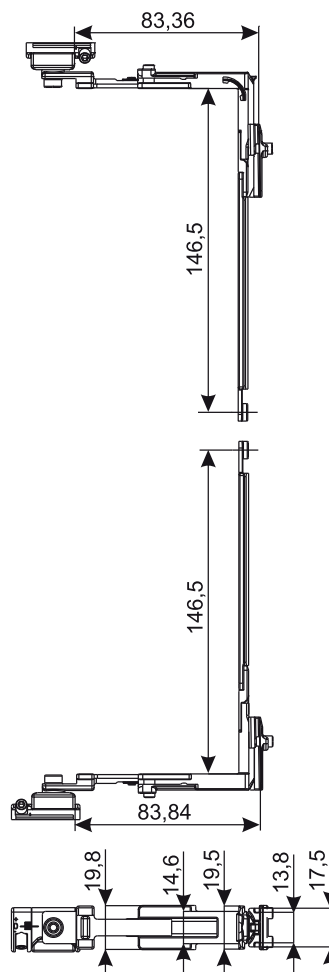
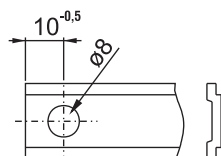
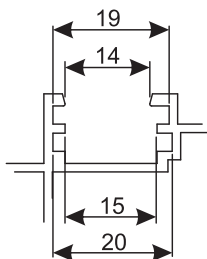
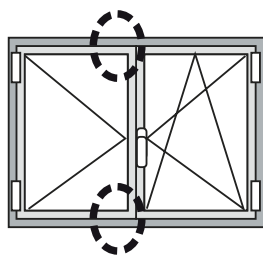
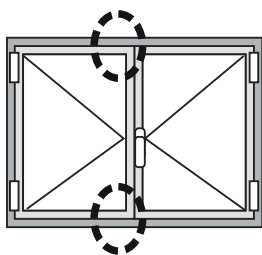

Item code	Description	Note	Base Raw	Anodised Elox	Painted	Trend/Gold Brass	Pieces per pack
04045K	FUTURA CORNER BOLT	silver plus	X				10

INCA BOLTS



Functions

Bolt for tilt-and-turn secondary sash featuring zamak terminals equipped with adjustable lock strikers for the pawls of the corner drive and of the bolt tip of the tilt-and-turn window.

Online data sheet



Technical Features

The strikers supplied enable the same adjustment of ± 2.4 mm. Specifically designed for use on assembled profiles with a single channel, although also compatible with double channel profiles. The two terminals are equipped with a steel bolt tip that can be combined with an eccentric bushing for closing position adjustment.

Materials

Terminal, bolt tip and fixing block in GS Silver Plus zamak. Connection rod and bolt tip in polyamide. Mounting grubscrew for bolt and bolt tip in zinc plated steel.

Assembly and adjustment

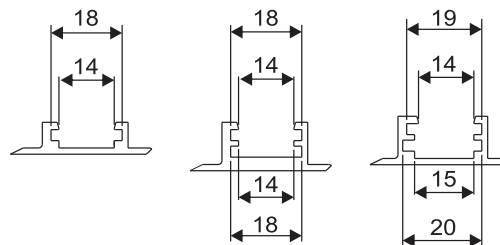
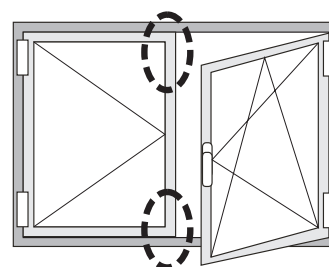
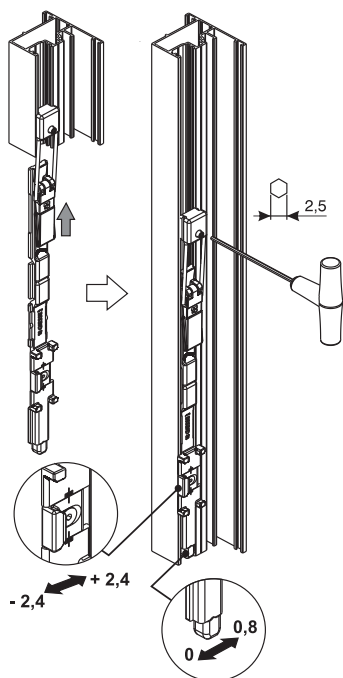

Item code	Description	Note	Base Raw	Anodised Elox	Painted	Trend/Gold Brass	Pieces per pack
04280	INCA BOLT		X				5
04282K	T/T FUTURA SECONDARY SASH BOLT	E.G. - frame 14/18 - silver plus	X				5

TOTEM BOLTS

Functions

One-way lever bolt to mount in a channel, indicated in doors made with window profile.

Online data sheet



Technical Features

Bolt suited for mounting on doors for frequent use (use category 4 - very heavy duty use - In compliance with EN12051: 1999).

Reversible it is applied both at the top and at the bottom of the door.

Bolt tip with cut-proof characteristics, in order to ensure a great hold on the strikers and high break-in security.

Bolt tip stroke 21 mm.

Compression adjustment +0.6 mm on the strikers with the eccentric bush provided (except on the version for groove 15x18).

Fixing to the profile with the two pre-assembled fixing grub screws, without any machining on the profile.

It is possible to extend the bolt by using the specific rod in the series, positioned between the connecting element and the terminal.

Mechanisms and bolt tips can also be ordered separately so as to allow different combinations.

Materials

- Operating base and element for connecting to the bolt tip made of zamak
- Zamak operating lever with polished chrome (high corrosion resistance)
- Spring, connecting brackets, pins and fixing grub screws made of stainless steel
- Bolt tip made of cut-proof carbonitrided steel with Giesse Silver Plus finish (up to 500 h corrosion resistance)
- Terminal, connecting block, bolt tip cap eccentric bush and "Z" blocks made of polyamide

Scheme for art. 02075
Dimensions of mechanism and bolt tip

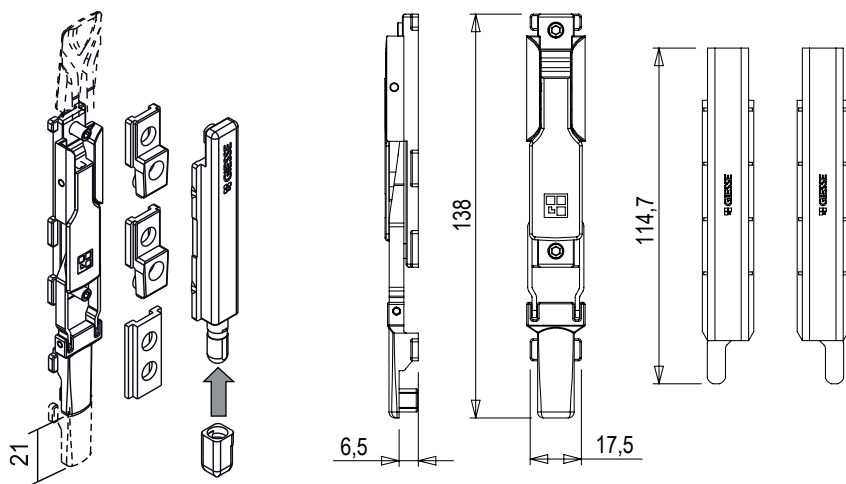

Scheme for art. 02071-02072-02073-02074
Dimensions of mechanism and bolt tip

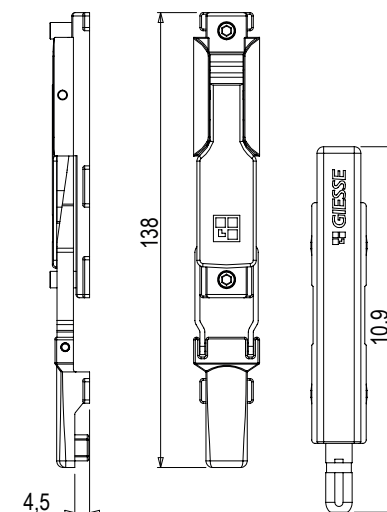

Sect. 1 - Groove 13.5x16.7

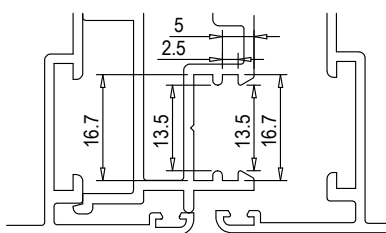

Sect. 2 - Groove 14x19

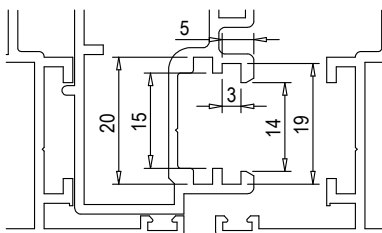

Sect. 3 - Groove 15x20

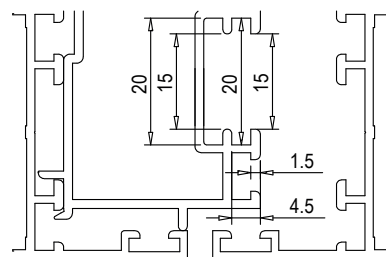

Sect. 4 - Groove 14x18

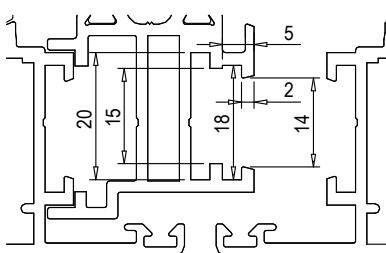

Sect. 5 - Groove 15x18

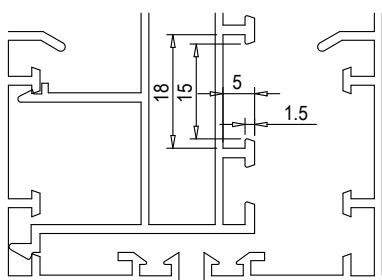

Item code	Description	Groove	Adjustment	Offset terminal	Dimensions bolt tip	Drawing	Base Raw	Anodised Elox	Painted	Trend/Gold Brass	Pieces per pack
02071	TOTEM BOLT	13.5x16.7	+ 0.6 mm	NO	Ø 8 mm	sect.1			X		10
02072	TOTEM BOLT	14x19	+ 0.6 mm	NO	Ø 8 mm	sect.2			X		10
02073	TOTEM BOLT	15x20	+ 0.6 mm	NO	Ø 8 mm	sect.3			X		10
02074	TOTEM BOLT	14x18	+ 0.6 mm	NO	Ø 8 mm	sect.4			X		10
02075	TOTEM BOLT	15x18	-	YES	4x6 mm	sect.5			X		5
02177K	TOTEM BOLT	14x18	+ 0.8 mm	NO	Ø 6 mm	sect.4	X				10

TOTEM MECHANISMS

Functions

Zamak lever mechanism to be combined with Giese fastening mechanism terminals.

Online data sheet

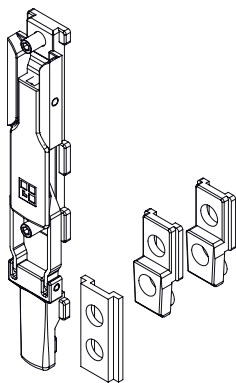

Technical Features

Reversible mechanism suitable for application on doors for frequent use, to be applied in a channel both at the top and at the bottom of the door.

Can be combined with the corresponding terminals using the connecting block supplied with the mechanism or with the specific rod in the series, cut to the desired size for the bolt extension.

Fixing to the profile with the pre-assembled fixing grub screws, without any machining on the profile.

Materials

- Operating base and element for connecting to the bolt tip made of zamak
- Zamak operating lever with polished chrome (high corrosion resistance)
- Spring, connecting brackets, pins and fixing grub screws made of stainless steel
- Connecting block and "Z" blocks made of polyamide

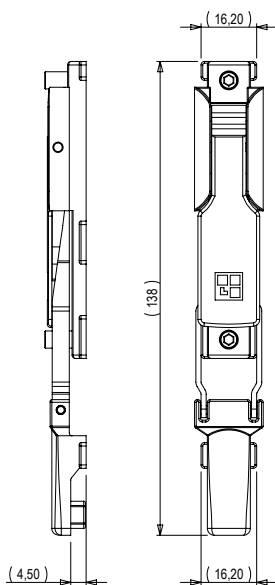

Sect. 2 - Groove 14x19

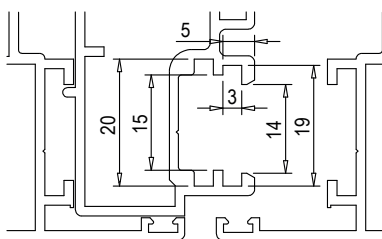

Sect. 3 - Groove 15x20

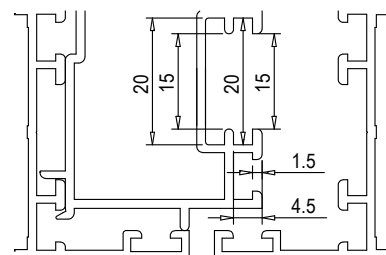

Sect. 4 - Groove 14x18

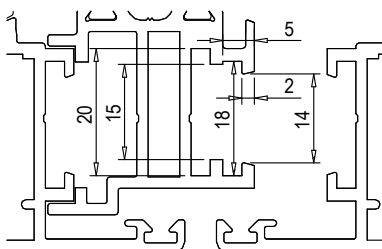

Sect. 5 - Groove 15x18

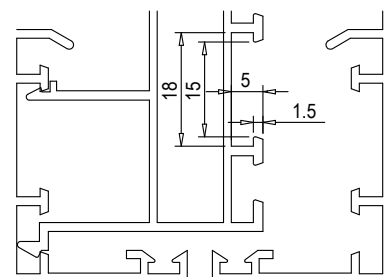

Item code	Description	Groove	Drawing	Base Raw	Anodised Elox	Painted	Trent/Gold Brass	Pieces per pack
02742	TOTEM MECHANISM	14x19	sect.2			X		10
02743	TOTEM MECHANISM	15x20	sect.3			X		10
02744	TOTEM MECHANISM	14x18	sect.4			X		10
02745	TOTEM MECHANISM	15x18	sect.5			X		10

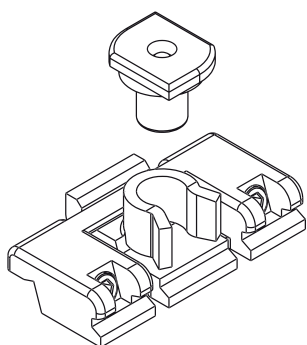

SASH STOP

Functions

The sash stop is fitted on sash casements of central gasket aluminium frames with the function of keeping the sash locked in the closed position. The casement can be unlocked by simply pressing on the casement. Invaluable for French windows and balcony doors.

Online data sheet



Technical Features

The sash stop is fitted by clamping in the profile channels, therefore very simple and fast because there is no machining. Fitting is possible also at a later time, at the discretion of the window maker or customer.

With the holding device activated the sash can be opened or closed by applying manual pressure without having to operate a release device.

Highly recommended for French windows (often without locks operated from the outside) which require locking on closing (after exiting) to avoid loss of warm or conditioned air to the outside.

Materials

Striker and pin in fibreglass loaded polyamide
 Polyamide spring
 Stainless steel grub screws

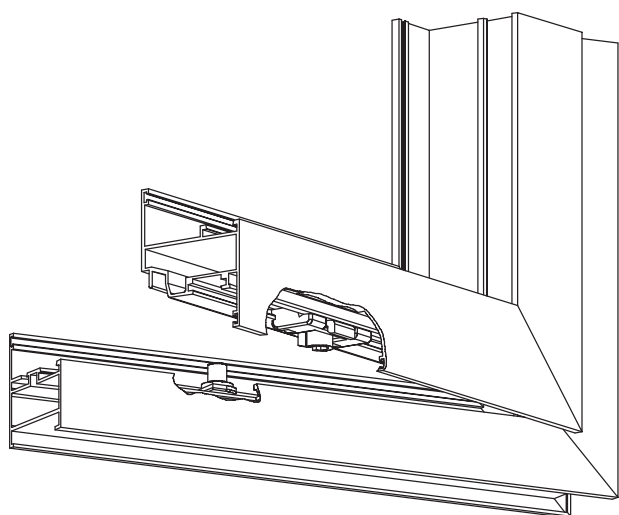

Item code	Description	PROFILE CROSS - SECTION	Colour	Base Raw	Anodised Elox	Painted	Trend/Gold Brass	Pieces per pack
02198	SASH STOP	C007-C008	Black	X				50
02199	SASH STOP	C001-C002-C004-C011-C012-C013-C014-C015-C016-C017	Black	X				50

MAYA BOLTS

Functions

One-way lever bolt with reduced size for door profile.

[Online data sheet](#)



Technical Features

Bolt suited for mounting on doors for frequent use (use category 4 - very heavy duty use - In compliance with EN12051: 1999).

Reversible it is applied on the profile, both at the top and at the bottom of the door.

Bolt tip with features of high break-in security.

Bolt tip stroke 21 mm.

Section of the bolt tip 8x5 mm.

Fixing to the profile with self-tapping screws.

Modular protective cover in aluminium.

Available in lengths of 140, 220, 450 and 650 mm to choose from depending on the best position for the thrust lever, depending on the height of the door.

Possible also in various other lengths, depending on the particular application needs.

Materials

- Body made of painted zamak
- Zamak operating lever with polished chrome (high corrosion resistance)
- Extruded aluminium modular cover
- Spring, connecting brackets, pins and fixing screws made of stainless steel
- Stainless steel bolt tip (high corrosion resistance)

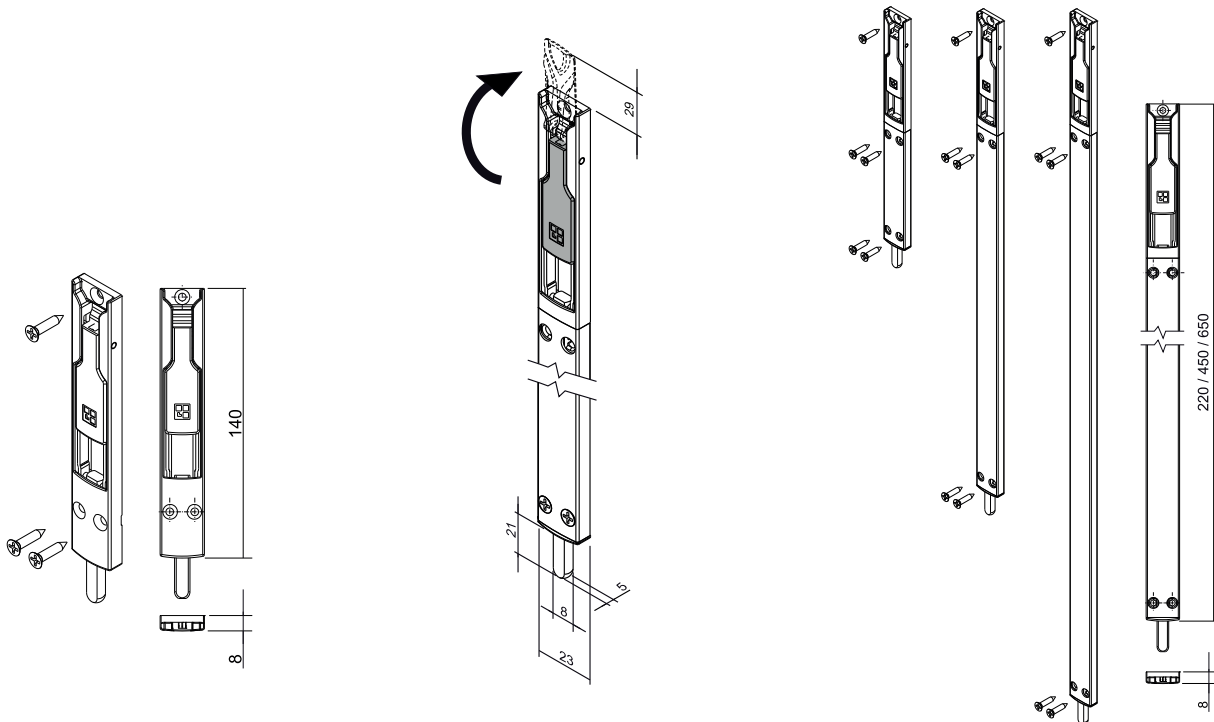

Item code	Description	Length	Dimensions bolt tip	Base Raw	Anodised Elox	Painted	Trend/Gold Brass	Pieces per pack
02080	MAYA BOLT	140 mm	8x5 mm			X		10
02081	MAYA BOLT	220 mm	8x5 mm			X		10
02082	MAYA BOLT	450 mm	8x5 mm			X		10
02083	MAYA BOLT	650 mm	8x5 mm			X		10

DOOR TOTEM BOLTS

Online data sheet



Functions

One-way lever bolt for door profile.

Technical Features

Bolt suited for mounting on doors for frequent use.
 Reversible it is applied on the profile, both at the top and at the bottom of the door.
 Bolt tip with features of high break-in security.
 Bolt tip stroke 20 mm.
 Section of the bolt tip 8x7 mm.
 Fixing to the profile with self-tapping screws.
 It is possible to extend the bolt by using the specific rod in the series, positioned between the connecting element and the terminal.

Materials

Slider and block in black painted zamak
 Body and bolt tip guide in polyamide
 Cut-proof 8x7 mm bolt tip in carbonitrided steel
 Operating lever in zamak with GS Silver Plus finish (up to 500 h corrosion resistance)
 Spring, connecting brackets and pins in stainless steel
 Polyamide connecting plate
 Black oxidized aluminium fixing plate (only for art. 02185)
 Blackened stainless steel fixing screws
 Blackened stainless steel mounting grub screw (only for art. 02185)

art. 02170

Application of extension
with art. 02170

art. 02185

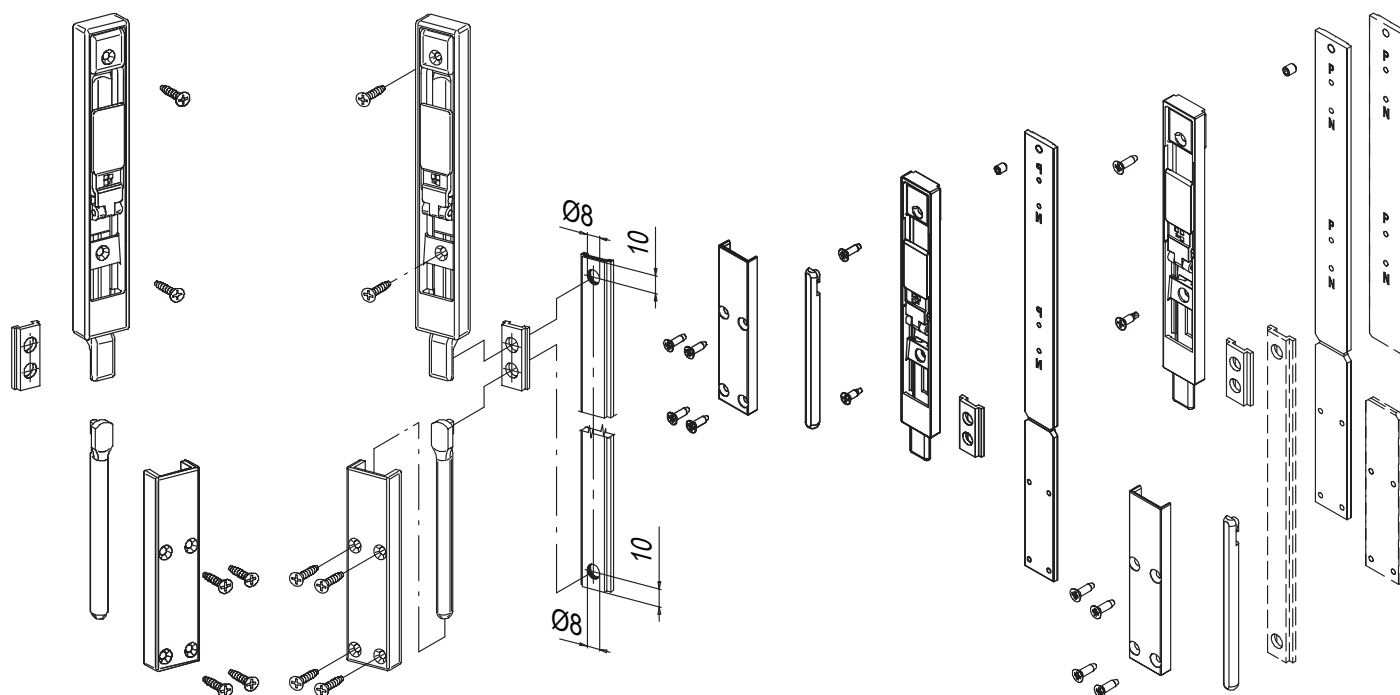
Application of extension
with art. 02185

DOOR BOLTS

Assembly art. 02185

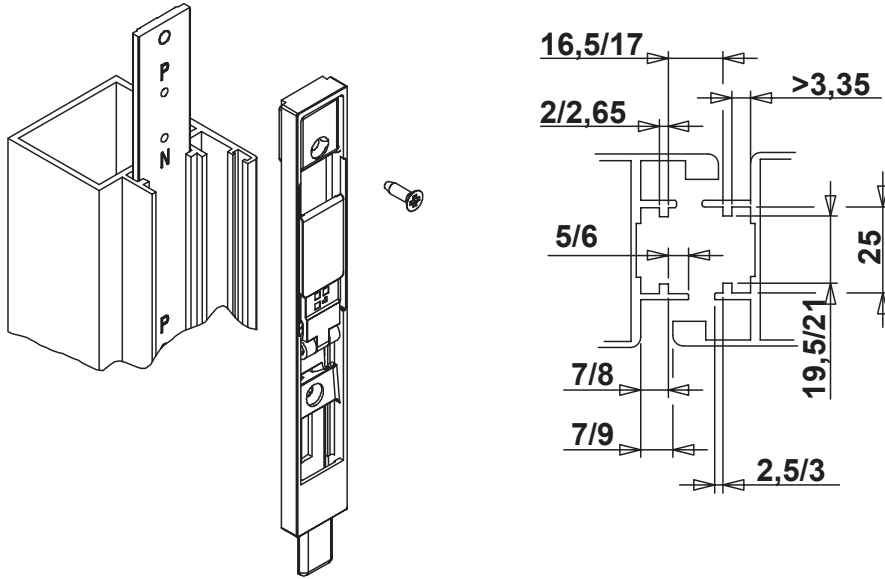

Item code	Description	Dimensions bolt tip	Base Raw	Anodised Elox	Painted	Trend/Gold Brass	Pieces per pack
02170	TOTEM DOOR BOLT	8x7 mm	X				10
02185	TOTEM DOOR BOLT	8x7 mm	X				10



PESOS BOLTS

Functions

One-way recessed lever bolt for doors.
To be combined with the aluminium front cover.

Online data sheet



Technical Features

Bolt suited for mounting on doors for frequent use.
Reversible it is applied on the profile, both at the top and at the bottom of the door.

The lever operation allows you to gradually exert a great force on the bolt tip.
Bolt tip stroke 18 mm.

It is recessed, by machining the profile.

Prepared for a double drilling diameter, it uses operating rods of $\varnothing 6$ mm or $\varnothing 8$ mm.

Can be combined with the casing that can be painted in standard RAL colours to be fitted onto the body of the bolt.

The bolt can be combined:

- to the safety terminal $\varnothing 8$ mm with cut-proof characteristics, in order to ensure a great hold on the strikers and high burglar resistance. It is joined to the bolt with an M6 threaded die cut to size by the user
- to the reversible rod guide, with double holes for rods $\varnothing 6$ and $\varnothing 8$ to be applied on the uprights in the case of kickplates, to keep the terminal in line inside the tubular profile.

Materials

Bolt and front cover

- Body and lever made of die-cast zamak
- Tempered steel springs
- Extruded aluminium cover
- Stainless steel fixing screws

Security terminal

- Pin $\varnothing 8$ made of cut-proof carbonitrided steel

Rod guide

- Zinc plated steel



art. 02151

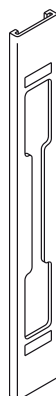

A = art. 02150

B = art. 02151

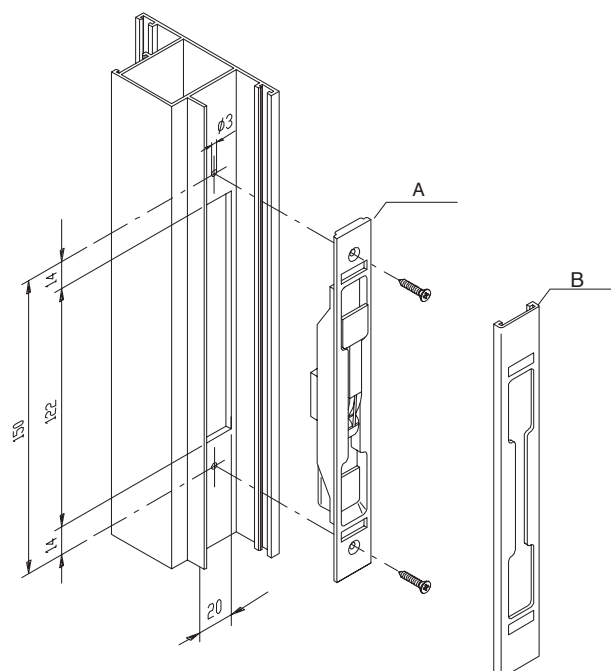

art. 02340

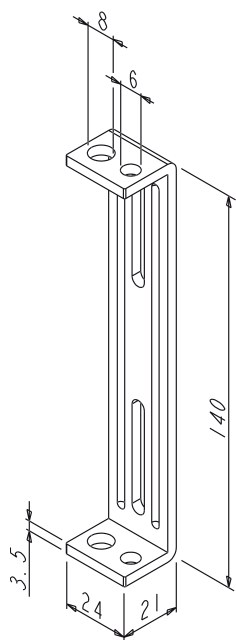

A = M6 threaded die
 B = terminal art. 02158
 C = rod guide art. 02340

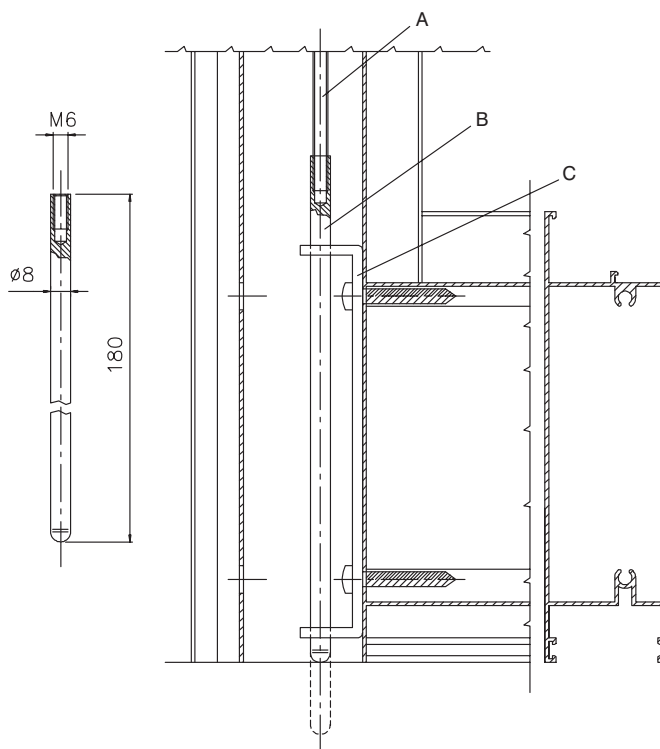

Item code	Description	Dimensions bolt tip	Base Raw	Anodised Elox	Painted	Trend/Gold Brass	Pieces per pack
02150	PESOS BOLT	Ø6/Ø8 mm	X				10
02151	PESOS FRONT COVER		X	X	X	X	50
02158	SECURITY TERMINAL FOR PESOS	Ø8 mm	X				50
02340	GUIDE FOR ROD		X				50



BULL BOLTS

Functions

Front application one-way bolt for doors.

Online data sheet



Technical Features

Bolt suited for mounting on doors for frequent use. Normally used as an extra security fastening mechanism on doors of any type. Reversible it is applied on the profile, both at the top and at the bottom of the door.

Bolt tip in stainless steel (corrosion-proof) of \varnothing 10 mm.

Bolt tip stroke 40 mm.

Notch positioning for immediate perception of the opening and closing position (Giesse patented system).

Fixing to the profile with self-tapping screws. The bolt body may be used as a template for drilling fixing holes.

The casing to be snap-fixed on the body of the bolt hides the fixing screws.

Available in version with key and without key.

Can be combined with the front mounting striker plate, for fastening on the top cross beam of the door or of a counter-frame.

The striker is equipped with no.4 shims for application to profiles with a step.

Materials

Bolt

- Body made of die-cast zamak with GS 500 finish
- Stainless steel bolt tip (high corrosion resistance)
- Black polyamide handle
- Fixing screw cap casing made of extruded aluminium
- Stainless steel fixing screws

Striker plate

- Striker plate made of die-cast zamak with GS 500 finish
- Polyamide shims (black)
- Blackened stainless steel fixing screws

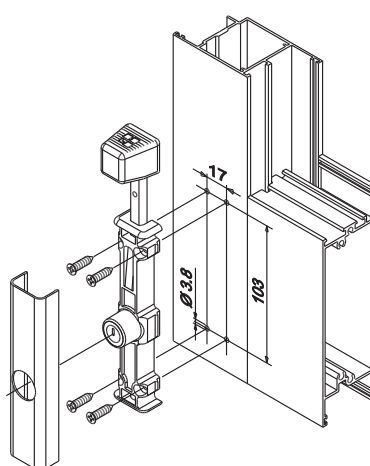
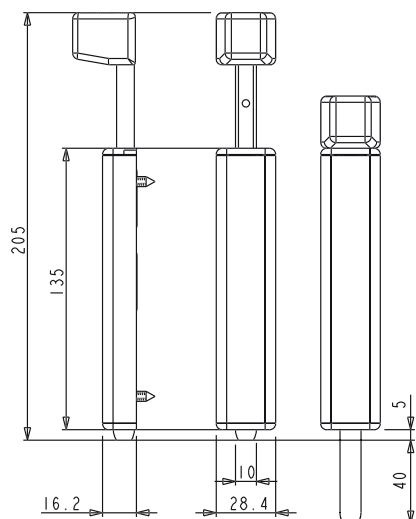

Bull bolt striker assembly

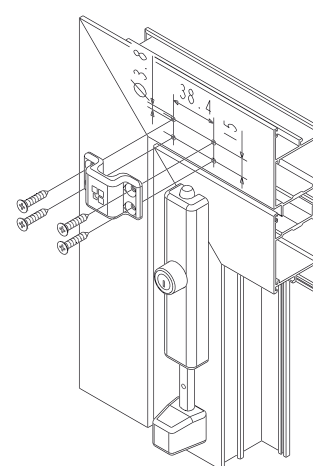

Item code	Description	Version	Dimensions bolt tip	Base Raw	Anodised Elox	Painted	Trend/Gold Brass	Pieces per pack
02180	BULL BOLT	without key	\varnothing 10 mm	X	X	X	X	5
02181	BULL BOLT	with key	\varnothing 10 mm	X	X	X	X	5
02182	BULL BOLT STRIKER PLATE			X				20



STELVIO BOLT

Functions

One-way recessed lever bolt for doors.

Online data sheet



Technical Features

Bolt suited for mounting on doors for frequent use.

Reversible it is applied on the profile, both at the top and at the bottom of the door.

The lever operation allows you to gradually exert a great force on the bolt tip.

Bolt tip stroke 16 mm.

It is recessed, by machining the profile.

Compatible with threaded rods of \varnothing 6 mm.

Two versions are available, with different C/C distance for fixing to the profile.

Materials

- Extruded aluminium body
- Internal fastening mechanisms and levers made of polyamide
- Tempered steel springs
- Connecting brackets and fixing screws made of zinc plated steel

Article 02101

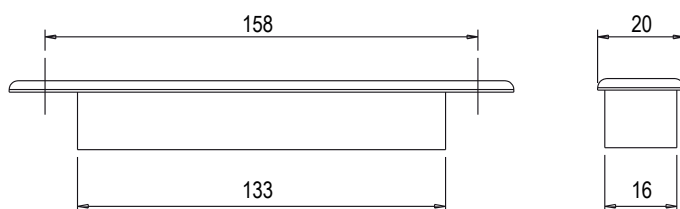

Article 02102

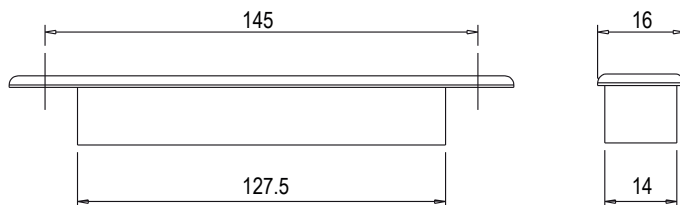

Item code	Description	C/C distance	Width	Base Raw	Anodised Elox	Painted	Trend/Gold Brass	Pieces per pack
02101	STELVIO BOLT	158 mm	20 mm	X	X	X		50
02102	STELVIO BOLT	145 mm	16 mm	X	X	X		50

FLOOR STRIKER PLATES

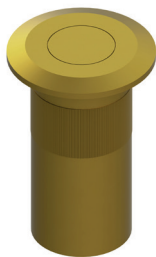

Functions

Strikers and bushings to combine with rods and bolts, if the threshold is used as counter-frame.

Online data sheet



01320

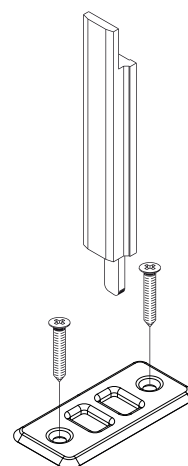
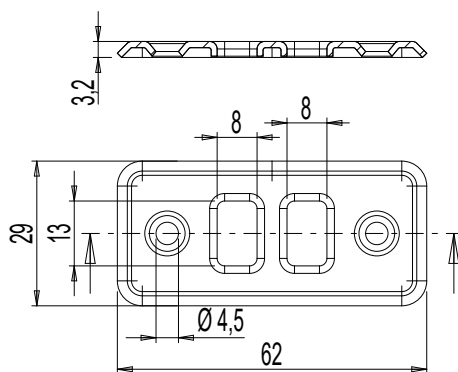
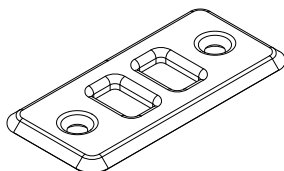

01326

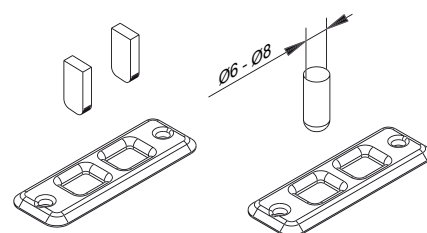
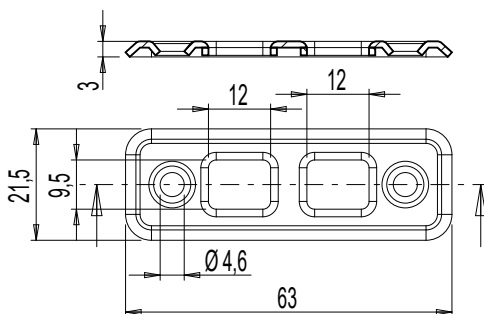
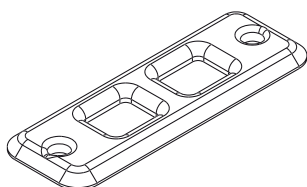

02144

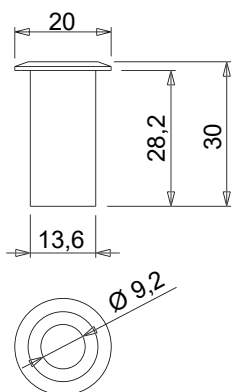
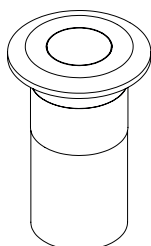

DOOR BOLTS

02159

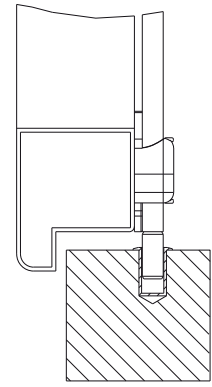
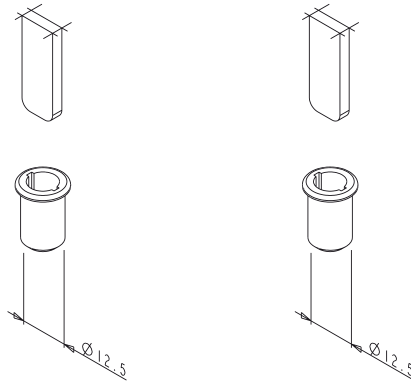
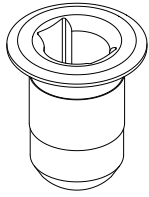

02183

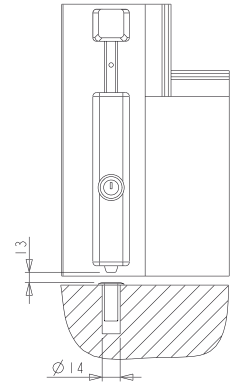
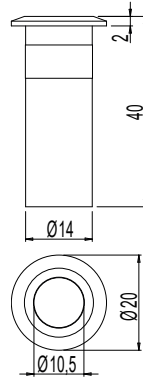
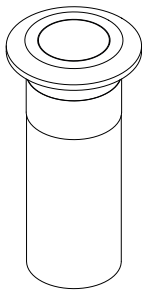

03901

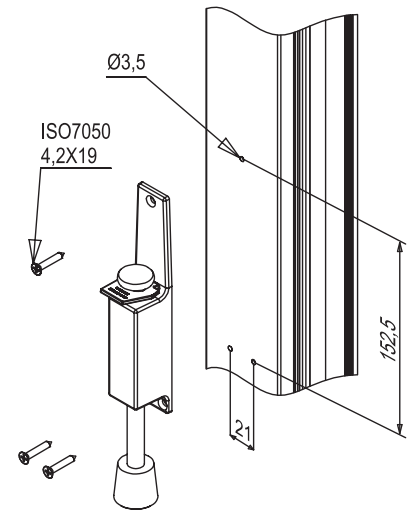
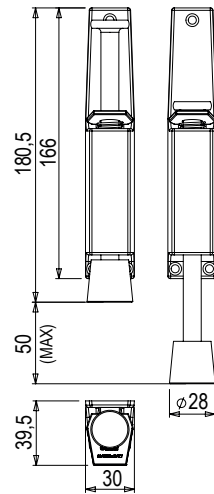
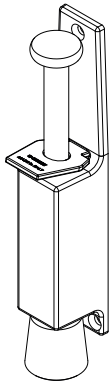

Item code	Description	Note	Base Raw	Anodised Elox	Painted	Trend/Gold Brass	Pieces per pack
01320	ROD STRIKER PLATE for sill	stainless steel	X				100
01326	ROD STRIKER PLATE FOR SILL		X				100
02144	THRESHOLD BUSH WITH SHUTTER		X				100
02159	THRESHOLD BUSH		X				50
02183	BULL BOLT THRESHOLD BUSH		X				20
03901	DOOR STOP		X				20

FUTURA ADJUSTABLE TERMINALS



Functions

Terminal equipped with adjustable offset terminal, to recover the play that can form during operation of the window.

Online data sheet



Technical features

Adjustable terminal for use on main sash and/or on secondary sash (additional profiles) with channels of dimensions 15 to 20 mm.

Adjustable terminal for use on main sash and/or on secondary sash.

Materials

Body and terminal in GS Silver Plus zamak (over 500 hours of corrosion resistance)

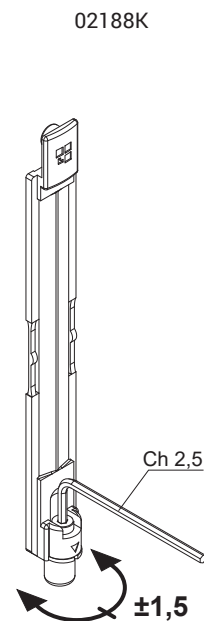
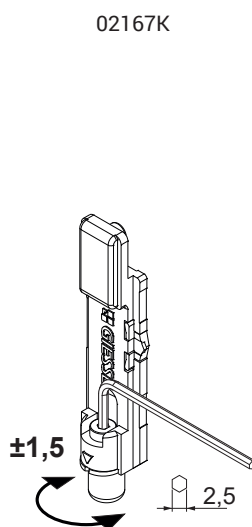
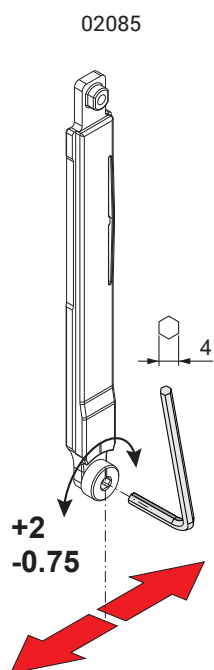

Item code	Description	PROFILE CROSS - SECTION	Adjustment (mm)	Base Raw	Anodised Elox	Painted	Trend/Gold Brass	Pieces per pack
02085	ERRE 40 ADJUSTABLE TERMINAL	C007	+2 / -0,75	X				40
02167K	FUTURA ADJUSTABLE TERMINAL	C001-C002-C003-C005-C006-C009-C010-C012-C013-C014-C015-C016-C017	±1.5	X				40
02188K	FUTURA ADJUSTABLE TERMINAL	C001-C002-C003-C005-C006-C009-C010-C012-C013-C014-C015-C016-C017	±1.5	X				40

TOTEM TERMINALS



Functions

Polyamide terminal with steel bolt tip for fixing sashes to the frame cross beams.

[Online data sheet](#)



Technical Features

Bolt tip suited for mounting on doors for frequent use, with cut-proof characteristics, in order to ensure a great hold on the strikers and high break-in security.

Reversible it is applied both at the top and at the bottom of the door.

Stroke is 21 mm.

Compression adjustment +0.6 mm on the strikers with the eccentric bush provided with all versions, except for the one for groove 15x18.

Fixing to the mechanism using the connecting block supplied with the mechanism or with the specific rod in the series, cut to the desired size for the bolt extension.

Materials

Terminal and eccentric bush covering bolt tip in polyamide

Bolt tip made of cut-proof carbonitrided steel with Giesse Silver Plus finish (up to 500 h corrosion resistance)

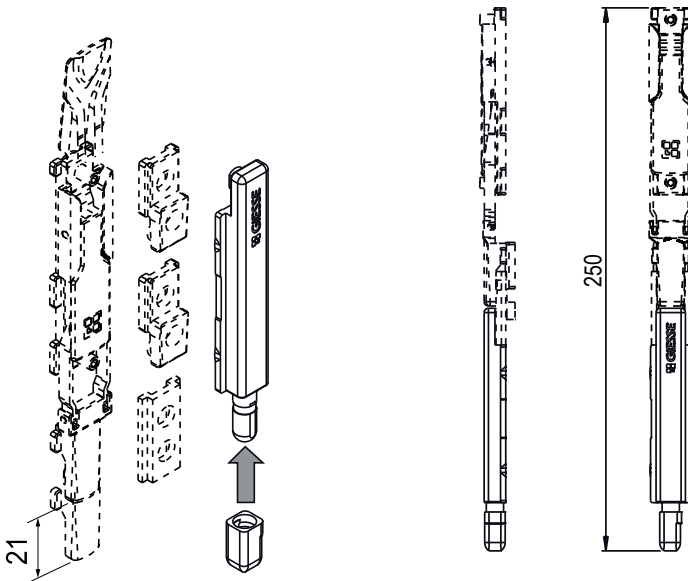

Sect. 2 - Groove 14x19

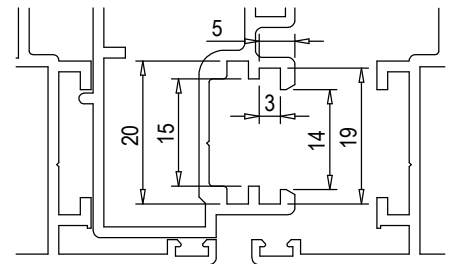

Sect. 3 - Groove 15x20

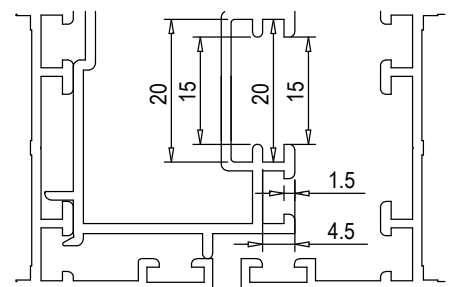

Item code	Description	Groove	Adjustment	Offset terminal	Dimensions bolt tip	Drawing	Base Raw	Anodised Elox	Painted	Trend/Gold Brass	Pieces per pack
02143N	TOTEM TERMINAL	15x20	+ 0.6 mm		Ø 8 mm	sect.3	X				50
02145N	TOTEM TERMINAL	14x19	+ 0.6 mm		Ø 8 mm	sect.2	X				50

TERMINALS



Functions

Polyamide terminal for rods with steel pin for fixing sashes to the frame cross beams.

Online data sheet



Technical Features

For the direct fixing where mounting is required in conjunction with the strikers, you will have to engage the supplied polyamide adjustable bush on the pin to achieve a perfect coupling.

To mount on GIESSE locking rods, in the same way the rod is mounted to the connecting block.

Materials

Body and bush in polyamide with fibreglass.
Terminal pin of zinc-nickel plated steel.

Type 1

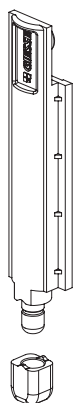

Type 2



Type 3

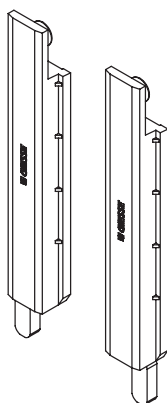

Type 4



Type 5



Item code	Description	Type	Groove (mm)	Offset terminal	Adjustment (mm)	Colour	Base Raw	Anodised Elox	Painted	Trend/Gold Brass	Pieces per pack
02114	TERMINAL FOR RODS	1	15 ÷ 20	-	+ 0,8	Black	X				50
02114K	TERMINAL FOR RODS	1	15 ÷ 20	-	+ 0,8	Grey	X				50
02140	TERMINAL FOR RODS	2	23,6 ÷ 31	-	+ 0,8	Black	X				50
02141	TERMINAL FOR RODS	3	15 ÷ 18	-	-	Black	X				25
02141K	TERMINAL FOR RODS	3	15 ÷ 18	-	-	Grey	X				25
02142	TERMINAL FOR RODS	3	20 ÷ 23	-	-	Black	X				25
02146	TERMINAL FOR RODS	4	20 ÷ 23	-	-	Black	X				50
02161	TERMINAL FOR RODS	5	15 ÷ 20	YES	-	Black	X				25
02162	TERMINAL FOR RODS	5	15 ÷ 20	YES	-	Black	X				50
02163	TERMINAL FOR RODS	5	15 ÷ 20	YES	-	Black	X				50

CORNER DRIVES



Functions

Component for moving the hardware from the cremone side to the upper and/or lower cross-beam.

Online data sheet



Technical Features

Reversible, right/left, it is mounted with no need to machine the profile. Snap-fitting, it is removed with a screwdriver. Some models are equipped with a fixed pawl with which, in combination with an adjustable striker, to make a locking point on the cremone side or on the cross-beam.

Materials

Body, connection device and clip made of zamak with GS Silver Plus finish (over 500 h of corrosion resistance)

Grub screws and plates in stainless steel

Art. 04017K

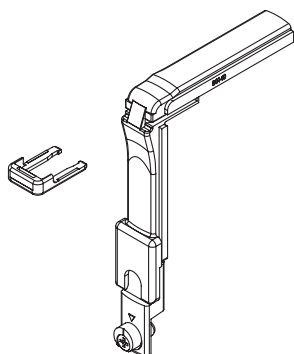

Art. 04019K

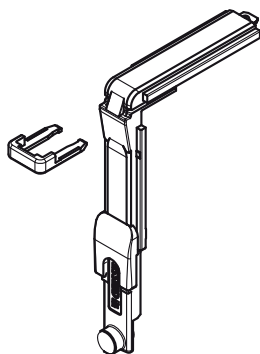

Art. 04020K

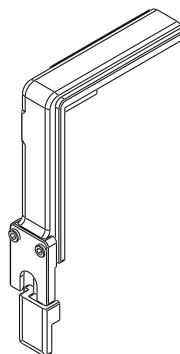

Art. 04023K

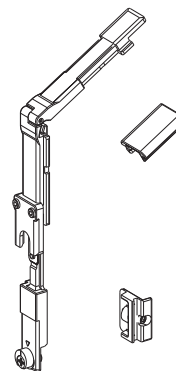

Item code	Description	PROFILE CROSS - SECTION	Range (mm)	Version	Base Raw	Anodised Elox	Painted	Trend/Gold Brass	Pieces per pack
04017K	FUTURA CORNER DRIVE	C007	-	-	X				10
04019K	CORNER DRIVE GROOVE 15/20 FUTURA	C001-C002-C003-C004-C005-C006-C009-C010-C011-C012-C013-C014-C015-C016-C017	-	-	X				10
04020K	FUTURA CORNER DRIVE	C001-C002-C003-C004-C005-C006-C009-C010-C011-C012-C013-C014-C015-C016-C017-P001-P002-P003-P004-P005-P006-P007-P008-P009-P010	-	-	X				50
04023K	VARIABLE CORNER DRIVE	C001-C002	-	-	X				10

CONNECTION RODS



Functions

Connection rod for the operating mechanism.

Online data sheet



Technical Features

Specially made to be machined, as in the figure, by the semiautomatic machines PM008 and PA009 and by the automatic machines GS003, GS008, GS009 and TF10.

Roll packing makes for considerable reductions in overall dimensions, since a roll of diameter 90 cm contains the equivalent of over 40 bars of 6 m of aluminium.

The rod extension element enables fitting the incorrect movement safety striker and the fastening striker on the central upright on casements with two sashes where the bolt is located.

Materials

Fibreglass-reinforced polyamide

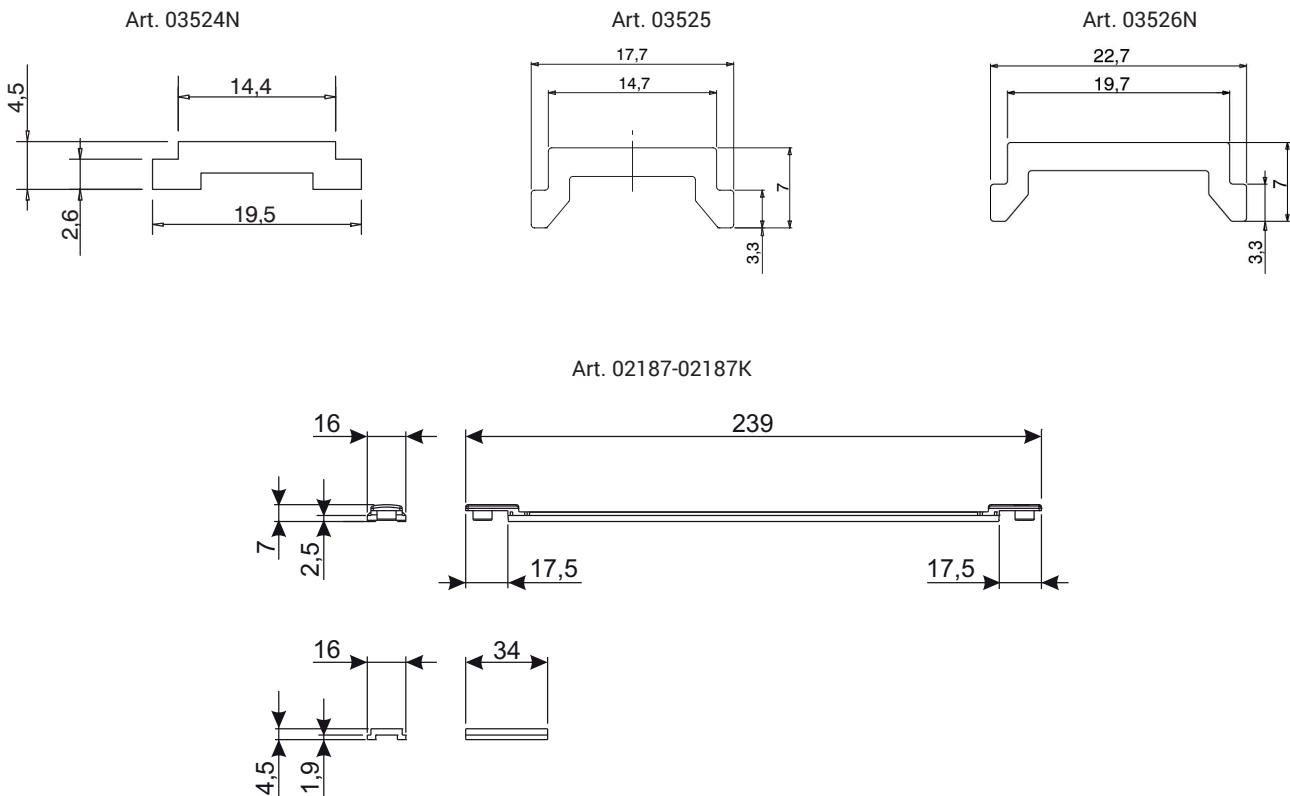

Item code	Description	PROFILE CROSS - SECTION	Groove (mm)	Colour	Base Raw	Anodised Elox	Painted	Trend/Gold Brass	Pieces per pack
01216	ROD EXTENSION COMPONENT	C007	15 ÷ 18	Grey	X				20
02187	ROD EXTENSION COMPONENT	C001-C002-C003-C004-C005-C006-C009-C010-C012-C013-C014-C015-C016-C017	15 ÷ 20	Black	X				20
02187K	ROD EXTENSION COMPONENT	C001-C002-C003-C005-C010-C011-C012-C013-C014-C015-C016-C017	15 ÷ 20	Grey	X				20
03524N	CONNECTION ROD	C001-C013-C016-C017-P002	15 ÷ 20	-	X				1
03525	CONNECTION ROD	C007	15 ÷ 18	-	X				1
03526N	CONNECTION ROD	C008	20 ÷ 23	-	X				1

PAWLS

Functions

Pawl to be combined with a striker, required to create a locking point.

Online data sheet



01319K

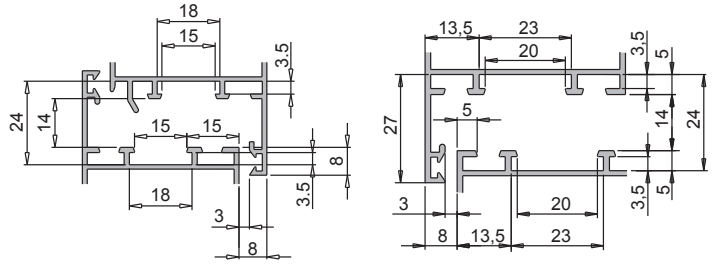
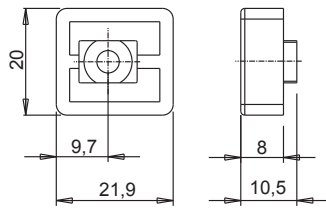
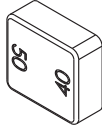
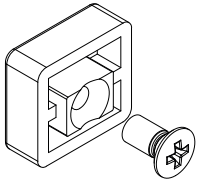

A = pin B= striker

01332

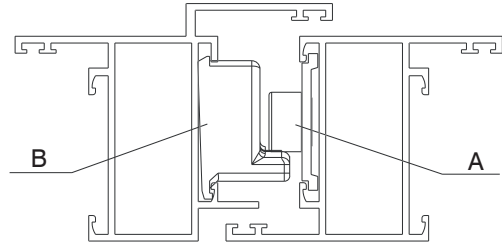
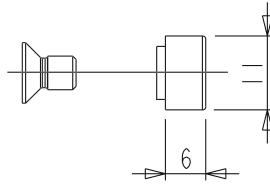
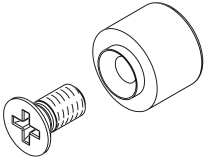

01333

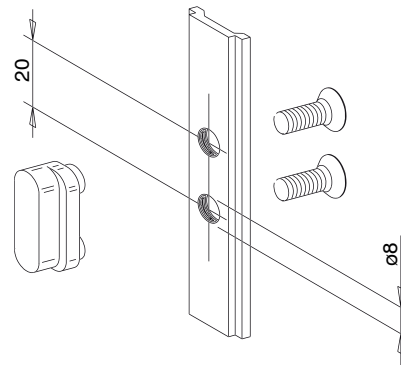
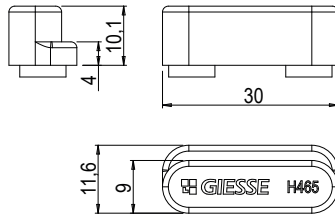
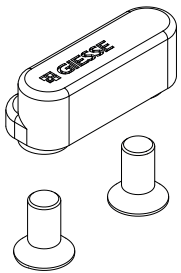

01352K

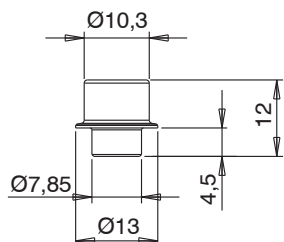
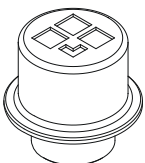

01356K

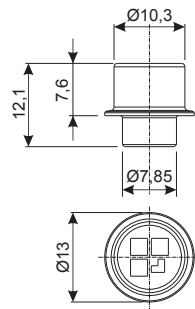
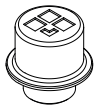

02315K

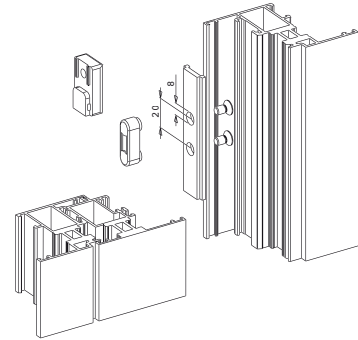
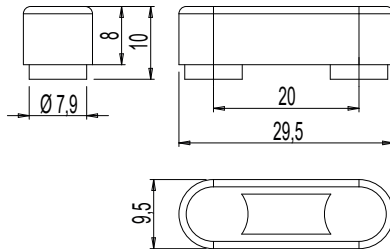
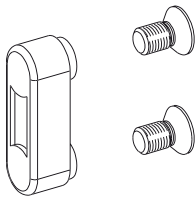

02320

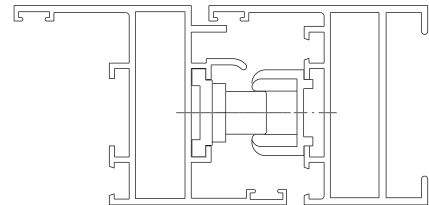
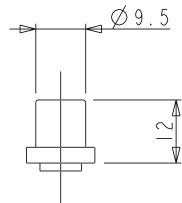
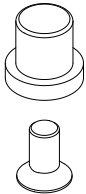

04027K

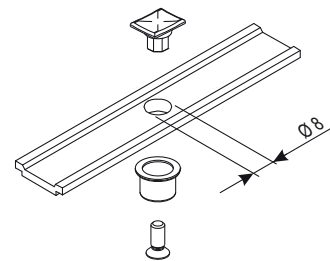
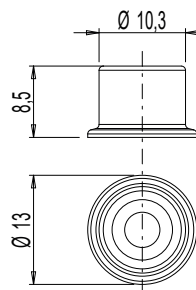

04030K

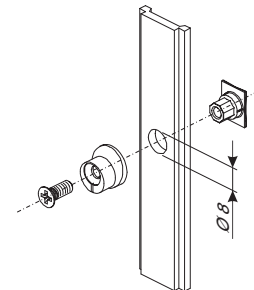
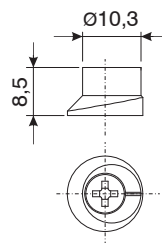

04042K

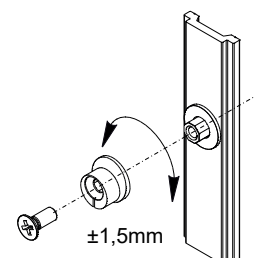
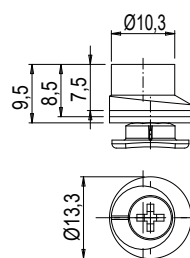
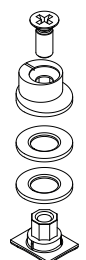

STRIKERS AND FASTENING MECHANISMS

04049

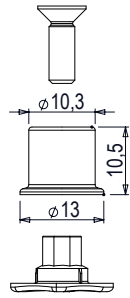

04050

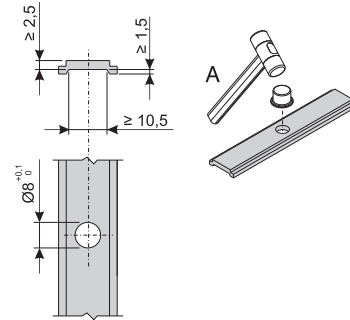
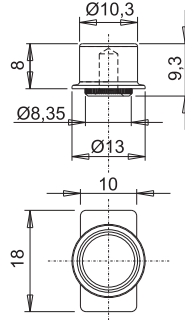
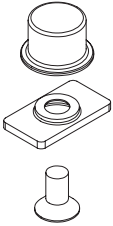

04067

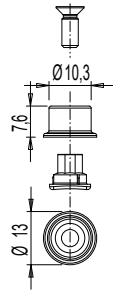
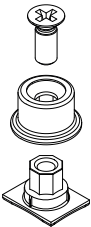

Item code	Description	PROFILE CROSS - SECTION	Base Raw	Anodised Elox	Painted	Trend/Gold Brass	Pieces per pack
01319K	3RD FASTENING MECHANISM STRIKER	C007	X				200
01332	PIN FOR ADDITIONAL FASTENING MECHANISMS		X				50
01333	ADDITIONAL FASTENING MECHANISM COMPONENT	C001-C002-C004-C010-C011-C013-C014-C015-C016-C017	X				50
01352K	LOCKING PAWL (8 TUBES OF 50 PIECES)	C001-C002-C003-C004-C005-C006-C007-C008-C009-C010-C011-C012-C013-C014-C015-C016-C017-P001-P002-P003-P004-P005-P006-P007-P008-P009-P010	X				400
01356K	ADDITIONAL PAWL (BULK)	C001-C002-C003-C004-C005-C006-C007-C008-C009-C010-C011-C012-C013-C014-C015-C016-C017-P001-P002-P003-P004-P005-P006-P007-P008-P009-P010	X				400
02315K	ADDITIONAL FASTENING MECHANISM COMPONENT	C001-C002-C005-C010-C013-C014-C015-P001-P005-P006	X				500
02320	PIN FOR ADDITIONAL FASTENING MECHANISMS	C010	X				500
04027K	FUTURA FIXED PAWL	C001-C002-C003-C005-C006-C013-C014-C015-C016-C017-P001-P002-P003-P004-P005-P006-P008-P009-P010	X				200
04030K	ADJUSTABLE LOCKING PAWL	C001-C002-C003-C005-C007-C008-C011-C013-C014-C015-C016-C017-P001-P002-P004-P005-P006-P007-P008-P009-P010	X				200
04042K	ADJUSTABLE LOCKING PAWL	C001-C002-C003-C004-C005-C006-C007-C008-C009-C010-C011-C012-C013-C014-C015-C016-C017-P001-P002-P003-P004-P005-P006-P007-P008-P009-P010	X				200
04049	FIXED PAWL		X				200
04050	FIXED PAWL	C001-C002-C003-C004-C005-C006-C007-C008-C009-C010-C011-C012-C013-C014-C015-C016-C017-P001-P002-P003-P004-P005-P006-P007-P008-P009-P010	X				200
04067	FUTURA FIXED PAWL		X				200

PAWLS 009

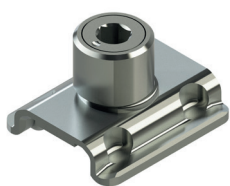

Functions

Closing element for insertion, in combination with a suitably shaped rod, in the 15/20 mm sash channel.

Online data sheet



Technical Features

The pawl is applied directly on the manual quick-fitting rod. In order to install it you need to machine the connection rod.
For the adjustments and correct application on the profiles please refer to the table.

Materials

Stainless steel

Fastener pawl base

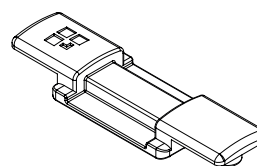

Fastener pawl

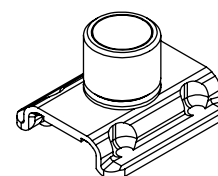

Rod machining

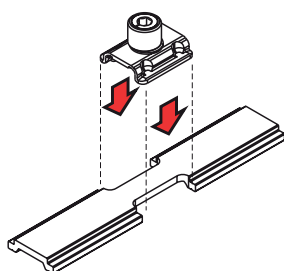
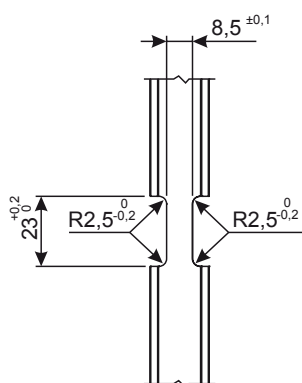

Adjustment

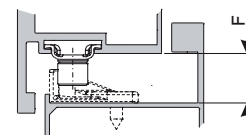
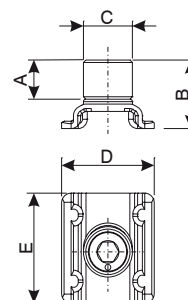
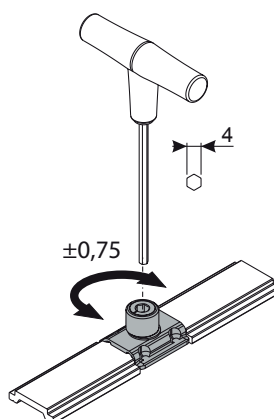

Item code	Description	PROFILE CROSS - SECTION	A (mm)	B (mm)	C (mm)	D (mm)	E (mm)	F (mm)	Adjustment (mm)	Base Raw	Anodised Elox	Painted	Trend/Gold Brass	Pieces per pack
01373	LOCKING PAWL	-	6,5	11,5	-	19,5	22,5	11,5	No	X				20
01394	LOCKING PAWL	-	8	14	10,3	19,5	22,5	16.5/17	+/- 0.75	X				100
01395	LOCKING PAWL	C001-C002-C003-C004-C005-C006-C011-C012-C013-C014-C015-C016-C017-P001-P002-P003-P004-P005-P006-P007-P008-P009-P010	5,5	11,5	10,3	19,5	22,5	11,5	+/- 0.75	X				100
01399	CLOSING PAWL BASE	C001-C002-C003-C004-C005-C006-C011-C012-C013-C014-C015-C016-C017-P001-P002-P003-P004-P005-P006-P007-P008-P009-P010	-	-	-	-	-	-	-	X				100
04052	LOCKING PAWL	C001-C002-C003-C004-C005-C006-C011-C012-C013-C014-C015-C016-C017-P001-P002-P003-P004-P005-P006-P007-P008-P009-P010	5,5	11,5	10,3	19,5	22,5	11,5	No	X				100
04054	LOCKING PAWL	-	8	14	10,3	19,5	22,5	16.5/17	No	X				100

PAWLS FOR CURTAIN WALL



Functions

Adjustable pawl to be applied on the "Giese connection element" which, in combination with a fixed striker, creates a locking point for a window.

Online data sheet



Technical Features

The pawl is applied "on the Giese connection element" by means of a screw supplied with the pawl.
The pawl with the most suitable height will be appraised according to the sash - frame distance of the series.
The adjustable pawl is used in combination with a fixed striker placed on the frame.
For the adjustments please refer to the table.

Materials

Pawl in zamak with GS Silver Plus finish (over 500 hours of corrosion resistance)
Stainless steel screw

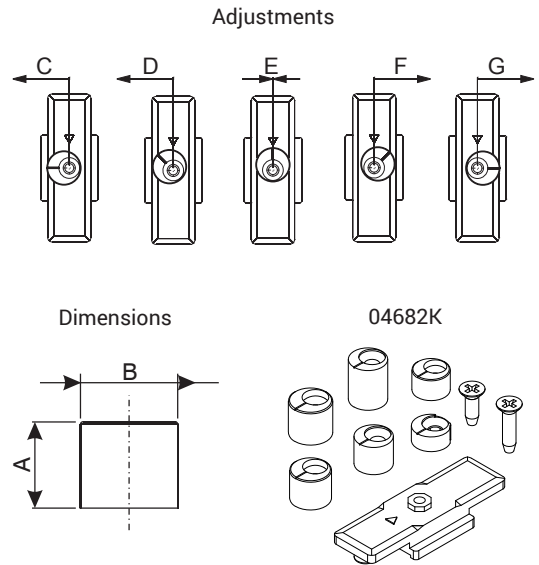
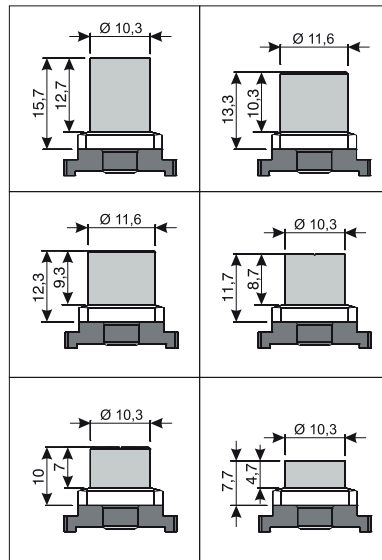
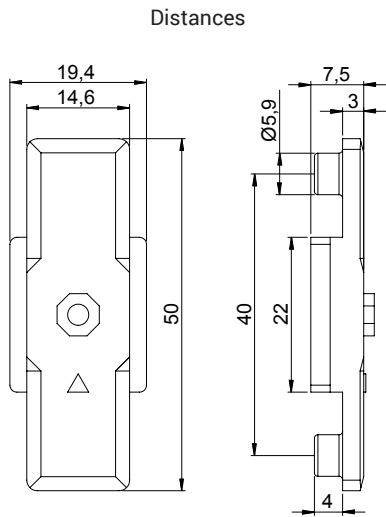

Item code	Description	PROFILE CROSS - SECTION	Dimensions A (mm)	Dimensions B (mm)	Adjustment C (mm)	Adjustment D (mm)	Adjustment E (mm)	Adjustment F (mm)	Adjustment G (mm)	Base Raw	Anodised Elox	Painted	Trend/Gold Brass	Pieces per pack
02215K	CONNECTION JOINT	C001-C002-C003-C004-C005-C006-C009-C010-C011-C012-C013-C014-C015-C016-C017-P001-P002-P003-P004-P005-P006-P007-P008-P009-P010								X				100
04675K	LOCKING PAWL	-	12,7	10,3	+ 1,5	+ 1,06	0	- 1,06	- 1,5	X				100
04677K	LOCKING PAWL	-	10,3	11,6	+ 1,8	+ 1,27	0	- 1,27	- 1,8	X				100
04679K	LOCKING PAWL	-	8,7	10,3	+ 1,5	+ 1,06	0	- 1,06	- 1,5	X				100

CONNECTION JOINTS WITH PAWLS



Functions

Fixed connection joint, to be combined with the adjustable striker, required to create a lock point.

Online data sheet



Technical Features

The connection joint can be used at the end of a connection rod or to join two together. In both cases, matched with an adjustable striker, it makes a locking point.

It is highly resistant with high tear strength.

Materials

Connection element in zamak with Giesse Silver-Plus finish (over 500 h of corrosion resistance)

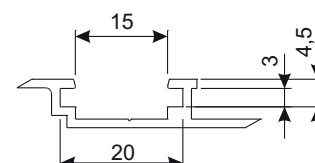
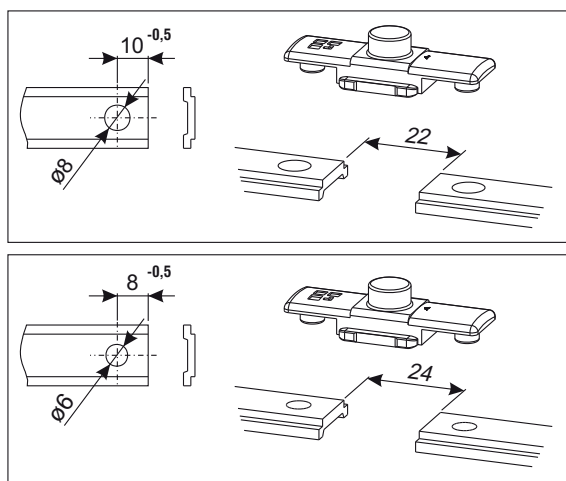
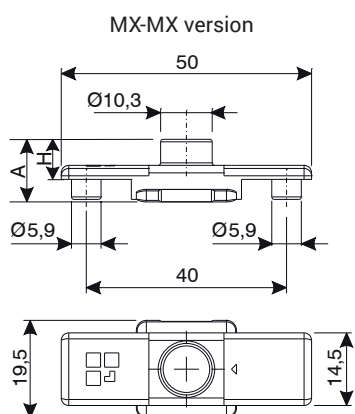

Item code	Description	PROFILE CROSS - SECTION	A	H	Base Raw	Anodised Elox	Painted	Trend/Gold Brass	Pieces per pack
04047K	FIXED CONNECTION JOINT MX-MX	C001-C002-C003-C004-C005-C006-C011-C012-C013-C014-C015-C016-C017-P001-P002-P003-P004-P005-P006-P007-P008-P009-P010	12.5 mm	8 mm	X				200

ADDITIONAL FASTENING MECHANISM COMPONENTS



Functions

Closing components specially designed to make an additional fastening mechanism, on side-hung windows with 1 or more sashes.

Online data sheet



Technical Features

It makes additional fasteners, both in the sash-frame interface of windows with 1 sash and in the profile cross-section of windows with 2 sashes.

Materials

Striker body made of zamak with GS SILVER PLUS finish.
Pin and screw of zinc-nickel plated steel
Stainless steel grub screw

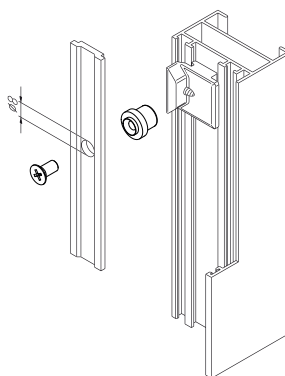
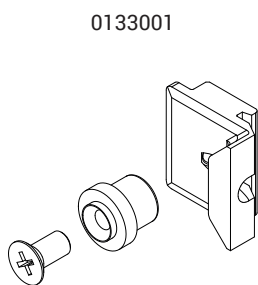
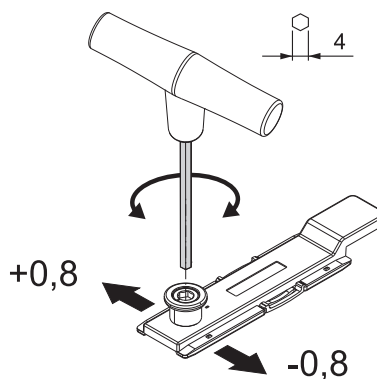
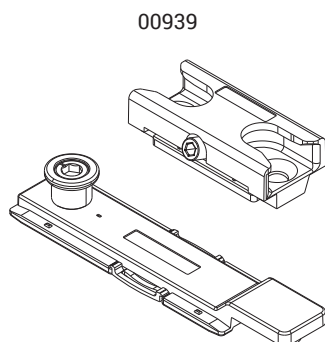

Item code	Description	Note	Base Raw	Anodised Elox	Painted	Trend/Gold Brass	Pieces per pack
00939	ADDITIONAL FASTENING MECHANISM KIT		X				200
0133001	STRIKER AND PIN FOR THIRD FASTENING MECHANISM		X				50

STRIKERS

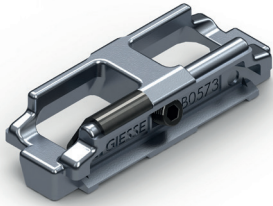

Functions

Components made to be fitted on frames of casements with one or more sashes with the function of accommodating the tips of bolts and terminals and the fastening pawls made by GIESSE.

Online data sheet



Type 1

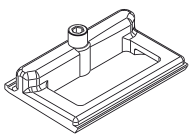

Type 2

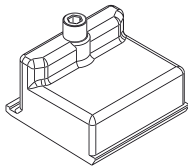

Type 3

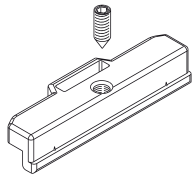

Type 4

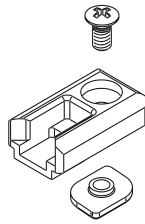

Type 5

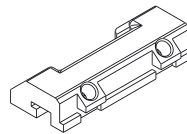

Type 6

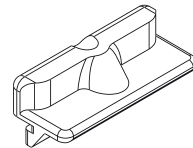

Type 7

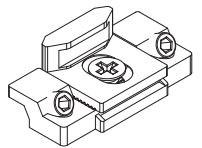

Type 8

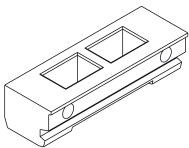

Type 9

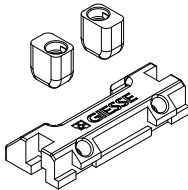

Type 10

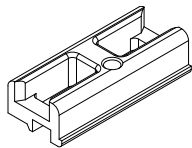

Type 11

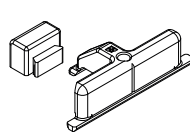

Type 12

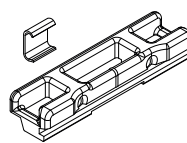

Type 13

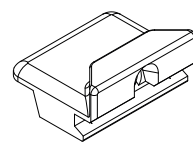

Type 14

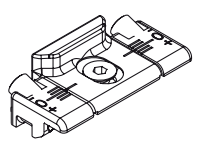

Type 15

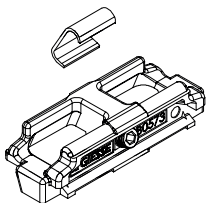

Type 16

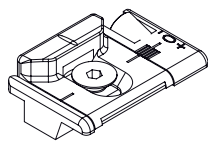

Type 18

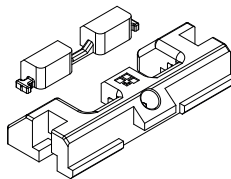

Compression adjustment

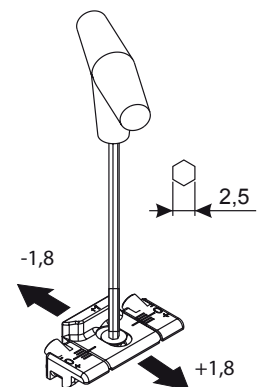

Type 19

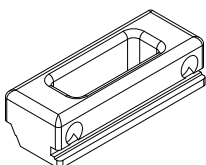

Type 20

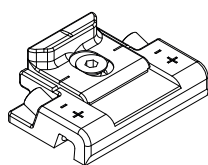

Type 22

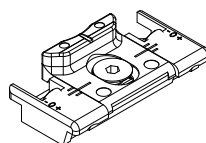

Side adjustment

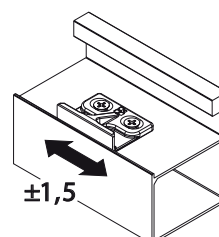

Adjustment art. 01348K

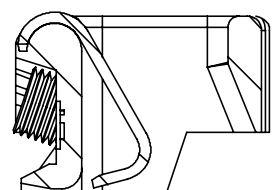

STRIKERS AND FASTENING MECHANISMS

Item code	Description	Type	Type	PROFILE CROSS - SECTION	Adjustable (mm)	Material	Colour	3° fastening mechanism	Base Raw	Anodised Elox	Painted	Trend/Gold Brass	Pieces per pack
01215	STRIKER	18	Double	C007	No	Zamak	Grey		X				100
0130501	STRIKER	1	Double	see Where Used	No	Zamak	Grey		X				100
0130601	STRIKER	2	Single	see Where Used	No	Zamak	Grey	X	X				100
0130701	STRIKER	3	Double	C009	No	Zamak	Grey	X	X				100
01314K	STRIKER	4	Single	C001-C002-C004-C011-C012-C013-C014-C015-C016-C017	No	Zamak	Grey	X	X				100
0131501	STRIKER	4	Single	C010	No	Zamak	Grey	X	X				100
0131601	STRIKER	4	Single	see Where Used	No	Zamak	Grey	X	X				100
01317K	STRIKER	5	Double	C007-C008	No	Polyamide	Grey		X				100
01318K	STRIKER	6	Single	C007-C008	No	Zamak	Grey	X	X				200
01322	STRIKER	4	Double	C001-C002-C004-C011-C012-C013-C014-C015-C016-C017	No	Polyamide	Black	X	X				100
01322K	STRIKER	4	Double	C001-C002-C004-C011-C012-C013-C014-C015-C016-C017	No	Polyamide	Grey	X	X				100
01328	STRIKER	8	Double	see Where Used	No	Polyamide	Black		X				100
01329	STRIKER	9	Double	C009	No	Polyamide	Black		X				50
01331	STRIKER	10	Double	C010	No	Polyamide	Black		X				100
0133801	STRIKER	11	Double	see Where Used	No	Zamak	Grey	X	X				50
01339	STRIKER	12	Double	C001-C002-C004-C006-C011-C012-C013-C014-C015-C016-C017	+ 0.8 (compression)	Polyamide	Black		X				100
01340K	STRIKER	10	Double	C005	No	Polyamide	Grey		X				100
01340N	STRIKER	10	Double	C005	No	Polyamide	Black		X				100
01342K	STRIKER	13	Single	C003-C005-C006	No	Zamak	Grey		X				200
01343K	STRIKER	13	Single	C001-C002-C004-C011-C012-C013-C014-C015-C016-C017	No	Zamak	Grey		X				200
01344K	STRIKER	13	Single	C007	No	Zamak	Grey		X				200
01345K	STRIKER	13	Single	C008	No	Zamak	Grey		X				200
01347K	STRIKER	14	Single	C001-C002-C003-C004-C005-C006-C011-C012-C013-C014-C015-C016-C017	+ 1.8 (compression)	Zamak	Grey		X				200
01348K	STRIKER	15	Single	C001-C002-C004-C006-C011-C012-C013-C014-C015-C016-C017	+ 0.8 (compression)	Zamak	Grey		X				100
01349K	STRIKER	12	Double	C001-C002-C003-C004-C006-C011-C010-C011-C013-C014-C015	+ 0.8 (compression)	Zamak	Grey		X				100
01353K	STRIKER	16	Single	C001-C002-C003-C004-C005-C006-C011-C012-C013-C014-C015-C016-C017	+ 2.4 (compression)	Zamak	Grey		X				200
01362K	STRIKER	14	Single	C001-C002-C003-C004-C005-C006-C011-C012-C013-C014-C015-C016-C017	+ 1.8 (compression)	Zamak	Grey		X				200
01396	STRIKER	14	Single	see Where Used	+ 1.8 (compression)	Zamak/Brass	Grey		X				200
01398	STRIKER	20	Single	see Where Used	+ 1.8 (compression)	Zamak	Grey		X				200
01400	STRIKER	22	Single	see Where Used	+ 1.8 (compression)	Zamak	Grey		X				200
02337	STRIKER	19	Double	C001-C002-C004-C011-C012-C013-C014-C015-C016-C017	No	Polyamide	Black		X				100

DOOR STRIKERS



Functions

Component produced for application to the top and bottom part of the frame of doors with one or more sashes, having the function of accommodating bolt tips and bolts.

Online data sheet



01308

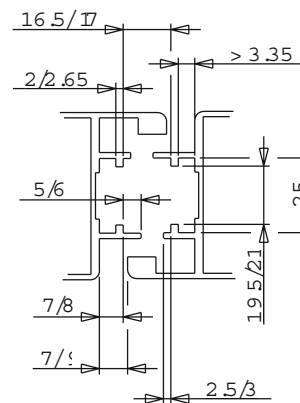
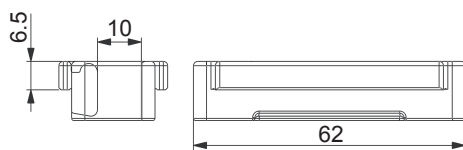
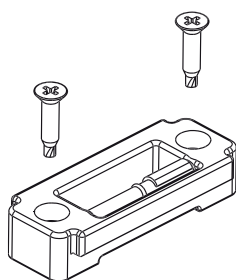

0132501

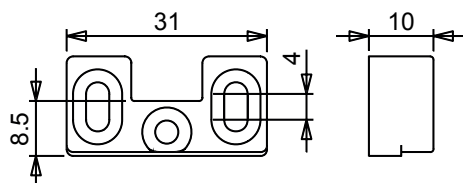
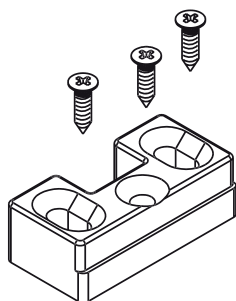

Item code	Description	Note	Base Raw	Anodised Elox	Painted	Trend/Gold Brass	Pieces per pack
01308	STRIKER FOR TOTEM FOR DOOR CHANNEL		X				50
0132501	PESOS-SUPERGIAP RODS STRIKER		X				100

STRIKERS FOR CURTAIN WALL FLAT FRAME



Functions

Fixed striker, to be combined with an adjustable pawl, necessary for making the locking points on a top-hung window or outward opening (side hung) window.

Online data sheet



01213

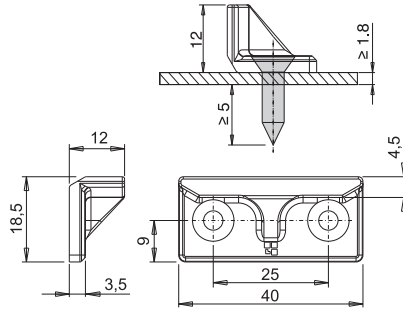
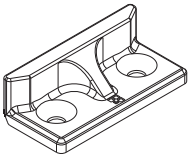

01214

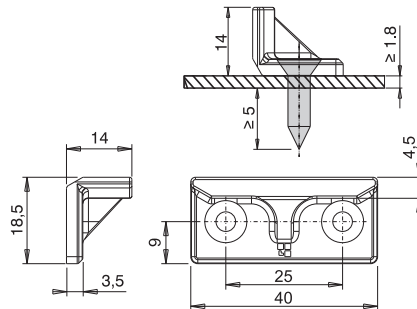
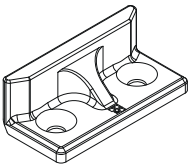

01266K

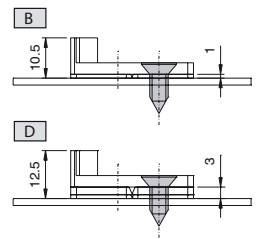
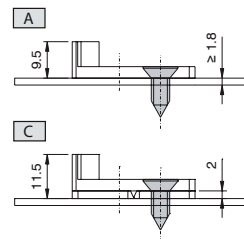
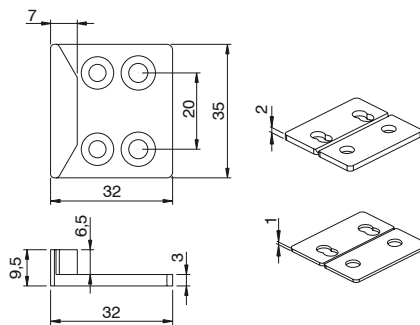
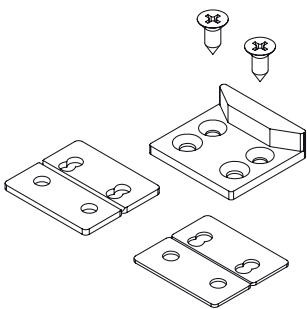

01267K

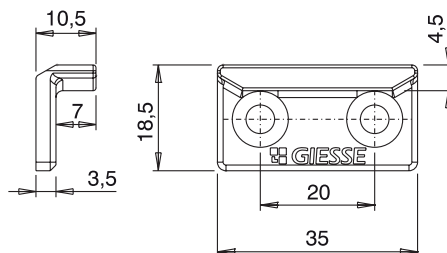
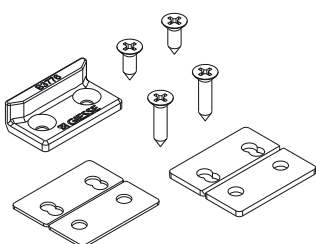

01268K

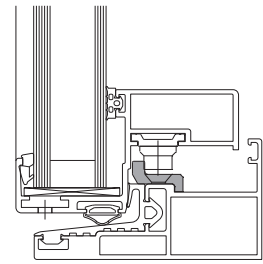
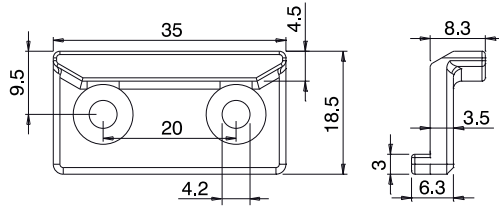
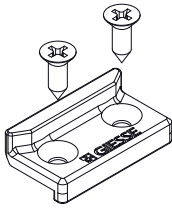

01269K

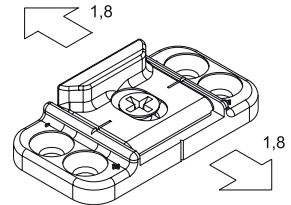
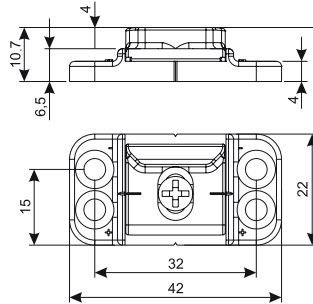
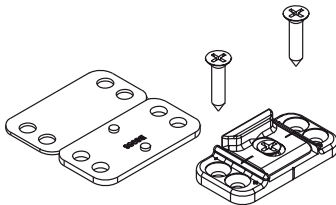

01280

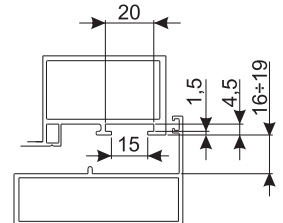
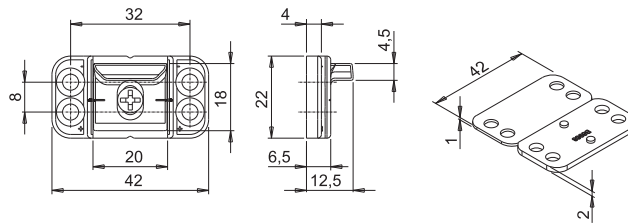
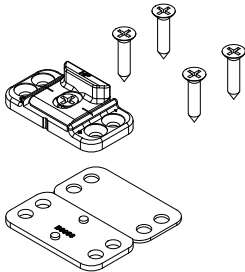

Item code	Description	Note	Base Raw	Anodised Elox	Painted	Trend/Gold Brass	Pieces per pack
01213	STRIKER FOR HP FLAT FRAMES	H= 12 mm	X				100
01214	STRIKER FOR HP FLAT FRAMES	H= 14 mm	X				100
01266K	CURTAIN WALL STRIKER	silver plus	X				100
01267K	CURTAIN WALL STRIKER WITH SHIM	silver plus	X				100
01269K	CURTAIN WALL ADJUSTABLE STRIKER	silver plus	X				100
01280	ADJUSTABLE STRIKER FOR FLAT FRAME		X				100

BURGLAR-PROOF FASTENING MECHANISM



Functions

Specially designed device to increase the resistance of the casement to break-in attempts, making intrusion through the window more difficult. Can be used on both sash and tilt-and-turn windows.

Online data sheet



04031K

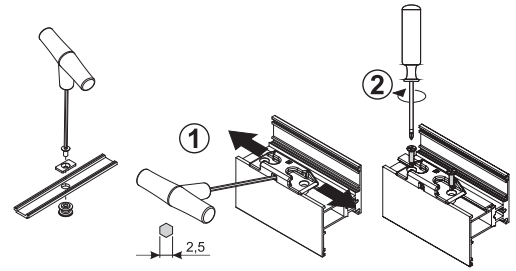
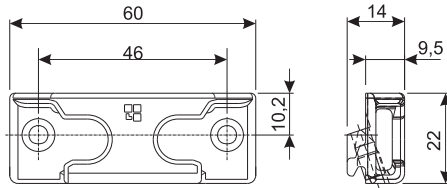
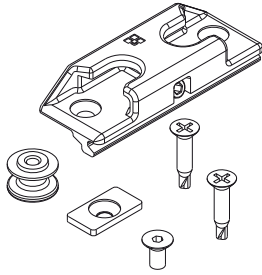

0404101

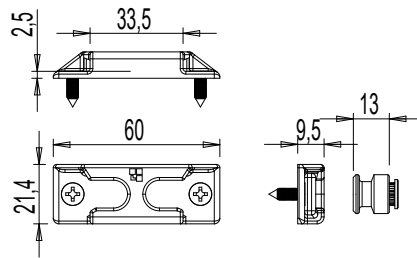
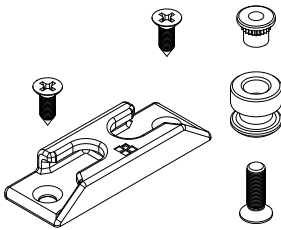

04046K

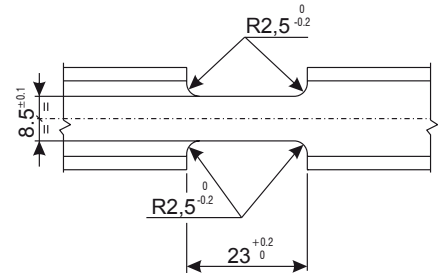
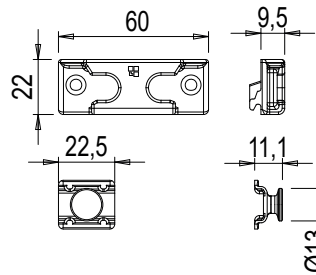
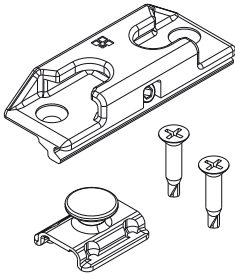

STRIKERS AND FASTENING MECHANISMS

Item code	Description	PROFILE CROSS - SECTION	Base Raw	Anodised Elox	Painted	Trend/Gold Brass	Pieces per pack
04031K	FUTURA BURGLAR-PROOF FASTENING MECHANISM	C001-C002-C003-C004-C005-C006-C011-C012-C013-C014-C015-C016-C017	X				20
0404101	BURGLAR-PROOF FASTENING MECHANISM	17 mm groove	X				20
04046K	BURGLAR-PROOF DEVICE	C001-C002-C003-C004-C005-C006-C011-C012-C013-C014-C015-C016-C017	X				20

MICRO-VENTILATION

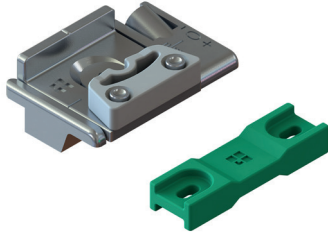

Functions

Adjustable device allowing precision opening of the casement, called "microventilation."

Online data sheet



02229K

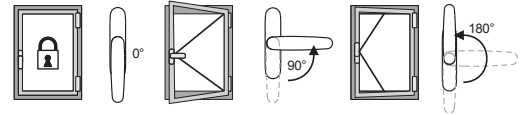
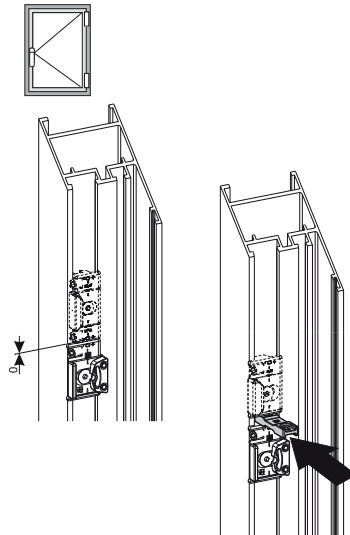
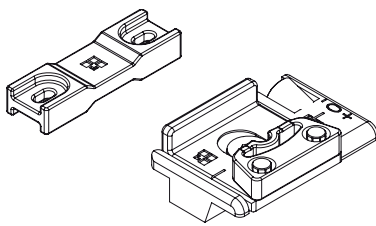

0223001

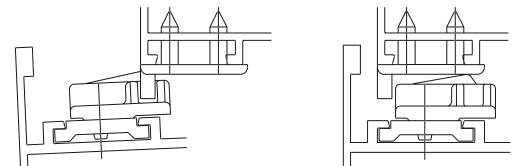
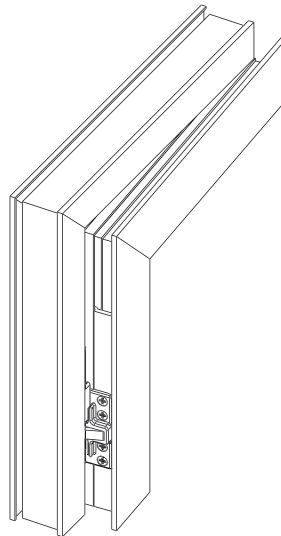
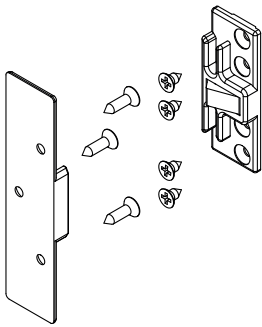

Item code	Description	PROFILE CROSS - SECTION	Base Raw	Anodised Elox	Painted	Trend/Gold Brass	Pieces per pack
02229K	FUTURA WINDOW MICROVENTILATION	C001-C002-C003-C004-C005-C006-C011-C012-C013-C014-C015-C016-C017	X				50
0223001	AERANTA	C001-C002-C004-C007-C011-C012-C013-C014-C015-C016-C017	X				50

CHIC FASTENING ELEMENTS



Functions

The fastening element can be used to create additional fastening mechanism on any aluminium sash, making the entire window structure sturdier. They are also compression adjustable.
Designed specifically for use with CHIC sash concealed hinges.

Online data sheet



CHIC

04358

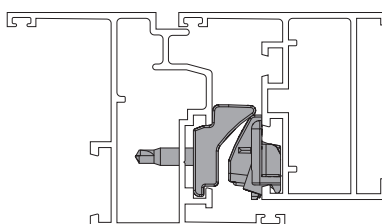
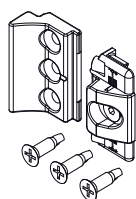

Compression adjustment

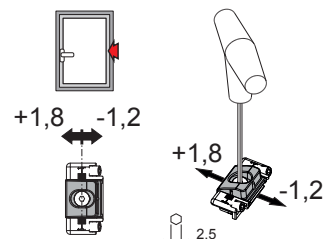

CHIC

05288

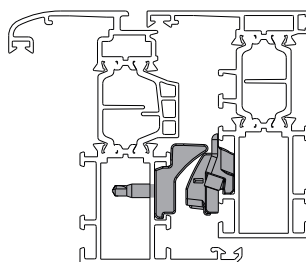
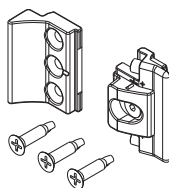

Compression adjustment

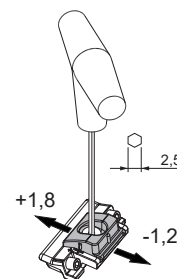

Item code	Description	PROFILE CROSS - SECTION	Can be combined with	Base Raw	Anodised Elox	Painted	Trend/Gold Brass	Pieces per pack
04358	ADJUSTABLE CHIC FASTENING ELEMENT	C001-C002-C003-C004-C005-C006	CHIC	X				50
05288	ADJUSTABLE CHIC FASTENING ELEMENT	C007	CHIC	X				25

BURGLAR BOLTS

Functions

The fastening element can be used to create additional fastening mechanism on any aluminium sash, making the entire window structure sturdier. They are also compression adjustable.

Designed specifically for use with traditional hinges (FLASH, FUTURA, etc.)

Online data sheet

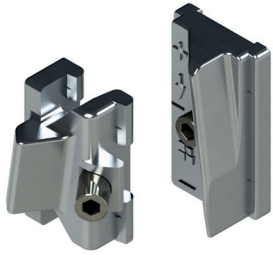

01350K

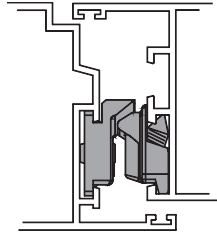
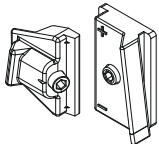

Compression adjustment

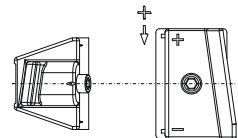

0135701

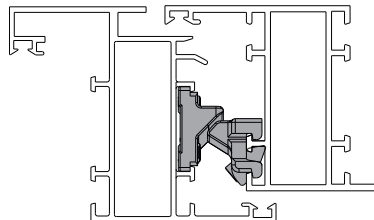
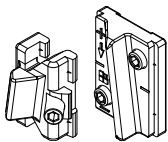

Compression adjustment

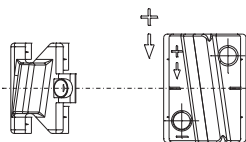

01391

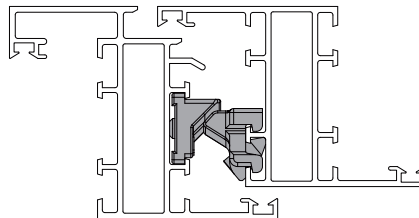
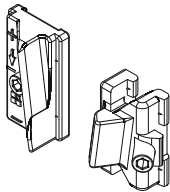

Compression adjustment

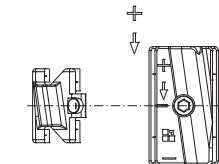

05294

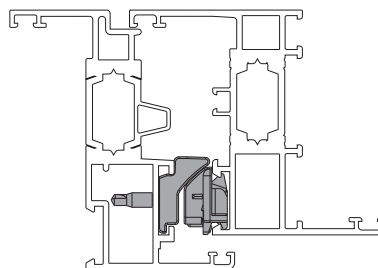
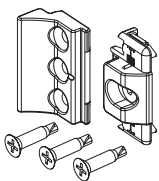

Compression adjustment

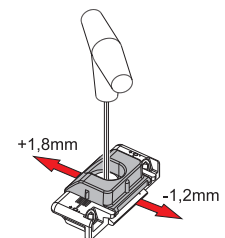

Item code	Description	PROFILE CROSS - SECTION	Can be combined with	Base Raw	Anodised Elox	Painted	Trend/Gold Brass	Pieces per pack
01350K	ADJUSTABLE FASTENING ELEMENT	C001-C002-C003-C004-C005-C006-C011-C012-C013-C014-C015-C016-C017	FLASH, FUTURA	X				50
0135701	ADJUSTABLE FASTENING ELEMENT	C008	FLASH, FUTURA, FULCRA, CELERA	X				50
01391	ADJUSTABLE FASTENING ELEMENT	C007	FLASH, FUTURA, FULCRA, CELERA	X				50
05294	ADJUSTABLE FASTENING ELEMENT	C001-C002-C003-C004-C005-C006-C011-C012-C013-C014-C015-C016-C017	FLASH, FUTURA, FULCRA, CELERA, EUROGROOVE ARMS	X				50

BURGLAR BOLTS FOR CURTAIN WALL FLAT FRAME

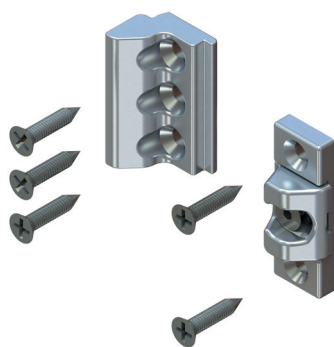

Functions

The fastening element can be used to create additional locking points on any aluminium sash, making the entire window structure sturdier.

Online data sheet



01410

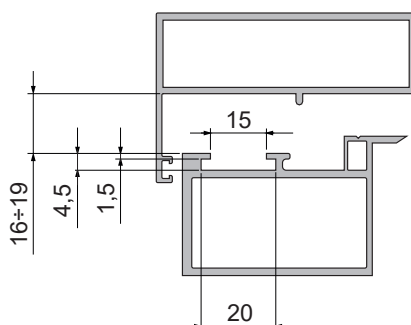
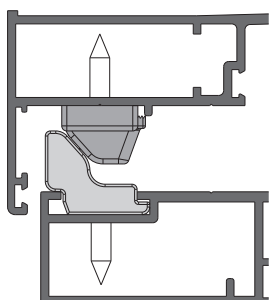
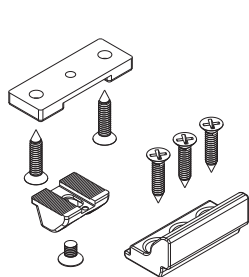

Compression adjustment

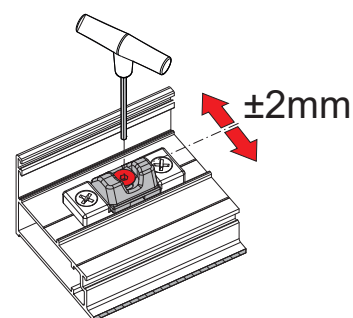

Item code	Description	Note	Base Raw	Anodised Elox	Painted	Trend/Gold Brass	Pieces per pack
01410	BURGLAR BOLT FOR CURTAIN WALL FOR 17 mm STACK	17 mm STACK	X				50

KIT FOR TWO-WAY SASH CLOSING

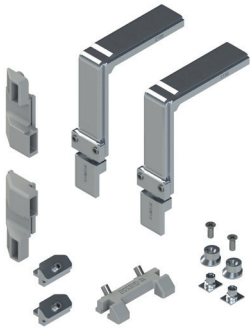

Functions

Two-way sash fastening mechanism. For use on casements that require side-hung sash opening.

[Online data sheet](#)



Technical Features

The sash fastening mechanism is available in different versions: fastening by pawls, fastening by Giap terminals, fastening by adjustable terminals and perimeter fastening by corner drives.

The fastening mechanism is to be in addition to the Euro or Prima Cremona and the Flash Base hinges.

Materials

Connecting blocks and raiser made of polyamide
Zamak fastening mechanism components
Screws and grub screws in stainless steel

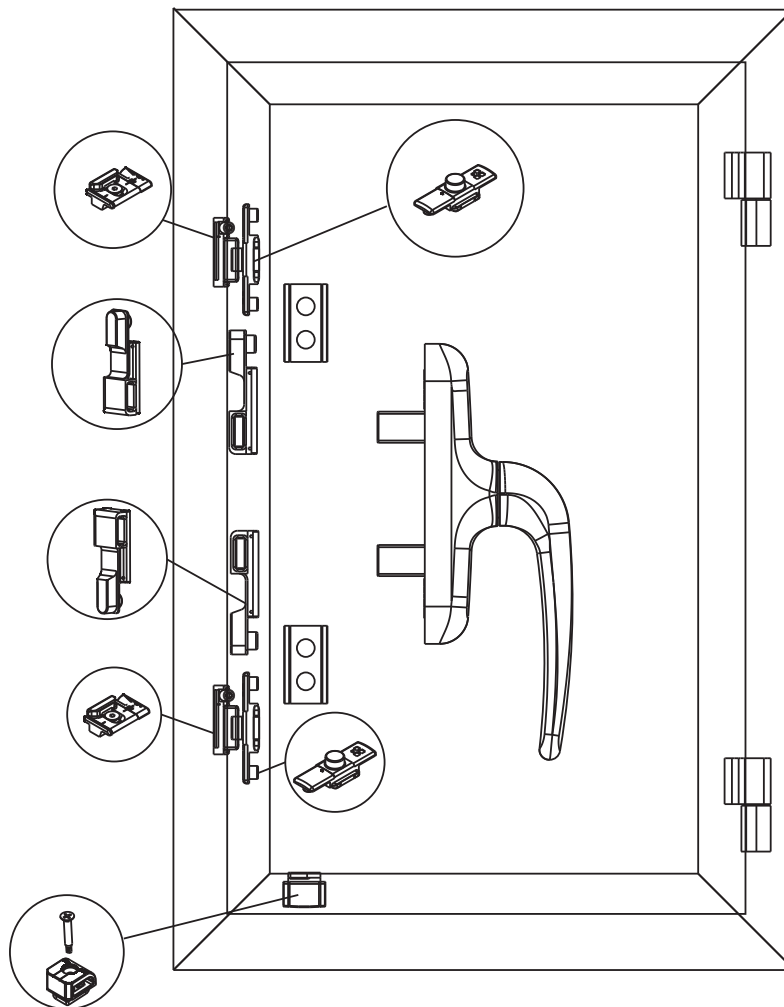

FASTENING SYSTEM

Item code	Description	PROFILE CROSS - SECTION	Bolt channel	Fastening mechanism with pawls	Fastening mechanism with Giap terminals	Fastening mechanism with Adjustable terminals	Perimetral Closing	Striker material	Base Raw	Anodised Elox	Painted	Trend/Gold Brass	Pieces per pack
01183K	SASH KIT WITH PROVEDAL TWO-WAY CLOSING	see Where Used Giesse	-	-	X	-	-	GS Silver Plus zamak			X		20
02129	SASH FASTENING SYSTEM	C007	15 ÷ 18	-	X	-	-	Black polyamide	X				40
02256K	SASH FASTENING SYSTEM	C001-C002-C003-C004-C005-C012-C013-C014-C015-C016-C017	-	-	X	-	-	GS Silver Plus zamak	X				20
02256N	SASH FASTENING SYSTEM	C001-C002-C003-C004-C005-C012-C013-C014-C015-C016-C017	-	-	X	-	-	GS500 zamak	X				20
02257	SASH FASTENING SYSTEM	C007	-	-	X	-	-	Black polyamide	X				20
02258K	FASTENER KIT FOR TWO GACS SASHES	C001-C002-C003-C004-C005-C012-C013-C014-C015-C016-C017	15 ÷ 20	-	X	-	-	Grey polyamide	X				20
02270	SASH FASTENING SYSTEM	C1-C2-C4-C11-C12-C13-C14-C15-C16-C17	-	-	X	-	-	Black polyamide	X				170
02270K	SASH FASTENING SYSTEM	C1-C2-C4-C11-C12-C13-C14-C15-C16-C17	-	-	X	-	-	Grey polyamide	X				170
02271	SASH FASTENING SYSTEM	C008	-	-	X	-	-	Black polyamide	X				110
02571K	KIT FOR SASH-PAWL CLOSING	C001-C002-C003-C005-C012-C013-C014-C015-C016-C017	-	X	-	-	-	GS Silver Plus zamak	X				10
02574K	KIT FOR SASH-GIAP TERMINAL CLOSING	C001-C002-C003-C005-C012-C013-C014-C015-C016-C017	-	-	X	-	-	GS Silver Plus zamak	X				10
02578K	KIT FOR SASH-PERIMETER CLOSING	C001-C002-C003-C005-C012-C013-C014-C015-C016-C017	-	-	-	-	X	GS Silver Plus zamak	X				10
02589K	ADDITIONAL FASTENER KIT	C001-C002-C003-C004-C012-C013-C014-C015-C016-C017	-	-	-	-	-	GS Silver Plus zamak	X				10



KIT FOR ONE-WAY SASH CLOSING

Functions

Kit for side-hung sash fastening mechanism complete with PRIMA cremone and FLASH BASE hinges.

Online data sheet



Technical Features

Kit comprising Cremone, hinges and fastening strikers allowing side-hung opening featuring a one-way fastening system.

A version is also available with a micro-ventilation device that enables gradual air recirculation.

Materials

Closing striker, microventilation striker, drive rod slider and connection element in zamak

Extruded aluminium hinges

Double striker and lifter in polyamide
Cremone fixing plate, cams and screws in stainless steel

Cremone handle in die-cast aluminium

Case, gear, slider and incorrect movement safety device in die-cast zamak

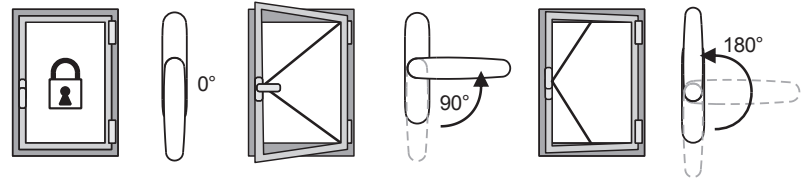
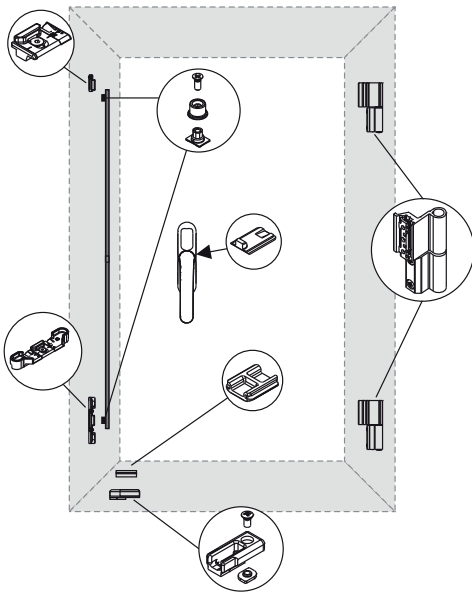

Item code	Description	PROFILE CROSS - SECTION	Pull handle 0°	Pull handle 90°	Pull handle 180°	Base Raw	Anodised Elox	Painted	Trend/Gold Brass	Pieces per pack
01181K	SASH KIT WITH ONE-WAY CLOSING	C007	Closed	open	-	X		X		20
01184K	SASH KIT WITH ONE-WAY CLOSING	C001	Closed	open	Micro-ventilation	X		X		20
01185K	SASH KIT WITH ONE-WAY CLOSING	C003	Closed	open	Micro-ventilation	X		X		20
01187	SASH KIT WITH ONE-WAY CLOSING	C001	-	-	-	X		X		20
01188	SASH KIT WITH ONE-WAY CLOSING	C003	-	-	-	X		X		20

MULTIPLE LOCK PIVOT KIT

Functions

Kit for making a multi-locking system for pivoting windows.

Online data sheet

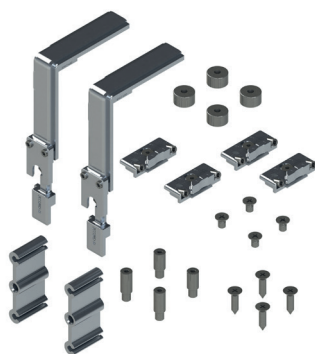

02197K

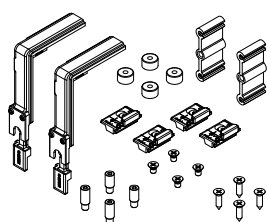

02223K

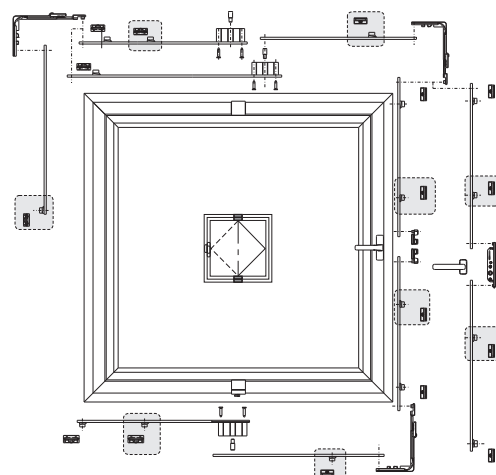
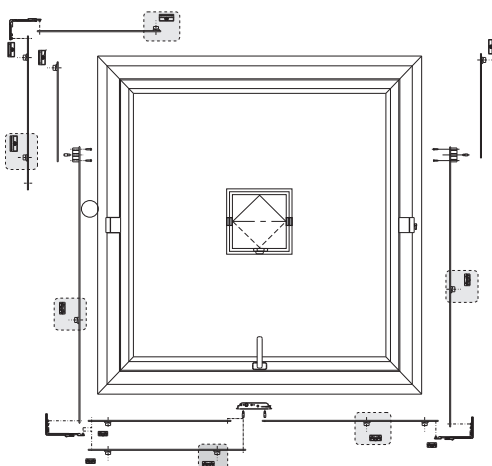
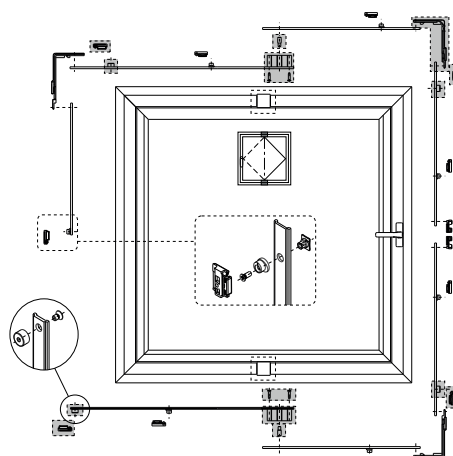
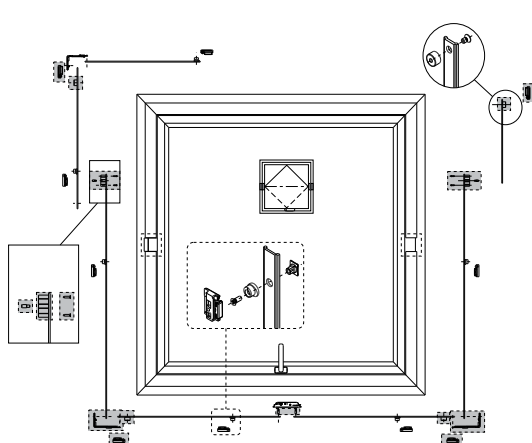

Item code	Description	PROFILE CROSS - SECTION	Base Raw	Anodised Elox	Painted	Trend/Gold Brass	Pieces per pack
02197K	PERIMETER FASTENER KIT	P001-P009	X				4
02223K	PERIMETER FASTENER KIT	P005	X				4



**CAP PLUGS
COMPENSATORS
CORNER JOINTS**

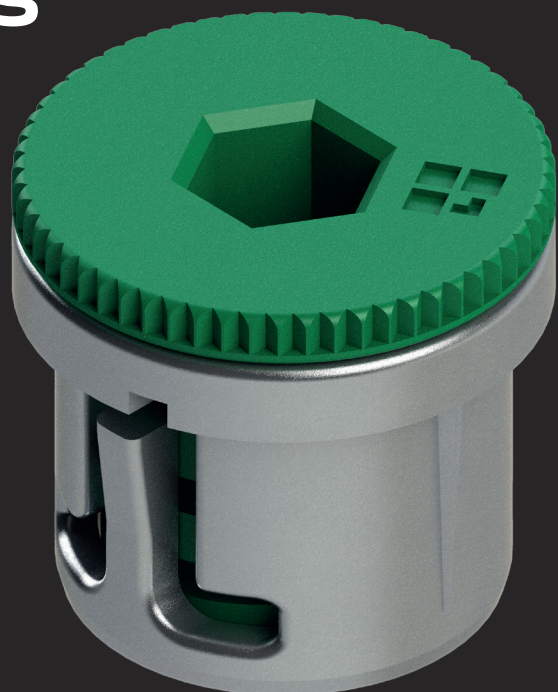

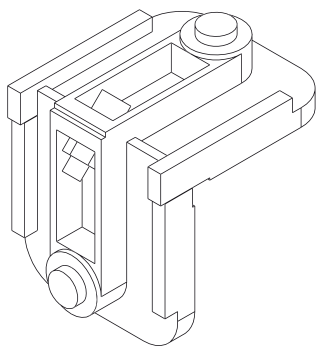

SNAP-MOUNTING CORNER JOINTS

Functions

Snap-mounting joint for assembling aluminium profiles on a corner.

[Online data sheet](#)



Technical Features

Corner joint with buttons dia. 10 mm.
The two spring-loaded buttons enable quick and secure assembly.
The closing screw and locknut makes for quick assembly of the parts.
Specific for joining profiles with 45° end cut.

Materials

Corner joint in die-cast aluminium with snap-mounting anchoring buttons.

Snap-mounting corner joint

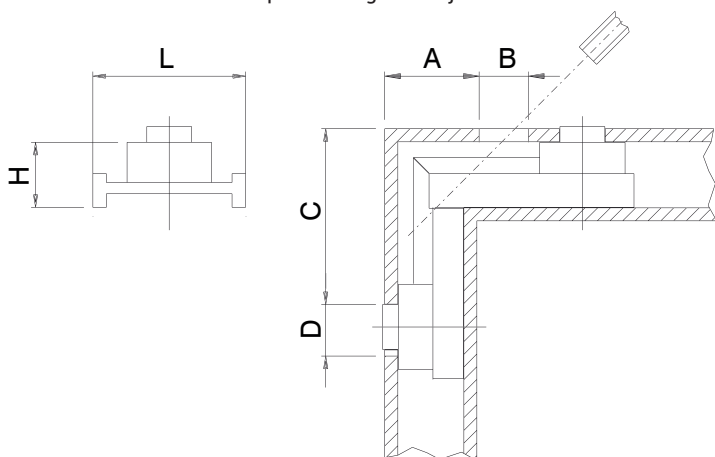

Item code	Description	L (mm)	H (mm)	A (mm)	B (mm)	C (mm)	D (mm)	Button	Centred button	Hand	Base Raw	Anodised Elox	Painted	Trend/Gold Brass	Pieces per pack
00305	SNAP-MOUNTING CORNER JOINT	36	14	21	11x6	41	10,5	External	Yes		X				250
00313	SNAP-MOUNTING CORNER JOINT	28,5	14,5	21	11x6	41,5	11,5	External	Yes		X				250
00367	SNAP-MOUNTING CORNER JOINT	28,5	34,8	26	13x8	47	10,5	External	Yes		X				200
06575	SNAP-MOUNTING CORNER JOINT	16,8	14,3	21	11x6	41	10	External	Yes		X				250

KAMEL SNAP-MOUNTING CORNER JOINTS

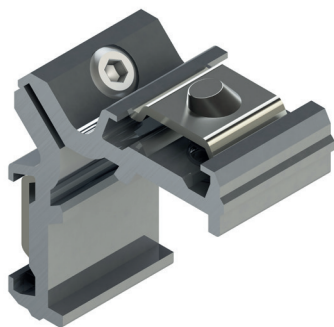

Functions

Snap-mounting joint for assembling aluminium profiles on a corner.

Online data sheet



Technical Features

Corner joint with external buttons dia. 10 mm
 The two spring-loaded buttons enable quick and secure assembly.
 The closing screw makes for quick assembly of the parts.
 Specific for joining profiles with 45° end cut.
 Oversized tubular sections need to be coupled with a shimming bracket (see table).

Materials

Extruded aluminium
 Screw in Geomet and buttons in steel with GS Silver Plus finish (over 500 hours of corrosion resistance)
 Springs in stainless steel

Parts

CSH screw M6x14.8

Kamel snap-mounting corner joint

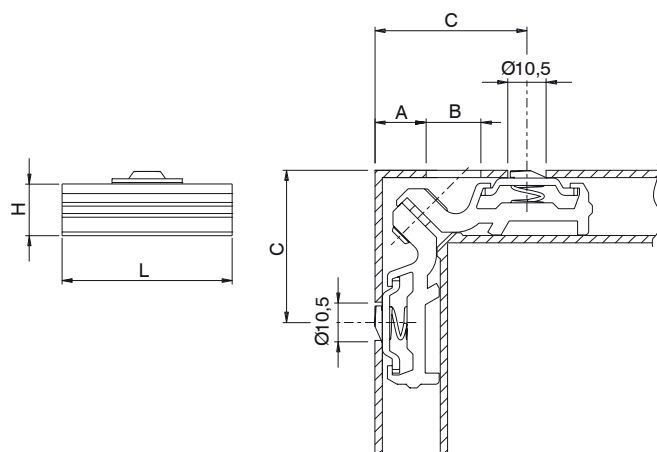

Shimming bracket

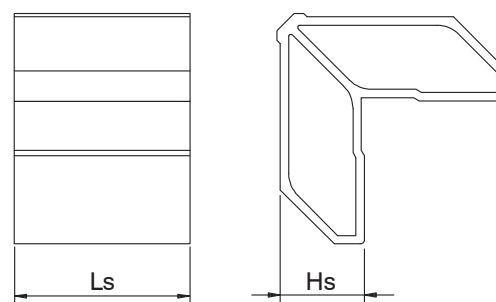

Item code	Description	L (mm)	H (mm)	A (mm)	B (mm)	C (mm)	Centred button	Shimming bracket	Ls (mm)	Hs (mm)	Base Raw	Anodised Elbox	Painted	Trend/Gold Brass	Pieces per pack
00332	KAMEL snap-mounting CORNER JOINT	20,2	14,1÷15,5	15	14x5	43	Yes	03602	20,2	16	X				250
00336	KAMEL snap-mounting CORNER JOINT	46	14,1÷15,5	14	14x5	42	Yes	00337	-	-	X				100
00337	SHIMMING BRACKET	-	-	-	-	-	-	-	46	23,7	X				100
00338	KAMEL snap-mounting CORNER JOINT	28,5	14,1÷15,5	14	14x5	43	No	00339	-	-	X				50
00339	SHIMMING BRACKET	-	-	-	-	-	-	-	28,5	23,7	X				100
00340	KAMEL CORNER JOINT + SHIMMING BRACKET	40,9	37,8÷39,2	15	14x5	43	Yes	-	41,1	21,7	X				50
00344	KAMEL snap-mounting CORNER JOINT	28,5	14,1÷15,5	14	14x5	37,25	Yes	00339	28,5	23,7	X				100
00349	SHIMMING BRACKET	-	-	-	-	-	-	-	34,5	23,7	X				100
00357	KAMEL snap-mounting CORNER JOINT	33,9	14,1÷15,5	14	14x5	43	Yes	-	33,9	21,7	X				100

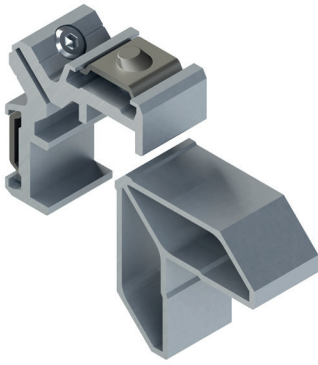

KAMELDUE SNAP-MOUNTING CORNER JOINTS

Functions

Snap-mounting joint for assembling aluminium profiles on a corner.

Online data sheet



Technical Features

Corner joint with external buttons dia. 10 mm.
The two spring-loaded buttons enable quick and secure assembly.
The closing screw makes for quick assembly of the parts.
Specific for joining profiles with 45° end cut.
For oversized profiles a shimming bracket is available.

Materials

Body in extruded aluminium
Screw in Geomet and buttons in steel with GS Silver Plus finish (over 500 hours of corrosion resistance).
Springs in stainless steel

Parts

CSH screw M6x14.8

Kameldue snap-mounting corner joint

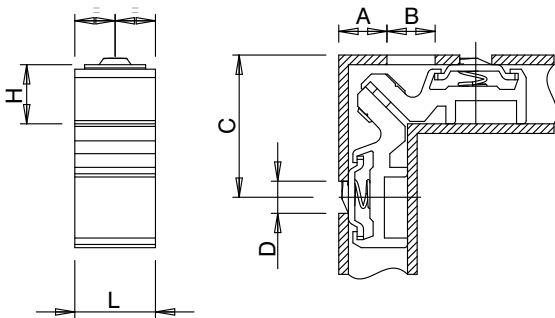

Shimming bracket

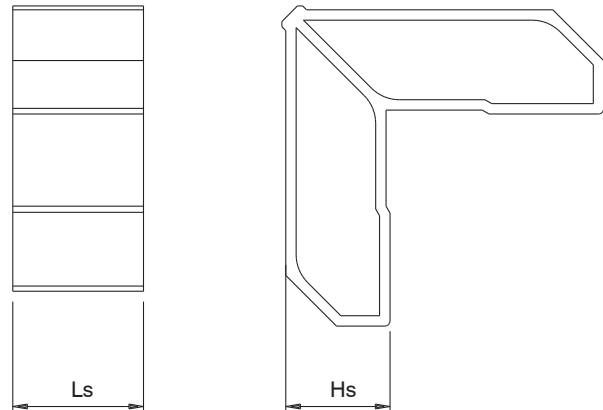

Item code	Description	L (mm)	H (mm)	A (mm)	B (mm)	C (mm)	D (mm)	Centred button	Ls (mm)	Hs (mm)	Base Raw	Anodised Elox	Painted	Trend/Gold Brass	Pieces per pack
00330	KAMELDUE snap-mounting CORNER JOINT	25,1	17,4÷18,5	15	14x5	43	10,5	Yes	-	-	X				100
00335	SHIMMING BRACKET	-	-	-	-	-	-	-	25,1	20	X				100

KAPPA SNAP-MOUNTING CORNER JOINTS

**Functions**

Joining element, for corner connection of aluminium profiles.

Online data sheet

**Technical Features**

Corner joint with internal buttons dia. 10mm.

Made entirely of steel.

The closing screw makes for quick assembly of the parts.

Specific for joining profiles with 45° end cut.

Materials

Body, corner guide, expansion spring and screw in zinc plated steel.

Parts

HSH screw M6x16

Kappa snap-mounting corner joint

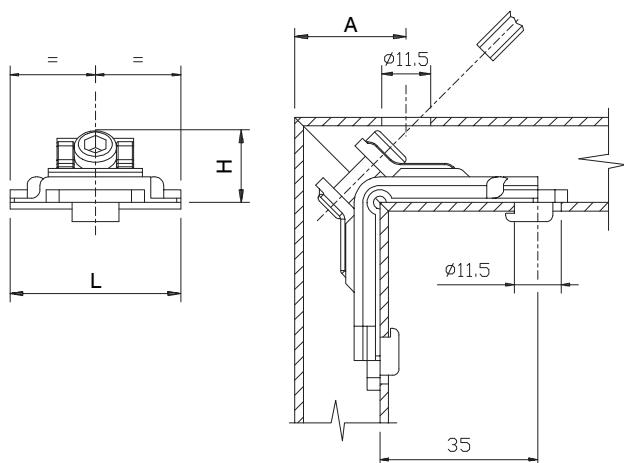

Item code	Description	L (mm)	H (mm)	A (mm)	Base Raw	Anodised Elox	Painted	Trend/Gold Brass	Pieces per pack
00321010	KAPPA steel CORNER JOINT	35,5	MIN.14.5	25	X				200
00322010	KAPPA steel CORNER JOINT	41	MIN.14.5	see Where Used Giesse	X				200
00323010	KAPPA steel CORNER JOINT	45	MIN.14.5	see Where Used Giesse	X				200

CORNER JOINTS

REX SNAP-MOUNTING CORNER JOINTS

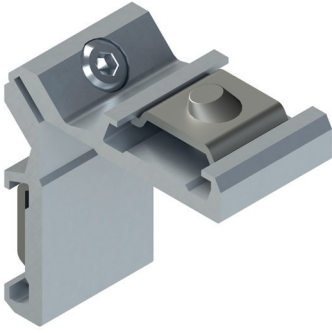

Functions

Snap-mounting joint for assembling aluminium profiles on a corner.

[Online data sheet](#)



Technical Features

Corner joint with external buttons dia. 10 mm.
The two spring-loaded buttons enable quick and secure assembly.
The closing screw makes for quick assembly of the parts.
Specific for joining profiles with 45° end cut.

Materials

Body in extruded aluminium
Screw in Geomet and buttons in steel with GS Silver Plus finish (over 500 hours of corrosion resistance)
Springs in stainless steel

Parts

CSH screw M6 x 14.8

Rex snap-mounting corner joint

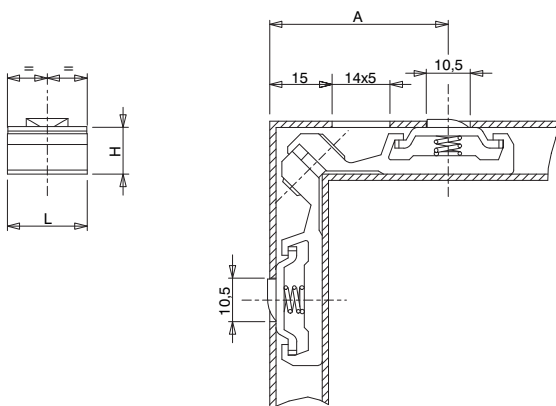

Shimming bracket

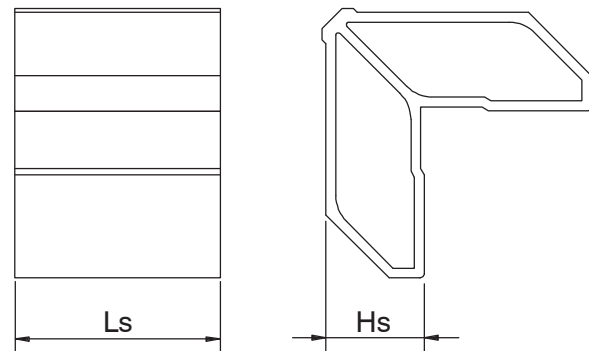

Item code	Description	L (mm)	H (mm)	A (mm)	Matching products	Ls (mm)	Hs (mm)	Base Raw	Anodised Elox	Painted	Trend/Gold Brass	Pieces per pack
00325	REX snap-mounting CORNER JOINT	19,2	10,3÷11,2	42÷43	-	-	-	X				250
00326	REX snap-mounting CORNER JOINT	28,5	10,3÷11,2	42÷43	-	-	-	X				250
00334	SHIMMING BRACKET	-	-	-	00356	30,4	23,7	X				100
00350	REX snap-mounting CORNER JOINT	41	10,3÷11,2	42÷43	-	-	-	X				250
00351X	REX snap-mounting CORNER JOINT	24	10,3÷11,2	42÷43	-	-	-	X				250
00352	REX snap-mounting CORNER JOINT	22,4	10,3÷11,2	43	-	-	-	X				250
00353	REX snap-mounting CORNER JOINT	19,5	10,3÷11,2	42÷43	-	-	-	X				250
00355	REX snap-mounting CORNER JOINT	26	10,3÷11,2	42÷43	-	-	-	X				250
00356	REX snap-mounting CORNER JOINT	35,7	10,3÷11,2	42÷43	00334	-	-	X				250



SCREW CORNER JOINTS

Functions

Joining element for corner connection of aluminium profiles.

[Online data sheet](#)



Technical Features

Specific for joining profiles with 45° end cut.
Very sturdy and reliable, they enable locking the corners perfectly and solidly.

Materials

Extruded aluminium body, zinc plated bolt and nut.

Screw corner joint

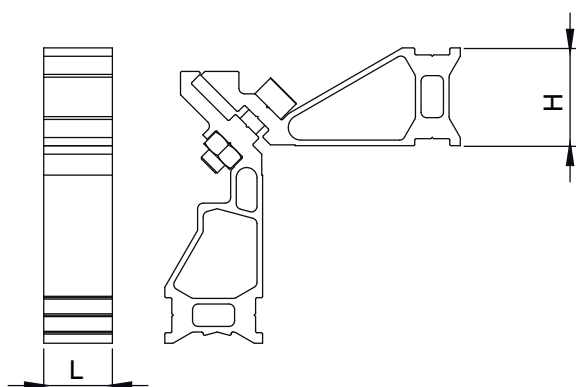

Item code	Description	L (mm)	H (mm)	Pair	Base Raw	Anodised Elox	Painted	Trend/Gold Brass	Pieces per pack
00397	CORNER JOINT FOR SCREWING ON	28,5	34,9	Yes	X				10
00398	CORNER JOINT FOR SCREWING ON	45,8	34,9	No	X				20
06791	CORNER JOINT FOR SCREWING ON	28,1	9,6	No	X				50

MULTIFUNCTION CORNER JOINT

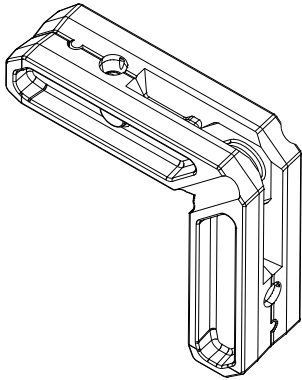

Functions

Joining element for corner connection of aluminium profiles.

Online data sheet



Technical Features

Multipurpose corner joint: for screwing (in combination with certain screws), pinning or crimping with special grooves for the glue to run along.

Materials

Die-cast aluminium

Tightening with screw: (1) outward opening (2) inward opening

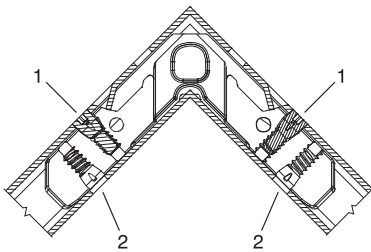

Tightening with crimping

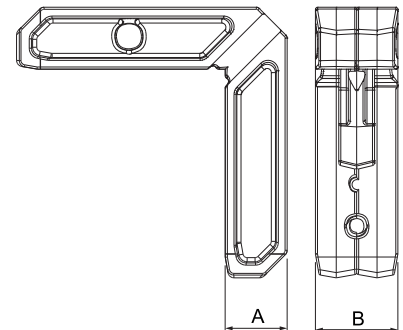
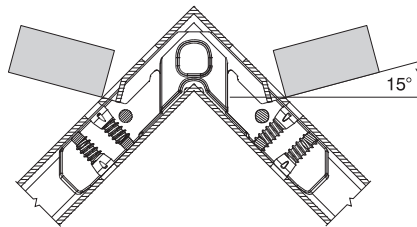

Item code	Description	A (mm)	B (mm)	Can be combined with	Base Raw	Anodised Elox	Painted	Trend/Gold Brass	Pieces per pack
06521	SCREW M5X14_D8	14	Ø8	06532, 06533, 06534, 06535	X				1000
06523	SCREW M5X12.5_ST	12	Ø8		X				1000
06532	MULTI-FUNCTIONAL CORNER JOINT	14,4	23	06521	X				200
06533	MULTI-FUNCTIONAL CORNER JOINT	14,3	16,8	06521	X				200
06534	MULTI-FUNCTIONAL CORNER JOINT	14,8	26,4	06521	X				200
06535	MULTI-FUNCTIONAL CORNER JOINT	14,5	19,5	06521	X				200

ALIGNMENT CORNER JOINTS

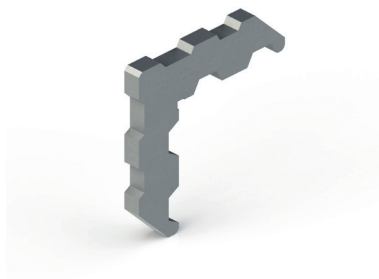

Functions

Pressure fitting corner joints which join and align the walls.

Online data sheet



Technical Features

Required to align the walls once the window/door has been assembled.
Quick and easy press-fitting design.

Alignment corner joint

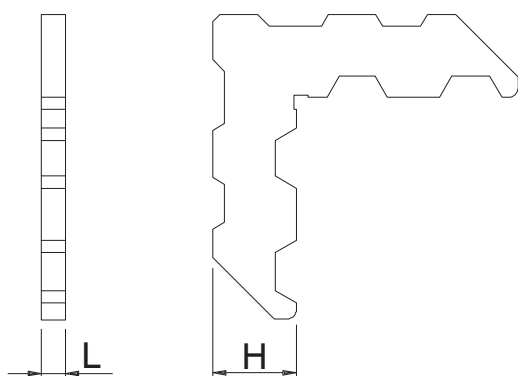

Item code	Description	L (mm)	H (mm)	Material	Notes	Base Raw	Anodised Elox	Painted	Trend/Gold Brass	Pieces per pack
00360	ALIGNMENT CORNER JOINT	5,1	17,5	Aluminium	-	X				100
00362	ALIGNMENT CORNER JOINT	5,1	37,5	Aluminium	-	X				100
00363	ALIGNMENT CORNER JOINT	5,1	10	Aluminium	-	X				100
00365	ALIGNMENT CORNER JOINT	1,7	4,7	Stainless Steel	-	X				1000
00366	ALIGNMENT CORNER JOINT	6	26,5	Polyamide	-	X				200
01224	ALIGNMENT CORNER JOINT	3,6	16,1	Polyamide	-	X				200
02368	ALIGNMENT CORNER JOINT	2,8	14,2	Polyamide	-	X				200
02380	ALIGNMENT CORNER JOINT	3,2	34,6	Polyamide	-	X				200
03463	ALIGNMENT CORNER JOINT	1,8	17,4	Polyamide	-	X				200
06528	ALIGNMENT CORNER JOINT	4,1	19,3	Aluminium	-	X				250
06529	ALIGNMENT CORNER JOINT	4,1	16,3	Aluminium	-	X				250
06579	ALIGNMENT CORNER JOINT	4,8	16,2	Aluminium	-	X				250

ALEX STEEL T-JOINTS



Functions

Head joint for the T-connection of extruded aluminium profiles, quick to mount and secure.

Online data sheet



Technical Features

Drilled and tapped M6.
The coupling nib forms a single body with its structure (exploiting the features of the KAPPA corner joint).
The plate spring supplied allows safe and rapid positioning.
Since the T-joint is clamping, it is locked on tightening the M6 screw not supplied.

Materials

Body of zinc plated steel
Spring in hardened steel.

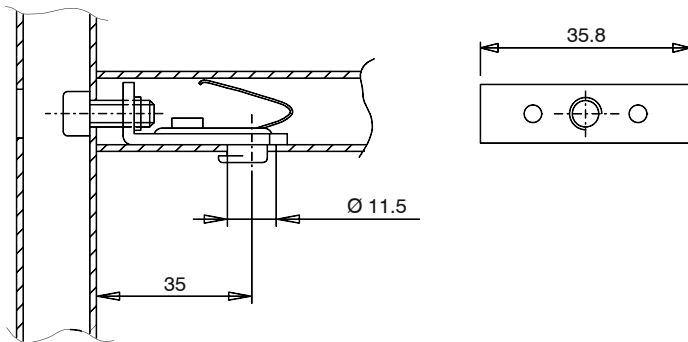

Item code	Description	Note	Base Raw	Anodised Elox	Painted	Trend/Gold Brass	Pieces per pack
00471	ALEX STEEL T-JOINT	35.8x14 mm	X				100

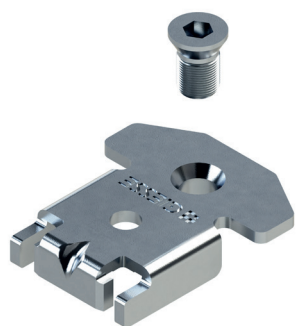

ROBUR STEEL T-JOINTS

Functions

Head joint for the cross and T-connection of extruded aluminium profiles, quick to mount and secure.

Online data sheet



Technical Features

Since the T-joint is clamping, it is locked on tightening the screw. Using two opposing T-joints enables cross-joining the profiles.

Materials

Body and closing screw in zinc plated steel

Parts

1 Closing screw M8x13

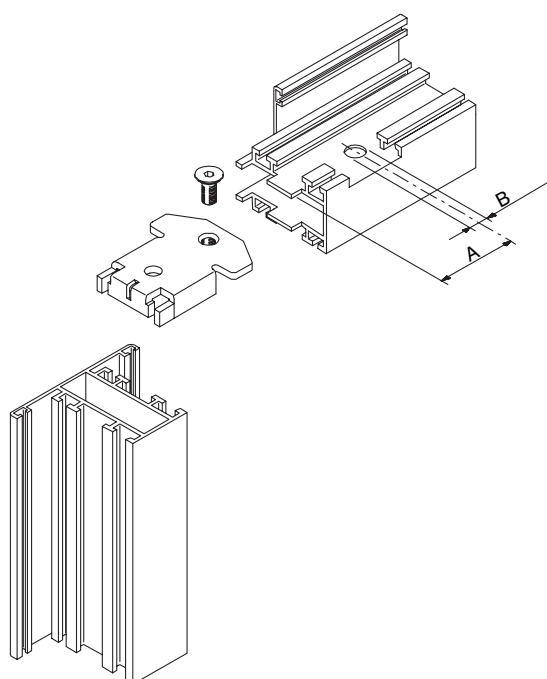

Item code	Description	A (mm)	B (mm)	Base Raw	Anodised Elox	Painted	Trend/Gold Brass	Pieces per pack
00476	ROBUR T-JOINT	35	10,5	X				100
00477	ROBUR T-JOINT	35	10,5	X				100
00481	ROBUR T-JOINT	35	11,5	X				50

EXTRUDED ALUMINIUM T-JOINTS

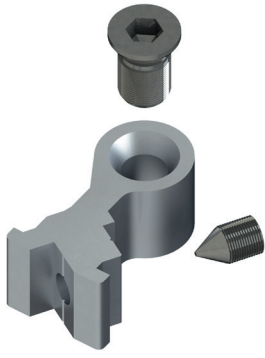

Functions

Head joint for the cross and T-connection of extruded aluminium profiles, quick to mount and secure.

[Online data sheet](#)



Technical Features

Joint for the cross and T-connection of extruded aluminium profiles, quick to mount and secure.

They are equipped with a special pull screw that prevents any interference with the glazing bead.

Materials

Body in extruded aluminium.

Zinc plated steel screw.

Zinc plated steel grub screw.

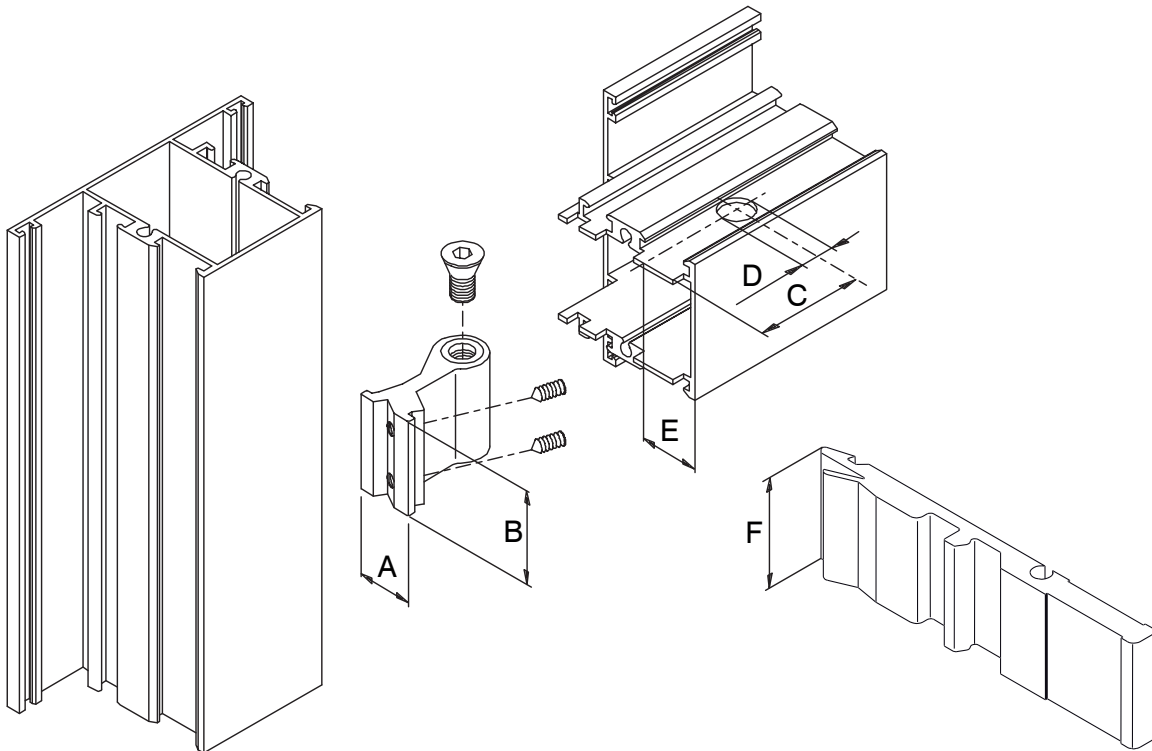

Item code	Description	A (mm)	B (mm)	C (mm)	D (mm)	E (mm)	F (mm)	Notes	Base Raw	Anodised Elox	Painted	Trend/Gold Brass	Pieces per pack
00420	EXTRUDED ALUMINIUM T-JOINT	30,7	14,15	33	11,5	-	-	-	X				100
00425	EXTRUDED ALUMINIUM T-JOINT	17,5	14,7	33	11,5	14,5	-	-	X				100
00428N	EXTRUDED ALUMINIUM T-JOINT	17,5	14,1	27,5	10,5	11,7	-	-	X				100
00429	EXTRUDED ALUMINIUM T-JOINT	17,5	10,7	27,5	10,5	11,6	-	-	X				100
00430N	EXTRUDED ALUMINIUM T-JOINT	17,5	20	27,5	10,5	11,6	-	-	X				100
00431	EXTRUDED ALUMINIUM T-JOINT	17,5	31,35	27,5	10,5	11,8	-	-	X				50
00432	EXTRUDED ALUMINIUM T-JOINT	17,5	17,55	33,3	10,5	14,5	-	-	X				100
00443	EXTRUDED ALUMINIUM T-JOINT	-	-	-	-	-	102,5	Pin	X				100
00474	EXTRUDED ALUMINIUM T-JOINT	29,4	13,9	35	10,5	20,5	-	-	X				100
00475N	EXTRUDED ALUMINIUM T-JOINT	29,4	37,5	35	10,5	20,5	-	-	X				50
00479	EXTRUDED ALUMINIUM T-JOINT	34,2	38	35	10,5	20,5	-	-	X				50
00484	EXTRUDED ALUMINIUM T-JOINT	19,5	10,45	33	10,5	-	-	-	X				100
00485	EXTRUDED ALUMINIUM T-JOINT	38,6	10,5	33	10,5	-	-	-	X				100
00486	EXTRUDED ALUMINIUM T-JOINT	38,7	10	35	10,5	-	-	-	X				100
00487	EXTRUDED ALUMINIUM T-JOINT	43,7	14,5	35	10,5	-	-	-	X				100
89989	EXTRUDED ALUMINIUM T-JOINT	18,4	10,5	22,5	10,5	11,7	-	-	X				100

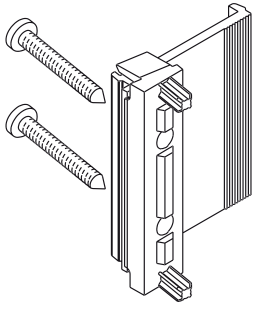

FIXING BRACKET

Functions

Wall fixing bracket, surface-mounting, for normal and insulating windows.

[Online data sheet](#)



Materials

Bracket in extruded aluminium
Fibreglass reinforced polyamide shims
Zinc plated steel screws.

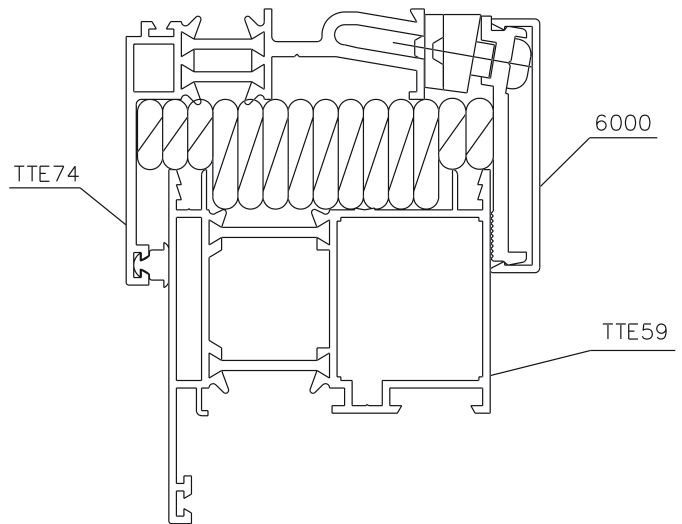
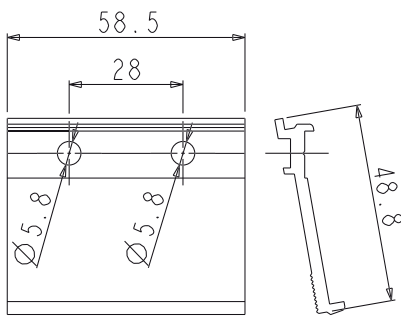

Item code	Description	Note	Base Raw	Anodised Elox	Painted	Trend/Gold Brass	Pieces per pack
01228	FIXING BRACKET	to the wall	X				50

FIXING ADAPTER

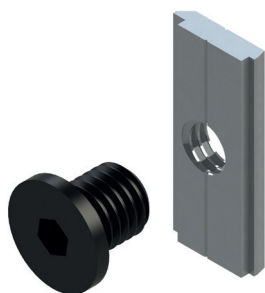

Functions

Movable rule to compensate for the tolerances between the iron counter-frame and the aluminium frame to be inserted in the frame on the outer side.

Online data sheet



Technical features

Once the casement has been set in the specific compartment, take the pull screws to rest on the iron counter-frame and correctly position the casement. To do this, use an Allen wrench CH6.

Materials

Extruded aluminium base
Pull screw in black polyamide.

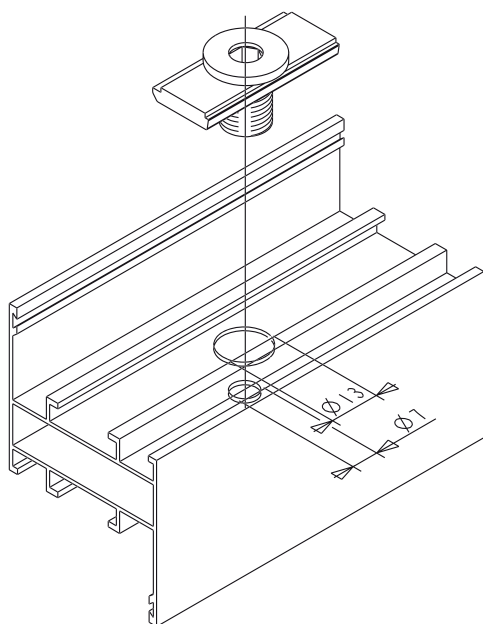

Item code	Description	Note	Base Raw	Anodised Elox	Painted	Trend/Gold Brass	Pieces per pack
02319	FIXING ADAPTER		X				100

MINCIO FIXING ADAPTER

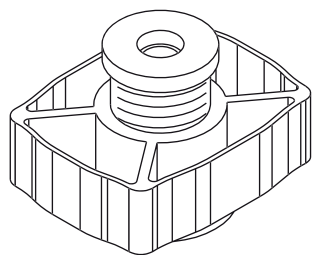

Functions

Movable rule to compensate for the tolerances between the iron counter-frame and the aluminium frame to be inserted in the frame on the outer side.

Online data sheet



Technical features

Specific for sections 40x18/20, 50x20 and 50x25.

Once the casement has been set in the specific compartment, take the pull screws to rest on the iron counter-frame and correctly position the casement. To do this, use an Allen wrench CH6.

Materials

Body and screw in black polyamide.

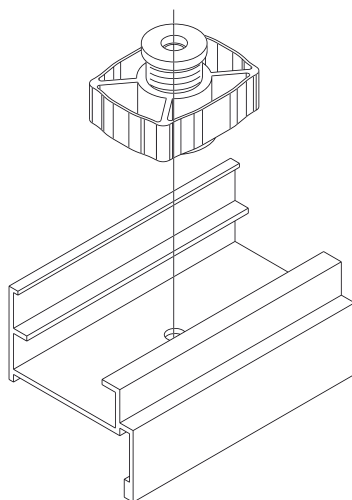

Item code	Description	Note	Base Raw	Anodised Elox	Painted	Trend/Gold Brass	Pieces per pack
02326	MINCIO FIXING ADAPTER	screw 40x18/20 mm - mm 50x20/25	X				100



FIXING ADAPTER

Functions

Movable rule to compensate for the tolerances between the iron counter-frame and the aluminium frame to be inserted in the frame on the outer side.

Online data sheet



Technical features

Once the casement has been set in the specific compartment, take the pull screws to rest on the iron counter-frame and correctly position the casement. To do this, use an Allen wrench CH6.

Materials

Zinc plated zamak plate
Black polyamide screw

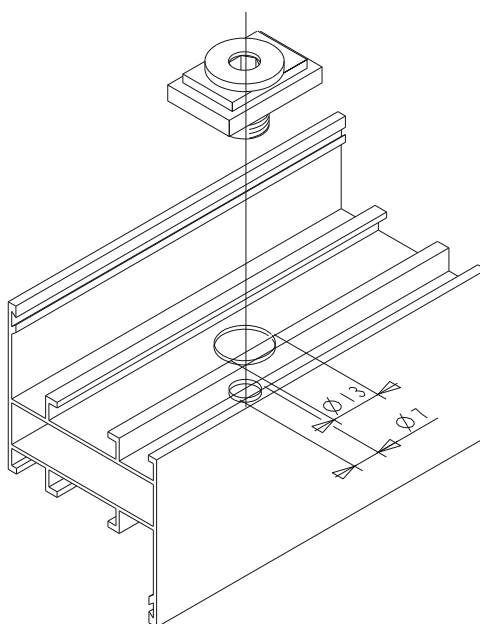

Item code	Description	Note	Base Raw	Anodised Elox	Painted	Trend/Gold Brass	Pieces per pack
02365	FIXING ADAPTER		X				200

SKATTO FIXING ADAPTER



Functions

The SKATTO adjustable compensator is the smartest solution for fixing between the aluminium counter-frame and the masonry work, compensating for the existing tolerances between the two items.

Online data sheet



Technical features

SKATTO is quick to install and easy to adjust.

Materials

Housing in Zamak
Adjustment screw in polyamide reinforced with fibreglass.

Machining Art. 06500

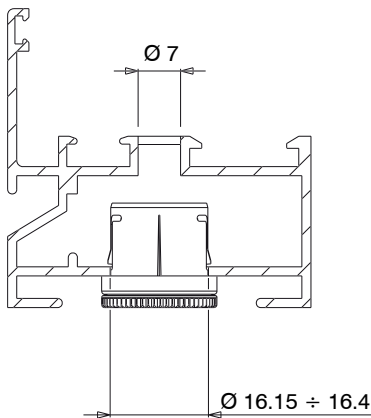

Machining Art. 06501

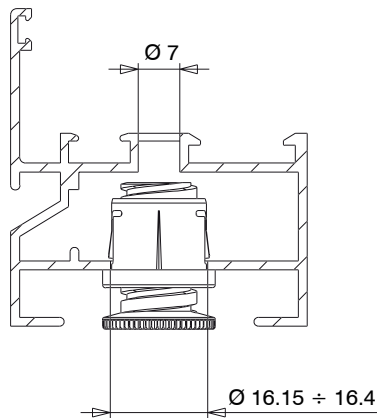

Machining Art. 06502

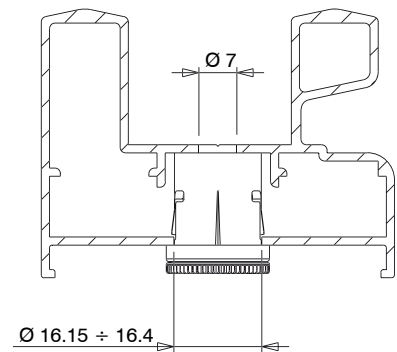

Dimensions Art. 06500

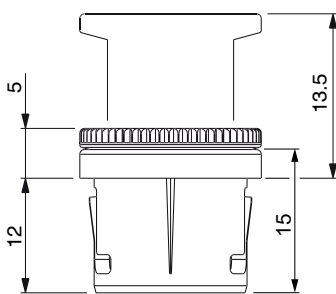

Dimensions Art. 06501

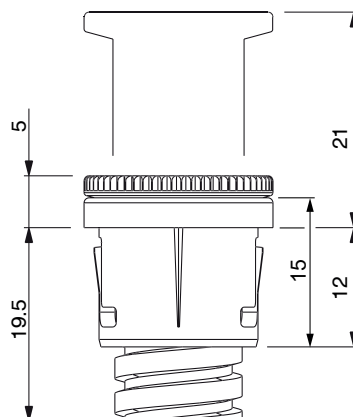

Dimensions Art. 06502

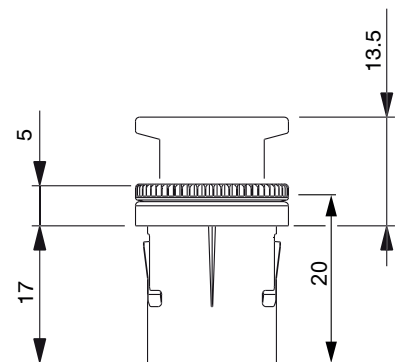

Item code	Description	Length of screw (mm)	Height of the housing (mm)	Base Raw	Anodised Elox	Painted	Trend/Gold Brass	Pieces per pack
06500	SKATTO FIXING ADAPTER	17,2	15	X				500
06501	SKATTO FIXING ADAPTER	24,7	15	X				500
06502	SKATTO FIXING ADAPTER	17,2	20	X				500

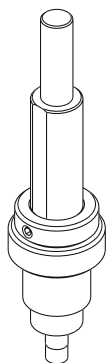

SKATTO COMPENSATOR TOOL

Functions

Tool used to do the machining for mounting the SKATTO compensator.

[Online data sheet](#)



Technical features

It consists of an adjustable counterbore and an adjustable stop.
Counterbore tool with 2 diameters, one for fixing the compensator $\varnothing 16.2$ and one for the screw passage $\varnothing 7$.

Materials

Tool body made of special steel
Adjustable counterbore made of special steel
Adjustable stop made of treated steel
2 Flat-tipped stainless steel grub screws M 5 x 5.

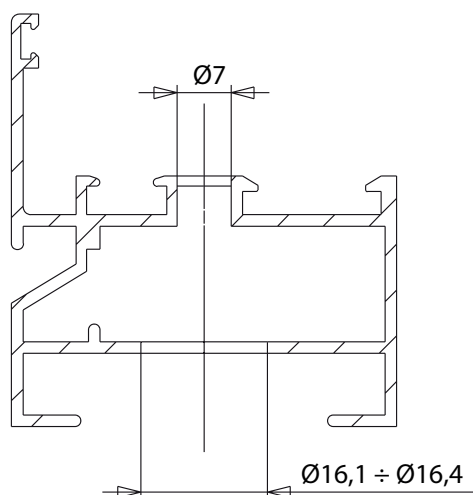

Item code	Description	Note	Base Raw	Anodised Elox	Painted	Trend/Gold Brass	Pieces per pack
06510	SKATTO COMPENSATOR TOOL		X				1

SHIMMING WASHER

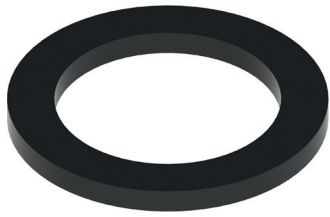

Functions

Shim washer to be used in conjunction with the Giesse hinges, when required.

Online data sheet



Materials

Polyamide

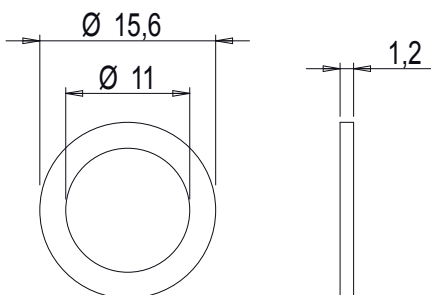

Item code	Description	Note	Base Raw	Anodised Elox	Painted	Trend/Gold Brass	Pieces per pack
02301	SHIMMING WASHER		X				100

CORNER COVER PLUG

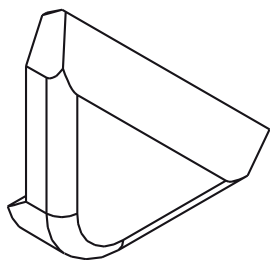

Functions

Polyamide component to be glued in the corners of the sashes to cover sharp edges.

Online data sheet



Materials

Black polyamide

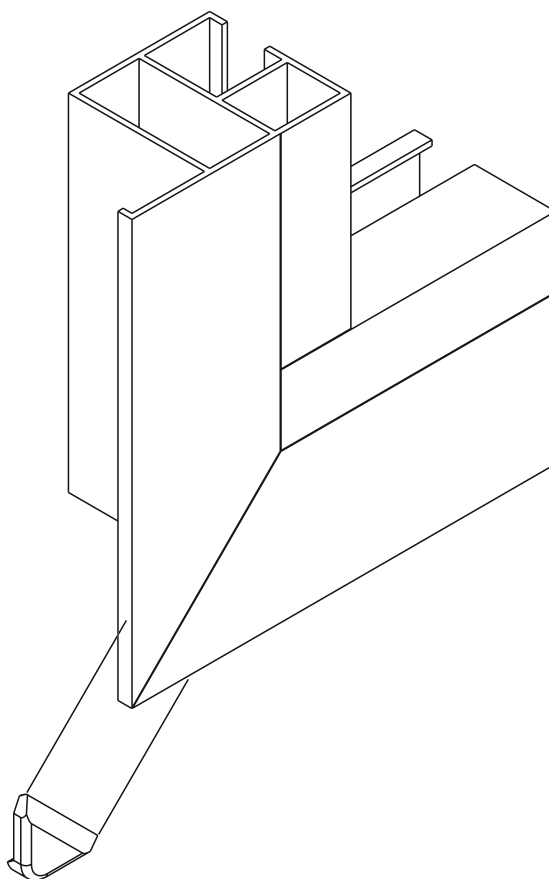

Item code	Description	Note	Base Raw	Anodised Elox	Painted	Trend/Gold Brass	Pieces per pack
02394	CORNER COVER PLUG	black polyamide	X				500

GLAZING BEAD CLIP



Functions
Glazing bead clip.

Online data sheet



Materials
Black polyamide

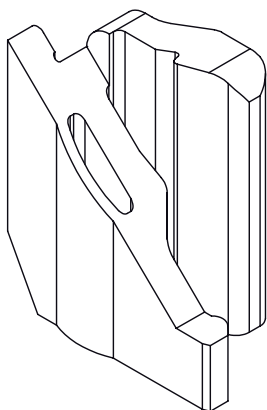

Item code	Description	Note	Base Raw	Anodised Elox	Painted	Trend/Gold Brass	Pieces per pack
0086401	GLAZING BEAD CLIP	35,5 mm	X				100

CAPS



Functions

Polyamide part with snap fitting, to be used for covering the drain slot.

Online data sheet



Technical Features

The drain cap has a quick-fit snap-fix fastener, on the special machinings in the figure.

Enables the water in the groove to be drained off quickly outside the room. The particular shape of the cap and the presence of an internal valve (when fitted) allow an optimal run-off of water even under conditions of strong external pressure caused by the wind.

Materials

Black polyamide

Machining art. 01261

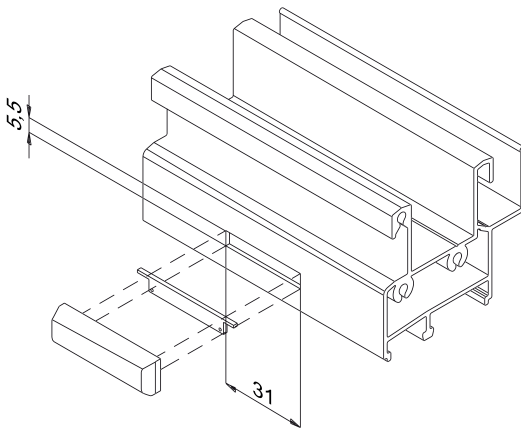

Machining art. 02282

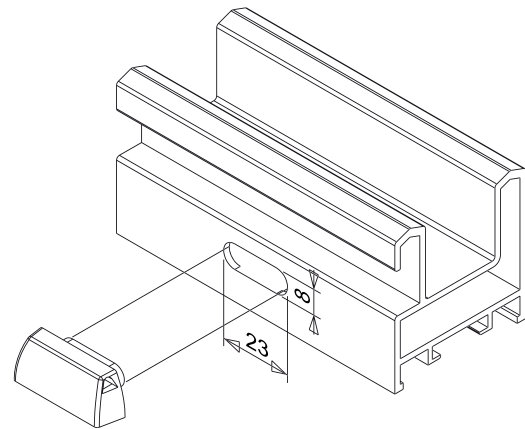

Machining art. 02314

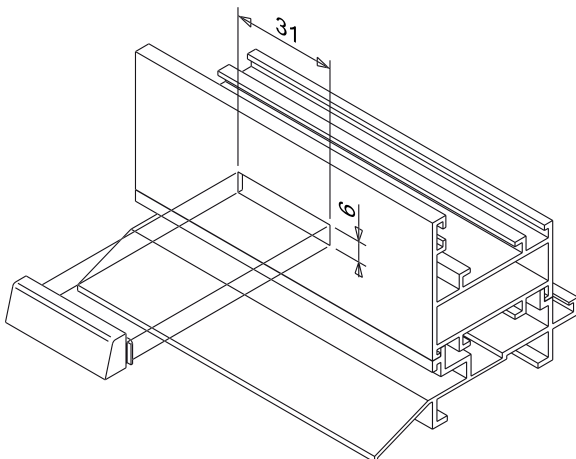

Machining art. 02328

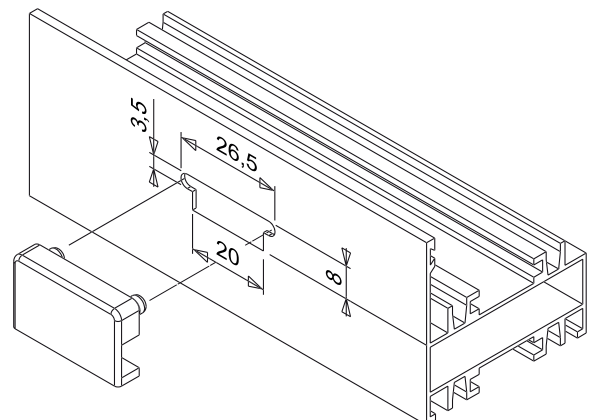

VARIOUS COMPONENTS

Machining art. 02354

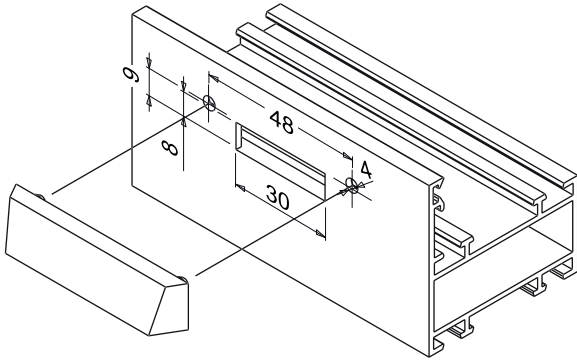

Machining art. 02357

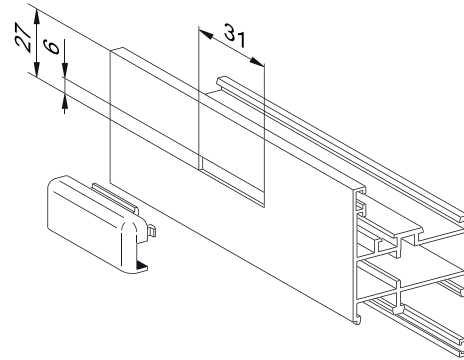

Machining art. 02359

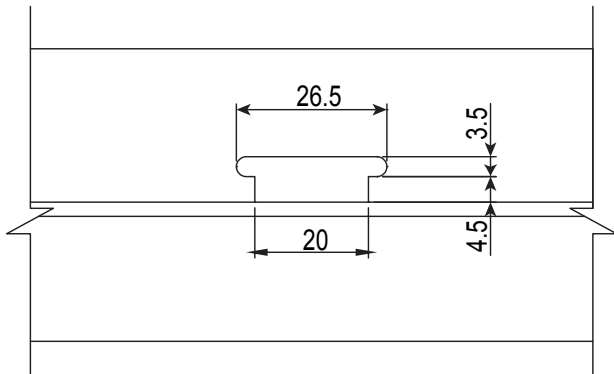

Machining art. 02360

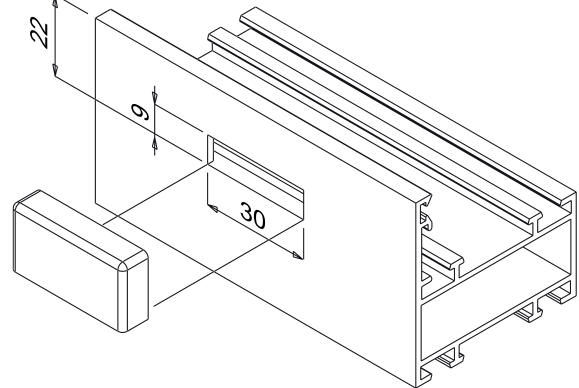

Machining art. 03149

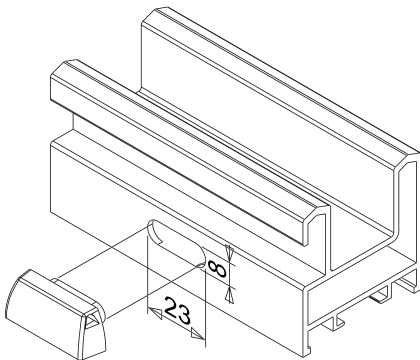

Bushing in combination with art. 03149

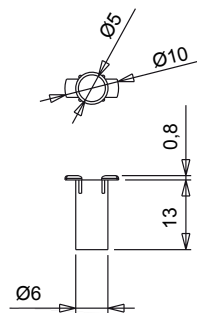

Machining art. 03195

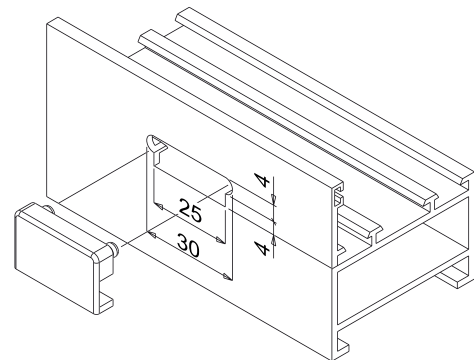

Item code	Description	Note	Material	Base Raw	Anodised Elox	Painted	Trend/Gold Brass	Pieces per pack
01261	DRAINAGE HOLE CAP	with valve	Black polyamide	X				100
02282	DRAINAGE HOLE CAP	with valve	Black polyamide	X				50
02314	DRAINAGE HOLE CAP		Black polyamide	X				1000
02328	DRAINAGE HOLE CAP		Black polyamide	X				1000
02354	DRAINAGE HOLE CAP		Black polyamide	X				1000
02357	DRAINAGE HOLE CAP		Black polyamide	X				1000
02359	DRAINAGE HOLE CAP		Black polyamide	X				1000
02360	DRAINAGE HOLE CAP		Black polyamide	X				1000
03149	DRAINAGE HOLE CAP	with pallet drain bushing and valve	Black polyamide	X				50
03195N	DRAINAGE HOLE CAP		Black polyamide	X				1000

SASH SUPPORT PLUGS

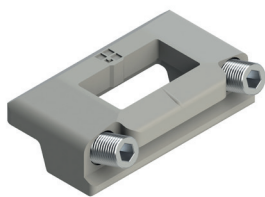

Functions

Component used for restoring the position of the sash during closing by sliding against the series striker.

Online data sheet



Technical Features

Used in combination with the corner drive, it shifts the weight of the sash during closing off the hinges and restores the sash to its theoretical position when it is closed.

Essential for proper isolation of the room from atmospheric agents.

01355K

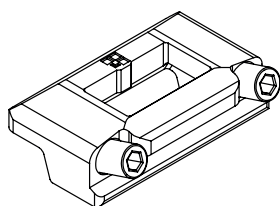

01717

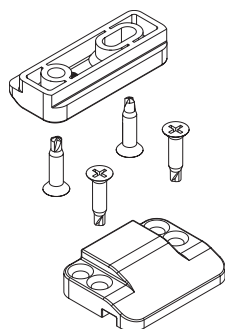

02196

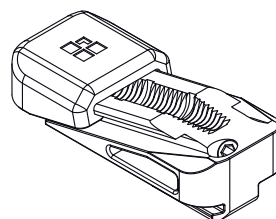

02309

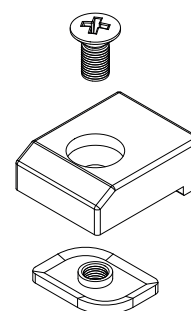

02336

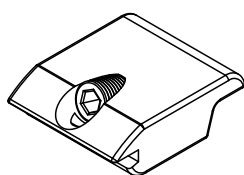

02352

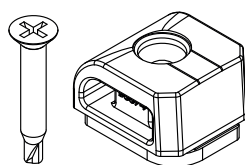

02366

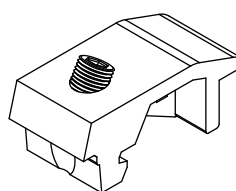

02390

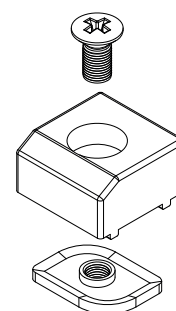

Item code	Description	PROFILE CROSS - SECTION	Base Raw	Anodised Elox	Painted	Trend/Gold Brass	Pieces per pack
01355K	SASH RAISER STRIKER	C001-C002-C003-C004-C005-C006-C011-C012-C013-C014-C015-C016-C017	X				100
01717	CENTER SAH RAISER	17 mm STACK	X				100
02196	ADJUSTABLE SASH RAISER	C001-C002-C003-C004-C005-C006-C011-C012-C013-C014-C015-C016-C017	X				100
02309	SASH SUPPORT PLUG	C009	X				100
02336	SASH SUPPORT PLUG	C001-C002-C003-C004-C005-C006-C011-C012-C013-C014-C015-C016-C017	X				500
02352	SASH LIFTING COMPONENT	C001-C002-C003-C004-C005-C011-C012-C013-C014-C015-C016-C017	X				100
02366	SASH SUPPORT PLUG	C007 - C008	X				200
02390	SASH SUPPORT PLUG		X				100

CONDENSATE PLUGS



Functions

Pair of caps for condensation trap and/or drip profiles for aluminium windows.

Online data sheet



Technical Features

Black polyamide components to be used as infill of the ends of the condensation trap profile and/or drip profile, for press-fitting and lock with adhesives.

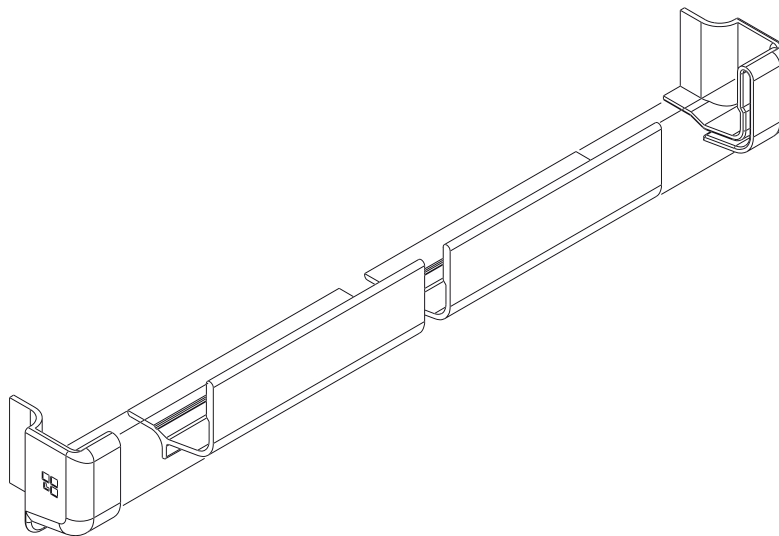

Item code	Description	Note	Base Raw	Anodised Elox	Painted	Trend/Gold Brass	Pieces per pack
03203	CONDENSATE PLUGS	right+left	X				50

HOLE PLUGS



Functions

Component made for closing holes.

Online data sheet



Technical Features

Enables concealing unsightly machining on the profile and protects your fingers from any burrs.

Materials

Black rubber

02331

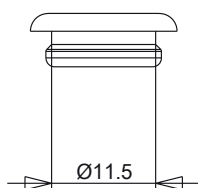
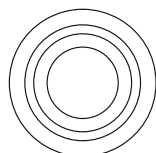

02332

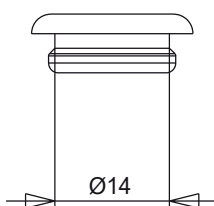
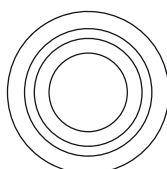

Item code	Description	Note	Base Raw	Anodised Elox	Painted	Trend/Gold Brass	Pieces per pack
02331	HOLE PLUG	diameter 11.5 mm -black	X				500
02332	HOLE PLUG	diameter 14 mm -black	X				500

 **GIESSE**

ARMS

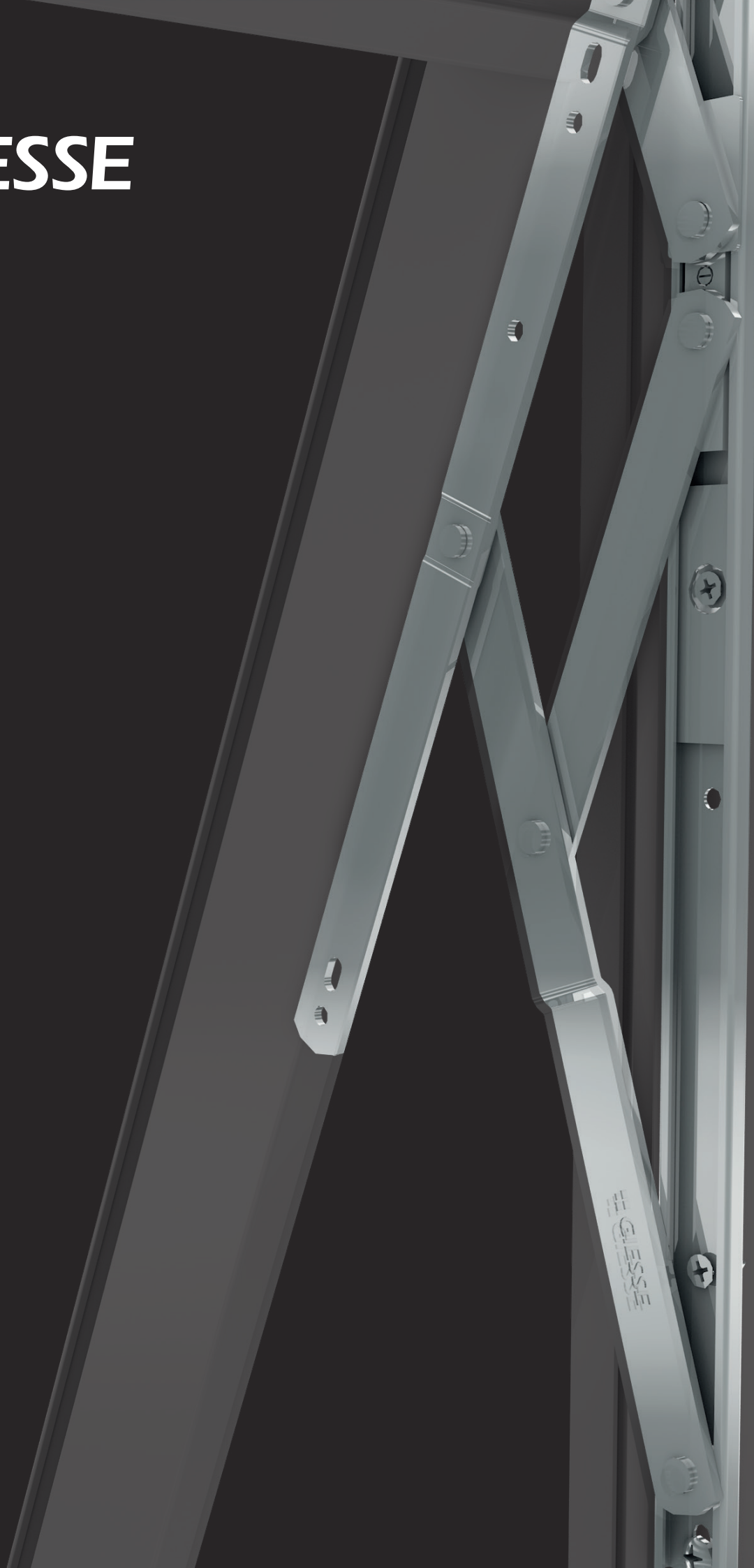

ARMS FOR CURTAIN WALL-TOP HUNG-SIDE HUNG WINDOWS

GS HD ARMS TYPE A



Functions

Two-handed self-balancing arms able to bear the weight of a top-hung or outward opening (side hung) window and hold it in the open position.

Online data sheet



Technical Features

Type-A GS HD arms are suitable for making medium – low size/weight top or side hung windows (see table).

Some models can be used on both these different outward opening casement types (see table).

Type-A GS HD arms can be frictioned by turning the grub screw on the slider. They can be applied in combination with the I, L and Laser limitation arms; this is in order to limit the maximum opening of a Top Hung sash.

Type-A GS HD arms are tested by Giesse for up to life-time 30.000 cycles.

Applicability

Type-A GS HD arms are applicable to sets of profiles with a stack (sash / frame distance) of 16 mm.

Materials

AISI 304 stainless steel

Top Hung (A: internal, B: external)

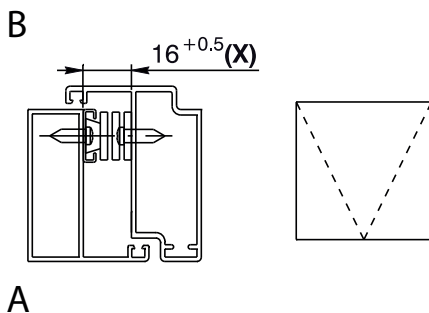

Side Hung (A: internal, B: external)

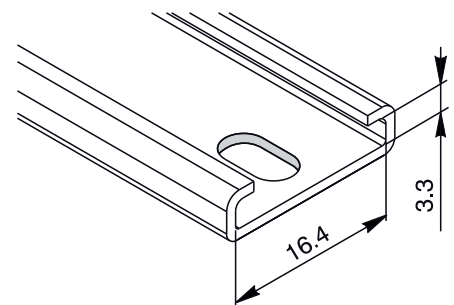
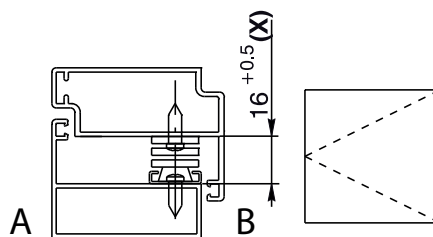

ARMS FOR CURTAIN WALL-TOP HUNG-SIDE HUNG WINDOWS

Item code	Description	Permitted type of opening	Bag width	Arm thickness (mm)	Arm length (mm)	TOP HUNG Maximum opening angle	TOP HUNG Maximum height (mm)	TOP HUNG Maximum width (mm)	TOP HUNG Maximum weight (kg)	SIDE HUNG Maximum height (mm)	SIDE HUNG Maximum width (mm)	SIDE HUNG Maximum weight (kg)	Base Raw	Items per pack
08127N	GS HD - 10" type A	Top-Side	18	15,5+0,5	261	84	400	1200	16	1200	550	14	X	6
08128N	GS HD - 12" type A	Top-Side	18	15,5+0,5	305	85	550	1200	18	1200	600	16	X	6
08130N	GS HD - 16" type A	Top-Side	18	15,5+0,5	407	87	750	1200	21	1200	600	20	X	6
08133N	GS HD - 22" type A	Top	18	15,5+0,5	563	40	1100	1200	-	-	-	-	X	6

ARMS FOR CURTAIN WALL-TOP HUNG-SIDE HUNG WINDOWS

GS HD ARMS TYPE M



Functions

Pair of self-balancing arms (one right and one left) able to bear the weight of a top hung window or outward opening (side hung) window and hold it in the open position.

Online data sheet



Technical Features

Type-M GS HD arms are suitable for making medium – low size/weight top or side hung windows.

Some models can indeed be used on both these different outward opening casement types (see table).

Since the upper part of the arm is asymmetrical, within the pair of arms we will have a right and a left; this asymmetrical geometry of the arm improves the return and closing phases of the sash.

Type-M GS HD arms can be frictioned by turning the grub screw on the slider. If necessary, type-M GS HD arms can be applied in combination with the N-type limitation arms; this is in order to limit the maximum opening of a Top Hung sash.

Type-M GS HD arms are tested by Giesse for up to life-time 30.000 cycles.

Applicability

Type-M GS HD arms are applicable to sets of profiles with a stack (sash/frame distance) of 14 mm.



Ask to your sales rep for product availability.

Materials

AISI 304 stainless steel arm
Slider in polyamide and brass

Top Hung (A: internal, B: external)

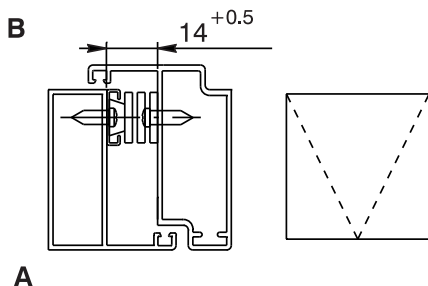

Side Hung (A: internal, B: external)

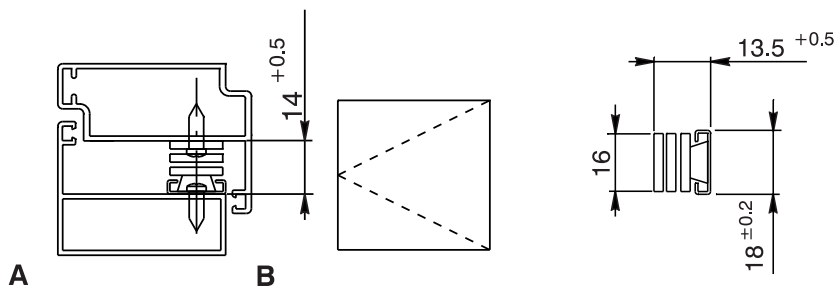

Item code	Description	Permitted type of opening	Bag width (mm)	Arm thickness (mm)	arm length (mm)	Maximum opening angle	Top Hung maximum height (mm)	Top Hung maximum width (mm)	Top Hung Maximum Weight (kg)	Side Hung maximum height (mm)	Side Hung maximum width (mm)	Side Hung Maximum Weight (kg)	Base Raw	Items per pack
08195	GS HD - 12" type M	Top-Side	18	13,5+0,5	310	87	550	1200	20	1200	600	16	X	6
08196	GS HD - 14" type M	Top-Side	18	13,5+0,5	358	87	650	1200	22	1200	600	17	X	6
08197	GS HD - 16" type M	Top-Side	18	13,5+0,5	412	87	750	1200	24	1200	650	20	X	6
08198	GS HD - 18" type M	Top-Side	18	13,5+0,5	459	87	850	1200	26	1200	650	21	X	6
08201	GS HD - 8" type M	Top	18	13,5+0,5	214	70	350	1200	12				X	6
08202	GS HD - 10" type M	Top-Side	18	13,5+0,5	270	87	400	1200	16	1200	550	15	X	6

GS HD ARMS TYPE C



Functions

Pair of self-balancing arms (one right and one left) able to bear the weight of an outward opening side-hung window and hold it in the open position.

Online data sheet



Technical Features

Type-C GS HD arms are suitable for medium size/weight outward opening side hung windows (see table).

Since the upper part of the arm is asymmetrical, within the pair of arms we will have a right and a left; this asymmetrical geometry of the arm improves the return and closing of the sash.

The window opening can also be frictioned by turning the grub screw on the slider.

The EGRESS articles ensure a wider passageway with the sash open, increasing the space for egress, compared to a normal arm type C. These articles do not allow cleaning the glass on the outside.

Art. LOOSE RIVET requires a minimum force for opening and closing the sash.

Art. EASY CLEAN integrates the EGRESS function with the possibility of cleaning the window also on the outside, as it is possible, from time to time, to move the sash sideways and create an opening. After cleaning the outside of the window the arm is put back into its normal working condition.

Type-C GS HD arms are tested by Giesse for up to life-time 30.000 cycles.

Applicability

Type-C GS HD arms are applicable to profiles with a stack (sash/frame distance) of 16.5 - 17 mm.



Ask to your sales rep for product availability.

Materials

AISI 304 stainless steel arm

Slider in polyamide and 304 grade stainless steel

Side Hung (A: internal, B: external)

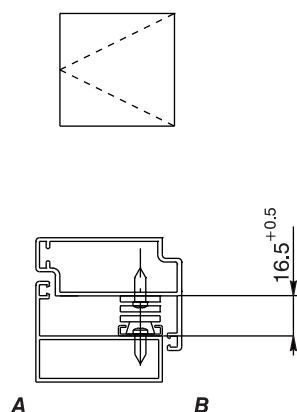

Unlocking element for cleaning the outside of the sash

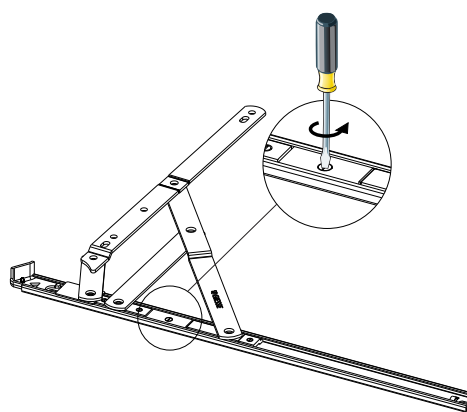

Item code	Description	Permitted type of opening	Egress	Loose rivet	Bag width	Sash - frame distance (mm)	arm length (mm)	Maximum opening angle	Side Hung maximum height (mm)	Side Hung maximum width (mm)	Side Hung Maximum Weight (kg)	Side adjustment	Base Raw	Items per pack
0814701	GS HD - 10" type C	Side	NO	NO	23	16,5+0,5	263	82	1600	550	36	/	X	6
0814901	GS HD - 14" type C	Side	NO	NO	23	16,5+0,5	365	87	1600	650	40	/	X	6
0815101	GS HD - 16" type C	Side	NO	NO	23	16,5+0,5	414	87	1600	700	42	/	X	6
0815201	GS HD - 18" type C	Side	NO	NO	23	16,5+0,5	463	87	1600	750	45	/	X	6

ARMS FOR CURTAIN WALL-TOP HUNG-SIDE HUNG WINDOWS

GS HD ARMS TYPE C PLUS



Functions

Pair of self-balancing arms (one right and one left) able to bear the weight of an outward opening side-hung window and hold it in the open position.

Online data sheet



Technical Features

Type-C Plus GS HD arms are suitable for medium size/weight outward opening (side hung) casement windows (see table).

Since the upper part of the arm is asymmetrical, within the pair of arms we will have a right and a left; this asymmetrical geometry of the arm improves the return and closing of the sash.

The window opening can also be frictioned by turning the grub screw on the slider.

Type-C Plus GS HD arms are tested by Giesse for up to life-time 30.000 cycles.



Ask to your sales rep for product availability.

Materials

AISI 304 stainless steel arm

Slider in polyamide and 304 grade stainless steel

Side Hung (A: internal, B: external)

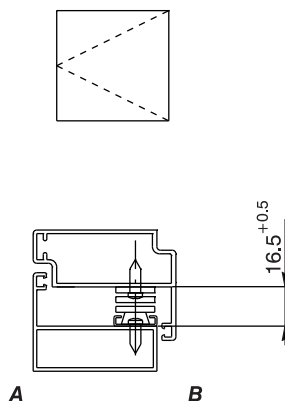

Unlocking element for cleaning the outside of the sash

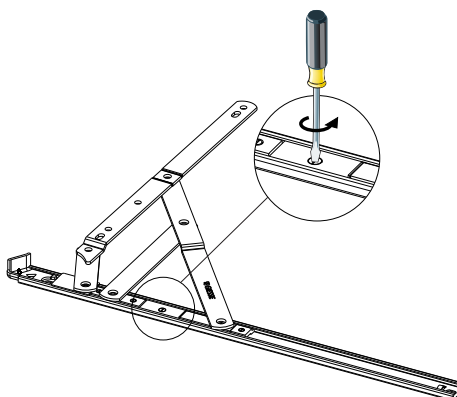

Item code	Description	Permitted type of opening	Egress	Loose rivet	Bag width	Sash - frame distance (mm)	Arm length (mm)	Maximum opening angle	Side Hung maximum height (mm)	Side Hung maximum width (mm)	Side Hung Maximum Weight (kg)	Side adjustment	Base Raw	Items per pack
08222	GS HD - 10" type C Plus	Side	NO	NO	~23	16,5+0,5	267	80°	1600	500	32	/	X	6
08223	GS HD - 12" type C Plus	Side	NO	NO	~23	16,5+0,5	313	84°	1600	600	38	/	X	6
08224	GS HD - 14" type C Plus	Side	NO	NO	~23	16,5+0,5	365	87°	1600	650	40	/	X	6
08225	GS HD - 16" type C Plus	Side	NO	NO	~23	16,5+0,5	414	87°	1800	750	42	/	X	6
08226	GS HD - 18" type C Plus	Side	NO	NO	~23	16,5+0,5	463	87°	1800	800	45	/	X	6

GS HD ARMS TYPE C PLUS SUPER



Functions

Pair of self-balancing arms (one right and one left) able to bear the weight of an outward opening side-hung window and hold it in the open position.

Online data sheet



Technical Features

"Type-C Plus Super" GS HD Super Arms are suitable for medium size/weight outward opening (side hung) casement windows (see table). Since the upper part of the arm is asymmetrical, within the pair of arms we will have a right and a left; this asymmetrical geometry of the arm improves the return and closing of the sash.

The window opening can also be frictioned by turning the grub screw on the slider.

These articles are equipped with a side adjustment element integrated in the arm. This feature allows micrometric adjustment of the correct positioning of the sash directly on site once installed.

Type-C Plus Super GS HD arms are tested by Giesse for up to life-time 30.000 cycles.

Applicability

"Type-C Plus Super" GS HD Super arms are applicable to profile systems with a gap (sash/frame distance) of 16.5 mm +/- 0.5 mm.



Ask to your sales rep for product availability.

Materials

AISI 304 stainless steel arm;
Slider in polyamide and 304 grade stainless steel
Zamak adjustment element

Side Hung (A: internal, B: external)

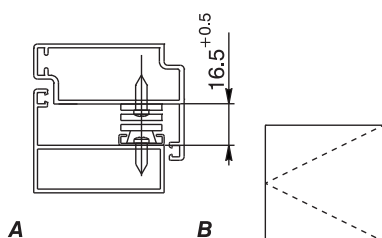

1: Side Hung arm. 2: width adjustment component. 3: frame

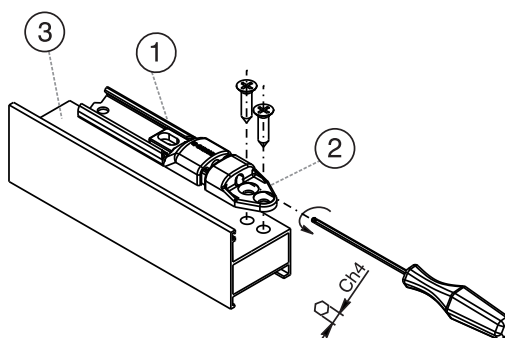

Side Hung

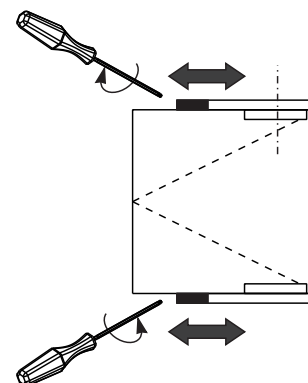

Item code	Description	Permitted type of opening	Bag width	Sash-frame distance (mm)	Arm length (mm)	Maximum opening angle	Maximum permissible height (mm)	Maximum permissible width (mm)	Maximum permissible weight (kg)	Side adjustment	Base Raw	Items per pack
08232	GS HD Super - 10" type C Plus	Side	~23	16,5+0,5	327,5	82	1600	500	32	integrated	X	6
08233	GS HD Super - 12" type C Plus	Side	~23	16,5+0,5	373,5	85	1600	600	38	integrated	X	6
08234	GS HD Super - 14" type C Plus	Side	~23	16,5+0,5	425,5	87	1600	650	40	integrated	X	6
08235	GS HD Super - 16" type C Plus	Side	~23	16,5+0,5	474,5	87	1600	750	42	integrated	X	6
08236	GS HD Super - 18" type C Plus	Side	~23	16,5+0,5	523,5	87	1600	800	45	integrated	X	6

ARMS FOR CURTAIN WALL-TOP HUNG-SIDE HUNG WINDOWS

GS HD ARMS TYPE P



Functions

Pair of self-balancing arms (one right and one left) able to bear the weight of a top hung window and hold it in the open position.

Online data sheet



Technical Features

Type-P GS HD arms are suitable for medium to large size/weight top-hung windows (see table). Since the upper part of the arm is asymmetrical, within the pair of arms we will have a right and a left; this asymmetrical geometry of the arm improves the return and closing phases. Type-P GS HD arms may be frictioned by way of the grub screw on the slider and, depending on the model, you can choose also the maximum sash opening angle (see table). To make operable fixtures with different dimensions and weights to those indicated in the table, please call the Giesse technical service. Type-P GS HD arms, depending on the version, provide micrometric height adjustment. If necessary, the P type arms can be applied with the I, L and Laser limitation arms; this is in order to limit the maximum opening of the sash. Type-P GS HD arms are tested by Giesse for up to life-time 30.000 cycles.

Applicability

Type-P GS HD arms are applicable to sets of profiles with a stack (sash/frame distance) of 16.5 - 17 mm.

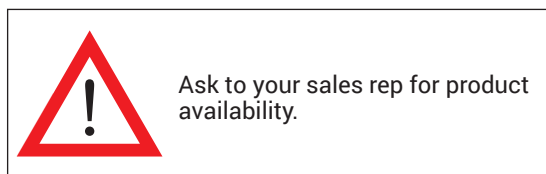

Ask to your sales rep for product availability.

Materials

AISI 304 stainless steel arm
Slider in polyamide and 304 grade stainless steel
Zamak height-adjustment device

1: Top hung arm. 2: height adjustment component.
3: frame.

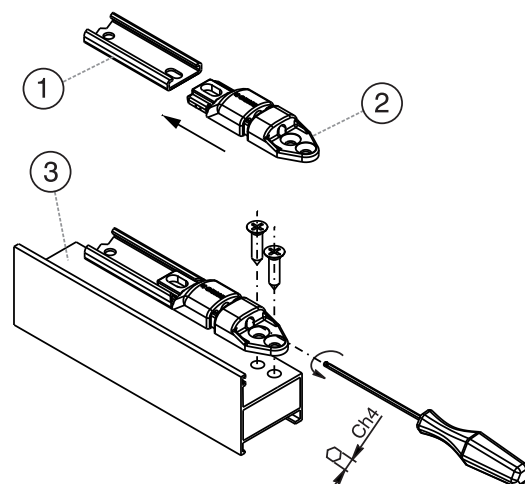

Top Hung (A: internal, B: external)

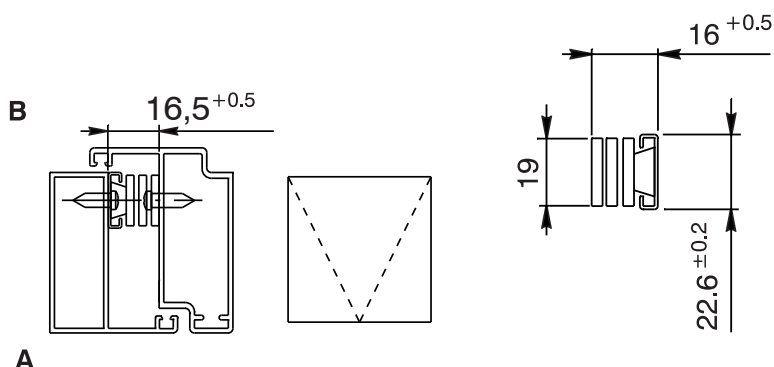

ARMS FOR CURTAIN WALL-TOP HUNG-SIDE HUNG WINDOWS

Item code	Description	PROFILE CROSS - SECTION	Permitted type of opening	Bag width (mm)	Arm thickness (mm)	Arm length (mm)	Opening angles	Top Hung maximum height (mm)	Top Hung maximum width (mm)	Top Hung Maximum Weight (kg)	Applicable height adjuster	Base Raw	Items per pack
08348	GS HD - 26-180" type P	-	Top	23	16,5+0,5	690	20°	2000	1500	155 - 180 limited to 7° by way of limitation arms	art. 02006K	X	6
08309	GS HD - 10" type P	C001-C002-C003-C004-C005-C006-C012	Top	-	Euro groove central gasket	259	50°	600	1500	25	-	X	6
08351	GS HD - 22" type P	C001-C002-C003-C004-C005-C006-C012	Top	-	Euro groove central gasket	567	20°/45°	1500	1700	100 (20°) - 80 (max 30°)	-	X	6
08352	GS HD - 28" type P	C001-C002-C003-C004-C005-C006-C012	Top	-	Euro groove central gasket	711	15°	2000	1700	100	-	X	6
08534N	GS HD - 10" type P	-	Top	23	16,5+0,5	261	35°	700	1200	50	art. 02006K	X	6
08535N	GS HD - 12" type P	-	Top	23	16,5+0,5	317	30°/35°	800	1200	60	art. 02006K	X	6
08536N	GS HD - 14" type P	-	Top	23	16,5+0,5	353	30°/35°	1000	1300	69,5	art. 02006K	X	6
08537N	GS HD - 16" type P	-	Top	23	16,5+0,5	414	30°/35°	1200	1400	88,5	art. 02006K	X	6
08538N	GS HD - 18" type P	-	Top	23	16,5+0,5	458	25°/30°	1400	1400	102	art. 02006K	X	6
08539N	GS HD - 20" type P	-	Top	23	16,5+0,5	511	25°/30°	1600	1500	135	art. 02006K	X	6
08540N	GS HD - 22" type P	-	Top	23	16,5+0,5	556	20°/25°	1700	1500	137	art. 02006K	X	6
08541N	GS HD - 24" type P	-	Top	23	16,5+0,5	602	20°/25°	1800	1500	139	art. 02006K	X	6
08542N	GS HD - 28" type P	-	Top	23	16,5+0,5	707	10°/15°/20°	2000	1500	155	art. 02006K	X	6

GS HD ARMS TYPE P SUPER



Functions

Pair of self-balancing arms (one right and one left) able to bear the weight of a top hung window and hold it in the open position.

Online data sheet



Technical Features

Type-P GS HD arms are suitable for medium to large size/weight top-hung windows (see table). Since the upper part of the arm is asymmetrical, within the pair of arms we will have a right and a left; this asymmetrical geometry of the arm improves the return and closing phases of the sash. Type-P GS HD arms may be frictioned by way of the grub screw on the slider and, depending on the model, you can choose also the maximum sash opening angle (see table). To make operable fixtures with different dimensions and weights to those indicated in the table, please call the Giesse technical service. Type-P GS HD arms, depending on the version, provide micrometric height adjustment with the sash already installed. If necessary, the P type arms can be applied with the I, L and Laser limitation arms; this is in order to limit the maximum opening of the sash. Type-P Super GS HD arms are tested by Giesse for up to life-time 30.000 cycles.

Applicability

Type-P GS HD arms are applicable to sets of profiles with a stack (sash/frame distance) of 16.5 - 17 mm.

Materials

AISI 304 stainless steel arm
Slider in polyamide and 304 grade stainless steel
Zamak height-adjustment device

1: Top hung arm. 2: height adjustment component. 3: frame.

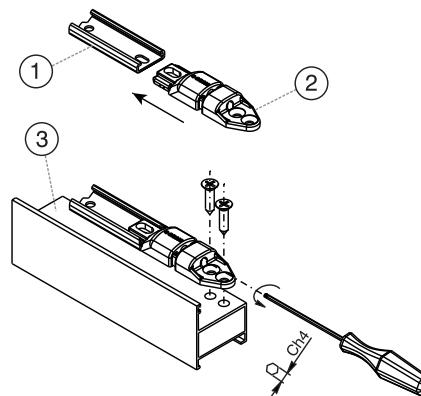

(a) self-tapping countersunk screws 4.8 mm, (b) shim for positioning arm.

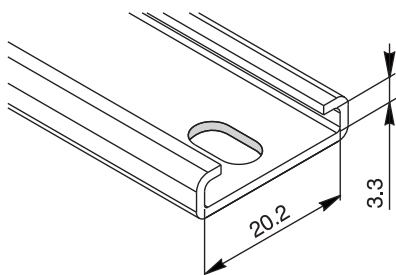
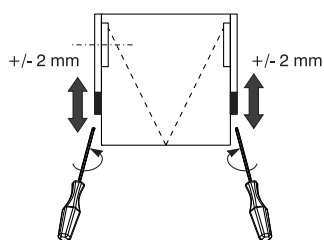
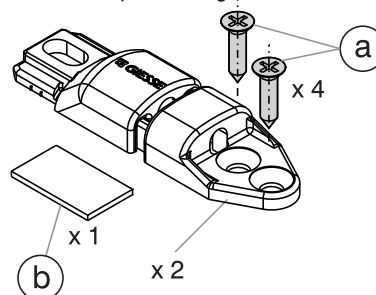

Item code	Description	Permitted type of opening	Bag width (mm)	Arm thickness (mm)	Arm length (mm)	Opening angles	Top Hung maximum height (mm)	Top Hung maximum width (mm)	Top Hung Maximum Weight (kg)	Height adjuster	Base Raw	Items per pack
08886	Super GS HD - 10" type P	Top	23	16,5+0,5	322	35°	700	1200	50	Integrated	X	6
08887	Super GS HD - 12" type P	Top	23	16,5+0,5	378	30°/35°	800	1200	60	Integrated	X	6
08888	Super GS HD - 14" type P	Top	23	16,5+0,5	414	30°/35°	1000	1300	69,5	Integrated	X	6
08889	Super GS HD - 16" type P	Top	23	16,5+0,5	475	30°/35°	1200	1400	88,5	Integrated	X	6
08890	Super GS HD - 18" type P	Top	23	16,5+0,5	519	25°/30°	1400	1400	102	Integrated	X	6
08891	Super GS HD - 20" type P	Top	23	16,5+0,5	572	25°/30°	1600	1500	135	Integrated	X	6
08892	Super GS HD - 22" type P	Top	23	16,5+0,5	617	20°/25°	1700	1500	137	Integrated	X	6
08893	Super GS HD - 24" type P	Top	23	16,5+0,5	663	20°/25°	1800	1500	139	Integrated	X	6
08894	Super GS HD - 28" type P	Top	23	16,5+0,5	768	10°/15°/20°	2000	1500	155	Integrated	X	6

GS HD ARMS TYPE TS



Functions

Pair of arms (RH/LH) for outward opening (side hung) or top hung aluminium windows.

Online data sheet



Technical Features

Type-TS GS HD arms are suitable for medium size/weight outward opening side hung or top hung windows (see table).

Since the upper part of the arm is asymmetrical, within the pair of arms we will have a right and a left; this asymmetrical geometry of the arm improves the return and closing of the sash.

The window opening can also be frictioned by turning the grub screw on the slider.

The Range of TS-type GS HD Arms is divided into two groups:

- a) applicable on systems with a stack of 16.5 mm
 - b) applicable on systems with a stack of 11.5 mm (European groove central gasket)
- (See table)

a) TS-type GS HD arms for systems with a stack of 16.5 mm require a sash/frame distance of 16.5 mm, market standard for curtain walls.

b) TS-type GS HD arms for European grooves (Euro groove central gasket) due to their special geometry position themselves in the channel 15/20 on the sash. Pre-assembled grub screws on the connecting bracket that fits in the sash allow quickly fixing the product at first. These arms mount to the frame (with 14/18 channel) with self-threading screws (not included). For solid, durable arm fixing on the frame you need to create a flat surface beneath it. For 14/18 or 13.5 / 16.8 frame channels, Giesse recommends using the filling shim (see the relevant family), to be assembled under each arm fixing hole/slot.

Type-TS GS HD arms are tested by Giesse for up to life-time 30.000 cycles.

Applicability

TS-type GS HD arms can be applied to systems with a stack of 16.5 or on European groove systems (Euro groove central gasket). See the figure and table.

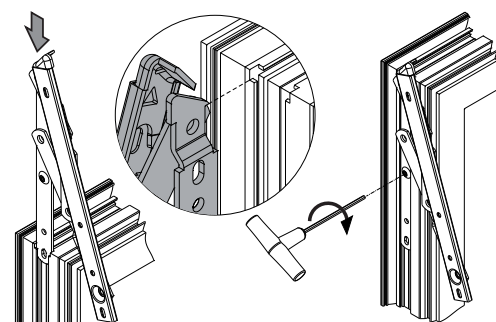

A: shim at the fixing screws by the window maker.

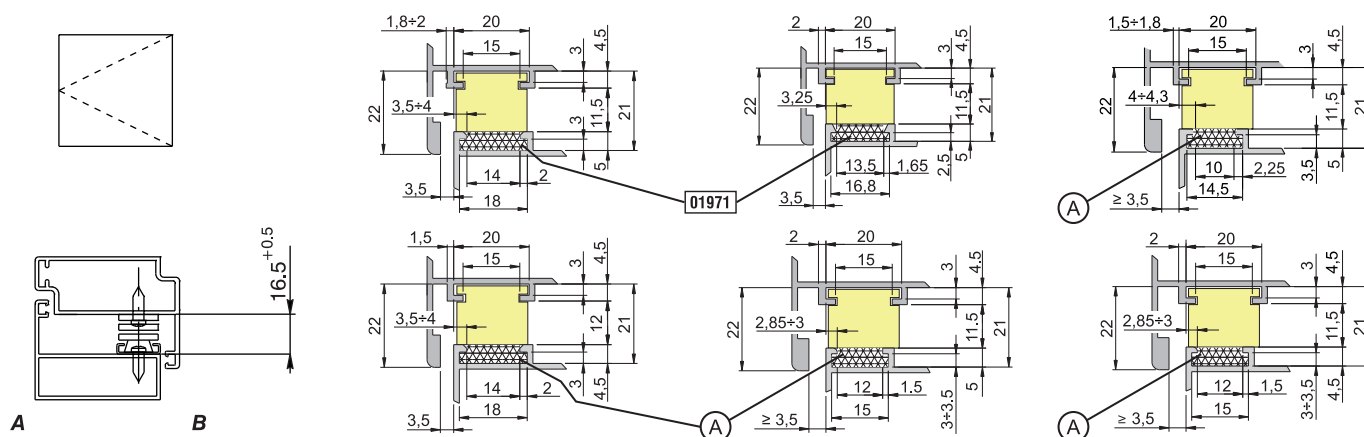

ARMS FOR CURTAIN WALL-TOP HUNG-SIDE HUNG WINDOWS

Art. 01971 set of shims

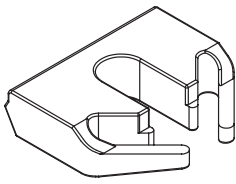

Inserting shim in channel

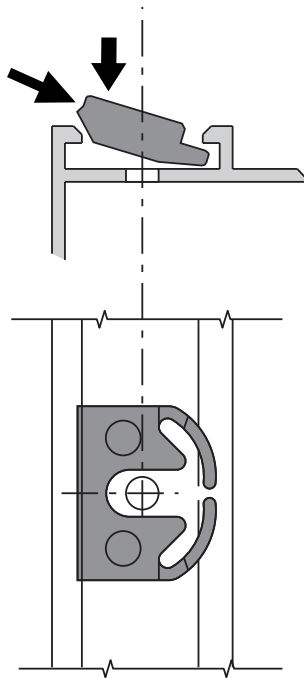

We recommend using limitation arms in the cases shown below

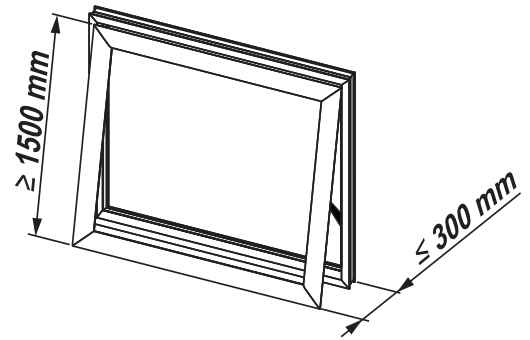

Item code	Description	PROFILE CROSS - SECTION	Bag width	Stack	Arm length (mm)	Loose rivet	TOP HUNG Opening angle	TOP HUNG Max-imum height (mm)	TOP HUNG Max-imum width (mm)	TOP HUNG Max-imum weight (kg)	SIDE HUNG Possible opening angle	SIDE HUNG Max-imum height (mm)	SIDE HUNG Max-imum width (mm)	SIDE HUNG Max-imum weight (kg)	Base Row	Items per pack
08341	GS HD - 10" type TS - L/R	-	22	16,5	259	Yes	50°	650	1500	50	50° / 84°	1500	660	35	X	6
08342	GS HD - 16" type TS	-	22	16,5	412	No	30° 50°	800	1500	100 55	50°/90° 30°	1600	760 700	42 60	X	6
08343	GS HD - 16" type TS - L/R	-	22	16,5	412	Yes	30° 50°	800	1500	100 55	30°/50°/90° 30°	1600	760 700	42 60	X	6
08349	GS HD - 10" type TS	C001-C002-C003-C004-C005-C006-C012	22	Euro groove central gasket	259	No	50°	650	1500	50	50/84	1500	660	35	X	6
08350	GS HD - 16" type TS	C001-C002-C003-C004-C005-C006-C012	22	Euro groove central gasket	412	No	30° 50°	800	1500	100 55	30° 50°/90°	1600	700	60 42	X	6

PROJECTING ARMS WITH HINGE



Functions

The LOTUS self-balanced set is a mechanism used for making top-hung windows.

Online data sheet



Technical Features

The LOTUS units are composed of a pair of steel hinges and a pair of aluminium arms.

The hinge is formed by a sliding system with constrained pins in order to prevent the sash from accidentally coming out under any circumstances. The hinge is set on the top of the sash and it positions itself on the frame, as it rests there. Both the hinge and the arm are secured with the self-threading screws supplied.

Materials

Oxidized aluminium arm rods
Hinge set, arm plates and fixing screws in zinc plated steel

Parts

4 Self-tapping screws 4.8x16
14 Self-tapping screws 4.2x13

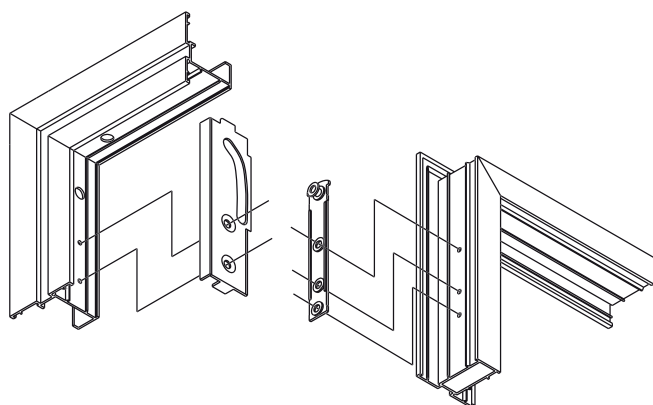
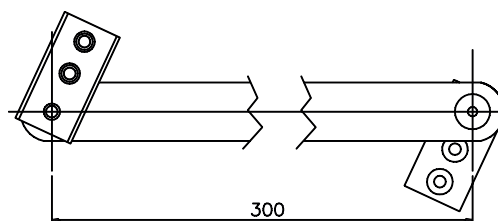
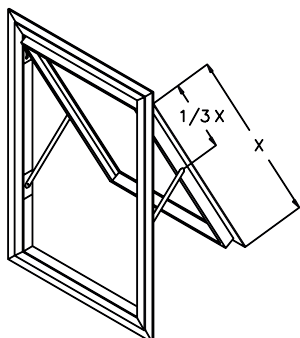

Machining on profile

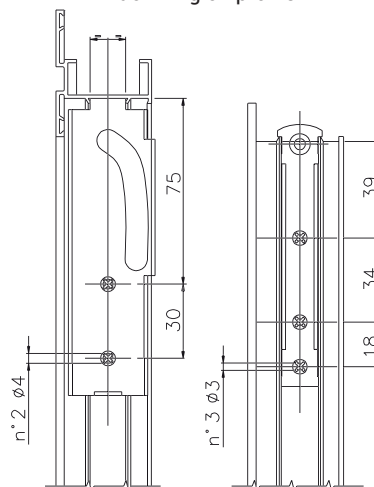

Item code	Description	Note	Base Raw	Anodised Elox	Painted	Trend/Gold Brass	Pieces per pack
01801	LOTUS SELF-BALANCED UNIT	L= 300 mm		X			10

SHIMS FOR PROJECTING ARMS



Functions

Accessories that allow quick installation and adjustment of the range of projecting arms.

Packaging

20 kits of 6 shims

Online data sheet



Code 01971

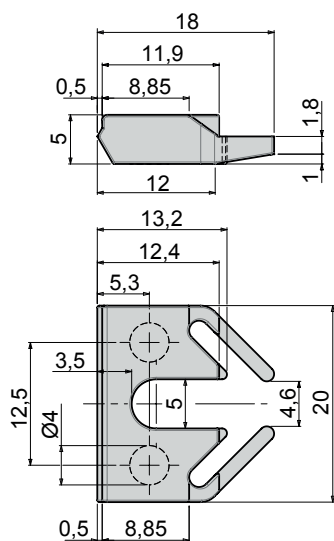

Code 01972

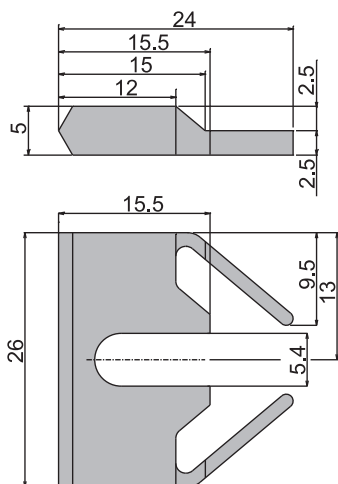

Code 01974

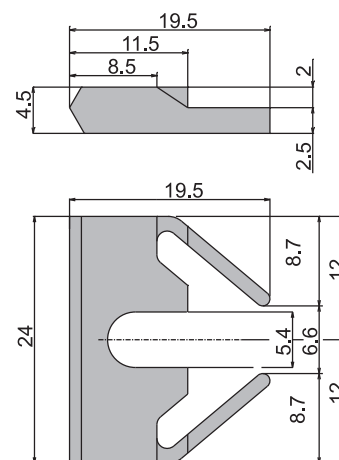

Example of application (A: sash, B: frame)

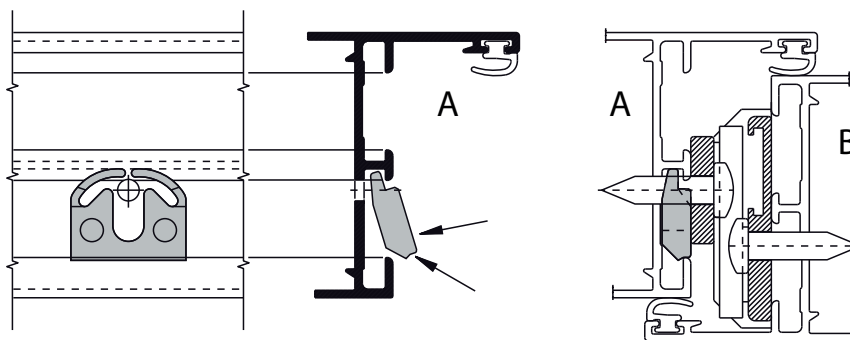

Item code	Description	PROFILE CROSS - SECTION	Notes	Base Raw	Anodised Elox	Painted	Trend/Gold Brass	Pieces per pack
01971	Polyamide filling shim	C001-C007-C016	for 14/18 channel (frame)	X				20
01972	Polyamide filling shim	C008	-	X				20
01974	Polyamide filling shim	C001-C003-C009-C010	for 15/20 channel (sash)	X				20

TOP HUNG ARMS ADJUSTMENT DEVICES



Functions

Pair of height adjustment devices which, if applied to correctly prepared GS HD arms make it possible to adjust a top hung window in height.

Online data sheet



Technical Features

The height-adjustment device has an adjustment range of +/- 2 mm. Art. 02006K is compatible with the GS HD type P range of arms.

Materials

Silver Plus GS Zamak housing
Stainless steel adjustment and fixing screws

Code 02006

Dimensions, art. 02006

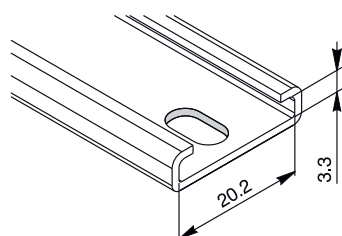
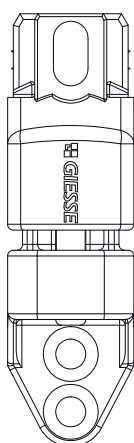

(a) self-tapping countersunk screws 4.8 mm, (b) shim for positioning arm.

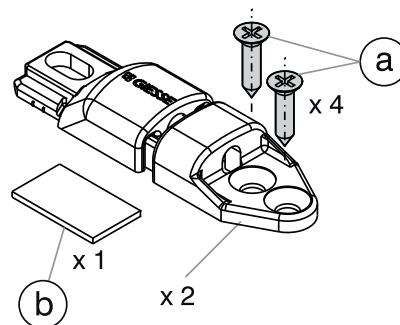

1: Top Hung arm; 2: height adjustment component; 3: frame

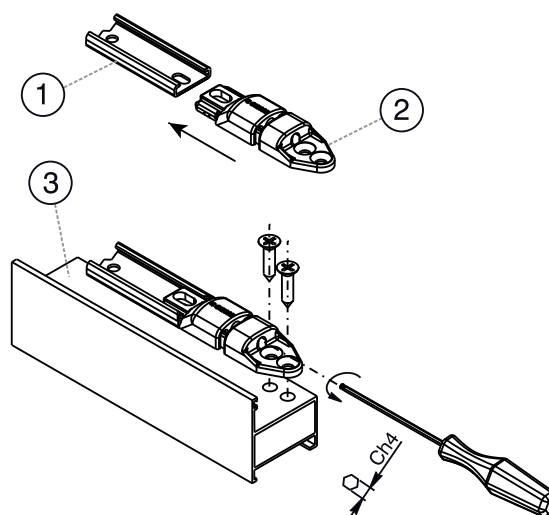

Item code	Description	Applicable on	Base Raw	Anodised Elox	Painted	Trend/Gold Brass	Pieces per pack
02006K	Arm height adjustment element GS HD - CP (22/23)	GS HD arms Type P	X				12

ARMS FOR CURTAIN WALL-TOP HUNG-SIDE HUNG WINDOWS

LASER ARMS

Functions

Pair of telescopic arms (one right and one left) able to limit the opening of a top hung window in different positions.

Online data sheet



Technical Features

These limitation arms are suitable for top-hung windows. The Arm is telescopic with 5 clicks (except for art. 01951 that only has 1) that give 5 different window opening positions. The window is closed by pushing it in the maximum opening position. The use of these items is intended on top hung windows as they cannot be released and, therefore, with side hung windows, the sash would not be openable to 90° for cleaning. On request it is possible to have Laser Arms with a lower number of catches (with the same length) and for this we invite you to contact our Giesse Customer Service. For the details, please see also the table below.

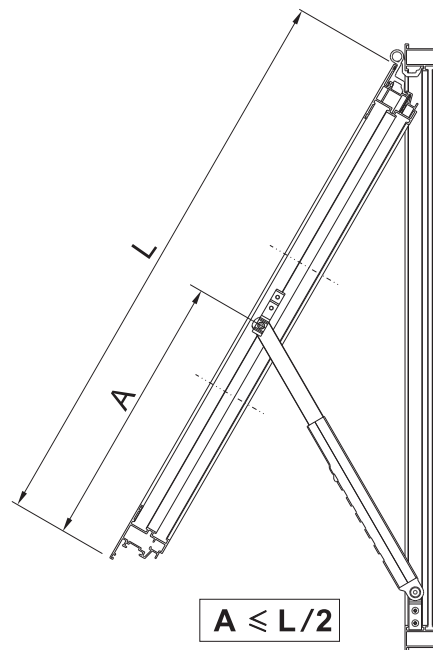

Art. 01950

Art. 01951

Art. 01959

Art. 01956

Art. 01960

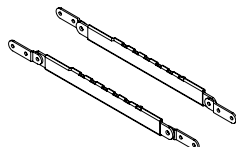
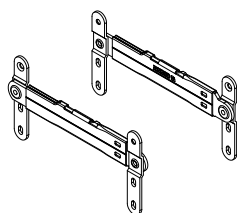
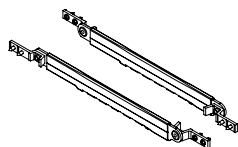

Part art. 01950, 01952, 01954, 01955

Part art. 01956

Part art. 01960, 01961



ARMS FOR CURTAIN WALL-TOP HUNG-SIDE HUNG WINDOWS

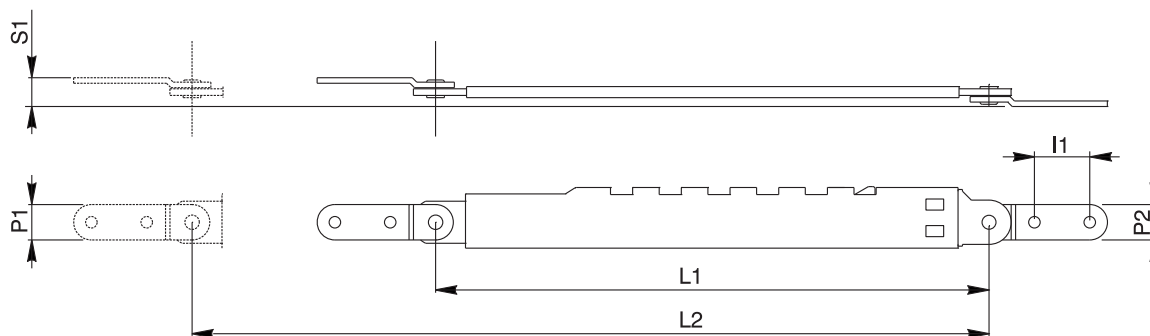

Item code	Description	Permitted type of opening	Applicable in combination with	PROFILE CROSS-SECTION	N positions	Material	Type of Fixing	P1	P2	L1	L2	I1	S1	Base Raw	Items per pack
01950	LASER ARM	Top	hinges	see Where Used	5	AISI 304	Self-threading	14,8	11,8	250	360	15	28	X	10
01951	LASER ARM	Top	universal	see Where Used	1	AISI 316	Self-threading	16	16	155	186	20,5	13,5	X	6
01952	LASER ARM	Top	hinges	see Where Used	5	AISI 304	Self-threading	15	15	250	360	15	34	X	10
01954	LASER ARM	Top	hinges	see Where Used	5	AISI 304	Self-threading	13,4	13,4	250	360	15	23	X	10
01955	LASER ARM	Top	hinges	see Where Used	5	Galvanized steel	Self-threading	13,4	13,4	250	360	15	23	X	10
01956	LASER ARM	Top	hinges	C007	5	AISI 304	Contrast grub-screws	-	-	250	360	-	24	X	10
01959	LASER ARM - Q	Top	universal	Without channels	5	AISI 304	Self-threading	16	16	250	360	23	13	X	6
01960	LASER ARM	Top	universal	Without channels	5	AISI 304	Self-threading	16	16	250	360	20	16,5	X	10
01961	LASER ARM	Top	universal	Without channels	5	Galvanized steel	Self-threading	16	16	250	360	20	16,5	X	10

LIMITATION ARMS TYPE I



Functions

Pair of reversible limitation arms able to limit the opening of a top hung window.

Online data sheet



Technical Features

Type-I limitation arms are suitable for top-hung windows. These arms work in combination with GS HD arms type A and P and can be frictioned by turning the knob on the slider. Giesse has tested these limitation arms and obtained a pull resistance greater than 200 kg/pair.

Note: You are advised to use these products only with top hung windows as they are fixed to the profile with self-threading screws and cannot be released and, therefore, with side hung windows, the sash would not be openable to 90° for cleaning.

Applicability

Type-I limitation arms are applicable to sets of profiles with a stack (sash/frame distance) from 15 to 18 mm.

Materials

AISI 304 stainless steel limitation arm
Slider in polyamide and brass

Packaging

6 pairs per pack

Top Hung (A: internal, B: external)

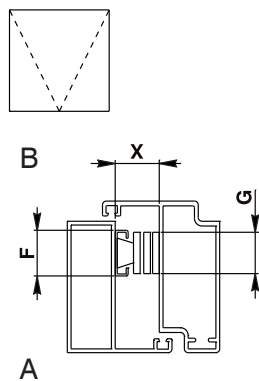
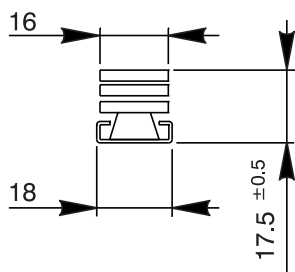

X = 15 mm ÷ 18 mm
F = 18 mm
G = 16 mm

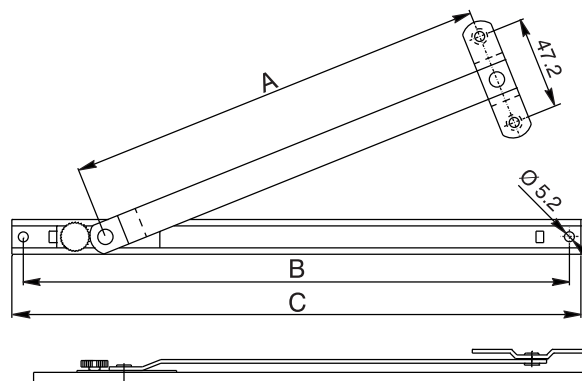

Item code	Description	Permitted type of opening	Bag width	Applicable in combination with Top Hung arms	A	B	C	Base Raw	Items per pack
08123	Pair of limitation arms - 8,5" type I	Top	18	Type A - Type P	140	205	217	X	6
08124	Pair of limitation arms - 10,5" type I	Top	18	Type A - Type P	191	256	268	X	6
08177	Pair of limitation arms - 12" type I	Top	18	Type A - Type P	221	286	298	X	6
08178	Pair of limitation arms - 14" type I	Top	18	Type A - Type P	267	332	244	X	6
08179	Pair of limitation arms - 16" type I	Top	18	Type A - Type P	318	388	400	X	6
08183	Pair of limitation arms - 18" type I	Top	18	Type A - Type P	365	435	447	X	6

LIMITATION ARMS TYPE L



Functions

Pair of telescopic arms (one right and one left) able to limit the opening of a top hung window in one position.

Online data sheet



Technical Features

Type-L limitation arms are suitable for top-hung windows. These arms work in combination with GS HD arms type A and P.

Type-L limitation arms have an opening notch; they can be locked in this position by means of a lever, to prevent the sash from closing. In this way the sash will remain locked until the user puts the lever back to the open position. Giesse has tested these limitation arms and obtained a pull resistance greater than 200 kg/pair.

Note: You are advised to use these products only with top hung windows as they are fixed to the profile with self-threading screws and cannot be released and, therefore, with side hung windows, the sash would not be openable to 90° for cleaning.

Applicability

Type-L limitation arms are applicable to sets of profiles with a stack (sash/frame distance) of from 15 to 17.5 mm.

Materials

AISI 304 stainless steel limitation arm

Packaging

6 pairs per pack

Top Hung (A: internal, B: external)

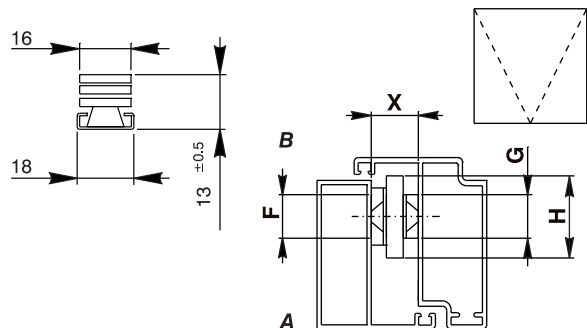

X= 15mm ÷ 17.5mm
F= 19 mm
G= 14.8 mm
H= 29 mm

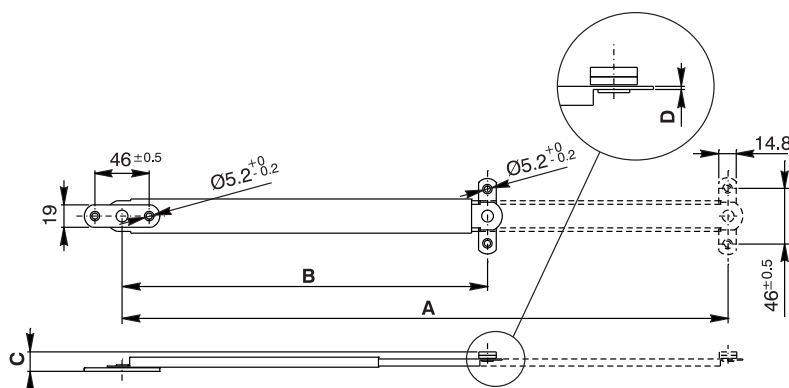

Item code	Description	Permitted type of opening	Applicable in combination with Top Hung arms	no. of notches	A	B	C	D	Base Raw	Items per pack
08184	Pair of limitation arms (RH/LH) - 8" type L	Top	Type A - Type P	1	205	155	16,5	1,2	X	6
08185	Pair of limitation arms (RH/LH) - 10" type L	Top	Type A - Type P	1	255	180	16,5	1,2	X	6
08186	Pair of limitation arms (RH/LH) - 12" type L	Top	Type A - Type P	1	305	205	16,5	1,2	X	6
08187	Pair of limitation arms (RH/LH) - 14" type L	Top	Type A - Type P	1	355	230	16,5	1,2	X	6
08188	Pair of limitation arms (RH/LH) - 16" type L	Top	Type A - Type P	1	406	257	16,5	1,2	X	6
08189	Pair of limitation arms (RH/LH) - 20" type L	Top	Type A - Type P	1	515	310	16,5	1,2	X	6

ARMS FOR CURTAIN WALL-TOP HUNG-SIDE HUNG WINDOWS

LIMITATION ARMS TYPE N

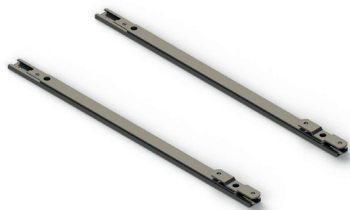

Functions

Pair of reversible limitation arms able to limit the opening of a top hung window.

Online data sheet



Technical Features

"Type-N" limitation arms are suitable for top-hung windows. These arms work in combination with GS HD arms type M and can be frictioned by turning the grub screw on the slider. Giesse has tested these limitation arms and obtained a pull resistance greater than 200 kg/pair. The use of these items is intended only on top hung windows as they are fixed to the profile with self-threading screws and cannot be released and, therefore, with side hung windows, the sash would not be openable to 90° for cleaning.

Applicability

Type-N limitation arms are applicable to sets of profiles with a stack (sash/frame distance) from 15 to 18 mm.

Materials

AISI 304 stainless steel limitation arm
Slider in polyamide and brass.

Packaging

6 pairs per pack

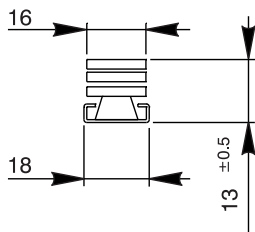

Top Hung (A: internal, B: external)

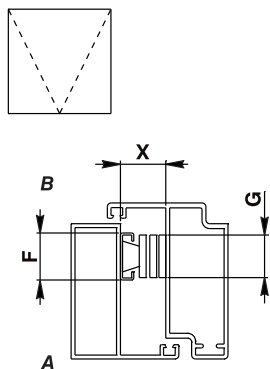

X= 13 mm ÷ 16mm
F= 18 mm
G= 16 mm

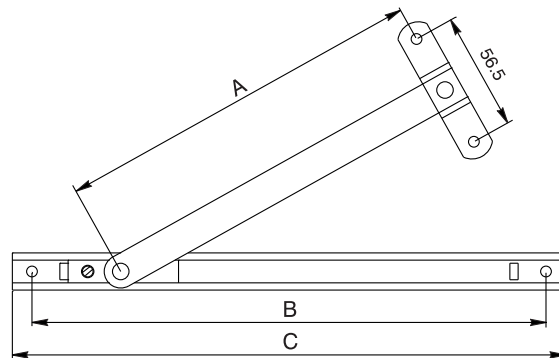

Item code	Description	Permitted type of opening	Bag width	Applicable in combination with Top Hung arms	A	B	C	Base Raw	Items per pack
08199	Pair of limitation arms - 10,5" type N	Top	23	Type M	180	249	268	X	6
08200	Pair of limitation arms - 16" type N	Top	23	Type M	314	381	400	X	6

FRIZ ARMS FOR OUTWARD OPENING CASEMENT



Functions

Arm limiting sash opening on Top and Side Hung casement

Online data sheet



Technical Features

The Friz Arms are applicable on both top and side hung outward opening casement systems with a stack (sash frame distance) of 16.5 mm.

On Top Hung casements we recommend installing an arm on each upright (2 pieces).

You can friction the arm (and then decide on the force required for opening and closing the sash) by turning the screw on the slider.

It is possible to unhook the arm with the aid of the steel mechanism. This enables opening the sash completely for cleaning the glass.

The arm is supplied with a limit stop plate that defines the maximum desired opening of the sash.

Materials

Extruded aluminium arm

Polyamide frictioning slider

Stainless steel frictioning screw and fixing screws

Frame coupling plate in stainless steel

Positioning on top hung casement

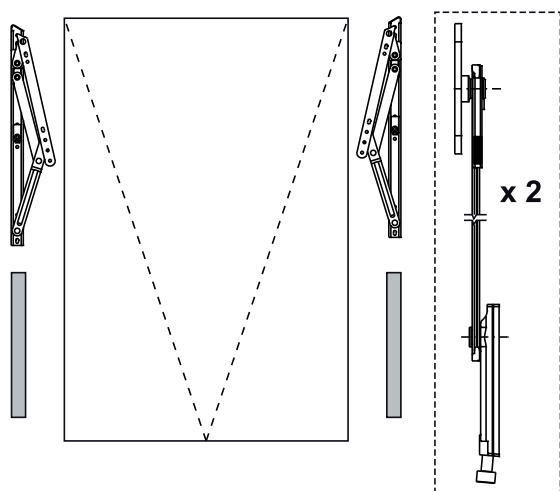

Positioning on side hung casement

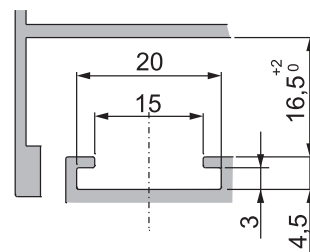
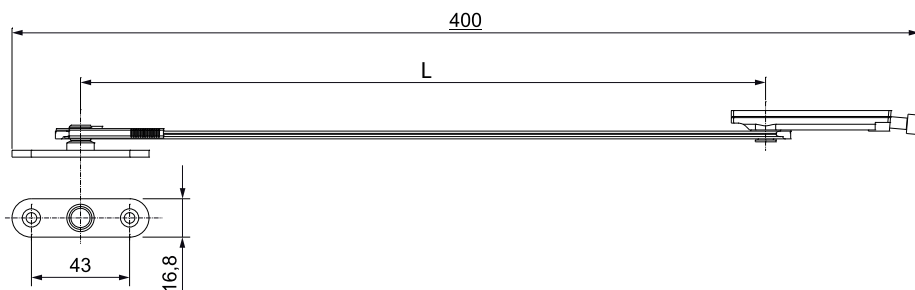
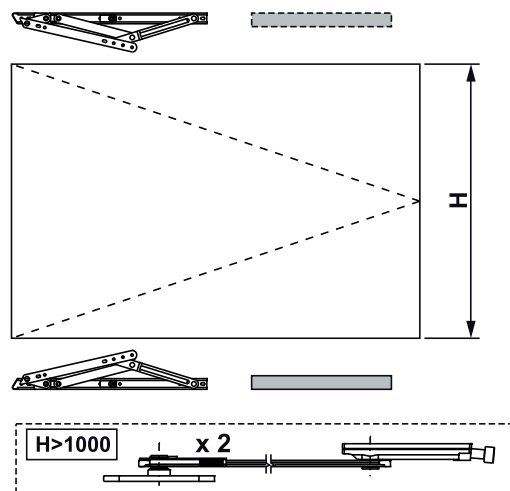

Item code	Description	Permitted type of opening	Applicable in combination with Top Hung arms	Rod length (L)	Unhookable	Frictionable	Base Raw	Items per pack
02036	Friz Stay Limitation Arm	Top - Side	Type A - Type P - Type C	300 mm	YES	YES	X	10
02037	Friz Stay Limitation Arm	Top - Side	Type A - Type P - Type C	140 mm	YES	YES	X	10

ARMS FOR CURTAIN WALL-TOP HUNG-SIDE HUNG WINDOWS

PARALLEL ARMS



Functions

The reversible parallel arms enable opening the sash of a curtain wall or a projecting wall in parallel with the fixed part of the curtain wall.

Online data sheet



Technical Features

These arms enable opening the sash outwards, parallel to the frame. Generally the intended use of these arms is for an operable element in a curtain wall. The added value of this type of solution is its stylishness because the curtain wall no longer "breaks" the reflection of the light but maintains uniformity between the surface of the operable part and the fixed part. The parallel arms are reversible arms packaged in pairs, that is 2 pcs in the pair are identical and equally applicable on either side of the casement. They are available in single and double cross versions for the heavier casements of considerable dimensions.

It is possible to combine single-cross arms with double-cross arms when the arm thickness is the same.

For sashes weighing > 60 kg or sized > 1250 x 1250 mm it is required to use a sash opening and closing system that uses motors.

The especially sturdy, durable arm is made entirely of corrosion proof 304 stainless steel.

The window opening can also be frictioned by turning the screws on the sliders.

Materials

AISI 304 stainless steel arm
Slider in black polyamide

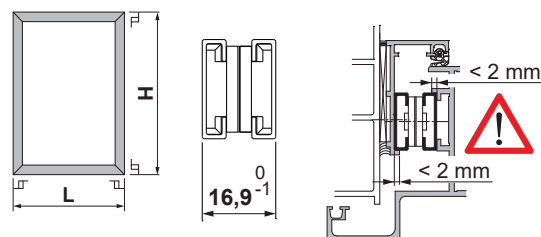

Weight/automatic or manual fastening mechanism Table

P	kg	Diagram 1	Diagram 2
110 < P < 200			x4
60 < P < 110			x2
P < 60 L < 1250 mm H < 1250 mm			
		x2	x2

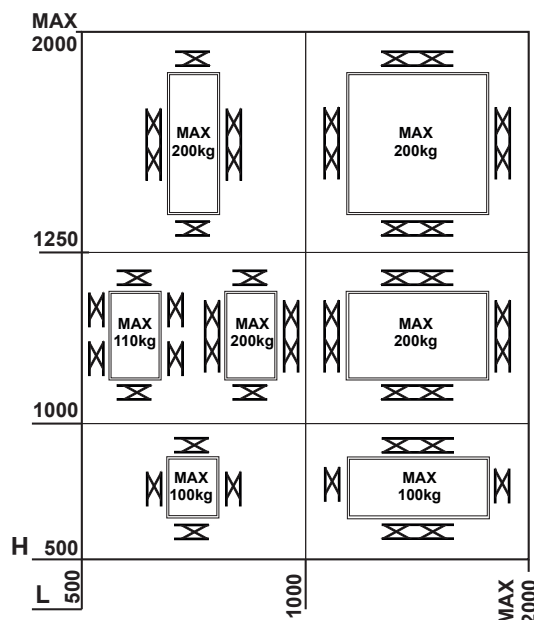

Item code	Description	Permitted type of opening	Bag width (mm)	Arm thickness (mm)	Arm length (mm)	Maximum Opening (mm)	Maximum height (mm)	Maximum width (mm)	Maximum Weight (kg)	Base Raw	Anodised Elox	Painted	Trend/Gold Brass	Pieces per pack
0199002	Parallel Arm 16.9	parallel	22	16.9 +0/-1	470	180	1000	1000	100	X				10
0199102	Double Parallel Arm 16.9	parallel	22	16.9 +0/-1	940	180	2000	2000	200	X				5

G-TYPE PARALLEL ARMS



Functions

Reversible parallel arms allow the sash of a curtain wall or external opening to be opened in parallel.

Online data sheet



Technical Features

Parallel arms are packaged in pairs of a right-hand and a left-hand one. These arms enable opening the sash outwards, parallel to the frame. In general, the intended use of this arm is for an opening within a curtain wall. The added value of this type of opening is aesthetic, as the curtain wall no longer "breaks" light reflection but maintains uniformity between the surface of the opening and the fixed part.

The particularly strong and durable arms are made of corrosion proof 304 stainless steel.

The products are suitable for application on profile series with a sash-frame distance of 21 mm.

It is possible to obtain a more accurate sash setting and to adjust the compression on the gaskets (± 1 mm) by turning the pins with hexagonal recess located on the arm.

The arms have 2 maximum opening positions (position A and B).

Position A) or B) is selected by fixing the stop plate inside the arm in one of the two holes.

The maximum opening (A or B) selected on the arm can determine a different maximum load capacity (see table).

Depending on the size and weight of the sash, it is possible to combine single cross or double cross arms.

Materials

AISI 304 stainless steel arm

01969001 - 01976001
01977001 - 01978001 - 01979001

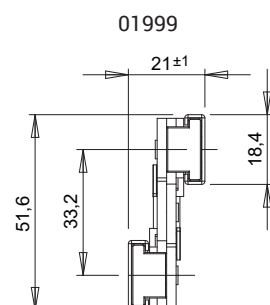
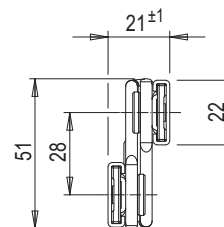

Compression adjustment

Opening adjustment

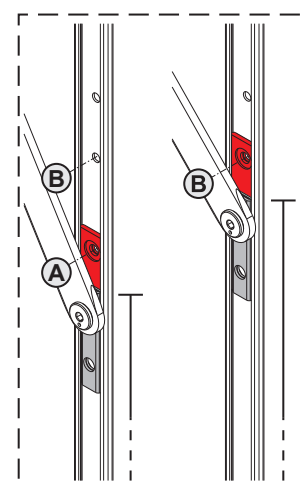
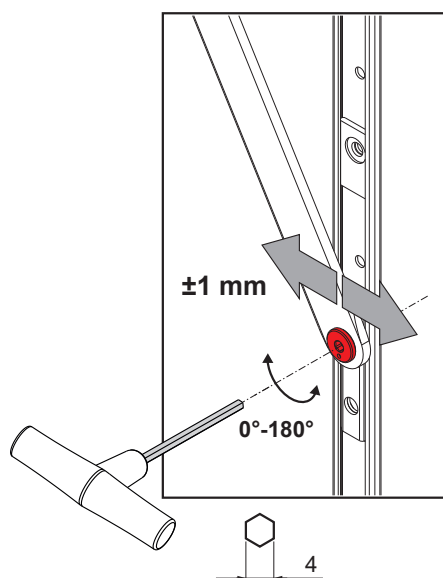
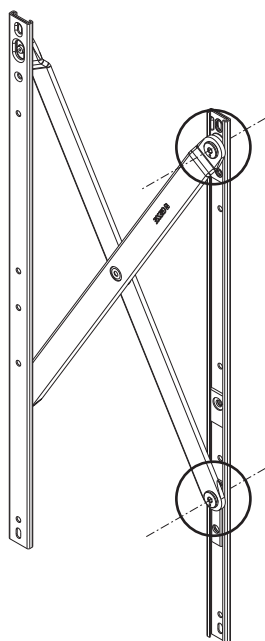

ARMS FOR CURTAIN WALL-TOP HUNG-SIDE HUNG WINDOWS

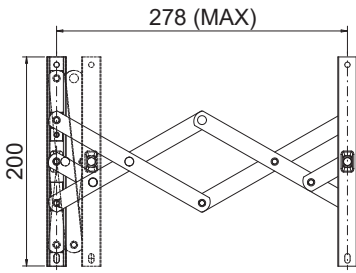

01999

SASH SIDE

FRAME SIDE

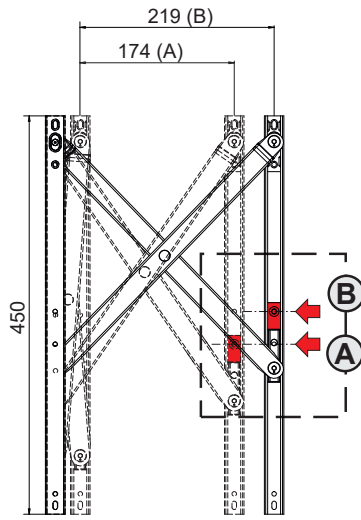

01969001

SASH SIDE

FRAME SIDE

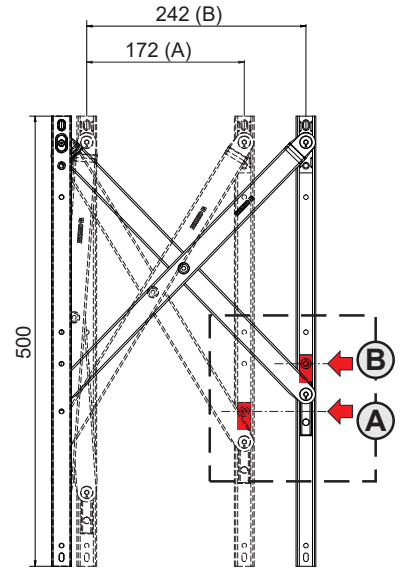

01976001

SASH SIDE

FRAME SIDE

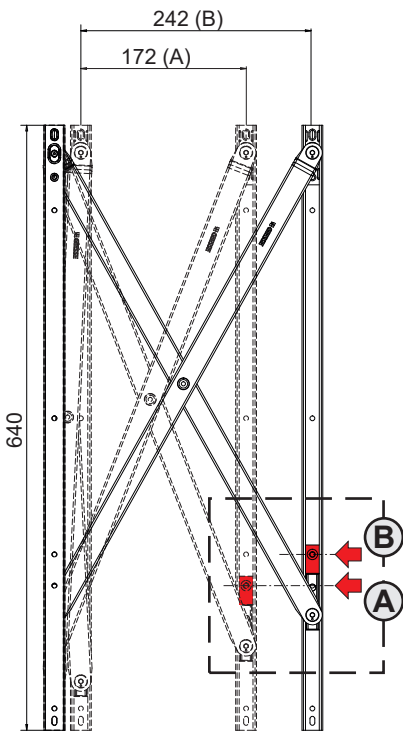

01977001

SASH SIDE

FRAME SIDE

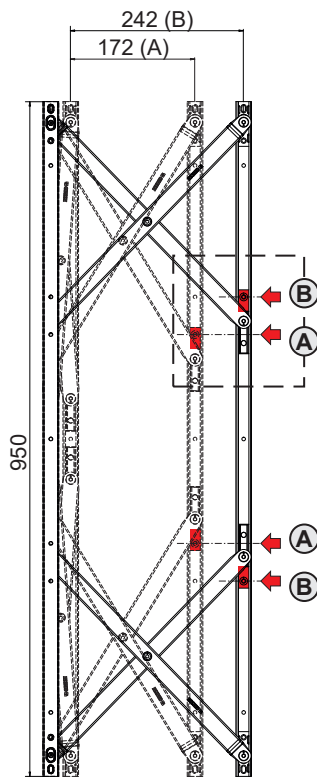

01978001

SASH SIDE

FRAME SIDE

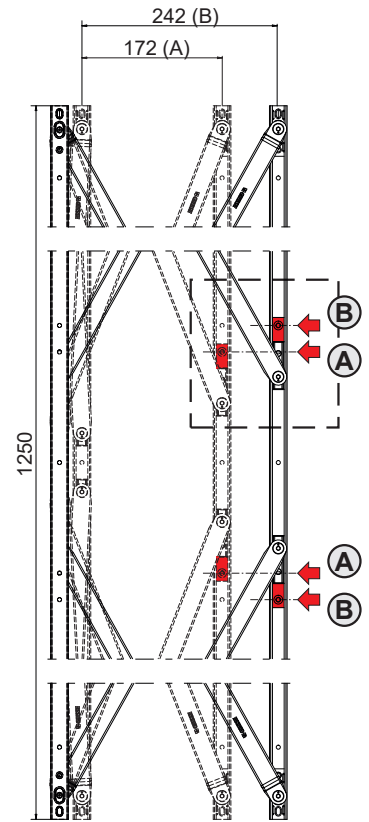

01979001

SASH SIDE

FRAME SIDE

ARMS FOR CURTAIN WALL-TOP HUNG-SIDE HUNG WINDOWS

Configuration diagrams

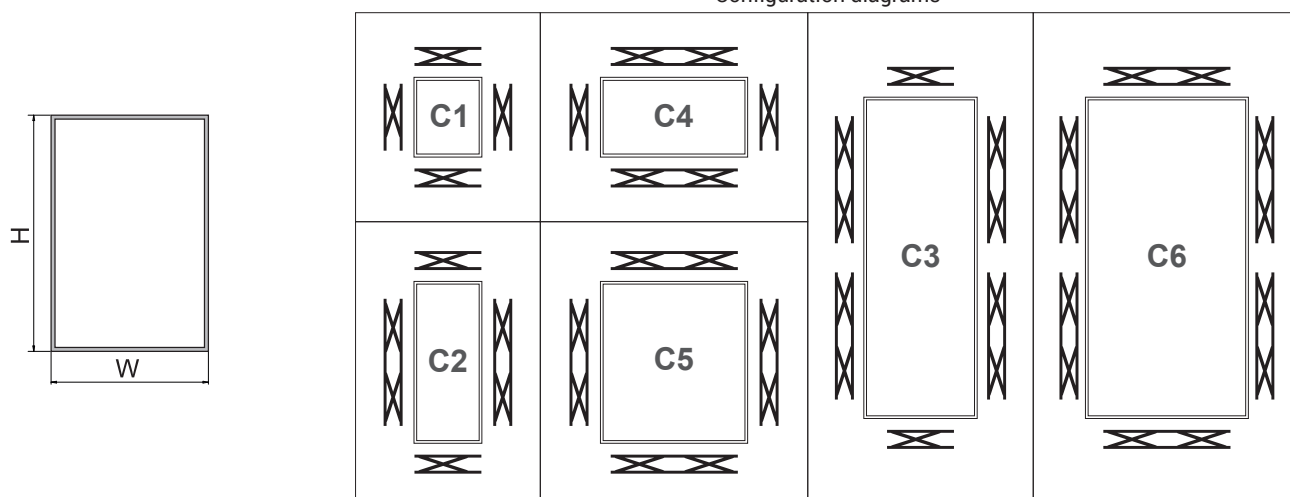

Configurations, dimensions and load capacities

Configura-tion	Description	Manufac-tured with	Min H	Max H	Min W	Max W	Max. weight (A) [kg]	Max. weight (B) [kg]	Manual Opening	Automatic Opening
C1	2 pair of single arms	01999 + 01969001	600	1000	300	600	55	55	yes	yes
C1	2 pair of single arms	01969001	600	1000	600	1000	55	55	yes	yes
C1	2 pair of single arms	01977001	800	1200	800	1200	75	75	yes	yes
C2	1 pair of single arms + 1 pair of double arms	01999 + 01978001	1100	1500	300	650	200	170	yes	yes
C2	1 pair of single arms + 1 pair of double arms	01977001 + 01979001	1400	1800	800	1200	200	200	no	yes
C003	1 pair of single arms + 2 pairs of double arms	01999 + 01978001 (x2)	2200	3000	300	650	200	170	yes	yes
C003	1 pair of single arms + 2 pairs of double arms	01977001 + 01979001 (x2)	2800	3600	800	1200	200	200	no	yes
C4	1 pair of single arms + 1 pair of double arms	01977001 + 01979001	800	1200	1400	2000	75	75	yes	yes
C5	2 pairs of double arms	01978001 (x2)	1100	1500	1100	1500	200	170	no	yes
C5	2 pairs of double arms	01979001 (x2)	1400	1800	1400	1800	200	200	no	yes
C6	3 pairs of double arms	01978001 (x3)	2200	3000	1100	1700	200	170	no	yes
C6	3 pairs of double arms	01979001 (x2) + 01978001	2800	3600	1100	1700	200	200	no	yes

Item code	Description	Type of opening	Bag width (mm)	Arm thickness (mm)	Arm length (mm)	Maximum Opening A (mm)	Maximum Opening B (mm)	Compression adjustment (mm)	Base Raw	Anodised Elox	Painted	Trend/Gold Brass	Pieces per pack
01999	SINGLE PARALLEL ARM 8"-TYPE G - CP	parallel	18,4	20,2 ±1	200	278	-	-	X				4
01969001	SINGLE PARALLEL ARM 18"-TYPE G - CP	parallel	22	21 ±1	450	174	219	±1	X				4
01977001	SINGLE PARALLEL ARM 25"-TYPE G - CP	parallel	22	21 ±1	640	172	242	±1	X				4
01978001	DOUBLE PARALLEL ARM 39"-TYPE G - CP	parallel	22	21 ±1	950	172	242	±1	X				4
01979001	DOUBLE PARALLEL ARM 50"-TYPE G - CP	parallel	22	21 ±1	1250	172	242	±1	X				4

PROJECTING CLOSING AND LIMITATION ARMS

Functions

The Ombu Arm closes and locks open a top-hung window.

Online data sheet



Technical Features

The Ombu Arm is a sturdy, easy to install product that ensures excellent closing for top-hung windows.

With the window closed the Ombu Arm folds back 90° horizontally so that the space it takes up in the room is practically none.

There are 2 different Ombu arm lengths: (see table)

The Ombu Arm can be installed on stepped profiles from 0mm (flush) up to 20 mm, thanks to the adjustment of the plate for fixing to the frame.

The arm can be used on casements with an top-hung opening, in combination with hinges or self-balancing arms, depending both on the weight and size and on the type of use and environment in which it will be moved.

Materials

Steel arm

Black polyamide lever

Zamak frame and sash fixing components

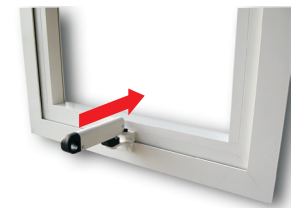
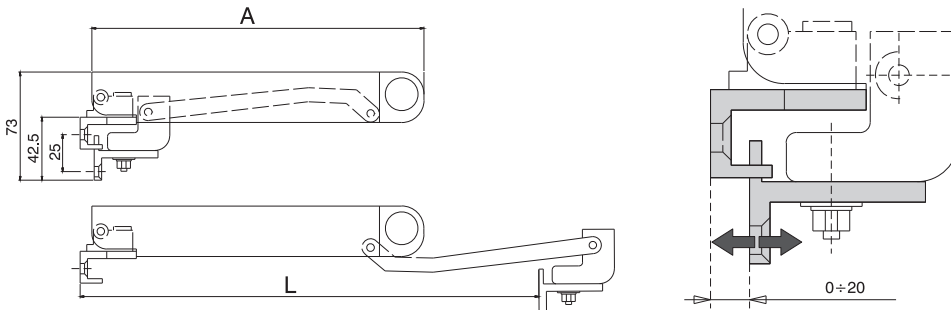
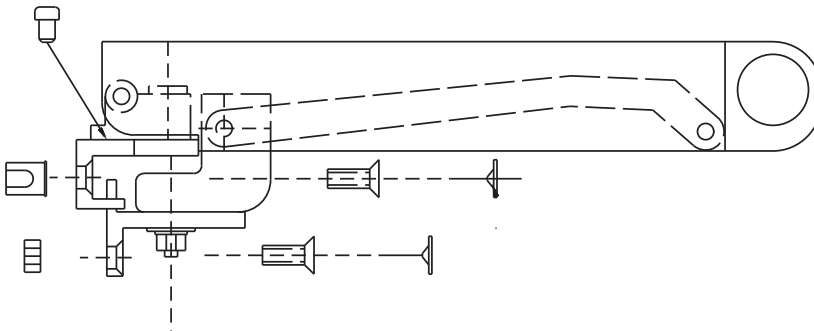

Item code	Description	Length (A)	Opening (L)	Minimum sash width	Base Raw	Anodised Elox	Painted	Trend/Gold Brass	Pieces per pack
00889N	OMBU Arm For Awning	160	172	> = 320			X		10
00890N	OMBU Arm For Awning	224	300	> = 450			X		10

ULK KIT

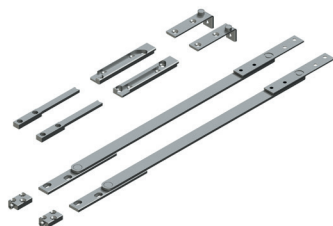

Functions

Set of components to produce top-hung or bottom-hung windows.

Online data sheet



Technical Features

The Ulk kit has been created to meet the need for Top-Hung and Bottom-Hung openings which have considerable weight and size.

Thanks to the Ulk kit, windows can be manufactured with sashes weighing up to 250 kg with Top-Hung opening and up to 300 kg with external Bottom-Hung opening (smoke vents).

The Ulk kit has been specifically designed for 17 mm door/frame stack systems, which is the sash/frame distance of all the main systems used for curtain walls.

The Ulk kit is composed of several components, all made of stainless steel: a pair of hinges, a pair of arms and a pair of adjustment devices for adjusting the sash height when Ulk is applied on Top-Hung windows.

The Ulk kit is ideal for large openings with sashes of considerable weight, for this reason it is advisable to use suitable automations for opening and closing the sash.

Top-Hung windows can be manually operated if the sash weighs less than 100 kg, but always in combination with limitation arms.

In case of Bottom-Hung openings (smoke vents) the opening must always be automated.

The maximum permitted sash opening in both Top-Hung and Bottom-Hung windows is 300 mm.

Materials

AISI 304 stainless steel

Parts

- 1 pair of hinges (Right - Left)
- 1 pair of arms
- 1 height adjustment device
- 2 stop elements



OUTWARD TOP-HUNG		OUTWARD BOTTOM-HUNG	
Manual mode (*)	Load capacity ≤ 100 kg	Manual mode	Not allowed
Motorized	Load capacity ≤ 250 kg	Motorized	Load capacity ≤ 300 kg
H [mm]	1500 ÷ 3500	H [mm]	1500 ÷ 4500
W [mm]	≤ 2000	W [mm]	≤ 2000

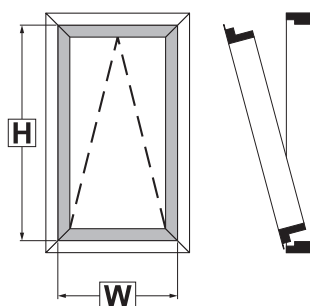
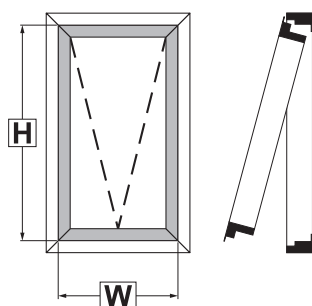

(*) With Manual Opening it is necessary to use opening limitation arms.

For the correct choice of opening limitation arms contact Giesse Technical Service.

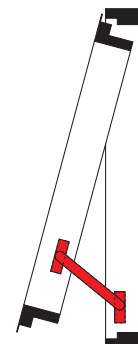

ARMS FOR CURTAIN WALL-TOP HUNG-SIDE HUNG WINDOWS

OUTWARD TOP-HUNG

OUTWARD BOTTOM-HUNG

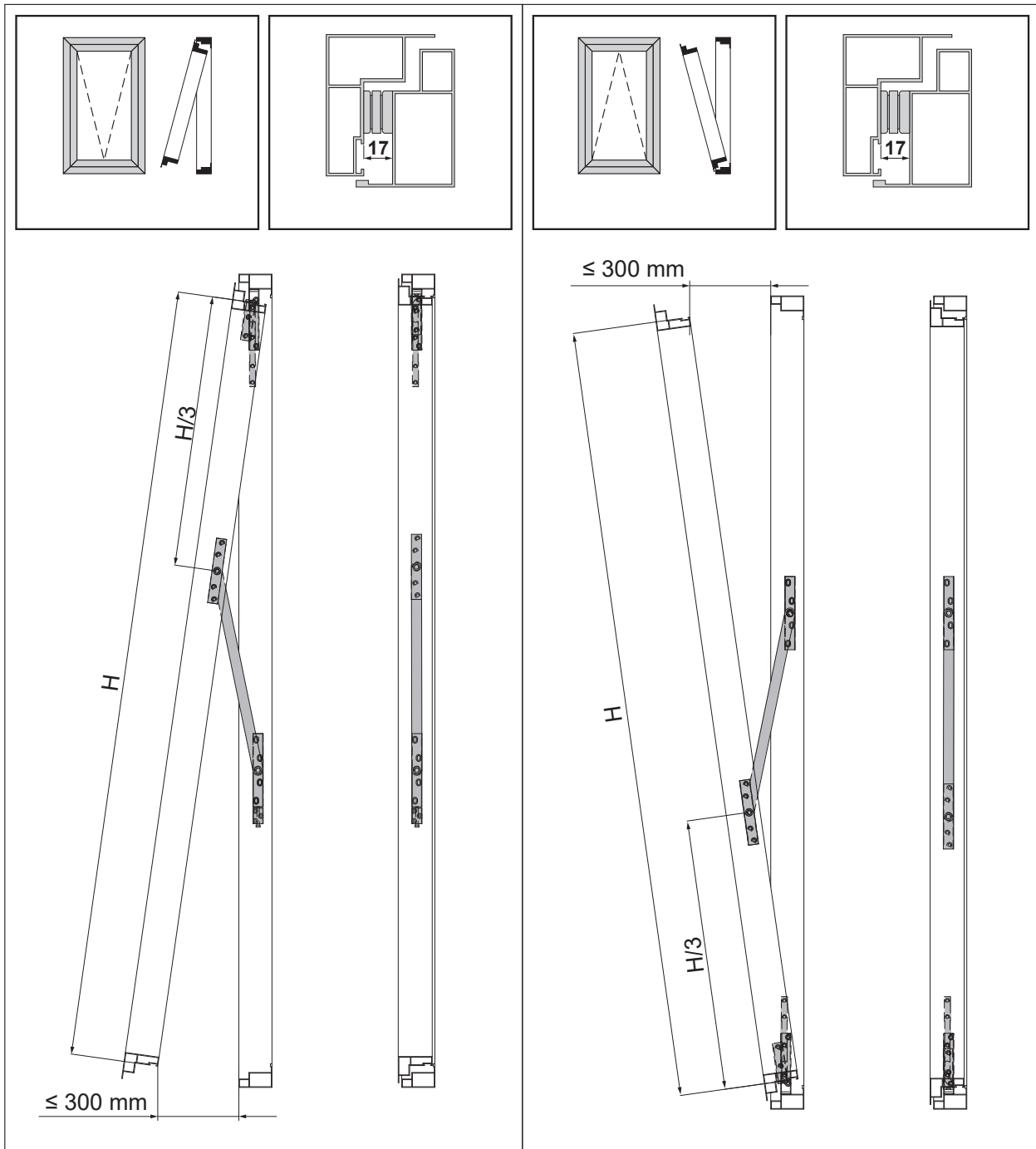

Item code	Description	Type of opening	Base Raw	Anodised Elox	Painted	Trend/Gold Brass	Pieces per pack
08500	ULK KIT FOR 17 mm STACK	Top - Bottom	X				1

ULK KIT

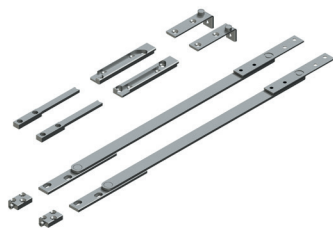

Functions

Set of components to produce top-hung or bottom-hung windows.

Online data sheet



Technical Features

The Ulk kit has been created to meet the need for Top-Hung and Bottom-Hung openings which have considerable weight and size.

Thanks to the Ulk kit, windows can be manufactured with sashes weighing up to 250 kg with Top-Hung opening and up to 300 kg with external Bottom-Hung opening (smoke vents).

The Ulk kit has been specifically designed for 17 mm door/frame stack systems, which is the sash/frame distance of all the main systems used for curtain walls.

The Ulk kit is composed of several components, all made of stainless steel: a pair of hinges, a pair of arms and a pair of adjustment devices for adjusting the sash height when Ulk is applied on Top-Hung windows.

The Ulk kit is ideal for large openings with sashes of considerable weight, for this reason it is advisable to use suitable automations for opening and closing the sash.

Top-Hung windows can be manually operated if the sash weighs less than 100 kg, but always in combination with limitation arms.

In case of Bottom-Hung openings (smoke vents) the opening must always be automated.

The maximum permitted sash opening in both Top-Hung and Bottom-Hung windows is 300 mm.

Finish

Testo di prova

Materials

AISI 304 stainless steel

Parts

- 1 pair of hinges (Right - Left)
- 1 pair of arms
- 1 height adjustment device
- 2 stop elements



OUTWARD TOP-HUNG		OUTWARD BOTTOM-HUNG	
Manual mode (*)	Load capacity ≤ 100 kg	Manual mode	Not allowed
Motorized	Load capacity ≤ 250 kg	Motorized	Load capacity ≤ 300 kg
H [mm]	1500 ÷ 3500	H [mm]	1500 ÷ 4500
W [mm]	≤ 2000	W [mm]	≤ 2000

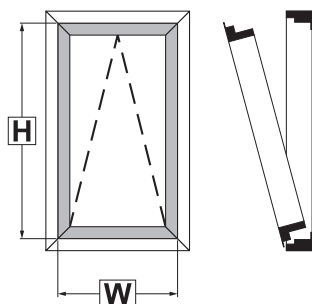
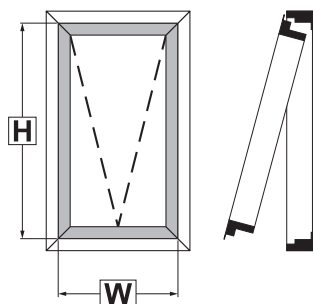

(*) With Manual Opening it is necessary to use opening limitation arms.

For the correct choice of opening limitation arms contact Giesse Technical Service.

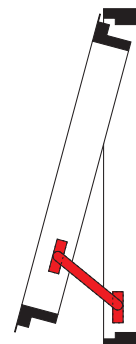

ARMS FOR BOTTOM-HUNG WINDOWS AND LIMITERS

FRIZ ARMS



Functions

Accessory utilised to limit opening of the sash when movement of the sash is restricted by obstacles such as uprights or walls.

[Online data sheet](#)



Technical Features

Sliding plate friction adjustable with a screw. Mounts to side-hung and tilt-and-turn casements with minimum dimension L = 450 mm.

As a pair, it may be used as a retainer arm for very heavy bottom-hung windows.

Equipped with a spring-loaded manual quick release.

Stop plate fitted with two grub screws to prevent slippage.

Materials

Fixing plate in zamak with GS Silver Plus finish (up to 500 h corrosion resistance)

Rod and stop plate made of pre-oxidised extruded aluminium.

Polyamide frictioning plate

Pins, screws, grub screws and release in stainless steel.

A: opening limiter. B: bottom-hung window.

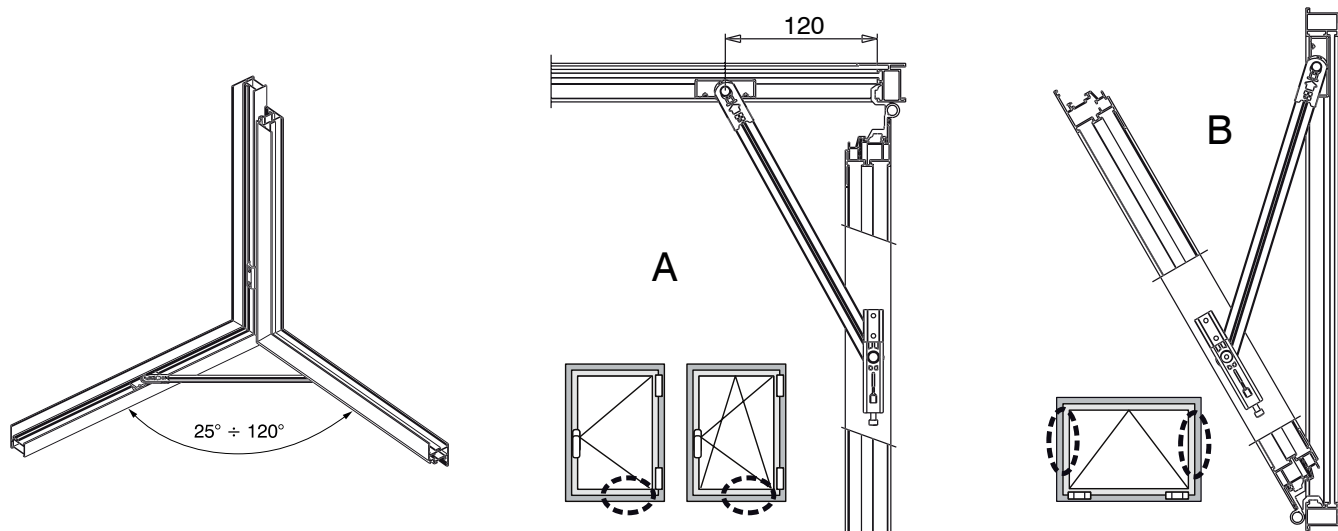

Item code	Description	PROFILE CROSS - SECTION	Rod length (mm)	Load capacity as opening limiter (kg)	Load capacity as a bottom-hung pair (kg)	Base Raw	Items per pack
02030K	FRIZ STAY LIMITATION ARM	C001-C002-C004-C011-C012-C013-C014-C015-C016-C017	300	170	130	X	10
02031K	FRIZ STAY LIMITATION ARM	C003-C005-C006	300	170	130	X	10
02034K	FRIZ STAY LIMITATION ARM	C007	300	80	70	X	10
02035	FRIZ STAY LIMITATION ARM	C008	300	80	70	X	10
02800K	FRIZ STAY LIMITATION ARM	C001-C002-C003-C004-C005-C006-C011-C012-C013-C014-C015-C016-C017	140	100	130	X	10

LIMITY ARMS

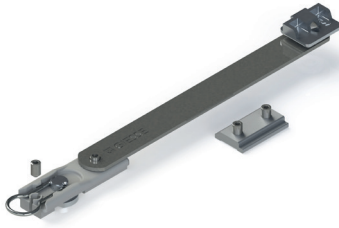

Functions

Accessory utilised to limit opening of the sash when movement of the sash is restricted by obstacles such as uprights or walls.

Online data sheet



Technical Features

Sliding plate friction adjustable by means of grub screw provided.
Can be fitted to side-hung or tilt-and-turn casements.
Equipped with a spring-loaded manual quick release.
Stop plate fitted with two grub screws to prevent slippage.

Materials

Stainless steel arm
Stainless steel spring lever
Pins, washers and grub screw in stainless steel
GS SILVER PLUS frame coupling cam and frame striker in zamak
Fibreglass reinforced polyamide slider
Extruded aluminium stop plate

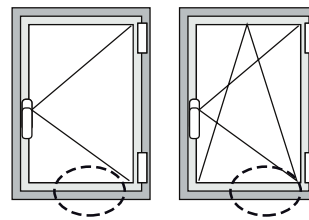
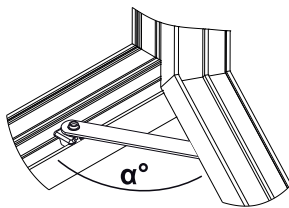

Minimum width

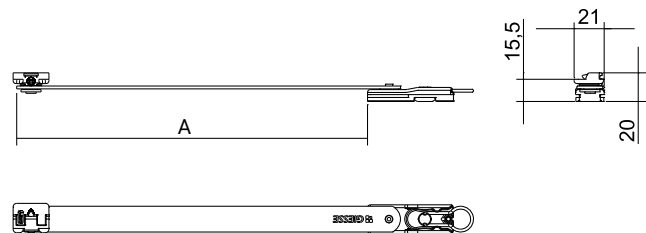
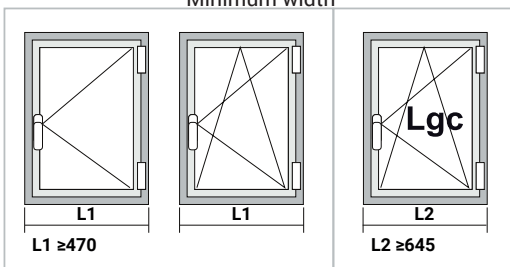

Item code	Description	PROFILE CROSS - SECTION	A (mm)	L1 (mm)	L2 (mm)	α°	Load capacity as limiter (kg)	Base Raw	Items per pack
02038	LIMITY ARM	C001-C002-C003-C004-C005-C006-C011-C012-C013-C014-C015-C016-C017	250	470	645	120°	80	X	10
02039	LIMITY ARM	C001-C002-C003-C004-C005-C006-C011-C012-C013-C014-C015-C016-C017	150	325	500	90°	80	X	10

RALLENTY ARMS

Functions

The arm delimits the opening of a bottom-hung aluminium window slowing its stroke in the stopping phase.

The arm is available in two versions: long 250 mm and short 150 mm.

Online data sheet



Technical Features

The Rallenty arm slows down the opening of the sash at the limit stop avoiding an annoying and disturbing bang on stopping (Giesse patented system). Rallenty is fixed completely by clamping, with a single Allen key size 2.5mm, without any machining or holes in the profile.

Installation is done only after completely assembling the casement, without inserting plates or anything else in advance in the channels.

Consequently, it is applied, without any operations, even on existing casements.

Rallenty is released easily from the operable sash side simply with a lever.

The release is so extremely handy as to help when tilting and turning the sash for cleaning the glass from the outside.

With Rallenty the bottom-hung window can be produced without cutting the channels.

The window maker thus avoids standard machining, done as a rule for each sash, reducing the time and therefore the cost of production.

All the materials with which the Rallenty arms are produced are corrosion resistant.

Each item refers to a pair of arms for which we identify the right (RH) and left (LH) for correct application.

Materials

Stainless steel arm

Stainless steel spring lever

Pins, washers and grub screw in stainless steel

Cams made of GS Silver Plus zamak

Fibreglass reinforced polyamide slider

H= 350÷2000 mm

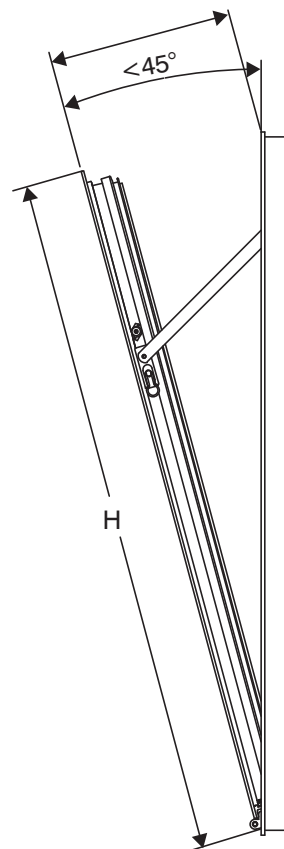

RH = right
LH = left

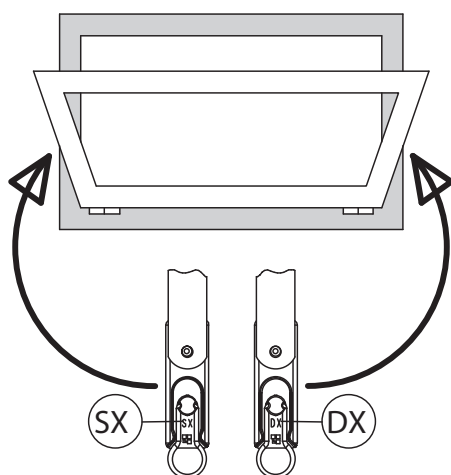

ARMS FOR BOTTOM-HUNG WINDOWS AND LIMITERS

Item code	Description	PROFILE CROSS - SECTION	Length (mm)	Load capacity (kg)	Base Raw	Items per pack
02040K	RALLENTY LONG ARM 250 mm	C001-C002-C003-C004-C005-C006-C011-C012-C013-C014-C015-C016-C017	250	80	X	10
02041K	RALLENTY SHORT ARM 150 mm	C001-C002-C003-C004-C005-C006-C011-C012-C013-C014-C015-C016-C017	150	50	X	10
02042K	RALLENTY LONG ARM 250 mm	C007	250	70	X	10
02043K	RALLENTY SHORT ARM 150 mm	C007	150	50	X	10
0204401	RALLENTY LONG ARM 250 mm	C008	250	70	X	10
0204501	RALLENTY SHORT ARM 150 mm	C008	150	50	X	10
0204601	RALLENTY LONG ARM 250 mm	C009	250	70	X	10
0204701	RALLENTY SHORT ARM 150 mm	C009	150	50	X	10

LIMITATION ARMS WITH BLOCK



Functions

The limitation arm with block limits the Top-hung or Side-hung sash to a maximum opening position and is able to lock it in that position by movement of the mechanism.

Online data sheet



Technical Features

For safety reasons, it is often required that the sash can be locked in its maximum limited opening position. Giesse has devised a new concept of secure outward opening: the closing system, by means of the rotation of the window handle/cremone, is able to keep the sash locked in its maximum limited opening position but, if necessary, it also allows the sash to move to the "fully open" position.

In a Top Hung or Side hung window, by applying 2 limitation arms with block, in combination with other Giesse products, the following opening types can be obtained:

- closed sash and gripped locking points: handle operated at 0°
- sash which can be opened freely up to the maximum limitation position: handle operated at 90°
- sash in maximum locked opening position: handle operated at 0°
- sash which can be opened up to the maximum opening position: operated at 180°

The product is applicable in top-hung systems with stack (sash/frame distance) of 17 mm.

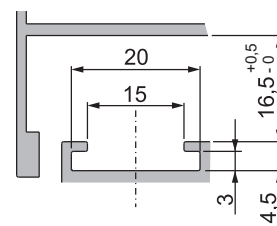

Top-Hung configuration example

Description	Qty	Item code
Limitation arm with lock	2	01700
Ghibo Plus CW1 mechanism	1	02079
Futura corner drive	2	04020K
Fixed pawl	4	04049
Adjustable striker for frame	4	01396
Window handle	1	product selected from the Giesse catalogue
Sash centering and lifting unit	2	01717
Burglar bolt for curtain wall	1	01410

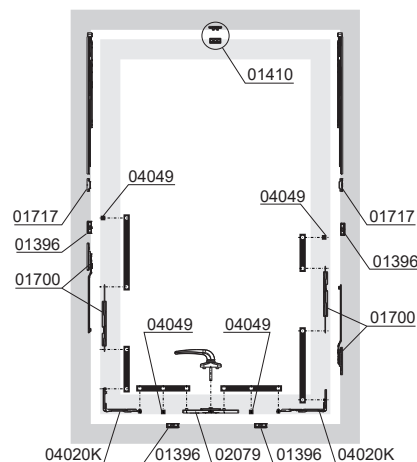

Side-Hung configuration example

Description	Qty	Item code
Limitation arm with lock	2	01700
Rod driving device	1	04098001/04099001
Futura corner drive	2	04020K
Fixed pawl	4	04049
Adjustable striker for frame	4	01396
Unica one-way cremone	1	depends on profile geometry
Sash centering and lifting unit	1	01717

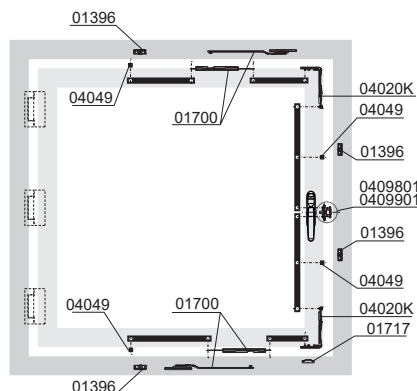

Item code	Description	Note	Base Raw	Anodised Elox	Painted	Trend/Gold Brass	Pieces per pack
01700	LIMITATION ARM WITH BLOCK	17 mm stack	X				10

 **GIESSE**

**COMPLETE
SYSTEMS
FOR HANDLING
AND CLOSING**



2-STAR SKG - TILT-AND-TURN SYSTEMS

2-STAR SKG - TILT-AND-TURN SYSTEMS

Functions

Giesse offers for Tilt-and-Turn windows with a single and double sash, a complete burglar-proof closing system with SKG** certification issued by IKOB SKG (Netherlands).

The use of premium materials (such as microcast steel) is essential for strengthening the components and connection devices and ensures the closing system is designed to withstand attempted burglaries and direct attacks.

Technical Features

The SKG** system consists of:

- Mechanism - SKG** Cremone with key
- SKG** Tilt-and-Turn mechanism
- Arms and Tilt-and-Turn hinges - CHIC or FUTURA
- SKG** Burglar-proof fastening mechanism components

The combination of these components in line with variations in the sash dimensions ensures that the Giesse closing system is strong enough to be defined as burglar-proof, with RC2 classification in accordance with EN1627. System certification in accordance with EN1627, however, corresponds to the whole casement: hardware, profile, glass, wall fixings, etc.

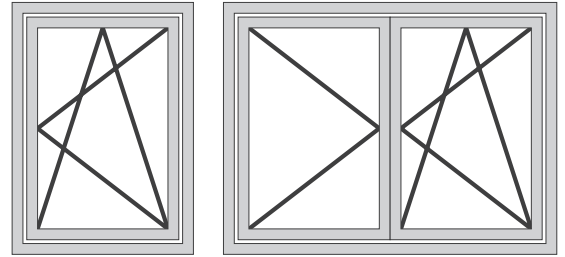

The rods used with the SKG certified closing system must be made using Aluminium.

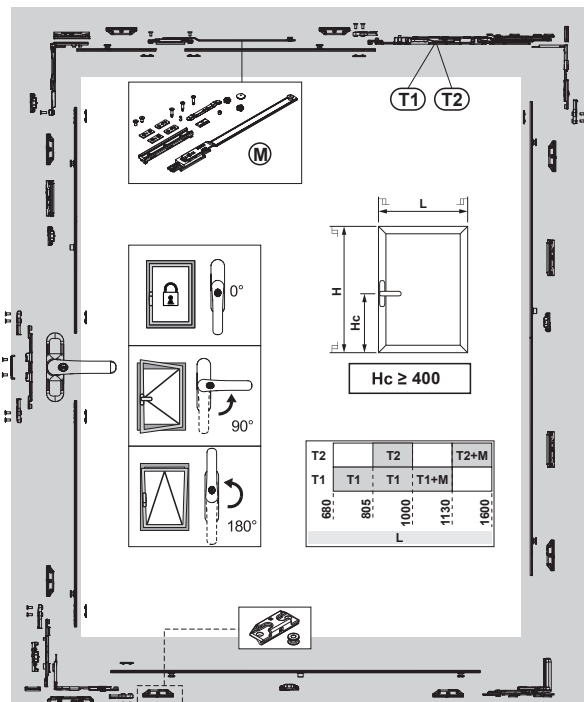
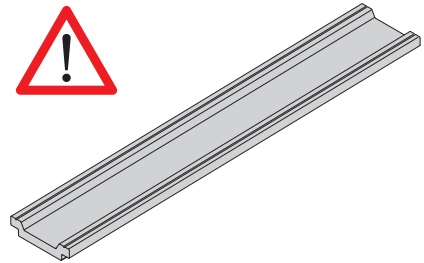

Single CHIC tilt-and-turn window - Configuration with 1000x1500 mm sash (LxH)

Quantity	Item code	Description
1	0108501 or 0119102 or 00960	Cremone
1	04007	Tilt-and-Turn window kit
8	04000	Burglar-proof fastening mechanism
1	043561 - 043562	CHIC - Tilt-and-Turn window kit, T2 arm (RH or LH)

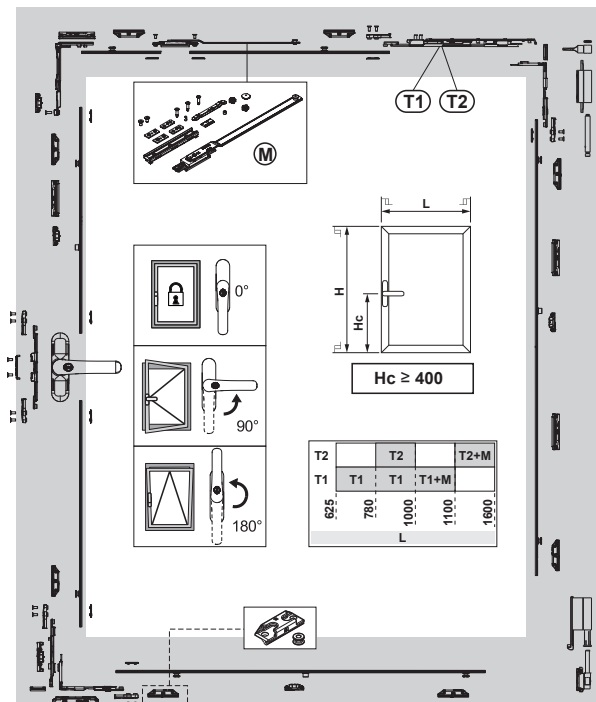

Single FUTURA tilt-and-turn window - Configuration with 1000x1500 mm sash (LxH)

Quantity	Item code	Description
1	0108501 or 0119102 or 00960	Cremone
1	04007	Tilt-and-Turn window kit
8	04000	Burglar-proof fastening mechanism
1	04285	T2 arm 130
1	04711	Tilt-and-Turn window hinge



Double CHIC tilt-and-turn window - Configuration with 1000x1500 mm sash (LxH)

Quantity	Item code	Description
2	0108501 or 0119102 or 00960	Cremone
2	04007	Tilt-and-Turn window kit
14	04000	Burglar-proof fastening mechanism
1	043551/2 + 043561/2	CHIC - Tilt-and-Turn window kit, T1/T2 arm (RH or LH)

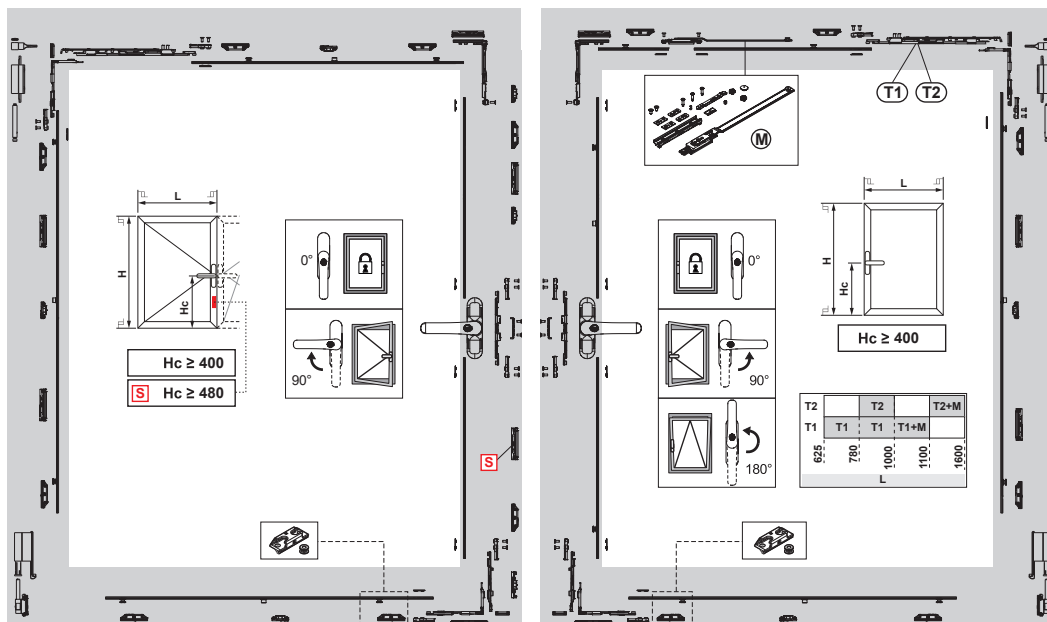

Double FUTURA tilt-and-turn window - Configuration with 1000x1500 mm sash (LxH)

Quantity	Item code	Description
2	0108501 or 0119102 or 00960	Cremone
2	04007	Tilt-and-Turn window kit
14	04000	Burglar-proof fastening mechanism
1	04284 + 04285	T1/T2 arm 130
2	04711	Tilt-and-Turn window hinge

2-STAR SKG - TILT-AND-TURN SYSTEMS

SKG - CREMONES

Functions

Reversible cremone with key lockable handle, with rotation through 90° and 180° and opening/closing positioning notch.

Online data sheet



Technical Features

SKG*** certified, the cylinder makes it possible to lock the handle at 0° with a rotation and tear breaking strength greater than 100 Nm.

The cylinders of the FIRST KEY cremones have homogeneous coding, on request it is in any case possible to fulfill specific job orders with customized coding.

Materials

Handle in die-cast aluminium

Die-cast Zamak case, gears, racks and sliding parts

Nickel-plated brass cylinder

Internal sheath and Hostaform plate

Spring, screws and fixing plate in stainless steel

Parts

1 fixing plate

2 HSHC screws M5x14



0108501

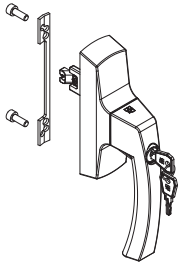

00960

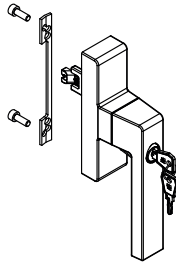

0119102

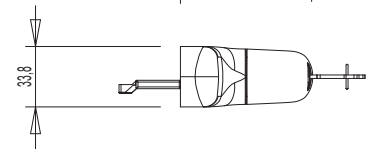
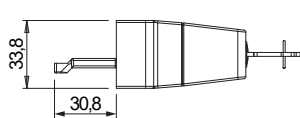
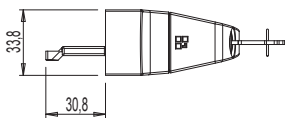
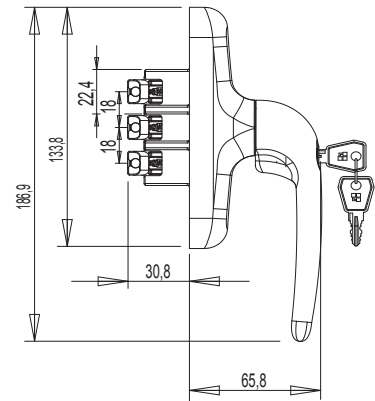
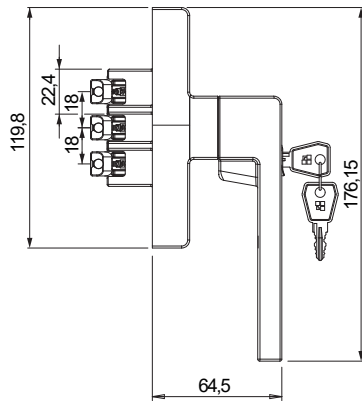
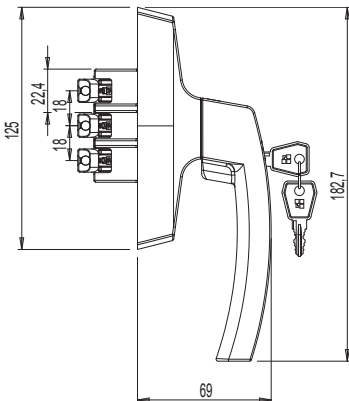
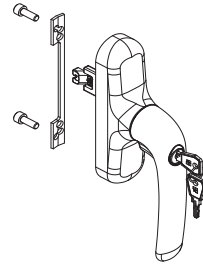

Item code	Description	Note	Base Raw	Anodised Elox	Painted	Trend/Gold Brass	Pieces per pack
0108501	SKG ASIA KEY MICRO CREMONE		X		X		5
0119102	SKG PRIMA KEY MICRO CREMONE		X		X		5
00960	SKG KORA KEY MICRO CREMONE		X		X		5

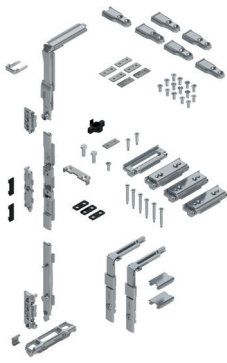

SKG - TILT-AND-TURN WINDOW KIT

Functions

Tilt-and-Turn fastening mechanism available in standard version.

Online data sheet



Technical Features

Perimetral closing: the 3 corner drives supplied allow closing on all sides. In relation to a standard product, it includes strengthening components for the joints with the rod.

4 adjustable shims reduce sideways movement of the sash, increasing its resistance to burglary.

Materials

Corner drives, drive rod, mechanism bolt tip and strikers in zamak with GS Silver Plus finish (up to 500 h of corrosion resistance)

Sash/frame shimming components in GS Silver Plus zamak

Rod strengthening components in microcast steel

Screws and grub screws in stainless steel



Rod strengthening components

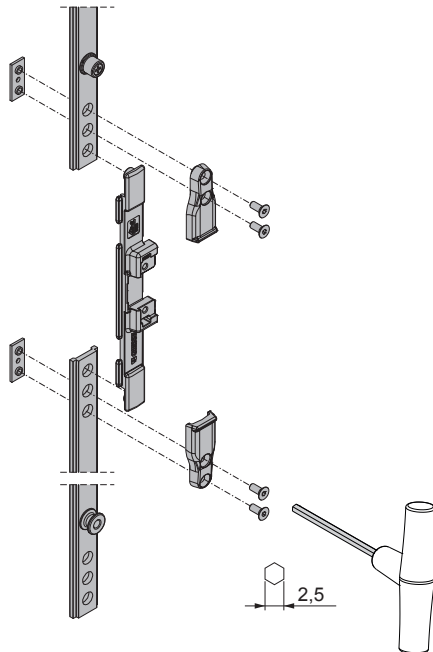

Adjustable side shims

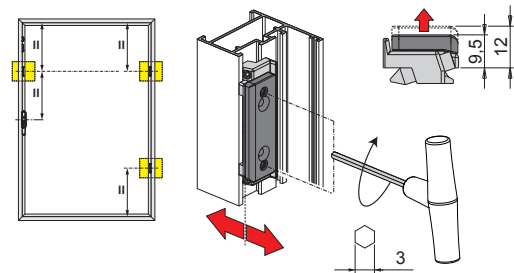

Top shim

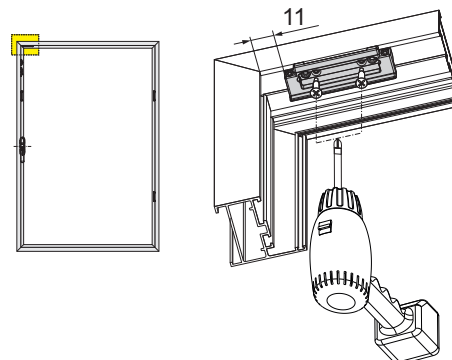

Item code	Description	Note	Base Raw	Anodised Elox	Painted	Trend/Gold Brass	Pieces per pack
04007	SKG - TILT-AND-TURN WINDOW KIT		X				5

2-STAR SKG - BURGLAR-PROOF FASTENING MECHANISM



Functions

Specially designed device to increase resistance of the tilt-and-turn window to break-in attempts, making intrusion through the window more difficult.

Online data sheet



Technical Features

Article composed of two elements: the striker to be applied to the frame and the mushroom pawl to be applied to the rod. The striker is reversible and is secured to the frame by means of the pre-assembled grub screw and two self-threading screws that ensure precise, quick fixing to the frame. The pawl is applied to the rod of the series by simply making a hole $\varnothing 8$ mm; thanks to this solution, using the burglar-proof kit requires no changes to the cutting.

Materials

Striker in zamak with GS SILVER PLUS finish (over 500 hours of corrosion resistance)
Pawl and screws in stainless steel.



04000

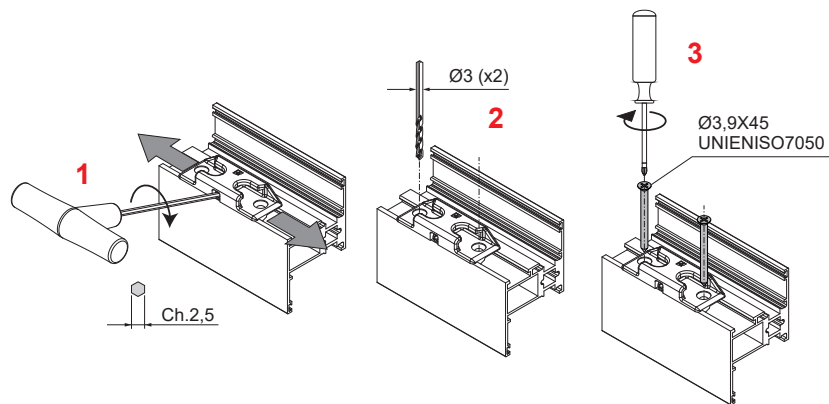
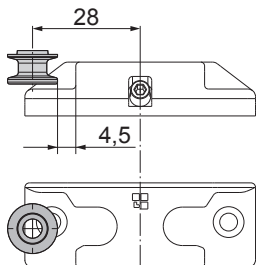
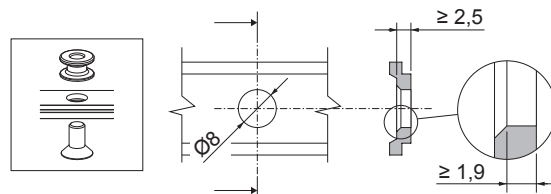
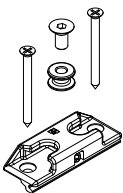

Item code	Description	Note	Base Raw	Anodised Elox	Painted	Trend/Gold Brass	Pieces per pack
04000	2-STAR SKG BURGLAR-PROOF FASTENING MECHANISM		X				20

SKG - ADDITIONAL ARM



Functions

Additional arm for combination with the type 1 or type 2 arm on casements more than 1000 mm wide, installed to distribute the sash opening force during bottom-hung opening. Specifically reinforced to achieve SKG certification.

Online data sheet



Technical Features

The additional arm is fitted to the cross-beam on opposite side to the arm (drive side) on sashes more than 1000 mm wide to prevent excessive leverage, which might impair operation of the window, during bottom-hung opening. The arm consists of a component for connection to the corner driver without fixing screws, a rod and a slider which is fixed to the frame using three self-tapping screws provided.

The integral rod fixing utilises specific screws and plates.

Materials

- Stainless steel arm
- Slider and fixing plug in GS SILVER PLUS zamak
- Polyamide shim
- Screws and grub screws in stainless steel

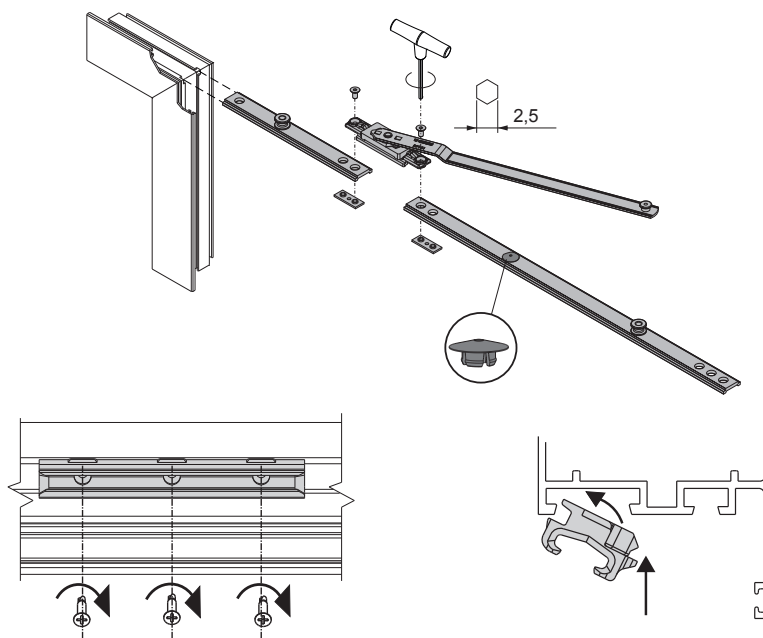
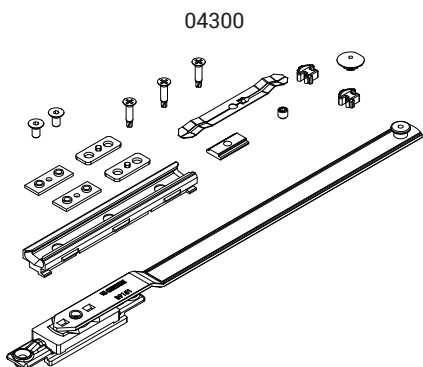
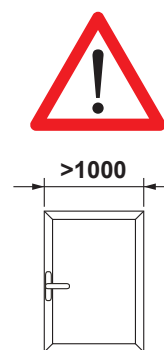

Item code	Description	Note	Base Raw	Anodised Elox	Painted	Trend/Gold Brass	Pieces per pack
04300	SKG - ADDITIONAL ARM		X				5

SKG - CHIC 100 TILT-AND-TURN HINGES AND ARMS

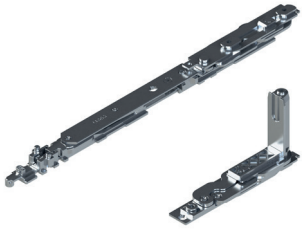

Functions

Hinge kit (upper and lower), completely pre-assembled and ready to be installed on the profile.

Online data sheet



Technical Features

They enable tilt-and-turn opening combined with the mechanisms.
Micro-ventilation and logica versions.
The arm is equipped with micro-ventilation as standard (adjustable).
Moving the fastening pawl takes the arm from conventional to logica.
The T2 arm is adjustable: the opening "A" goes from 178 mm (base) to 148 mm.

Materials

Corner support made of zamak
Connecting brackets and hinge plates made of zinc plated steel
Pins made of 304 grade stainless steel and aluminium bronze
Cams made of zinc plated steel
Connecting bracket and arm rod made of 304 grade stainless steel

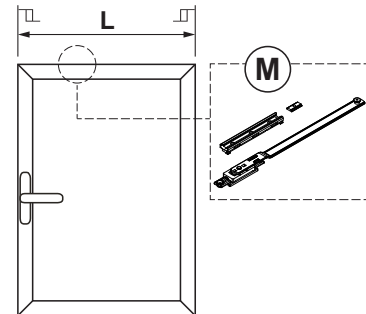

T2		T2		T2+M
T1	T1	T1	T1+M	
680	805	1000	1130	1600
L				

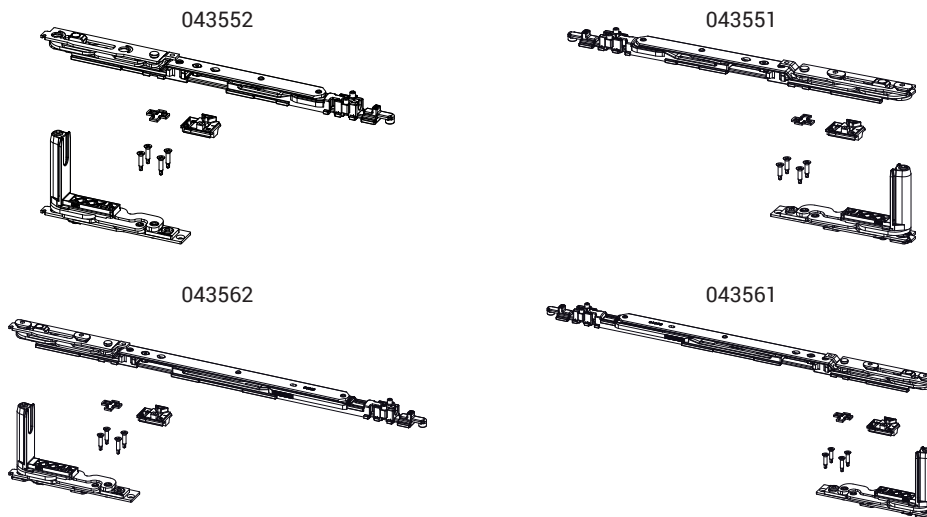

Sash opening



Item code	Description	PROFILE CROSS - SECTION	A (mm)	Hand	Base Raw	Anodised Elox	Painted	Trend/Gold Brass	Pieces per pack
043551	CHIC - T1 ARM T&T KIT	C001-C002-C003-C005-C006	98	RX	X				10
043552	CHIC - T1 ARM T&T KIT	C001-C002-C003-C005-C006	98	LX	X				10
043561	CHIC - T2 ARM T&T KIT	C001-C002-C003-C005-C006	148÷178	RX	X				10
043562	CHIC - T2 ARM T&T KIT	C001-C002-C003-C005-C006	148÷178	LX	X				10

SKG - CHIC 130 TILT-AND-TURN HINGES AND ARMS



Functions

Set of hinges (top and bottom), completely pre-assembled and ready to be installed on the profile.

Online data sheet



Technical Features

They enable tilt-and-turn opening combined with the mechanisms.
 Micro-ventilation and logica versions.
 The arm is equipped with micro-ventilation as standard (adjustable).
 Moving the fastening pawl takes the arm from conventional to logica.
 The T2 arm is adjustable: the opening "A" goes from 178 mm (base) to 148 mm.

Materials

Corner support made of zamak
 Connecting brackets and hinge plates made of zinc plated steel
 Pins made of 304 grade stainless steel and aluminium bronze
 Cams made of zinc plated steel
 Connecting bracket and arm rod made of 304 grade stainless steel

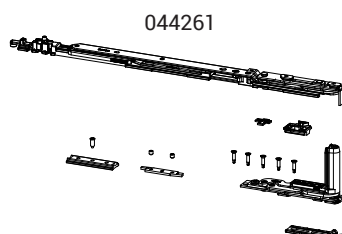
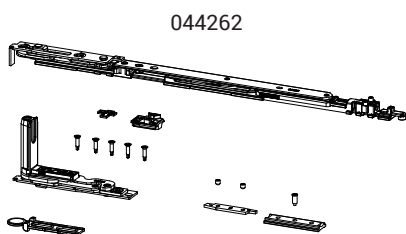
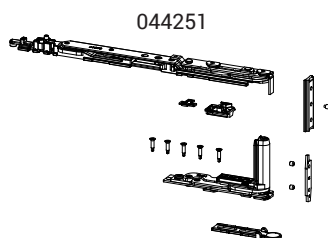
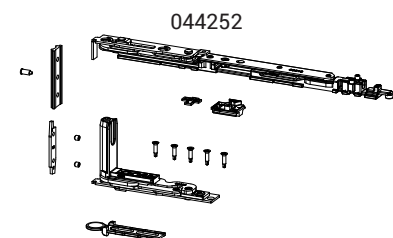
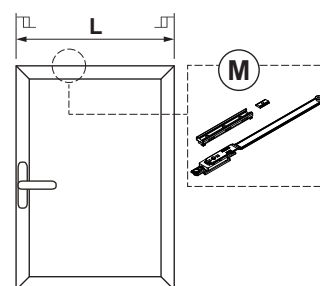

T2		T2		T2+M
T1	T1	T1	T1+M	
680	805	1000	1130	1600
L				

Sash opening

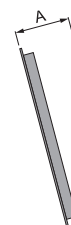

Item code	Description	PROFILE CROSS - SECTION	A (mm)	Hand	Base Raw	Anodised Elox	Painted	Trend/Gold Brass	Pieces per pack
044251	CHIC - T1 ARM T&T KIT	C001	98	RX	X				10
044252	CHIC - T1 ARM T&T KIT	C001	98	LX	X				10
044261	CHIC - T2 ARM T&T KIT	C001	148÷178	RX	X				10
044262	CHIC - T2 ARM T&T KIT	C001	148÷178	LX	X				10

SKG - FUTURA 3D 130 HINGES AND ARMS



Functions

Futura 3D 130 tilt-and-turn hinge set (upper and lower) and arm.

Online data sheet



Technical Features

Hinges: hinge set (upper and lower), completely pre-assembled and ready to be installed on the profile.

Arms: allow tilt-and-turn opening in conjunction with tilt-and-turn hinges and mechanisms.

Materials

Hinges:

- Body of hinges in extruded aluminium and brass
- Supports in zamak with GS Silver Plus finish (up to 500 h corrosion resistance)
- Pins, screws and grub screws in stainless steel

Arms:

- Body, fixing block and slider in zamak with GS Silver Plus finish (up to 500 h corrosion resistance)
- Rod, connecting bracket, grub screws and screws in stainless steel
- Stop disk in polyamide

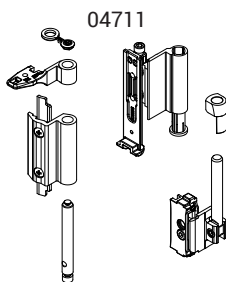
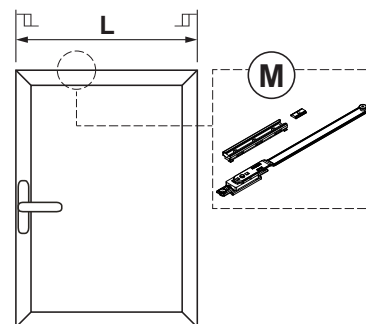

04284

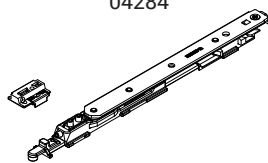

04285

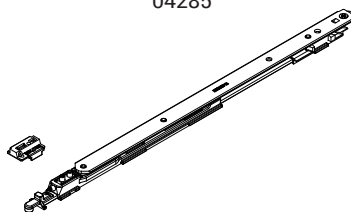

T2		T2		T2+M
T1	T1	T1	T1+M	
	625	780	1000	1100
	L			

Sash opening



Item code	Description	PROFILE CROSS - SECTION	Base Raw	Anodised Elox	Painted	Trend/Gold Brass	Pieces per pack
04711	HINGE T/T FUTURA 130	C001-C002-C003-C005-C006	X		X	X	10

Item code	Description	PROFILE CROSS - SECTION	A (mm)	Base Raw	Anodised Elox	Painted	Trend/Gold Brass	Pieces per pack
04284	ARM T1 130 WITH MICROVENTILATION	C001-C002-C003-C015-C016-C017	120					10
04285	ARM T2 130 WITH MICROVENTILATION	C001-C002-C003-C015-C016-C017	175					10

2-STAR SKG - SIDE-HUNG SYSTEMS



Functions

Giesse offers for single and double sash windows a complete burglar-proof closing system with SKG** certification issued by IKOB SKG (Netherlands). The use of premium materials (such as microcast steel) is essential for strengthening the components and connection devices and ensures the closing system is designed to withstand attempted burglaries and direct attacks.

Technical Features

As it is a system which requires locking points on all sides, the tilt-and-turn arms must be used to allow the application of burglar-proof fastening mechanisms to the hinge side.

The SKG** system consists of:

- Mechanism - SKG** Cremone with key
- SKG** Side-Hung mechanism
- Arms and TILT-AND-TURN hinges - CHIC or FUTURA
- SKG** Burglar-proof fastening mechanism components

The combination of these components in line with variations in the sash dimensions ensures that the Giesse closing system is strong enough to be defined as burglar-proof, with RC2 classification in accordance with EN1627. System certification in accordance with EN1627, however, corresponds to the whole casement: hardware, profile, glass, wall fixings, etc.

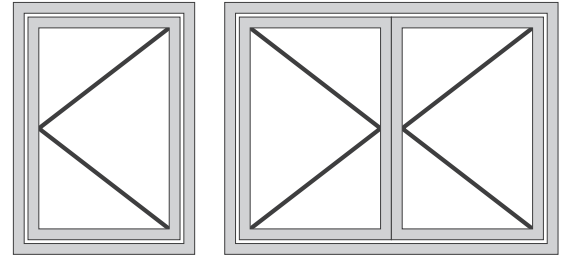

The rods used with the SKG certified closing system must be made using Aluminium.

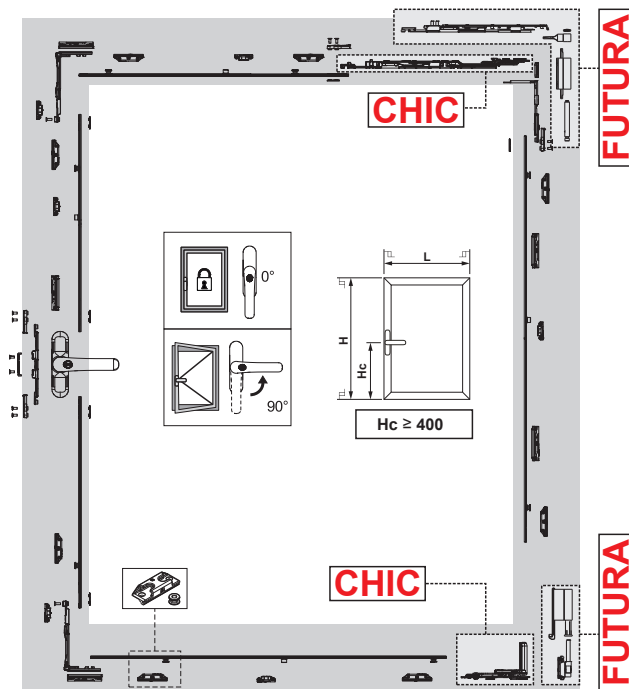
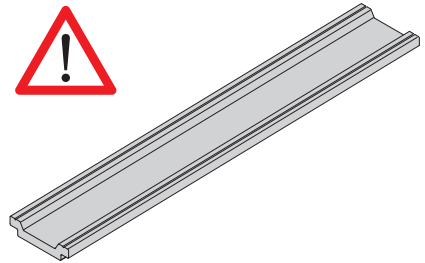

Single CHIC side-hung window - Configuration with 1000x1500 mm sash (LxH)

Quantity	Item code	Description
1	0108501 or 0119102 or 00960	Cremone
1	04005	Side-Hung window kit
8	04000	Burglar-proof fastening mechanism
1	043561 - 043562	CHIC - Tilt-and-Turn window kit, T2 arm (RH or LH)

Single FUTURA side-hung window - Configuration with 1000x1500 mm sash (LxH)

Quantity	Item code	Description
1	0108501 or 0119102 or 00960	Cremone
1	04005	Side-Hung window kit
8	04000	Burglar-proof fastening mechanism
1	04285	T2 arm 130
1	04711	Tilt-and-Turn window hinge

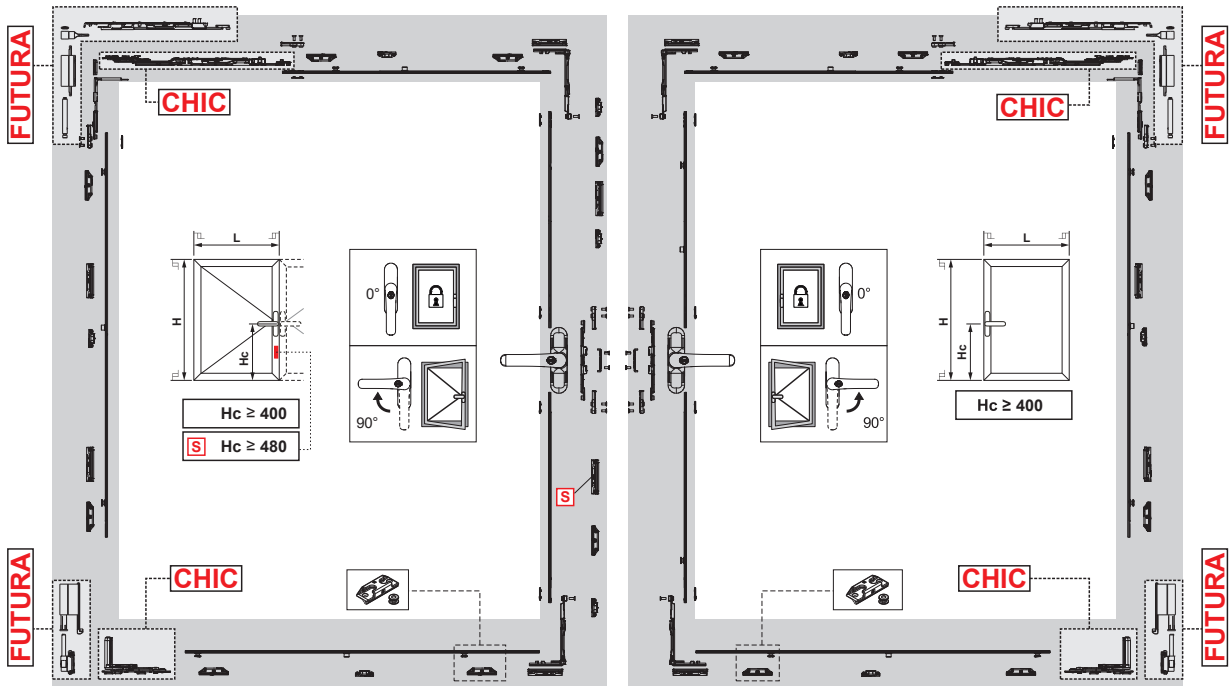

Double CHIC side-hung window - Configuration with 1000x1500 mm sash (LxH)

Quantity	Item code	Description
2	0108501 or 0119102 or 00960	Cremona
2	04005	Side-Hung window kit
14	04000	Burglar-proof fastening mechanism
2	043561 or 043562	CHIC - Tilt-and-Turn window kit, T2 arm (RH or LH)

Double FUTURA side-hung window - Configuration with 1000x1500 mm sash (LxH)

Quantity	Item code	Description
2	0108501 or 0119102 or 00960	Cremona
2	04005	Side-Hung window kit
14	04000	Burglar-proof fastening mechanism
2	04285	T2 arm 130
2	04711	Tilt-and-Turn window hinge



SKG - CREMONES

Functions

Reversible cremone with key lockable handle, with rotation through 90° and 180° and opening/closing positioning notch.

Online data sheet



Technical Features

SKG*** certified, the cylinder makes it possible to lock the handle at 0° with a rotation and tear breaking strength greater than 100 Nm.

The cylinders of the FIRST KEY cremones have homogeneous coding, on request it is in any case possible to fulfill specific job orders with customized coding.

Materials

Handle in die-cast aluminium

Die-cast Zamak case, gears, racks and sliding parts

Nickel-plated brass cylinder

Internal sheath and Hostaform plate

Spring, screws and fixing plate in stainless steel

Parts

1 fixing plate

2 HSHC screws M5x14



0108501

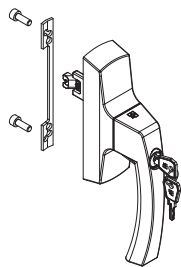

00960

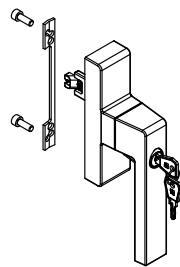

0119102

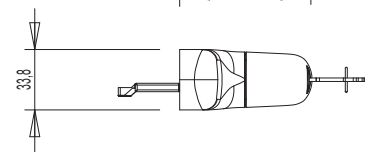
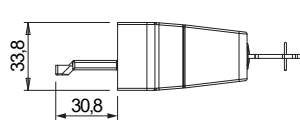
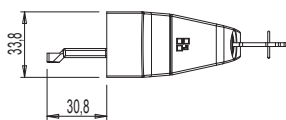
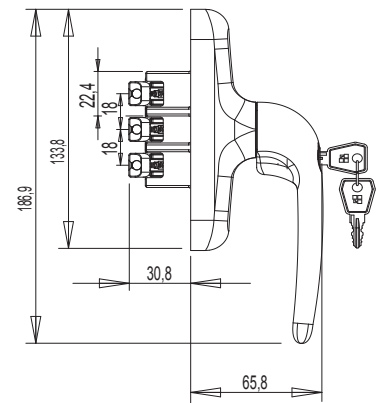
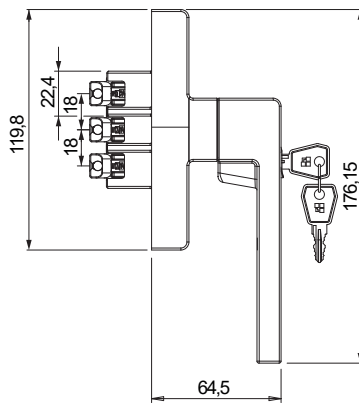
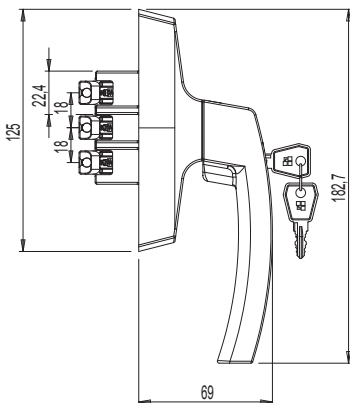
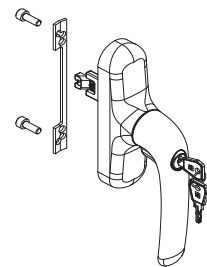

Item code	Description	Note	Base Raw	Anodised Elox	Painted	Trend/Gold Brass	Pieces per pack
0108501	SKG ASIA KEY MICRO CREMONE		X		X		5
0119102	SKG PRIMA KEY MICRO CREMONE		X		X		5
00960	SKG KORA KEY MICRO CREMONE		X		X		5

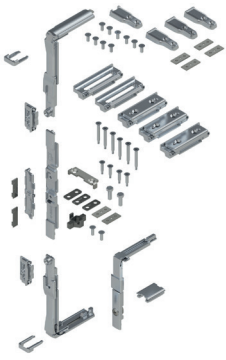

SKG - SIDE-HUNG WINDOW KIT

Functions

Side-Hung fastening mechanisms.

[Online data sheet](#)



Technical Features

Perimetral closing: the 3 corner drives supplied allow closing on all sides. In relation to a standard product, it includes strengthening components for the joints with the rod.

4 adjustable shims reduce sideways movement of the sash, increasing its resistance to burglary.

Materials

Corner drives, drive rod, mechanism bolt tip and strikers in zamak with GS Silver Plus finish (up to 500 h of corrosion resistance)

Sash/frame shimming components in GS Silver Plus zamak

Rod strengthening components in microcast steel

Screws and grub screws in stainless steel



Rod strengthening components

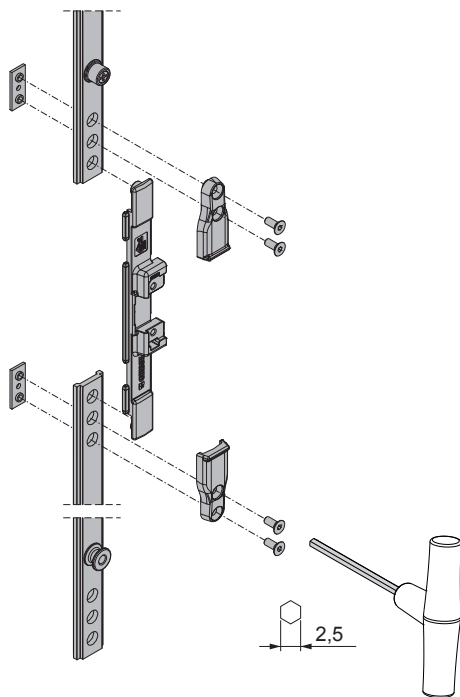

Adjustable side shims

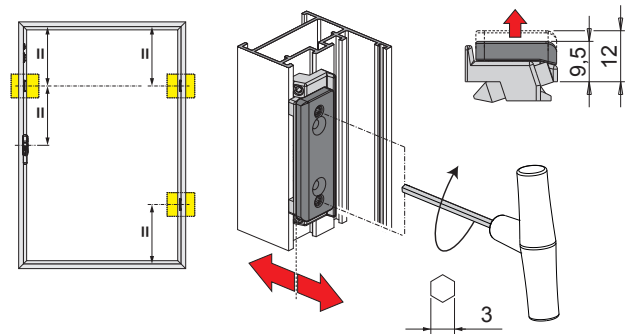

Top shim

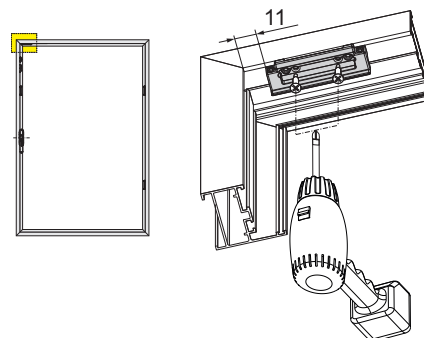

Item code	Description	Note	Base Raw	Anodised Elox	Painted	Trend/Gold Brass	Pieces per pack
04005	SKG - SIDE-HUNG KIT		X				5

2-STAR SKG - BURGLAR-PROOF FASTENING MECHANISM



Functions

Specially designed device to increase resistance of the tilt-and-turn window to break-in attempts, making intrusion through the window more difficult.

Online data sheet



Technical Features

Article composed of two elements: the striker to be applied to the frame and the mushroom pawl to be applied to the rod. The striker is reversible and is secured to the frame by means of the pre-assembled grub screw and two self-threading screws that ensure precise, quick fixing to the frame. The pawl is applied to the rod of the series by simply making a hole $\varnothing 8$ mm; thanks to this solution, using the burglar-proof kit requires no changes to the cutting.

Materials

Striker in zamak with GS SILVER PLUS finish (over 500 hours of corrosion resistance)
Pawl and screws in stainless steel.



04000

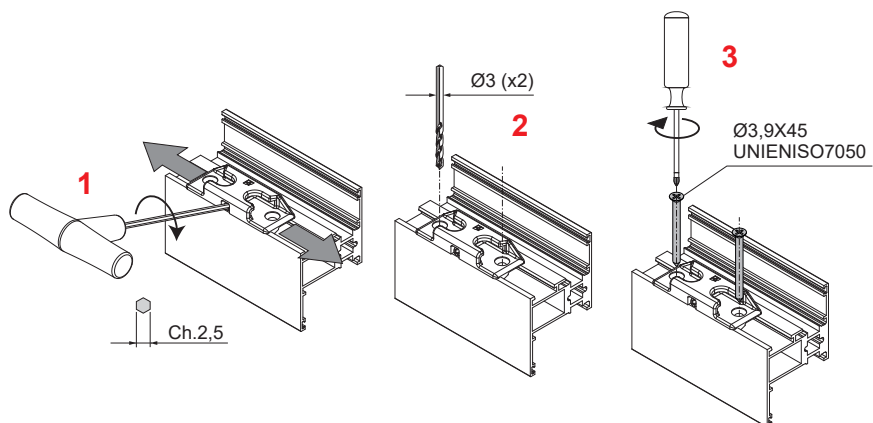
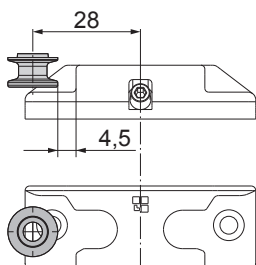
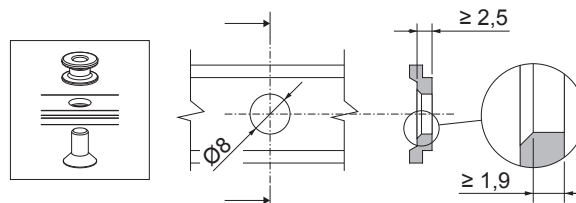
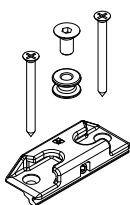

Item code	Description	Note	Base Raw	Anodised Elox	Painted	Trend/Gold Brass	Pieces per pack
04000	2-STAR SKG BURGLAR-PROOF FASTENING MECHANISM		X				20

SKG - CHIC 100 SIDE-HUNG HINGES AND ARMS

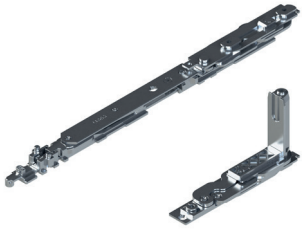

Functions

Set of hinges (top and bottom) for side-hung or secondary sash with tilt-and-turn CHIC 3D 100.

Online data sheet



Technical Features

Sash opening to 180°. Maximum load capacity 100 kg. Assembly is simple, fast and easy using the special pre-assembled cams. When there is an additional fastening mechanism, you need to use the CHIC fastening element. Both hinges are adjustable (3D). If opening is obstructed, you need to use the FRIZ limitation arm.
CAUTION: This hinge is designed to be used only on inward opening casements and is not suitable for outward opening casements.

Materials

Corner support made of zamak
 Connecting brackets and hinge plates made of zinc plated steel
 Pins made of 304 grade stainless steel and aluminium bronze
 Cams made of zinc plated steel

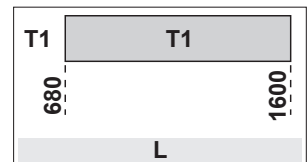
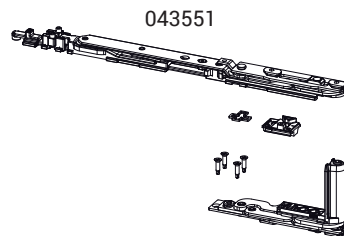
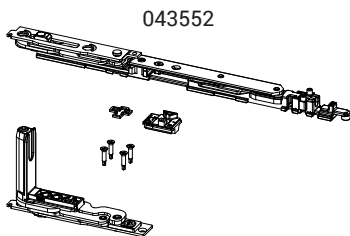
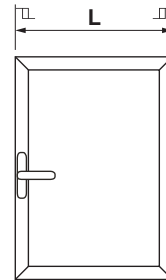

Sash opening



Item code	Description	PROFILE CROSS - SECTION	A (mm)	Hand	Base Raw	Anodised Elox	Painted	Trend/Gold Brass	Pieces per pack
043551	CHIC - T1 ARM T&T KIT	C001-C002-C003-C005-C006	98	RX	X				10
043552	CHIC - T1 ARM T&T KIT	C001-C002-C003-C005-C006	98	LX	X				10

SKG - CHIC 130 SIDE-HUNG HINGES AND ARMS

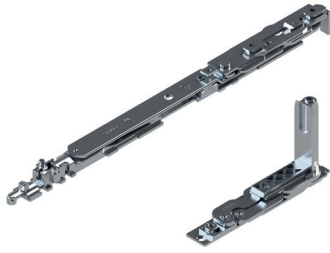

Functions

Set of hinges (top and bottom) for side-hung or secondary sash with tilt-and-turn CHIC 3D 130.

Online data sheet



Technical Features

Sash opening to 180°. Maximum load capacity 130 kg. Assembly is simple, fast and easy using the special pre-assembled cams. When there is an additional fastening mechanism, you need to use the CHIC fastening element. Both hinges are adjustable (3D). If opening is obstructed, you need to use the FRIZ limitation arm. **CAUTION:** This hinge is designed to be used only on inward opening casements and is not suitable for outward opening casements.

Materials

Corner support made of zamak
Connecting brackets and hinge plates made of zinc plated steel
Pins made of 304 grade stainless steel and aluminium bronze
Cams made of zinc plated steel

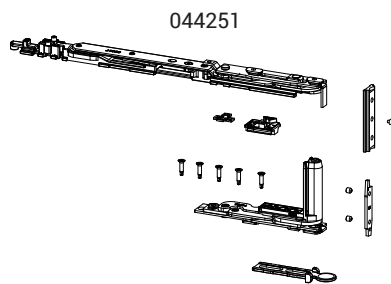
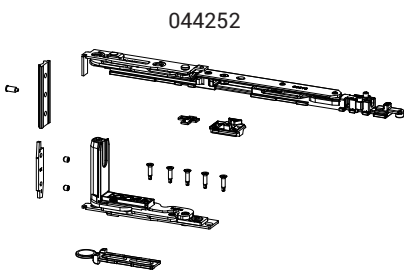
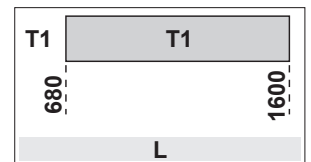
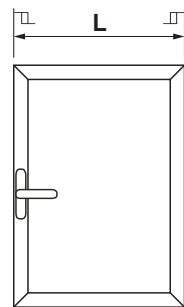

Sash opening

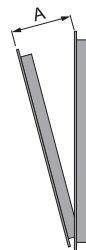

Item code	Description	PROFILE CROSS - SECTION	A (mm)	Hand	Base Raw	Anodised Elox	Painted	Trend/Gold Brass	Pieces per pack
044251	CHIC - T1 ARM T&T KIT	C001	98	RX	X				10
044252	CHIC - T1 ARM T&T KIT	C001	98	LX	X				10

SKG - FUTURA 3D 130 HINGES AND ARMS



Functions

Futura 3D 130 tilt-and-turn hinge set (upper and lower) and arm.

Online data sheet



Technical Features

Hinges: hinge set (upper and lower), completely pre-assembled and ready to be installed on the profile.

Arms: allow tilt-and-turn opening in conjunction with tilt-and-turn hinges and mechanisms.

Materials

Hinges:

- Body of hinges in extruded aluminium and brass
- Supports in zamak with GS Silver Plus finish (up to 500 h corrosion resistance)
- Pins, screws and grub screws in stainless steel

Arms:

- Body, fixing block and slider in zamak with GS Silver Plus finish (up to 500 h corrosion resistance)
- Rod, connecting bracket, grub screws and screws in stainless steel
- Stop disk in polyamide

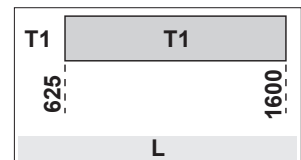
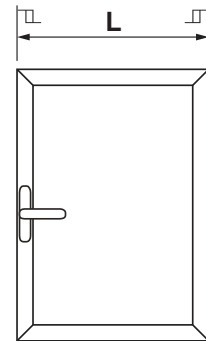

04711

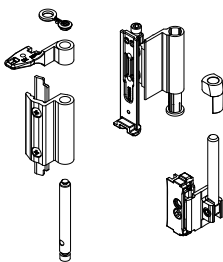

04284

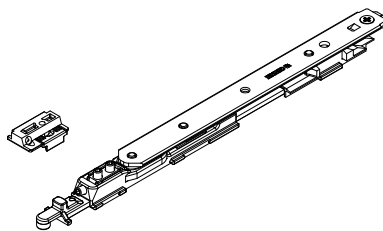

Sash opening



Item code	Description	PROFILE CROSS - SECTION	Base Raw	Anodised Elox	Painted	Trend/Gold Brass	Pieces per pack
04711	HINGE T/T FUTURA 130	C001-C002-C003-C005-C006	X		X	X	10

Item code	Description	PROFILE CROSS - SECTION	A (mm)	Base Raw	Anodised Elox	Painted	Trend/Gold Brass	Pieces per pack
04284	ARM T1 130 WITH MICROVENTILATION	C001-C002-C003-C015-C016-C017	120					10

3-STAR SKG - TILT-AND-TURN SYSTEMS

Functions

Giesse offers for Tilt-and-Turn windows with a single and double sash, a complete burglar-proof closing system with SKG*** certification issued by IKOB SKG (Netherlands).

The use of premium materials (such as microcast steel) is essential for strengthening the components and connection devices and ensures the closing system is designed to withstand attempted burglaries and direct attacks.

Technical Features

The SKG*** system consists of:

- Mechanism - SKG*** Cremone with key
- SKG*** Tilt-and-Turn mechanism
- Arms and Tilt-and-Turn hinges - CHIC or FUTURA
- SKG*** Burglar-proof fastening mechanism components

The combination of these components in line with variations in the sash dimensions ensures that the Giesse closing system is strong enough to be defined as burglar-proof, with RC3 classification in accordance with EN1627. System certification in accordance with EN1627, however, corresponds to the whole casement: hardware, profile, glass, wall fixings, etc.

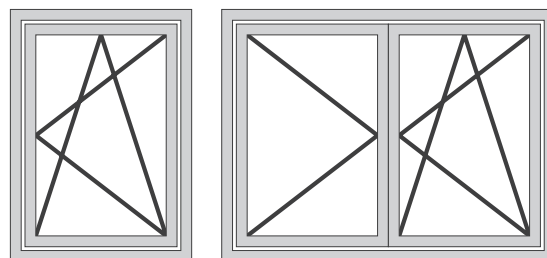

The rods used with the SKG certified closing system must be made using Aluminium.

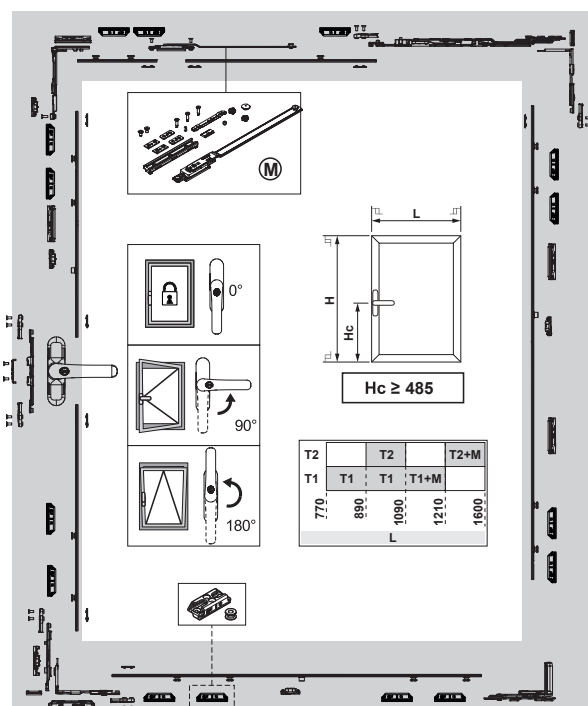
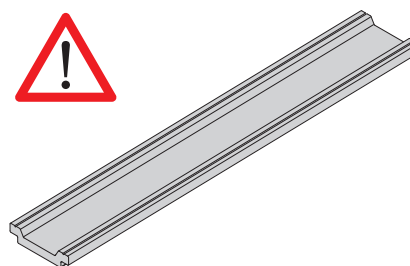

Single CHIC tilt-and-turn window - Configuration with 1000x1500 mm sash (LxH)

Quantity	Item code	Description
1	0108501 or 0119102 or 00960	Cremone
1	04007	Tilt-and-Turn window kit
15	04009	Burglar-proof fastening mechanism
1	043561 - 043562	CHIC - Tilt-and-Turn window kit, T2 arm (RH or LH)
1	04107	Incorrect movement safety device

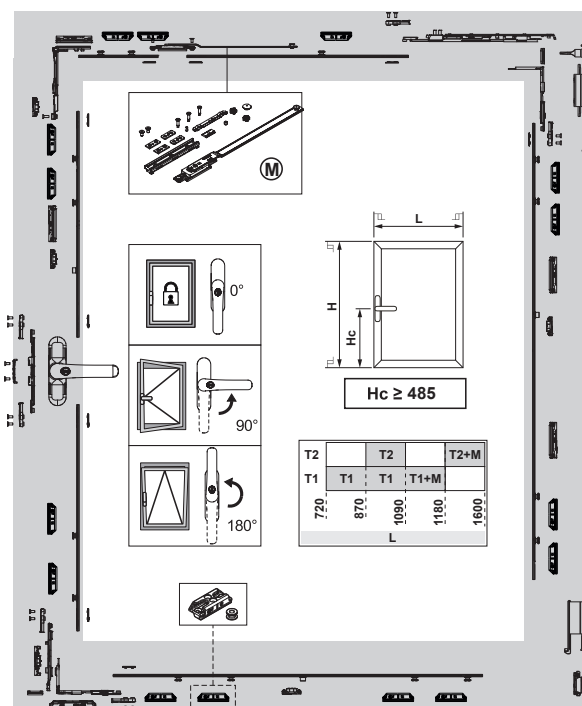

Single FUTURA tilt-and-turn window - Configuration with 1000x1500 mm sash (LxH)

Quantity	Item code	Description
1	0108501 or 0119102 or 00960	Cremone
1	04007	Tilt-and-Turn window kit
15	04009	Burglar-proof fastening mechanism
1	04285	T2 arm 130
1	04711	Tilt-and-Turn window hinge
1	04107	Incorrect movement safety device

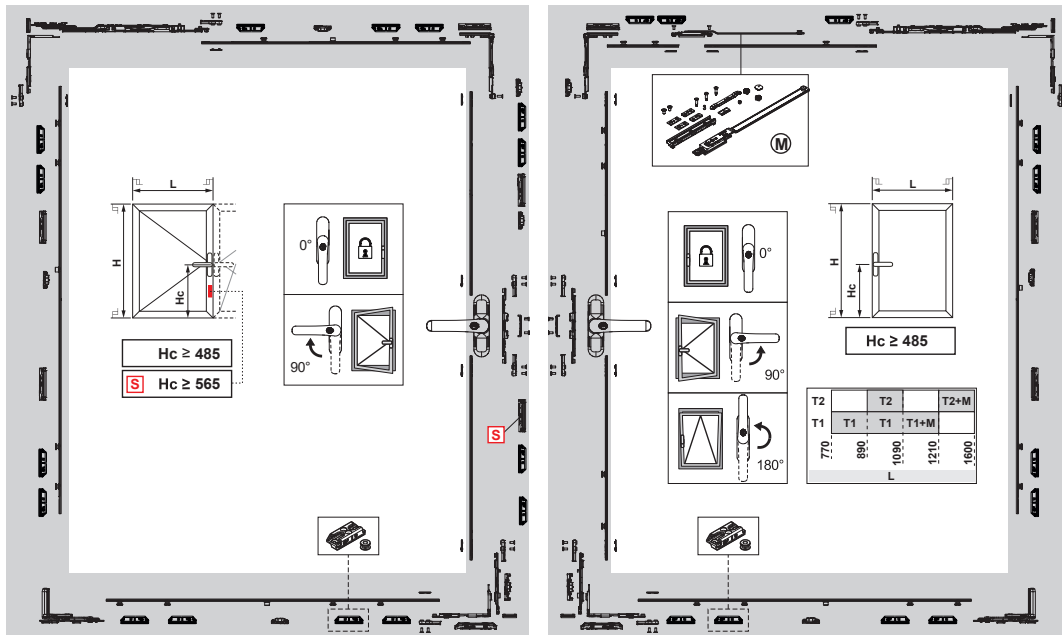

Double CHIC tilt-and-turn window - Configuration with 1000x1500 mm sash (LxH)

Quantity	Item code	Description
2	0108501 or 0119102 or 00960	Cremone
2	04007	Tilt-and-Turn window kit
26	04009	Burglar-proof fastening mechanism
1	043551/2 + 043561/2	CHIC - Tilt-and-Turn window kit, T1/T2 arm (RH or LH)
1	04107	Incorrect movement safety device

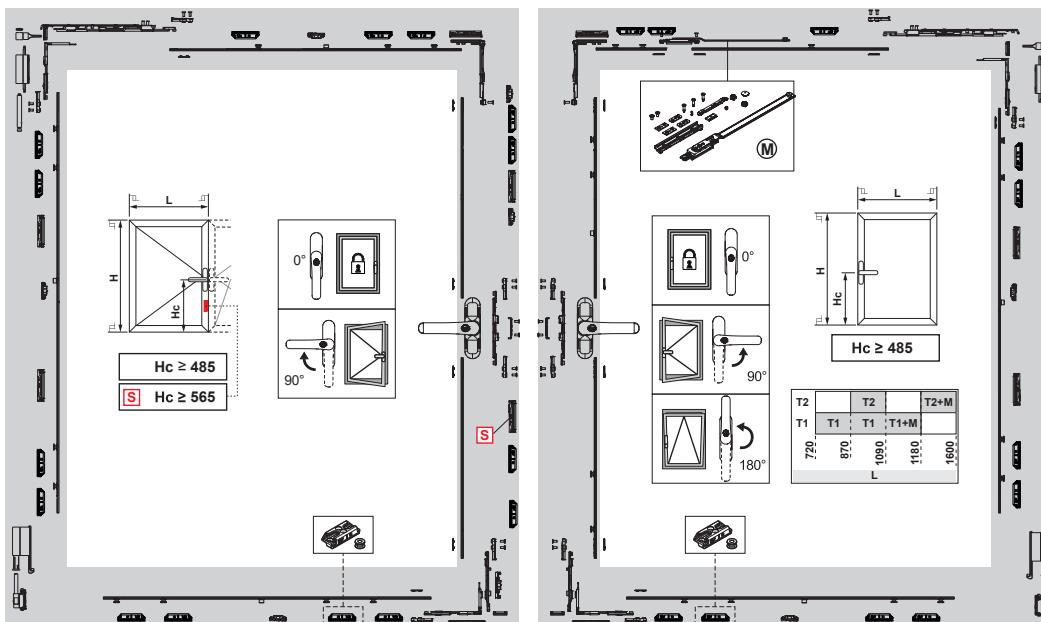

Double FUTURA tilt-and-turn window - Configuration with 1000x1500 mm sash (LxH)

Quantity	Item code	Description
2	0108501 or 0119102 or 00960	Cremone
2	04007	Tilt-and-Turn window kit
26	04009	Burglar-proof fastening mechanism
1	04284 + 04285	T1/T2 arm 130
2	04711	Tilt-and-Turn window hinge
1	04107	Incorrect movement safety device



SKG - CREMONES

Functions

Reversible cremone with key lockable handle, with rotation through 90° and 180° and opening/closing positioning notch.

Online data sheet



Technical Features

SKG*** certified, the cylinder makes it possible to lock the handle at 0° with a rotation and tear breaking strength greater than 100 Nm.

The cylinders of the FIRST KEY cremones have homogeneous coding, on request it is in any case possible to fulfill specific job orders with customized coding.

Materials

Handle in die-cast aluminium

Die-cast Zamak case, gears, racks and sliding parts

Nickel-plated brass cylinder

Internal sheath and Hostaform plate

Spring, screws and fixing plate in stainless steel

Parts

1 fixing plate

2 HSHC screws M5x14



0108501

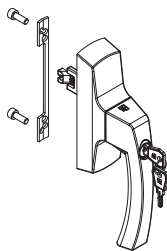

00960

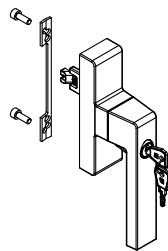

0119102

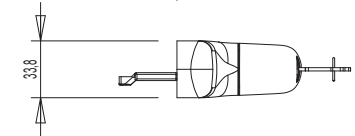
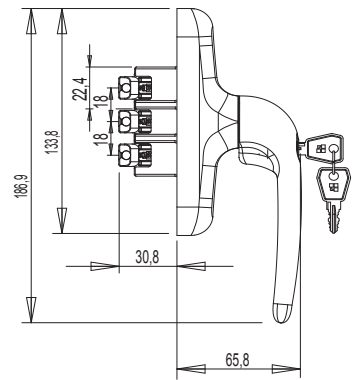
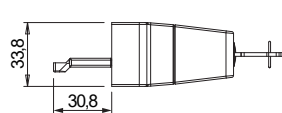
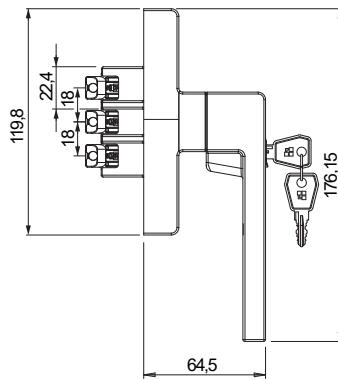
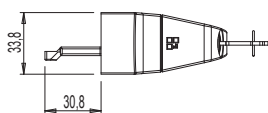
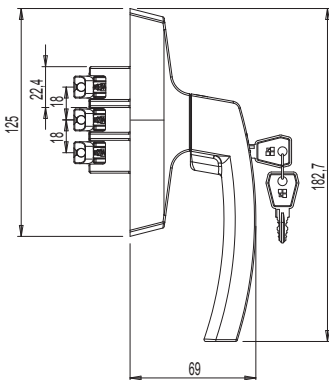
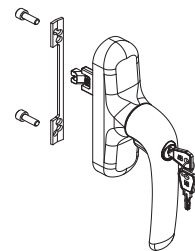

Item code	Description	Note	Base Raw	Anodised Elox	Painted	Trend/Gold Brass	Pieces per pack
0108501	SKG ASIA KEY MICRO CREMONE		X		X		5
0119102	SKG PRIMA KEY MICRO CREMONE		X		X		5
00960	SKG KORA KEY MICRO CREMONE		X		X		5

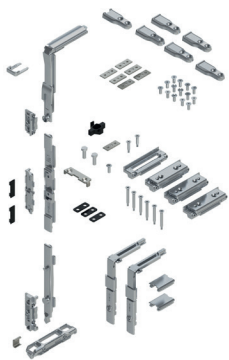

SKG - TILT-AND-TURN WINDOW KIT

Functions

Tilt-and-Turn fastening mechanism available in standard version.

[Online data sheet](#)



Technical Features

Perimetral closing: the 3 corner drives supplied allow closing on all sides. In relation to a standard product, it includes strengthening components for the joints with the rod.

4 adjustable shims reduce sideways movement of the sash, increasing its resistance to burglary.

Materials

Corner drives, drive rod, mechanism bolt tip and strikers in zamak with GS Silver Plus finish (up to 500 h of corrosion resistance)

Sash/frame shimming components in GS Silver Plus zamak

Rod strengthening components in microcast steel

Screws and grub screws in stainless steel



Rod strengthening components

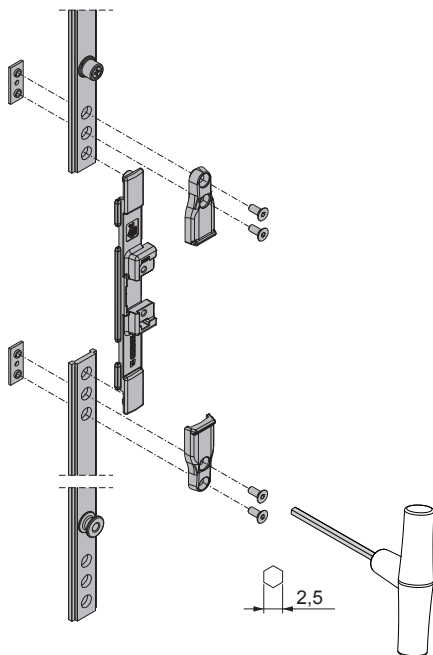

Adjustable side shims

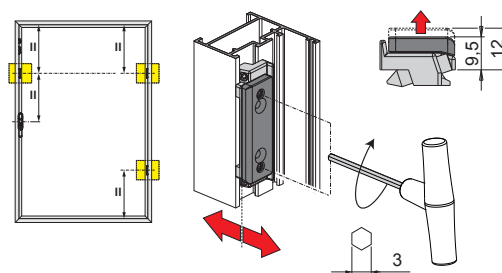

Top shim

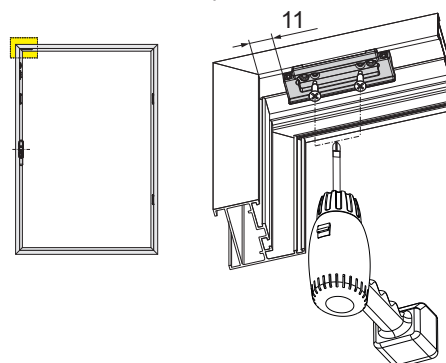

Item code	Description	Note	Base Raw	Anodised Elox	Painted	Trend/Gold Brass	Pieces per pack
04007	SKG - TILT-AND-TURN WINDOW KIT		X				5

3-STAR SKG BURGLAR-PROOF FASTENING MECHANISM



Functions

Specially designed device to increase resistance of the tilt-and-turn window to break-in attempts, making intrusion through the window more difficult.

Online data sheet



Technical Features

Article composed of two elements: the striker to be applied to the frame and the mushroom pawl to be applied to the rod.

The striker is reversible and is secured to the frame by means of the four self-threading screws that ensure precise, quick fixing to the frame.

The pawl is applied to the rod of the series by simply making a hole $\varnothing 8$ mm; thanks to this solution, using the burglar-proof kit requires no changes to the cutting.

Materials

Microcast steel striker

Pawl and screws in stainless steel.

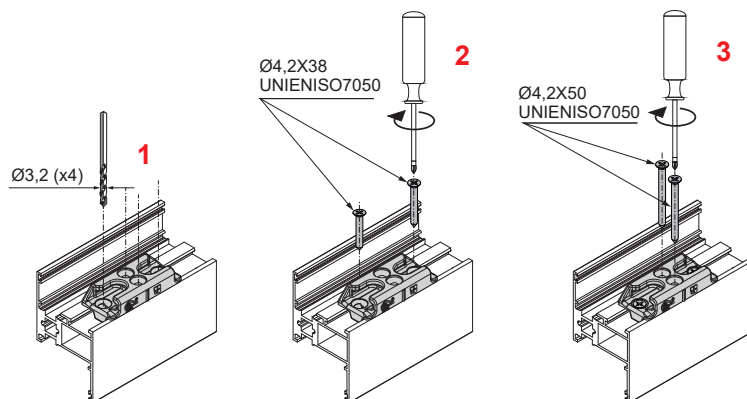
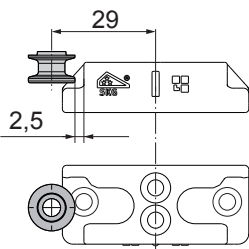
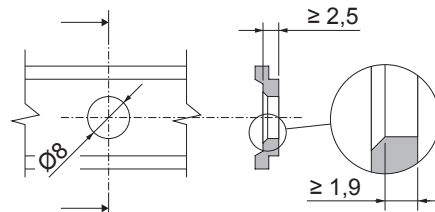
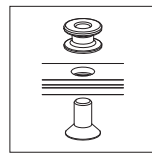
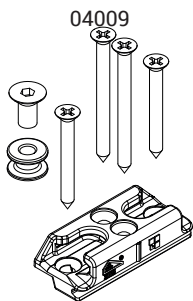

Item code	Description	Note	Base Raw	Anodised Elox	Painted	Trend/Gold Brass	Pieces per pack
04009	3-STAR SKG BURGLAR-PROOF FASTENING MECHANISM		X				20

3-STAR SKG INCORRECT MOVEMENT SAFETY DEVICE



Functions

Reinforced incorrect movement safety device

Online data sheet



Technical Features

Made of stainless steel, it protects the incorrect movement safety device slide of the cremone.

Materials

AISI 304 stainless steel components and screws.
Black polyamide shims for cremone.



04107

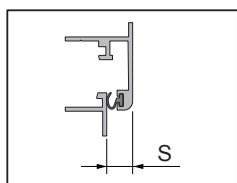
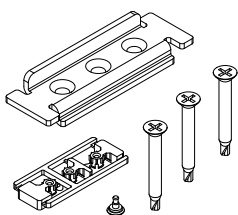

S = 13÷14mm

S = 9÷10mm

S = 11÷12mm

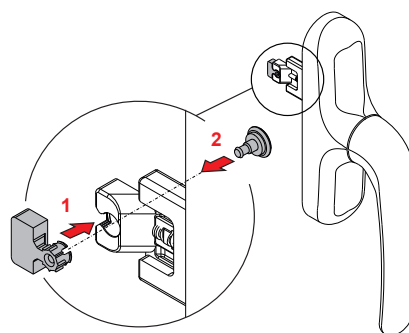
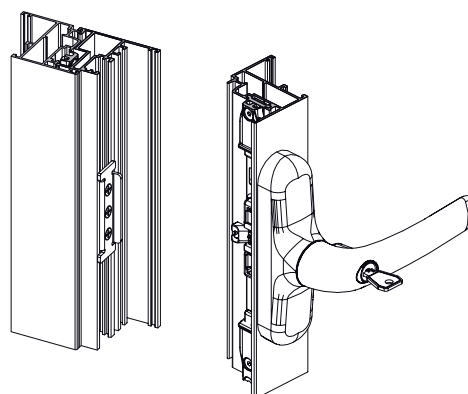
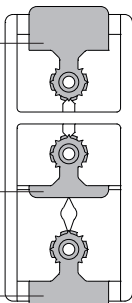

Item code	Description	Note	Base Raw	Anodised Elox	Painted	Trend/Gold Brass	Pieces per pack
04107	INCORRECT MOVEMENT SAFETY DEVICE		X				10

SKG - ADDITIONAL ARM



Functions

Additional arm for combination with the type 1 or type 2 arm on casements more than 1000 mm wide, installed to distribute the sash opening force during bottom-hung opening. Specifically reinforced to achieve SKG certification.

Online data sheet



Technical Features

The additional arm is fitted to the cross-beam on opposite side to the arm (drive side) on sashes more than 1000 mm wide to prevent excessive leverage, which might impair operation of the window, during bottom-hung opening. The arm consists of a component for connection to the corner driver without fixing screws, a rod and a slider which is fixed to the frame using three self-tapping screws provided.

The integral rod fixing utilises specific screws and plates.

Materials

- Stainless steel arm
- Slider and fixing plug in GS SILVER PLUS zamak
- Polyamide shim
- Screws and grub screws in stainless steel

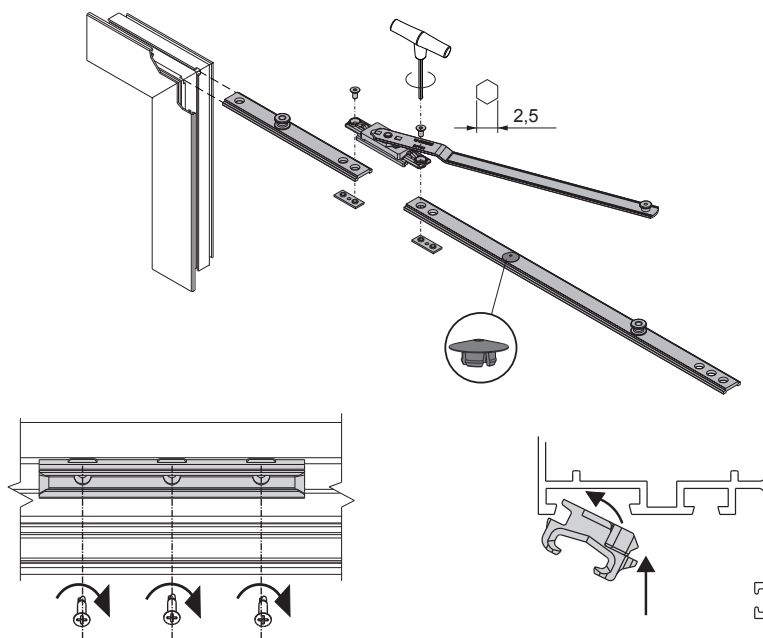
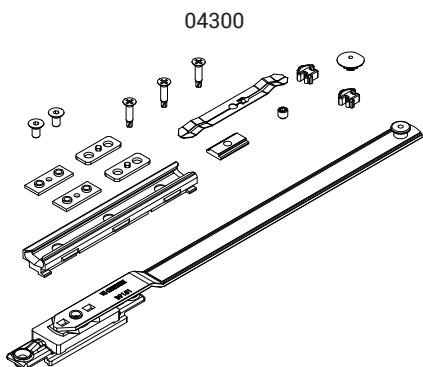
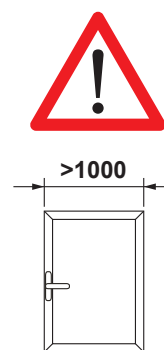

Item code	Description	Note	Base Raw	Anodised Elox	Painted	Trend/Gold Brass	Pieces per pack
04300	SKG - ADDITIONAL ARM		X				5

SKG - CHIC 100 TILT-AND-TURN HINGES AND ARMS

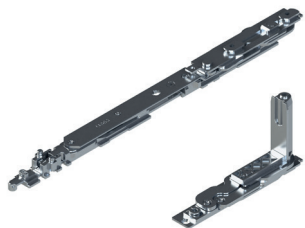

Functions

Hinge kit (upper and lower), completely pre-assembled and ready to be installed on the profile.

Online data sheet



Technical Features

They enable tilt-and-turn opening combined with the mechanisms.
Micro-ventilation and logica versions.
The arm is equipped with micro-ventilation as standard (adjustable).
Moving the fastening pawl takes the arm from conventional to logica.
The T2 arm is adjustable: the opening "A" goes from 178 mm (base) to 148 mm.

Materials

Corner support made of zamak
Connecting brackets and hinge plates made of zinc plated steel
Pins made of 304 grade stainless steel and aluminium bronze
Cams made of zinc plated steel
Connecting bracket and arm rod made of 304 grade stainless steel

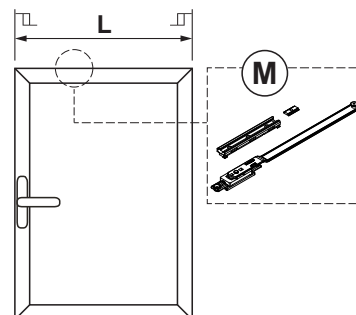

T2		T2		T2+M
T1	T1	T1	T1+M	
770	890	1090	1210	1600
L				

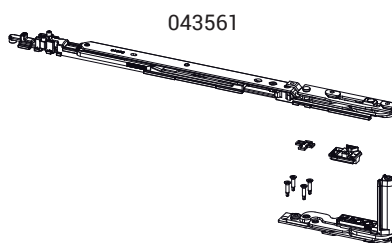
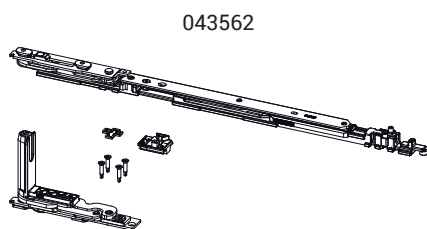
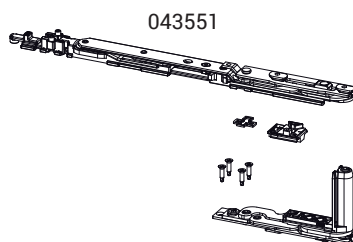
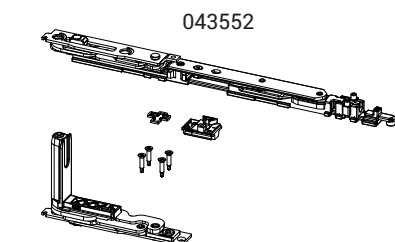

Sash opening



Item code	Description	PROFILE CROSS - SECTION	A (mm)	Hand	Base Raw	Anodised Elox	Painted	Trend/Gold Brass	Pieces per pack
043551	CHIC - T1 ARM T&T KIT	C001-C002-C003-C005-C006	98	RX	X				10
043552	CHIC - T1 ARM T&T KIT	C001-C002-C003-C005-C006	98	LX	X				10
043561	CHIC - T2 ARM T&T KIT	C001-C002-C003-C005-C006	148÷178	RX	X				10
043562	CHIC - T2 ARM T&T KIT	C001-C002-C003-C005-C006	148÷178	LX	X				10

SKG - CHIC 130 TILT-AND-TURN HINGES AND ARMS

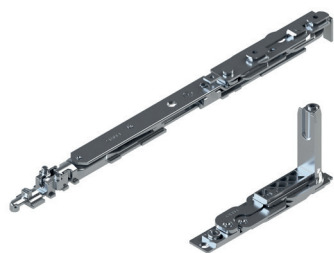

Functions

Set of hinges (top and bottom), completely pre-assembled and ready to be installed on the profile.

Online data sheet



Technical Features

They enable tilt-and-turn opening combined with the mechanisms.
 Micro-ventilation and logica versions.
 The arm is equipped with micro-ventilation as standard (adjustable).
 Moving the fastening pawl takes the arm from conventional to logica.
 The T2 arm is adjustable: the opening "A" goes from 178 mm (base) to 148 mm.

Materials

Corner support made of zamak
 Connecting brackets and hinge plates made of zinc plated steel
 Pins made of 304 grade stainless steel and aluminium bronze
 Cams made of zinc plated steel
 Connecting bracket and arm rod made of 304 grade stainless steel

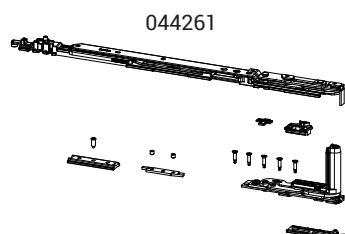
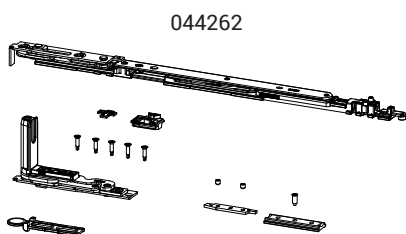
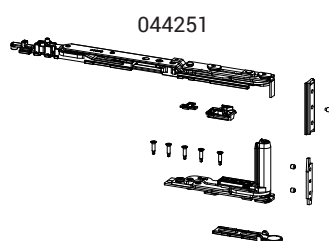
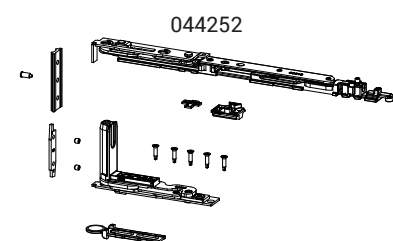
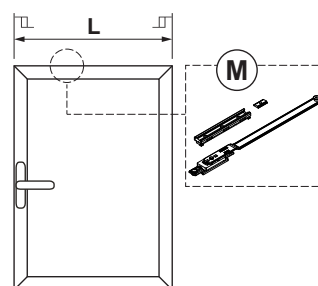

T2		T2		T2+M
T1	T1	T1	T1+M	
770	890	1090	1210	1600
L				

Sash opening

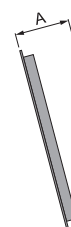

Item code	Description	PROFILE CROSS - SECTION	A (mm)	Hand	Base Raw	Anodised Elox	Painted	Trend/Gold Brass	Pieces per pack
044251	CHIC - T1 ARM T&T KIT	C001	98	RX	X				10
044252	CHIC - T1 ARM T&T KIT	C001	98	LX	X				10
044261	CHIC - T2 ARM T&T KIT	C001	148÷178	RX	X				10
044262	CHIC - T2 ARM T&T KIT	C001	148÷178	LX	X				10

SKG - FUTURA 3D 130 HINGES AND ARMS



Functions

Futura 3D 130 tilt-and-turn hinge set (upper and lower) and arm.

Online data sheet



Technical Features

Hinges: hinge set (upper and lower), completely pre-assembled and ready to be installed on the profile.

Arms: allow tilt-and-turn opening in conjunction with tilt-and-turn hinges and mechanisms.

Materials

Hinges:

- Body of hinges in extruded aluminium and brass
- Supports in zamak with GS Silver Plus finish (up to 500 h corrosion resistance)
- Pins, screws and grub screws in stainless steel

Arms:

- Body, fixing block and slider in zamak with GS Silver Plus finish (up to 500 h corrosion resistance)
- Rod, connecting bracket, grub screws and screws in stainless steel
- Stop disk in polyamide

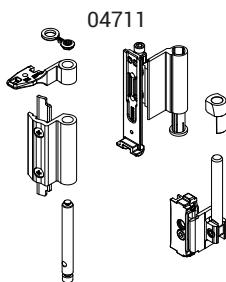
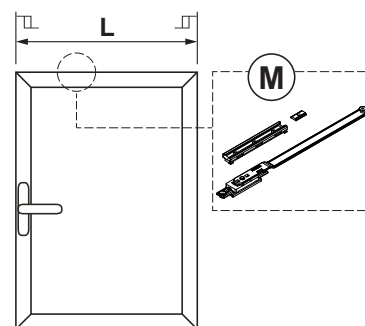

04284

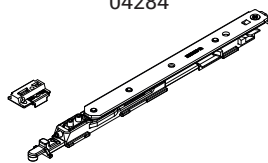

04285

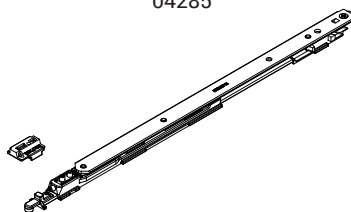

T2		T2		T2+M
T1	T1	T1	T1+M	
720	870	1090	1180	1600
L				

Sash opening



Item code	Description	PROFILE CROSS - SECTION	Base Raw	Anodised Elox	Painted	Trend/Gold Brass	Pieces per pack
04711	HINGE T/T FUTURA 130	C001-C002-C003-C005-C006	X		X	X	10

Item code	Description	PROFILE CROSS - SECTION	A (mm)	Base Raw	Anodised Elox	Painted	Trend/Gold Brass	Pieces per pack
04284	ARM T1 130 WITH MICROVENTILATION	C001-C002-C003-C015-C016-C017	120					10
04285	ARM T2 130 WITH MICROVENTILATION	C001-C002-C003-C015-C016-C017	175					10

3-STAR SKG - SIDE-HUNG SYSTEMS

Functions

Giesse offers for single and double sash windows a complete burglar-proof closing system with SKG*** certification issued by IKOB SKG (Netherlands). The use of premium materials (such as microcast steel) is essential for strengthening the components and connection devices and ensures the closing system is designed to withstand attempted burglaries and direct attacks.

Technical Features

As it is a system which requires locking points on all sides, the tilt-and-turn arms must be used to allow the application of burglar-proof fastening mechanisms to the hinge side.

The SKG*** system consists of:

- Mechanism - SKG*** Cremone with key
- SKG*** Side-Hung mechanism
- Arms and TILT-AND-TURN hinges - CHIC or FUTURA
- SKG*** Burglar-proof fastening mechanism components

The combination of these components in line with variations in the sash dimensions ensures that the Giesse closing system is strong enough to be defined as burglar-proof, with RC3 classification in accordance with EN1627. System certification in accordance with EN1627, however, corresponds to the whole casement: hardware, profile, glass, wall fixings, etc.

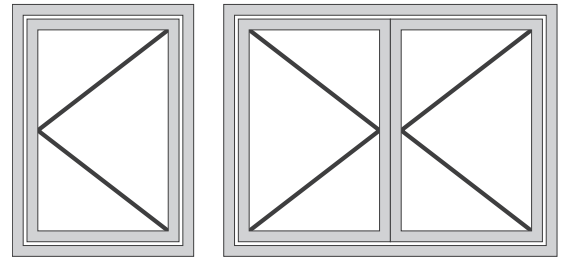

The rods used with the SKG certified closing system must be made using Aluminium.

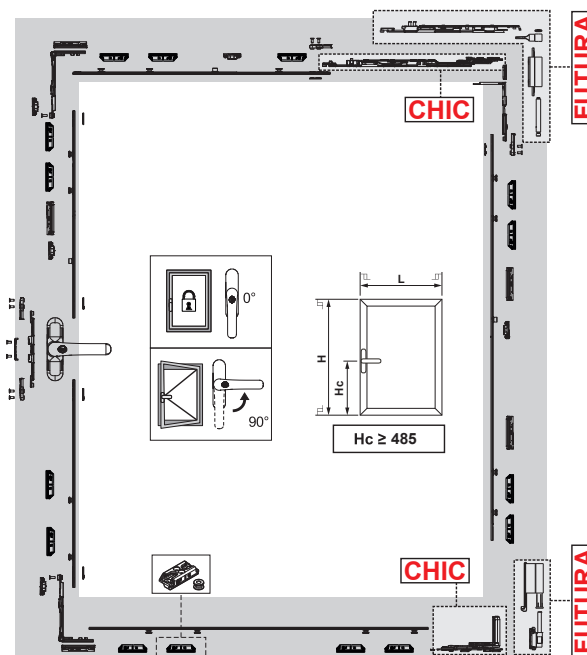
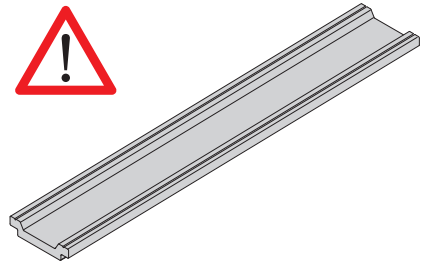

Single CHIC side-hung window - Configuration with 1000x1500 mm sash (LxH)

Quantity	Item code	Description
1	0108501 or 0119102 or 00960	Cremone
1	04005	Side-Hung window kit
15	04009	Burglar-proof fastening mechanism
1	043561 - 043562	CHIC - Tilt-and-Turn window kit, T2 arm (RH or LH)
1	04107	Incorrect movement safety device

Single FUTURA side-hung window - Configuration with 1000x1500 mm sash (LxH)

Quantity	Item code	Description
1	0108501 or 0119102 or 00960	Cremone
1	04005	Side-Hung window kit
15	04009	Burglar-proof fastening mechanism
1	04285	T2 arm 130
1	04711	Tilt-and-Turn window hinge
1	04107	Incorrect movement safety device

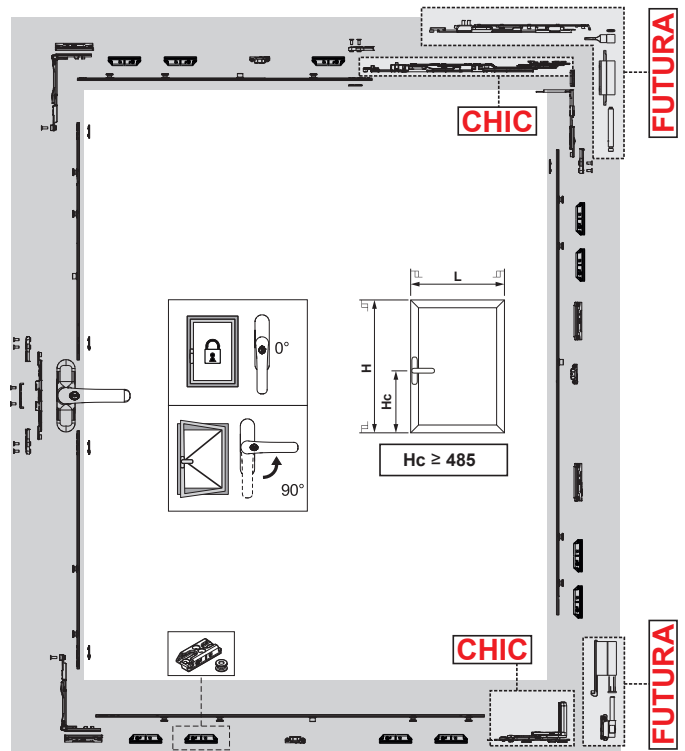
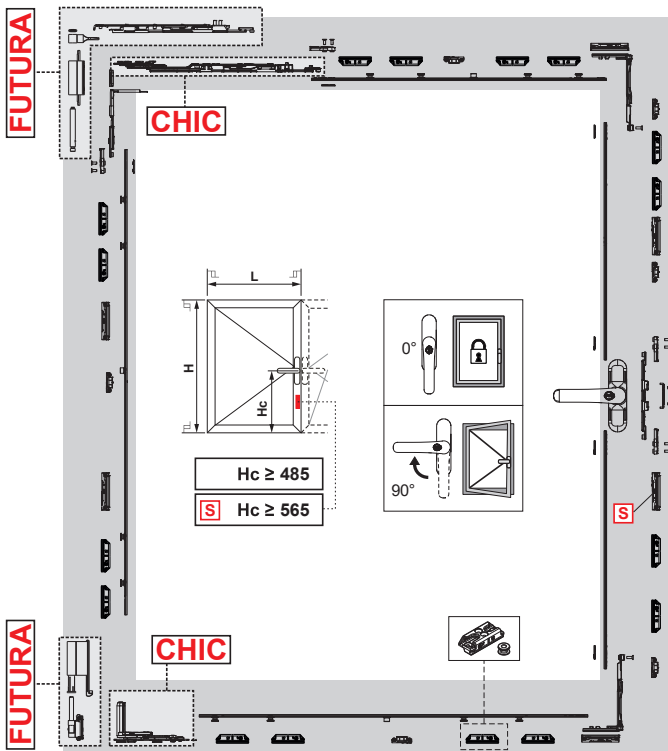

Double CHIC side-hung window - Configuration with 1000x1500 mm sash (LxH)

Quantity	Item code	Description
2	0108501 or 0119102 or 00960	Cremone
2	04005	Side-Hung window kit
26	04009	Burglar-proof fastening mechanism
2	043561 or 043562	CHIC - Tilt-and-Turn window kit, T2 arm (RH or LH)
1	04107	Incorrect movement safety device

Double FUTURA side-hung window - Configuration with 1000x1500 mm sash (LxH)

Quantity	Item code	Description
2	0108501 or 0119102 or 00960	Cremone
2	04005	Side-Hung window kit
26	04009	Burglar-proof fastening mechanism
2	04285	T2 arm 130
2	04711	Tilt-and-Turn window hinge
1	04107	Incorrect movement safety device



SKG - CREMONES

Functions

Reversible cremone with key lockable handle, with rotation through 90° and 180° and opening/closing positioning notch.

Online data sheet



Technical Features

SKG*** certified, the cylinder makes it possible to lock the handle at 0° with a rotation and tear breaking strength greater than 100 Nm.

The cylinders of the FIRST KEY cremones have homogeneous coding, on request it is in any case possible to fulfill specific job orders with customized coding.

Materials

Handle in die-cast aluminium

Die-cast Zamak case, gears, racks and sliding parts

Nickel-plated brass cylinder

Internal sheath and Hostaform plate

Spring, screws and fixing plate in stainless steel

Parts

1 fixing plate

2 HSHC screws M5x14



0108501

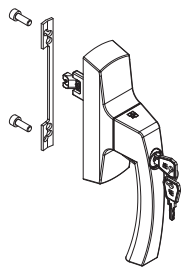

00960

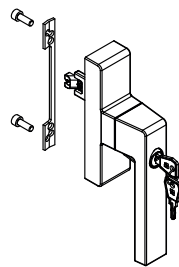

0119102

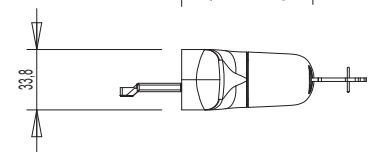
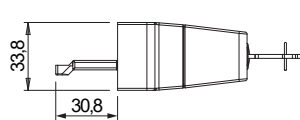
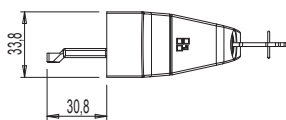
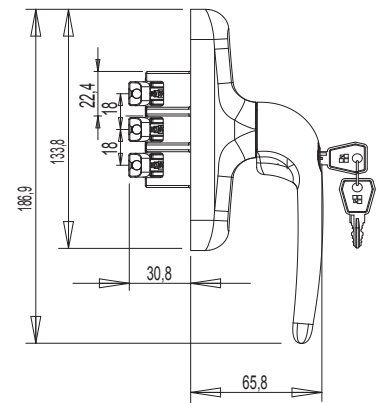
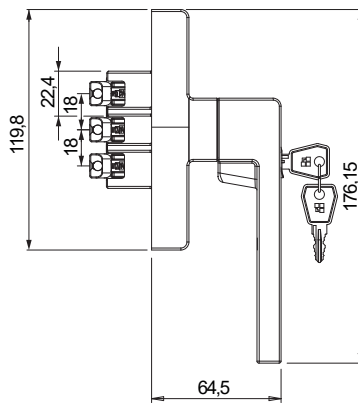
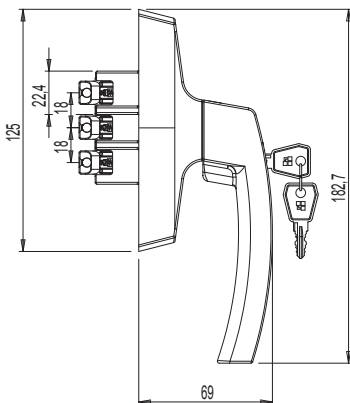
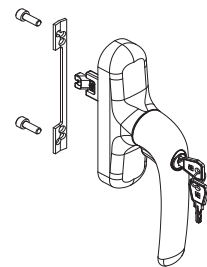

Item code	Description	Note	Base Raw	Anodised Elox	Painted	Trend/Gold Brass	Pieces per pack
0108501	SKG ASIA KEY MICRO CREMONE		X		X		5
0119102	SKG PRIMA KEY MICRO CREMONE		X		X		5
00960	SKG KORA KEY MICRO CREMONE		X		X		5

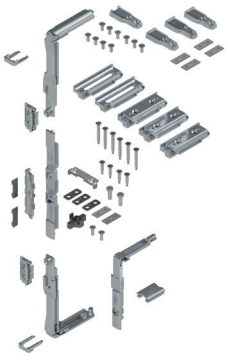

SKG - SIDE-HUNG WINDOW KIT

Functions

Side-Hung fastening mechanisms.

Online data sheet



Technical Features

Perimetral closing: the 3 corner drives supplied allow closing on all sides. In relation to a standard product, it includes strengthening components for the joints with the rod.

4 adjustable shims reduce sideways movement of the sash, increasing its resistance to burglary.

Materials

Corner drives, drive rod, mechanism bolt tip and strikers in zamak with GS Silver Plus finish (up to 500 h of corrosion resistance)

Sash/frame shimming components in GS Silver Plus zamak

Rod strengthening components in microcast steel

Screws and grub screws in stainless steel



Rod strengthening components

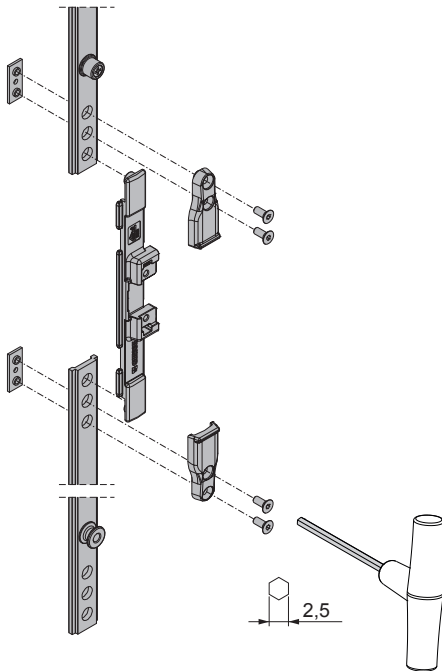

Adjustable side shims

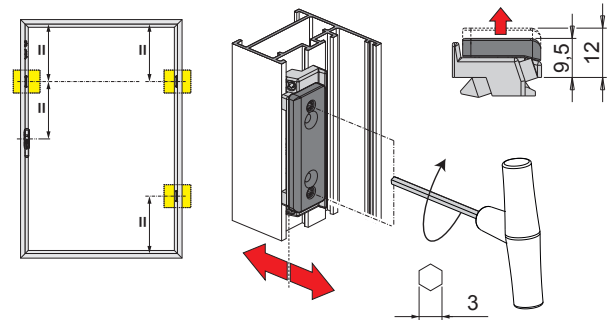

Top shim

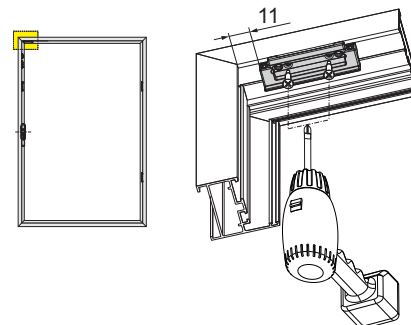

Item code	Description	Note	Base Raw	Anodised Elox	Painted	Trend/Gold Brass	Pieces per pack
04005	SKG - SIDE-HUNG KIT		X				5

3-STAR SKG BURGLAR-PROOF FASTENING MECHANISM



Functions

Specially designed device to increase resistance of the tilt-and-turn window to break-in attempts, making intrusion through the window more difficult.

Online data sheet



Technical Features

Article composed of two elements: the striker to be applied to the frame and the mushroom pawl to be applied to the rod.

The striker is reversible and is secured to the frame by means of the four self-threading screws that ensure precise, quick fixing to the frame.

The pawl is applied to the rod of the series by simply making a hole $\varnothing 8$ mm; thanks to this solution, using the burglar-proof kit requires no changes to the cutting.

Materials

Microcast steel striker
Pawl and screws in stainless steel.

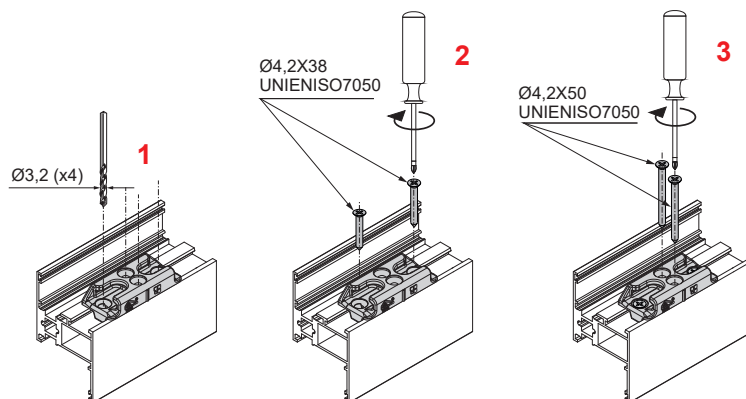
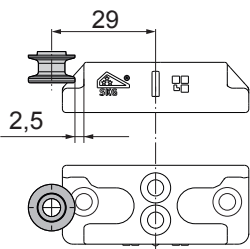
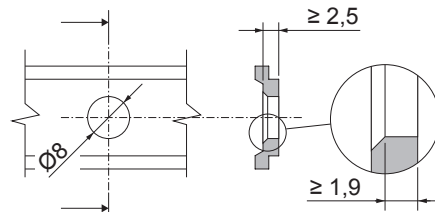
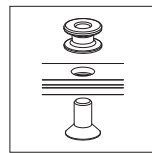
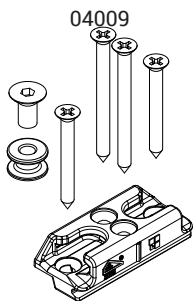

Item code	Description	Note	Base Raw	Anodised Elox	Painted	Trend/Gold Brass	Pieces per pack
04009	3-STAR SKG BURGLAR-PROOF FASTENING MECHANISM		X				20

3-STAR SKG INCORRECT MOVEMENT SAFETY DEVICE

Functions

Reinforced incorrect movement safety device

Online data sheet



Technical Features

Made of stainless steel, it protects the incorrect movement safety device slide of the cremone.

Materials

AISI 304 stainless steel components and screws.
Black polyamide shims for cremone.



04107

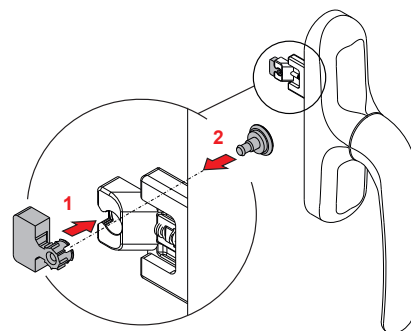
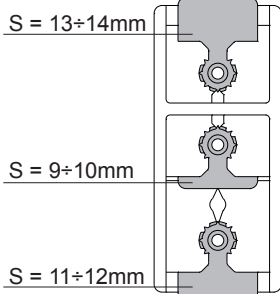
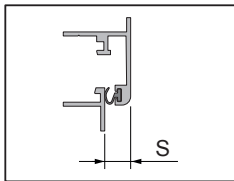
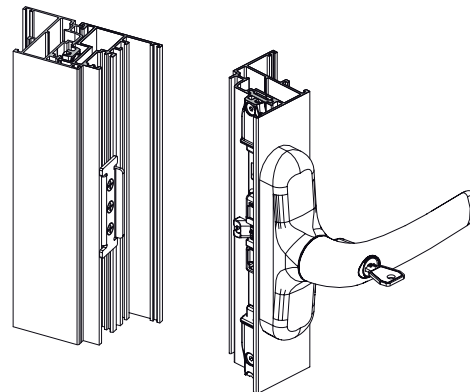
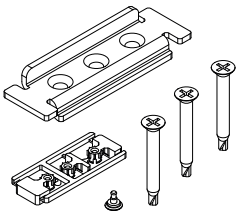

Item code	Description	Note	Base Raw	Anodised Elox	Painted	Trend/Gold Brass	Pieces per pack
04107	INCORRECT MOVEMENT SAFETY DEVICE		X				10

SKG - CHIC 100 SIDE-HUNG HINGES AND ARMS

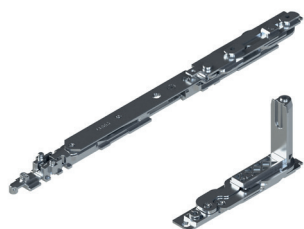

Functions

Set of hinges (top and bottom) for side-hung or secondary sash with tilt-and-turn CHIC 3D 100.

Online data sheet



Technical Features

Sash opening to 180°.

Maximum load capacity 100 kg.

Assembly is simple, fast and easy using the special pre-assembled cams.

When there is an additional fastening mechanism, you need to use the CHIC fastening element.

Both hinges are adjustable (3D).

If opening is obstructed, you need to use the FRIZ limitation arm.

CAUTION: This hinge is designed to be used only on inward opening casements and is not suitable for outward opening casements.

Materials

Corner support made of zamak

Connecting brackets and hinge plates made of zinc plated steel

Pins made of 304 grade stainless steel and aluminium bronze

Cams made of zinc plated steel

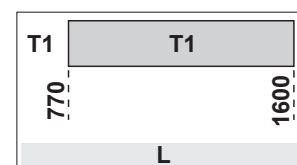
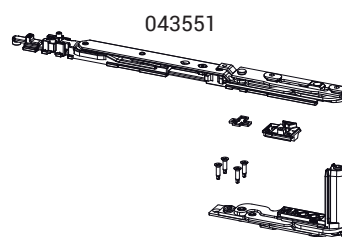
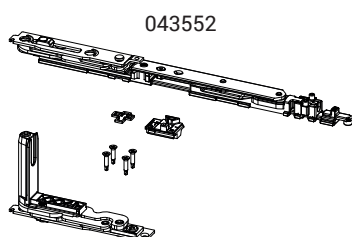
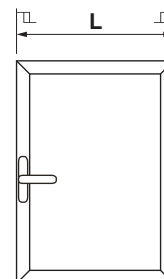

Sash opening

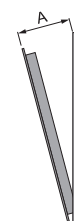

Item code	Description	PROFILE CROSS - SECTION	A (mm)	Hand	Base Raw	Anodised Elox	Painted	Trend/Gold Brass	Pieces per pack
043551	CHIC - T1 ARM T&T KIT	C001-C002-C003-C005-C006	98	RX	X				10
043552	CHIC - T1 ARM T&T KIT	C001-C002-C003-C005-C006	98	LX	X				10

SKG - CHIC 130 SIDE-HUNG HINGES AND ARMS

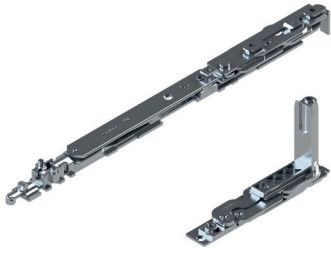

Functions

Set of hinges (top and bottom) for side-hung or secondary sash with tilt-and-turn CHIC 3D 130.

Online data sheet



Technical Features

Sash opening to 180°.
 Maximum load capacity 130 kg.
 Assembly is simple, fast and easy using the special pre-assembled cams.
 When there is an additional fastening mechanism, you need to use the CHIC fastening element.
 Both hinges are adjustable (3D).
 If opening is obstructed, you need to use the FRIZ limitation arm.
CAUTION: This hinge is designed to be used only on inward opening casements and is not suitable for outward opening casements.

Materials

Corner support made of zamak
 Connecting brackets and hinge plates made of zinc plated steel
 Pins made of 304 grade stainless steel and aluminium bronze
 Cams made of zinc plated steel

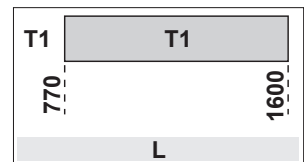
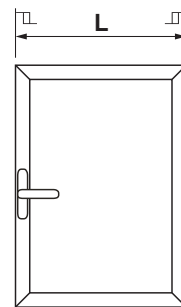

Sash opening

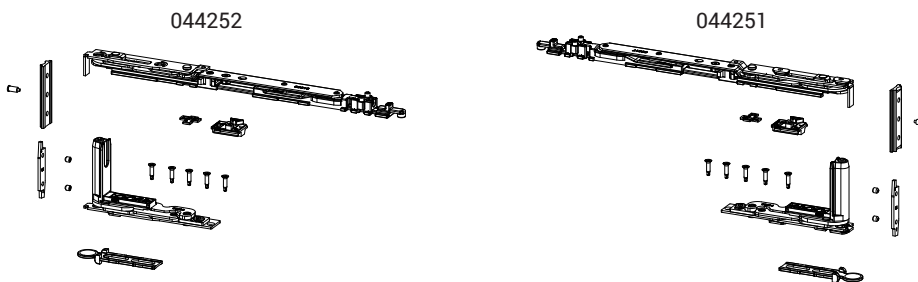
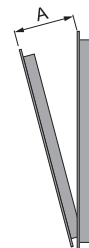

Item code	Description	PROFILE CROSS - SECTION	A (mm)	Hand	Base Raw	Anodised Elox	Painted	Trend/Gold Brass	Pieces per pack
044251	CHIC - T1 ARM T&T KIT	C001	98	RX	X				10
044252	CHIC - T1 ARM T&T KIT	C001	98	LX	X				10

SKG - FUTURA 3D 130 HINGES AND ARMS



Functions

Futura 3D 130 tilt-and-turn hinge set (upper and lower) and arm.

Online data sheet



Technical Features

Hinges: hinge set (upper and lower), completely pre-assembled and ready to be installed on the profile.

Arms: allow tilt-and-turn opening in conjunction with tilt-and-turn hinges and mechanisms.

Materials

Hinges:

- Body of hinges in extruded aluminium and brass
- Supports in zamak with GS Silver Plus finish (up to 500 h corrosion resistance)
- Pins, screws and grub screws in stainless steel

Arms:

- Body, fixing block and slider in zamak with GS Silver Plus finish (up to 500 h corrosion resistance)
- Rod, connecting bracket, grub screws and screws in stainless steel
- Stop disk in polyamide

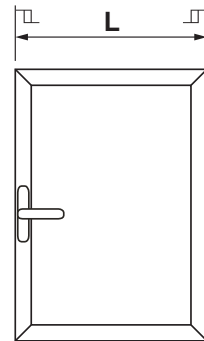

04711

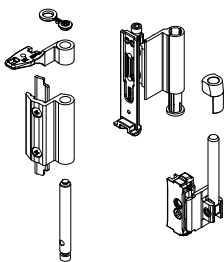

04284

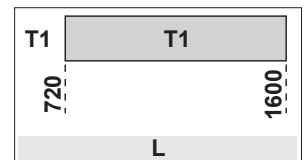
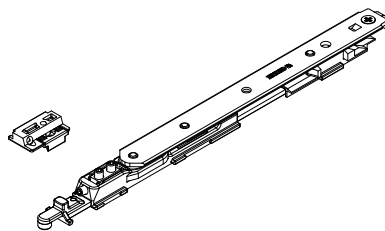

Sash opening

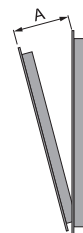

Item code	Description	PROFILE CROSS - SECTION	Base Raw	Anodised Elox	Painted	Trend/Gold Brass	Pieces per pack
04711	HINGE T/T FUTURA 130	C001-C002-C003-C005-C006	X		X	X	10

Item code	Description	PROFILE CROSS - SECTION	A (mm)	Base Raw	Anodised Elox	Painted	Trend/Gold Brass	Pieces per pack
04284	ARM T1 130 WITH MICROVENTILATION	C001-C002-C003-C015-C016-C017	120					10

SECURITY SASH

SECURITY SASH

Functions

The Security Sash is a piece of hardware for making security side-hung case-ments.

Technical Features

The Security Sash hardware permits limited opening of the sash, depending on the arm adjustment, with the cremone turned through 90° (see table) and fully opened with the cremone turned through 180°.

It is available in two versions depending on the position of the arms that can be with horizontal or vertical closing.

Operation:

- 0° mechanism - closed sash
- 90° mechanism - open sash (limited)
- 180° mechanism - fully open sash

Making a Security Sash requires:

- Security Sash Kit (horizontal or vertical)
- Sash hinges (CHIC 100, CHIC 130, FLASH BASE, BRIDGE 2, CELERA, FULCRA, FLASH XXL)
- Key Capture Cremone
- Additional fastening mechanisms



VERTICAL SECURITY SASH

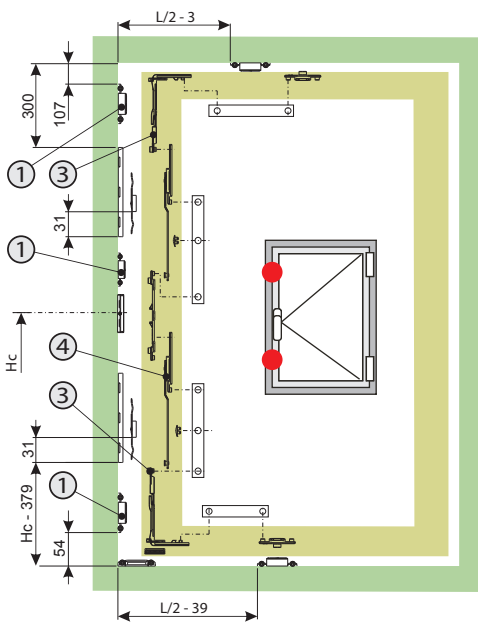

HORIZONTAL SECURITY SASH

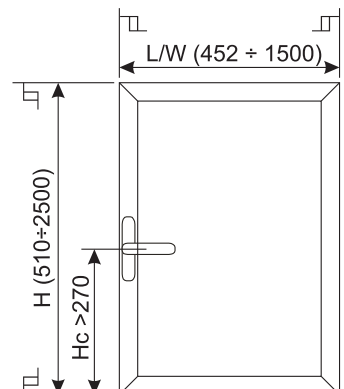
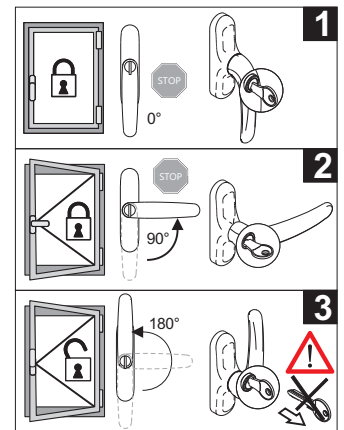
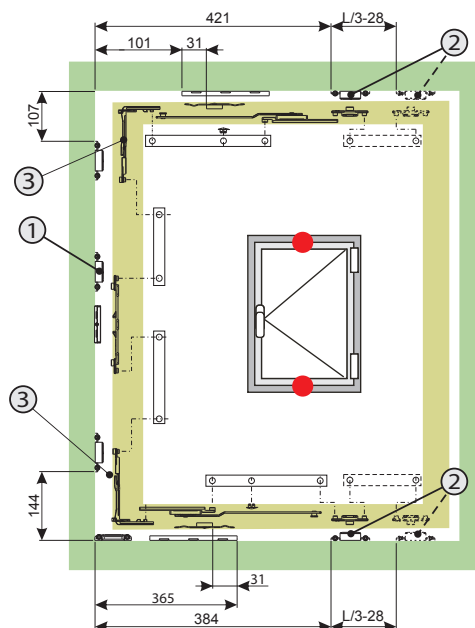



SECURITY SASH KIT

Functions

The Security Sash hardware kit permits limited opening of the sash, depending on the arm adjustment, with the cremone turned through 90° and fully opened with the cremone turned through 180°.

Online data sheet



Technical Features

The kit is available in two versions depending on the position of the arms that can be with horizontal or vertical closing.

The Key Capture cremone and the CHIC 100, CHIC 130, FLASH BASE, BRIDGE 2, CELERA, FULCRA, FLASH XXL type hinges must be added to the kit, depending on the size and capacity of the casement.

Using Key mechanisms you can inhibit full opening of the sash, retaining only the emergency exit.

Materials

Strikers, connection elements, incorrect movement striker, drive rod, slider, stop plate, drives and clips in zamak with GS Silver Plus finish (up to 500 h of corrosion resistance).

Striker and lifting element, incorrect movement safety device shims, adjustment shims and supporting plug in polyamide.

Screws, grub screws, additional arm and spring for arm in stainless steel.

VERTICAL SECURITY SASH KIT

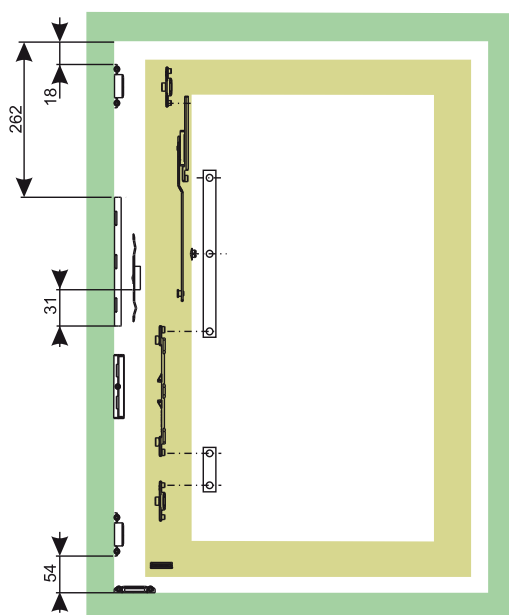

HORIZONTAL SECURITY SASH KIT

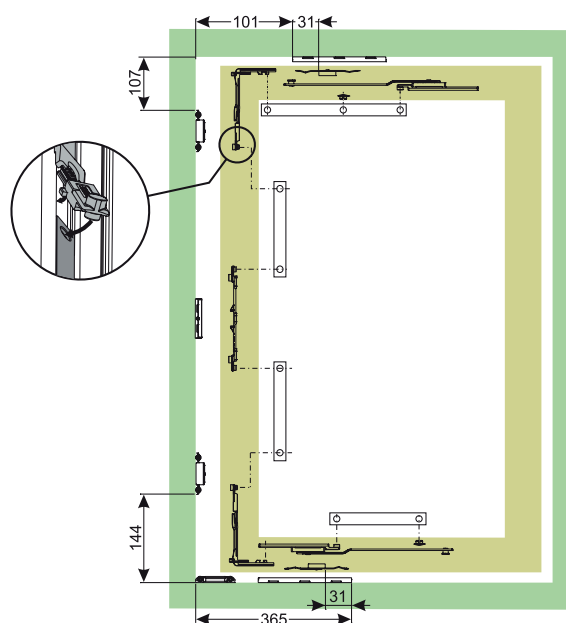

SECURITY SASH

01174K

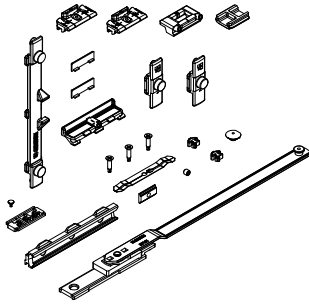

01175K

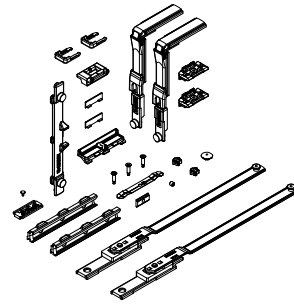

01207

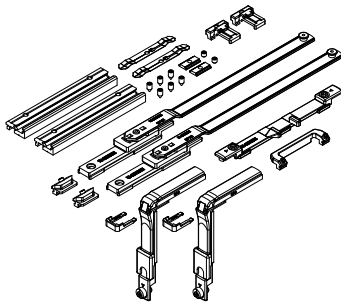

01210

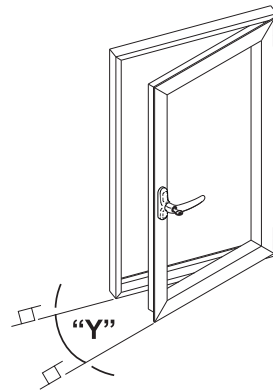
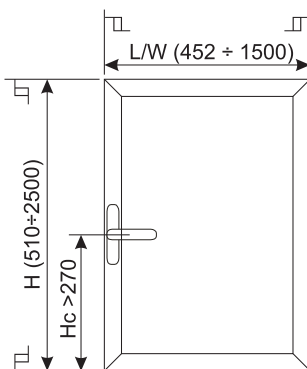
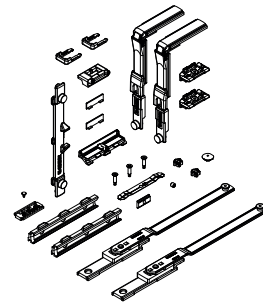

Item code	Description	PROFILE CROSS - SECTION	Sash range [mm]	Y [mm] Limited sash opening	Base Raw	Anodised Elox	Painted	Trend/Gold Brass	Pieces per pack
01174K	FUTURA VERTICAL SECURITY SASH MECHANISM	C001-C002-C003-C004-C005-C006	W 800 ÷ 1500 H 650 ÷ 2500	110÷140	X				10
01175K	FUTURA HORIZONTAL SECURITY SASH MECHANISM	C001-C002-C003-C004-C005-C006	W 452 ÷ 1500 H 510 ÷ 2500	130÷260	X				10
01207	FUTURA HORIZONTAL SECURITY SASH MECHANISM	C007	L 480 ÷ 1500 H 510 ÷ 2500	130÷260	X				10
01210	FUTURA HORIZONTAL SECURITY SASH MECHANISM	C001-C002-C003-C005	L 397 ÷ 1500 H 510 ÷ 2500	92÷152	X				10



SECURITY SASH CREMONE

Functions

The Giesse Key Capture cremones are decisive for the operation of the Security Sash.

Online data sheet



Technical Features

Operation:

- 0° mechanism - closed sash
- 90° mechanism - open sash (limited)
- 180° mechanism - fully open sash

The cylinder has the Giesse Key Capture system.

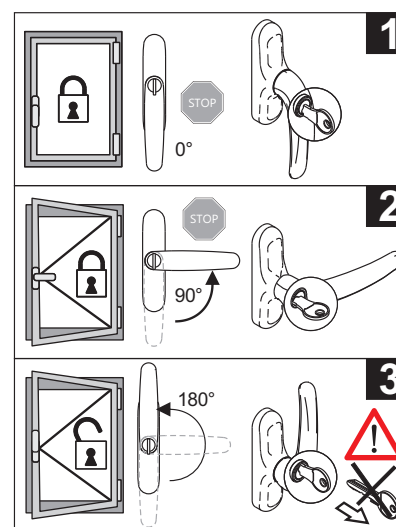
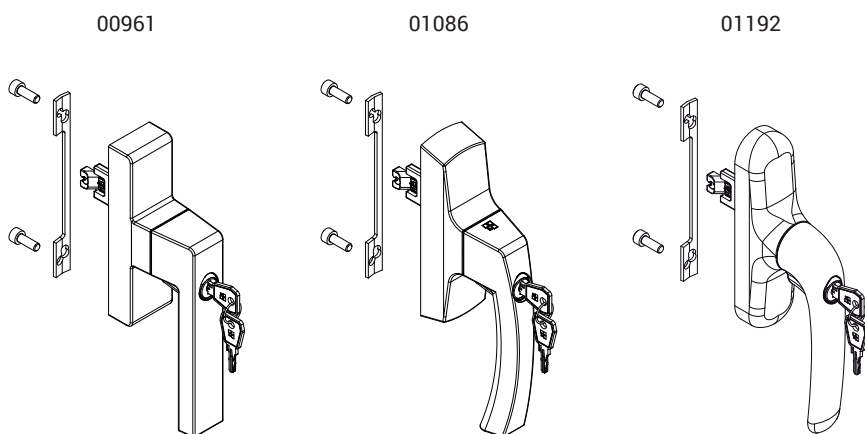

Item code	Description	PROFILE CROSS - SECTION	C/C distances	Operation	Base Raw	Anodised Elox	Painted	Trend/Gold Brass	Pieces per pack
00961	KORA KEY T/T CREMONE LGC	C001-C002-C003-C004-C005-C006-C007-C008-C009-C010-C012-C013-C014-C015-C016-C017	104 - 92	one-way	X		X	X	5
01086	ASIA KEY CAPTURE LGC CREMONE	C001-C002-C003-C004-C005-C006-C007-C012-C013-C014-C015-C016-C017	104 - 92	one-way	X		X		5
01192	PRIMA KEY CAPTURE LGC CREMONE	C001-C002-C003-C004-C005-C006-C007-C010-C012-C013-C014-C014-C015-C016-C017	104 - 92	one-way	X		X		5



SECURITY SASH HINGES

Functions

According to the need for visible or concealed hinges and the required load capacities, any Giesse sash hinge can be used.

Online data sheet



00120U

00600N

00681

00700

043541

044241

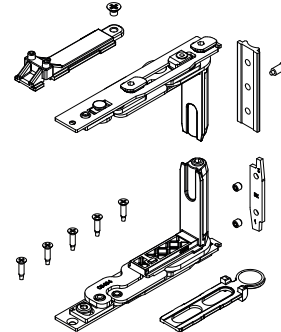
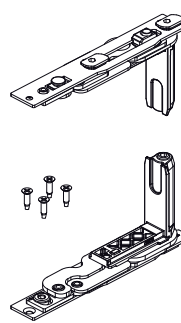
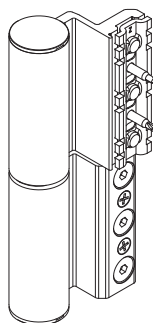
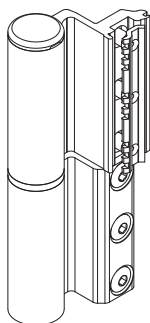
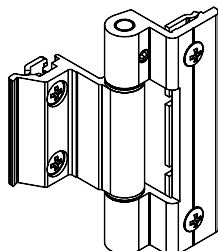
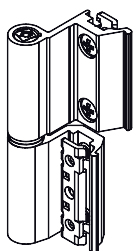

Item code	Description	PROFILE CROSS - SECTION	Hand	Load capacity 2 hinges [kg]	Load capacity 3 hinges [kg]	Base Raw	Anodised Elox	Painted	Trend/Gold Brass	Pieces per pack
00120U	FLASH BASE HINGE	C001		75	85	X	X	X	X	20
00128U	FLASH BASE HINGE	C007		75	85	X	X	X	X	20
00598N	HINGE FOR FLASH XXL DOORS	C001		160	180		X			20
00599	COVER, FLASH XXL HINGE	C001		-	-	X	X	X	X	20
00600N	BRIDGE 2 HINGE	C001-C002		90	100	X	X	X	X	20
00602N	BRIDGE 2 HINGE	C007		90	100	X	X	X	X	20
00681	CELERA HINGE	C001 - C002 - C005		100	120	X	X	X	X	20
00682	CELERA HINGE	C007		100	120	X	X	X	X	20
00700	FULCRA HINGE EURO GROOVE	C001		120	150	X	X	X	X	10
00701	FULCRA HINGE R40	C007-C008		120	150	X	X	X	X	10
043541	CHIC - SASH HINGE SET	C001-C002-C003-C005-C006	RX	100	-	X				10
043542	CHIC - SASH HINGE SET	C001-C002-C003-C005-C006	LX	100	-	X				10
044241	CHIC - SASH HINGE SET	C001	RX	130	-	X				10
044242	CHIC - SASH HINGE SET	C001	LX	130	-	X				10

SECURITY SASH ADDITIONAL FASTENING MECHANISMS

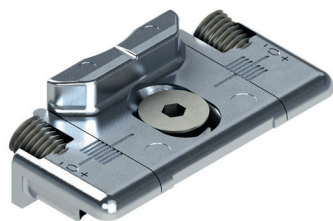

Functions

On the basis of the dimensions of the casement, the additional fastening mechanisms are to be used in conjunction with the Security Sash or Futura HP Bottom-Hung Windows mechanisms.

Online data sheet



01347K

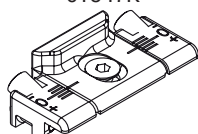

04777K

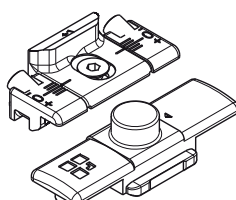

04048

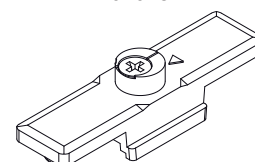

04019K

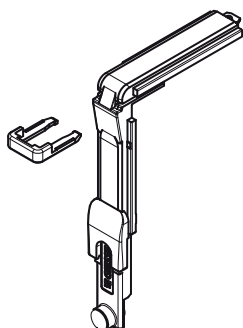

04301K

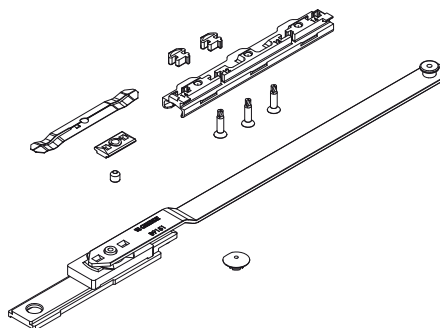

Item code	Description	PROFILE CROSS - SECTION	L (mm)	H (mm)	Base Raw	Anodised Elox	Painted	Trend/Gold Brass	Pieces per pack
01347K	CLOSING STRIKER	C001-C002-C003-C005-C011-C013-C014-C015-C016-C017-P001-P002-P004-P005-P006-P008-P009	-	1201 ÷ 2500	X				200
04019K	CORNER DRIVE FOR 01174K	C001-C002-C003-C005-C006-C013-C014-C015-C016-C017	1001 ÷ 1500	-	X				10
04301K	ADDITIONAL ARM FOR 01174K	C001-C002-C003-C005-C006-C011-C013-C014-C015-C016-C017	-	1201 ÷ 2500	X				5
04777K	HORIZONTAL ADDITIONAL FASTENING MECHANISM FOR 01175K	C001-C002-C003-C005-C006-C011-C013-C014-C015-C016-C017	751 ÷ 1500	-	X				50
04048	FIXED CONNECTION JOINT MX-MX	C007	-	1201 ÷ 2500	X				100

CONFIGURATION EXAMPLES**Horizontal security sash configuration with CHIC 100 hinges**

Sash width [mm]	452 ÷ 1500
Sash height [mm]	510 ÷ 2500
Horizontal security sash	01175K
KEY CAPTURE cremone	00961 - 01086 - 01192
Sash CHIC hinge	043541 - 043542

Vertical security sash configuration with CHIC 100 hinges

Sash width [mm]	800 ÷ 1500
Sash height [mm]	650 ÷ 2500
Horizontal security sash	01174K
KEY CAPTURE cremone	01192 - 01193
Sash CHIC hinge	043541 - 043542

HP BOTTOM-HUNG WINDOW

Functions

The HP bottom-hung window is a mechanism suitable for the construction of bottom-hung window casement weighing up to 250 kg.

Technical Features

The hardware allows the construction of casements with height up to 3000 mm and width up to 2500 mm.

Possibility to close the casement on three sides (excellent air-water-wind performance).

Operation:

- 0° mechanism - closed bottom-hung window
- 90° mechanism - open bottom-hung window

Making a HP bottom-hung window requires:

- Bottom-hung window kit
- Bottom-hung window hinges (CHIC VASISTAS, BRIDGE 2)
- Cremone with 90° block (ASIA, KORA, PRIMA, EURO)



FUTURA HP BOTTOM-HUNG WINDOW

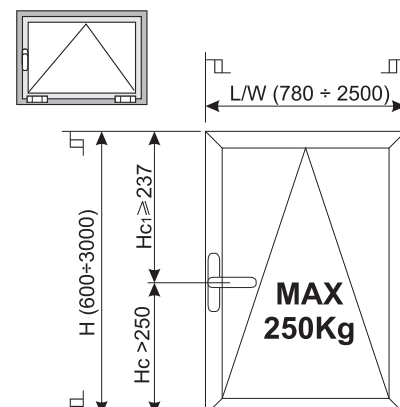
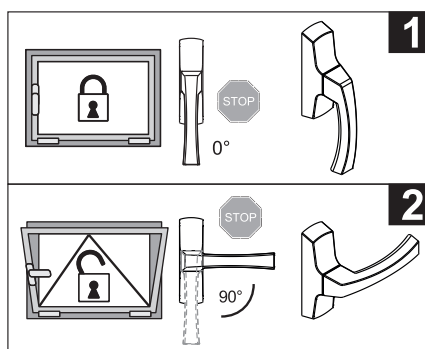
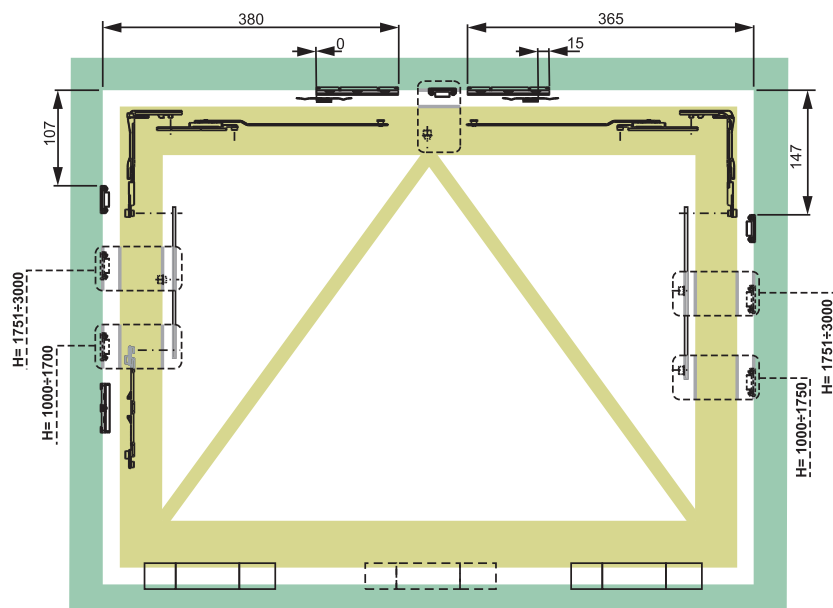

HP BOTTOM-HUNG WINDOW

HP BOTTOM-HUNG WINDOW KIT

Functions

Hardware kit for the construction of bottom-hung windows with capacities up to 250 kg and perimetral closing.

Online data sheet



Technical Features

The bottom-hung window requires a one-way cremone or a window handle, with or without a key, to which the 90° locking component (art. 02235) must be added.

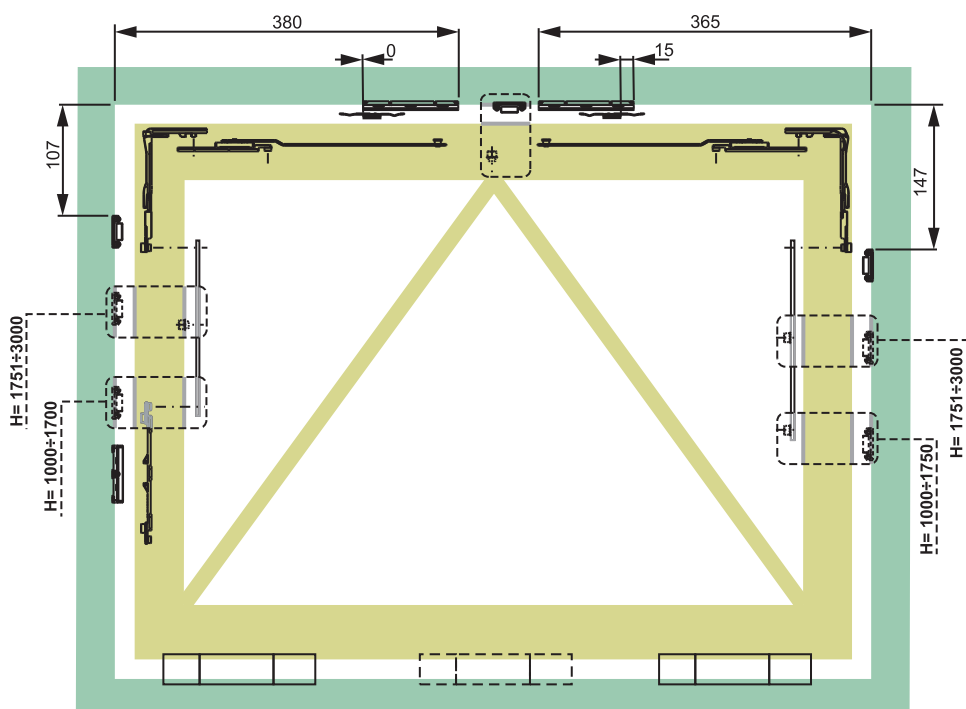
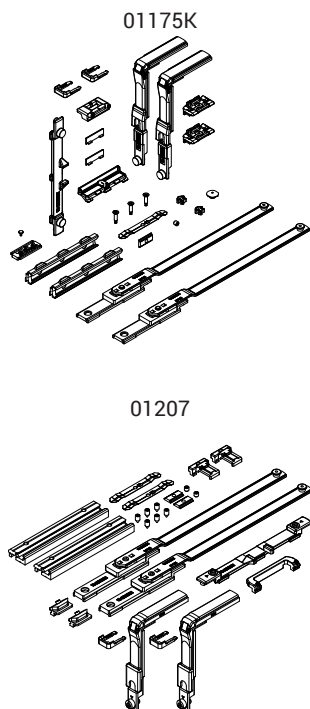

Item code	Description	PROFILE CROSS - SECTION	Bottom-hung window range [mm]	Base Raw	Anodised Elox	Painted	Trend/Gold Brass	Pieces per pack
01175K	FUTURA HORIZONTAL SECURITY SASH MECHANISM	C001-C002-C003-C004-C005-C006	W 780 ÷ 2500 H 600 ÷ 3000	X				10
01207	FUTURA HORIZONTAL SECURITY SASH MECHANISM	C007	W 780 ÷ 2500 H 600 ÷ 3000	X				10

HP BOTTOM-HUNG WINDOW CREMONE



Functions

Cremone usually used on tilt-and-turn window. For use on HP BOTTOM-HUNG WINDOW, it must be equipped with a mechanical block to be inserted inside, which limits its 90° rotation.

Online data sheet



00959

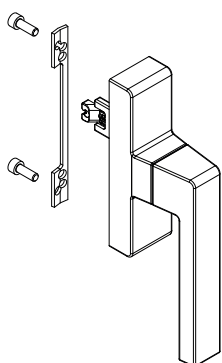

01039

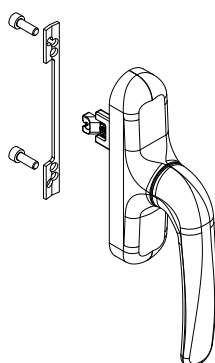

01084

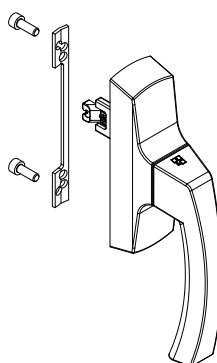

01094

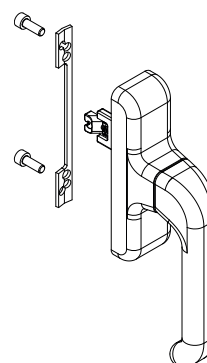

02235



Item code	Description	PROFILE CROSS - SECTION	C/C distances	Operation	Base Raw	Anodised Elox	Painted	Trend/Gold Brass	Pieces per pack
00959	KORA T/T MICRO-VENTILATION CREMONE	C001-C002-C003-C004-C005-C006-C007-C008-C009-C010-C012-C013-C014-C015-C016-C017	104 - 98 - 92 - 84	one-way	X		X	X	10
01039	PRIMA CREMONE	C001-C002-C003-C004-C005-C006-C007-C008-C009-C010-C012-C013-C014-C015-C016-C017	104 - 98 - 84	one-way	X		X	X	10
01084	KORA CREMONE	C001-C002-C003-C004-C005-C006-C007-C008-C009-C010-C012-C013-C014-C015-C016-C017	104 - 98 - 92 - 84	one-way	X		X	X	10
01094	EURO 900 MICRO CREMONE	C001-C002-C003-C004-C005-C006-C012-C013-C014-C015-C016-C017	104 - 98 - 84	one-way	X		X	X	10

Item code	Description	PROFILE CROSS - SECTION	Base Raw	Anodised Elox	Painted	Trend/Gold Brass	Pieces per pack
02235	90° CREMONE STOP BLOCK	-	X				100

HP BOTTOM-HUNG WINDOW HINGES

Functions

Based on the need for visible or concealed hinges, Bridge and Chic Vasistas hinges are available.

In both cases, in combination with the HP bottom-hung window kit, it is possible to make casements weighing up to 250 kg.

Online data sheet



00600N

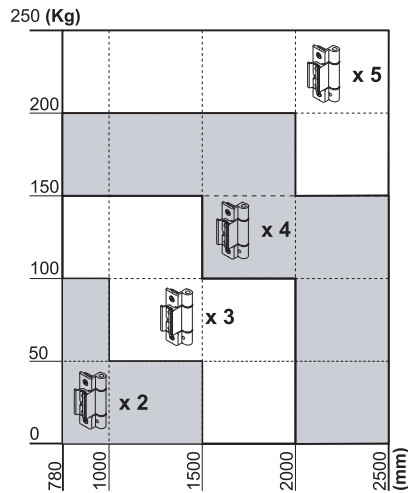
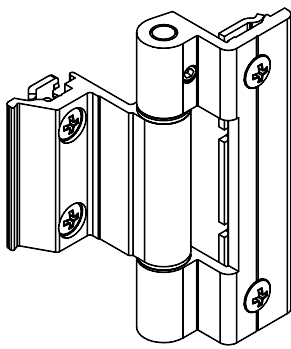

04362

04363

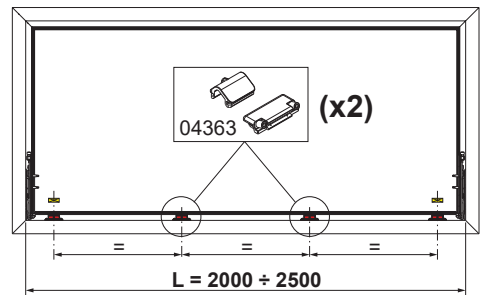
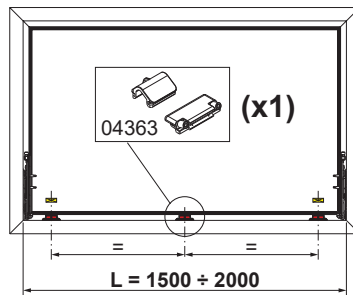
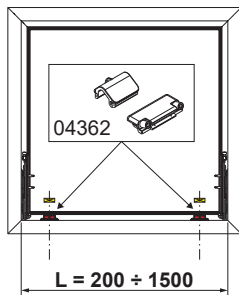
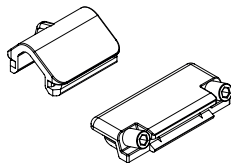
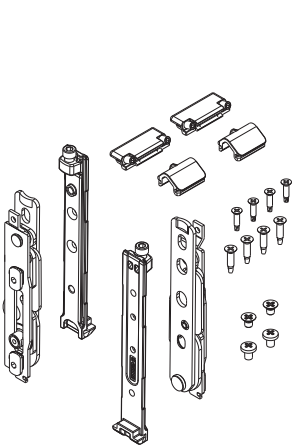

Item code	Description	PROFILE CROSS - SECTION	Base Raw	Anodised Elox	Painted	Trend/Gold Brass	Pieces per pack
00600N	BRIDGE 2 HINGE	C001-C002	X	X	X	X	20
04362	CHIC - BOTTOM-HUNG WINDOW HINGE KIT	C001-C002-C004-C005-C006	X				10
04363	CHIC - BOTTOM-HUNG WINDOW RAISING COMPONENT	C001-C002-C004-C005-C006	X				10

HP ERRE BOTTOM-HUNG WINDOW HINGES



Functions

Based on the need for visible or concealed hinges, Bridge and Chic Vasistas hinges are available.

In both cases, in combination with the HP bottom-hung window kit, it is possible to make casements weighing up to 250 kg.

Online data sheet



00602N

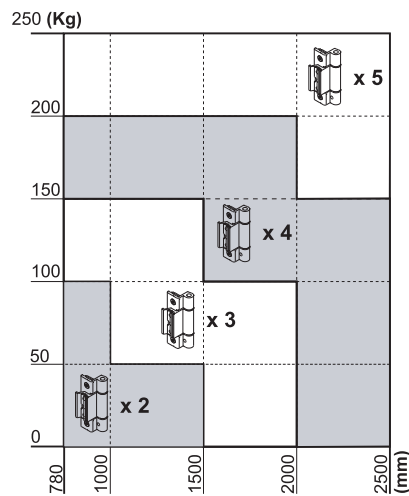
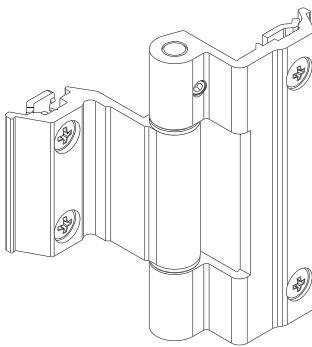

05295

05296

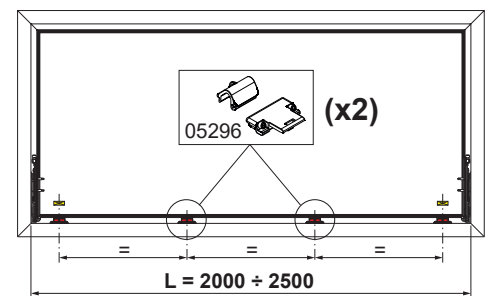
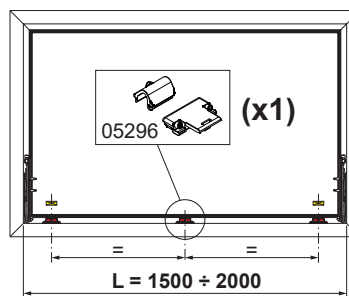
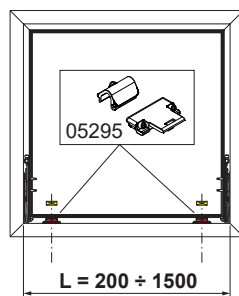
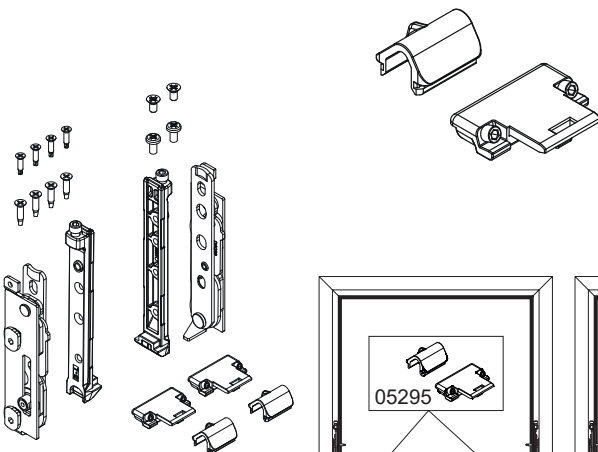

Item code	Description	PROFILE CROSS - SECTION	Base Raw	Anodised Elox	Painted	Trend/Gold Brass	Pieces per pack
00602N	BRIDGE 2 HINGE	C007	X	X	X	X	20
05295	CHIC ERRE - BOTTOM-HUNG WINDOW HINGES KIT	C007	X				10
05296	CHIC ERRE - BOTTOM-HUNG WINDOW HINGES RAISING COMPONENT	C007	X				10

HP BOTTOM-HUNG WINDOW ADDITIONAL FASTENING MECHANISMS

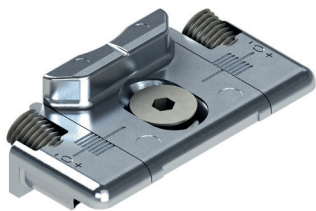

Functions

Additional hardware to be used according to the size of the sash.

Online data sheet



01347

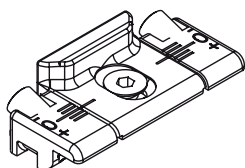

04027K



04048

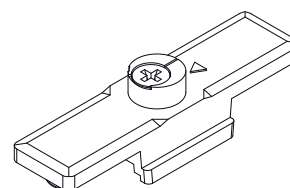

Item code	Description	PROFILE CROSS - SECTION	H (mm)	Base Raw	Anodised Elox	Painted	Trend/Gold Brass	Pieces per pack
01347K	CLOSING STRIKER	C001-C002-C003-C005-C011-C013-C014-C015-C016-C017-P001-P002-P004-P005-P006-P008-P009	1201 ÷ 2500	X				200
04027K	FUTURA FIXED PAWL	C001-C002-C003-C005-C006-C013-C014-C015-C016-C017-P001-P002-P003-P004-P005-P006-P008-P009-P010		X				200
04048	FIXED CONNECTION JOINT MX-MX	C007	1201 ÷ 2500	X				100

CONFIGURATION EXAMPLES

HP Bottom-Hung Window configuration with Bottom-hung window CHIC hinges

Sash width [mm]	780 - 2500
Sash height [mm]	600 - 3000
Horizontal security sash	01175K
HP Bottom-Hung Window Cremona	00959 - 01039 - 01084 - 01094
90° stop block	02235
Sash CHIC hinge	04362
Bottom-hung window lifting element (L>1500)	04362

HP Bottom-Hung Window configuration with BRIDGE hinges

Sash width [mm]	780 - 2500
Sash height [mm]	600 - 3000
Horizontal security sash	01175K
HP Bottom-Hung Window Cremona	00959 - 01039 - 01084 - 01094
90° stop block	02235
Bridge Hinge	00600N

VENTILATION SASH

VENTILATION SASH

Functions

Ventilation sash is hardware suitable for the construction of side-hung sashes, the main characteristic of which is that they are very narrow. It is particularly used on curtain walls.

Technical Features

Ventilation sash hardware is offered with CHIC concealed hinges used to make sashes up to a minimum width of 160 mm:

- 0° mechanism - closed sash
- 90° mechanism - open sash

Making a ventilation sash requires:

- CHIC 100 sash hinges
- Cremona, window handles and Giese SUPRA 7 window handles
- Fastening mechanisms (terminals and strikers)

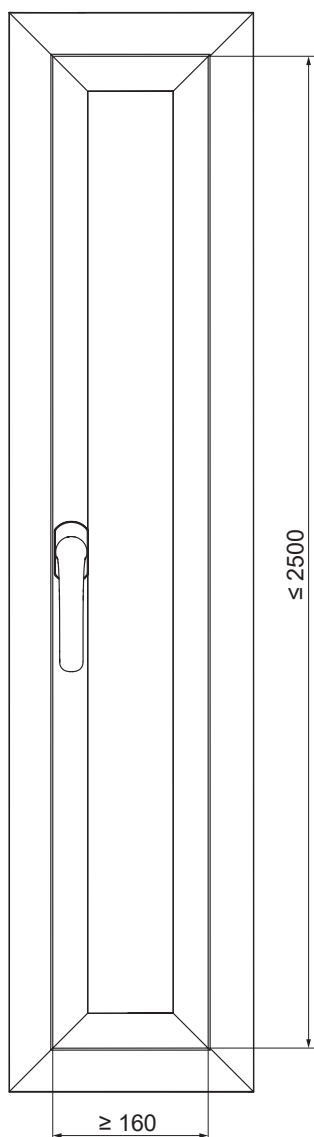

CONFIGURATION EXAMPLES

Ventilation sash configuration with standard profiles (two-way)

Article	Qty	Item code
Supra 7 window handle	1 pc.	04153 - 04154 - 04155 - 04156
Two-way movement	1 pc.	0102001
Giap terminal	2 pcs.	02114K - 02188K
Single striker	2 pcs.	01348K
CHIC - Sash hinge set	1 pc.	043541 - 043542

Ventilation sash configuration with minimal profiles (one-way)

Article	Qty	Item code
Supra 7 window handle	1 pc.	04153 - 04154 - 04155 - 04156
One-way movement	1 pc.	00949
Fixed pawl	2 pcs.	04027K
Adjustable striker	2 pcs.	01347K
CHIC - Sash hinge set	1 pc.	043541 - 043542



VENTILATION SASH HINGES

Functions

Set of hinges (top and bottom) for side-hung or secondary sash with tilt-and-turn CHIC 3D 100.

[Online data sheet](#)



Technical Features

Sash opening to 180°. Maximum load capacity 100 kg. Assembly is simple, fast and easy using the special pre-assembled cams. When there is an additional fastening mechanism, you need to use the CHIC fastening element. Both hinges are adjustable (3D). If opening is obstructed, you need to use the FRIZ limitation arm.
CAUTION: This hinge is designed to be used only on inward opening casements and is not suitable for outward opening casements.

Materials

Corner support made of zamak
 Connecting brackets and hinge plates made of zinc plated steel
 Pins made of 304 grade stainless steel and aluminium bronze
 Cams made of zinc plated steel

ADJUSTMENTS [mm]

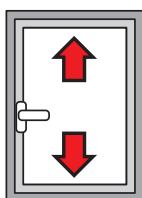

Height:
+2.5 / -1

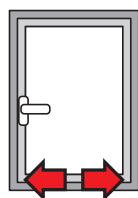

Side:
+1.5 / -1.5

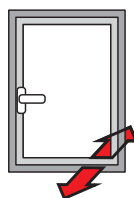

Hinge compression:
+1.4 / -0.6

Item code	Description	PROFILE CROSS - SECTION	Hand	Base Raw	Anodised Elox	Painted	Trend/Gold Brass	Pieces per pack
043541	CHIC - SASH HINGE SET	C001-C002-C003-C005-C006	RX	X				10
043542	CHIC - SASH HINGE SET	C001-C002-C003-C005-C006	LX	X				10

VENTILATION SASH MECHANISMS



Functions

Giesse Cremone and window-handles can be used to operate a Ventilation sash.

For space and design reasons, we recommend the use of the SUPRA 7 hammer, an innovative reversible mechanism system without washer, which can be used for moving window sashes with different types of opening, having mechanisms compatible with 7 mm square pins.

Online data sheet



Technical Features

Supra 7 window handles can be combined with Giesse sash drives and mechanisms and have a rotor with a 7 mm square hole.

They are available in four styles: ARIA, ASIA, KORA and PRIMA.

Two movements are available:

- 0102001 for standard profiles (11.1 mm backset) two-way
- 00949 for minimal profiles (3.5 mm backset), one-way

Materials

Handle in die-cast aluminium
Internal components made of GS SILVER PLUS zamak, zinc plated steel and white polyamide
Zinc plated steel fixing screws, with Eslock treatment

04153

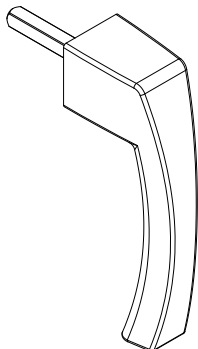

04154

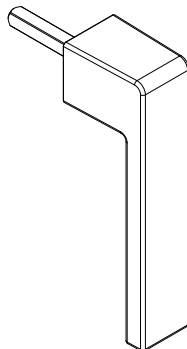

04155

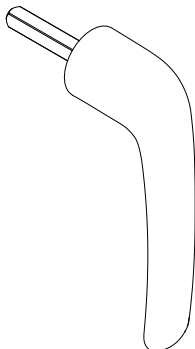

04156

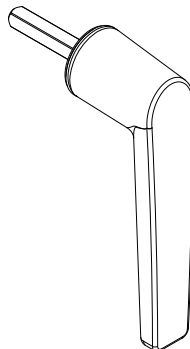

00949

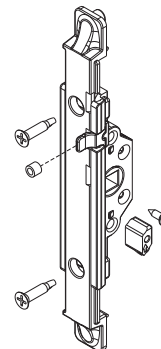

0102001

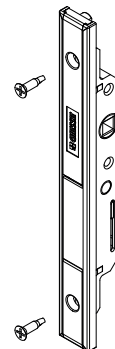

Item code	Description	Note	Base Raw	Anodised Elox	Painted	Trend/Gold Brass	Pieces per pack
04153	SUPRA 7 - ASIA MECHANISM		X		X	X	10
04154	SUPRA 7 - KORA MECHANISM		X		X	X	10
04155	SUPRA 7 - PRIMA MECHANISM		X		X	X	10
04156	SUPRA 7 - ARIA MECHANISM		X		X	X	10

Item code	Description	PROFILE CROSS - SECTION	Finish	Base Raw	Anodised Elox	Painted	Trend/Gold Brass	Pieces per pack
00949	ONE-WAY MECHANISM M180	C001-C002-C003-C004-C005-C006-C012-C013-C014-C015-C016-C017	GS Silver Plus	X				10
0102001	TWO-WAY INTERNAL MECHANISM	C001-C002-C003-C004-C005-C006-C009-C010-C012-C013-C014-C015-C016-C017-P001-P002-P004-P005-P006-P007-P008-P009-P010	GS Silver Plus	X				5

VENTILATION SASH FASTENING MECHANISMS

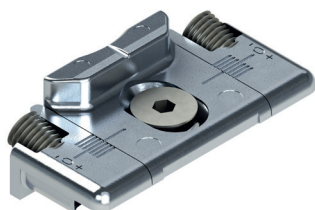

Functions

Depending on the fastening system (one-way or two-way), different fastening components such as terminals or pawls and their corresponding strikers are available.

Online data sheet



01347K

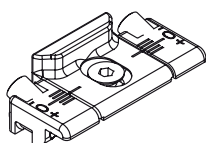

01348K

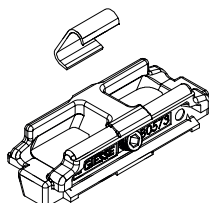

02114K



02188K

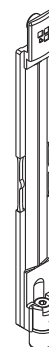

04027K



Item code	Description	Base Raw	Anodised Elox	Painted	Trend/Gold Brass	Pieces per pack
01347K	STRIKER	X				200
01348K	STRIKER	X				100
02114K	TERMINAL FOR RODS	X				50
02188K	FUTURA ADJUSTABLE TERMINAL	X				40
04027K	FUTURA FIXED PAWL	X				200

CHIC 100 SASH

CHIC 100 SASH

Functions

CHIC Sash is a mechanism used for manufacturing a modern and minimalist interior side-hung casement thanks to the possibility of combining CHIC hinges with 180° opening with the innovative SUPRA 7 window handle without rosette.

Technical Features

CHIC 100 Sash hardware is offered with concealed hinges used to make sashes up to a minimum width of 160 mm:

- 0° mechanism - closed sash
- 90° mechanism - open sash

Making a CHIC 100 Sash requires:

- CHIC 100 sash hinges
- SUPRA 7 or Cremona window handles and Giese window handles
- Fastening mechanisms (terminals and strikers)

Sash minimum and maximum dimensions:

Width: 160 – 1500 mm

Height: 600 – 2500 mm.



CONFIGURATION EXAMPLES

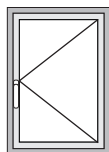

Single CHIC 100 Sash configuration with standard profiles (two-way)

Article	Qty	Item code
Supra 7 window handle	1 pc.	04153 - 04154 - 04155 - 04156
Two-way movement	1 pc.	0102001
Giap/Adjustable terminal	2 pcs.	02114K - 02188K
Single striker	2 pcs.	01348K
Raising component	1 pc.	02336
CHIC - Sash hinge set	1 pc.	043541 - 043542

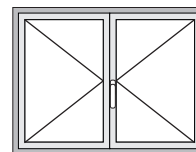

Double CHIC 100 sash configuration with standard profiles (two-way)

Article	Qty	Item code
Supra 7 window handle	1 pc.	04153 - 04154 - 04155 - 04156
Two-way movement	1 pc.	0102001
Giap/Adjustable terminal	2 pcs.	02114K - 02188K
Giap/Adjustable Bolt	2 pcs.	02111K - 02168K
Double striker	2 pcs.	01349
Raising component	2 pcs.	02336
CHIC - Right-hand sash hinge kit	1 pc.	043541
CHIC - Left-hand sash hinge kit	1 pc.	043542

Single CHIC 100 Sash configuration with minimal profiles (one-way)

Article	Qty	Item code
Supra 7 window handle	1 pc.	04153 - 04154 - 04155 - 04156
One-way movement	1 pc.	00949
Fixed pawl	2 pcs.	04027K
Adjustable striker	2 pcs.	01347K
Sash support cap	1 pc.	02336
CHIC - Sash hinge set	1 pc.	043541 - 043542

Double CHIC 100 Sash configuration with minimal profiles (one-way)

Article	Qty	Item code
Supra 7 window handle	1 pc.	04153 - 04154 - 04155 - 04156
One-way movement	1 pc.	00949
Fixed pawl	2 pcs.	04027K
Adjustable striker	2 pcs.	01347K
Giap/Adjustable Bolt	2 pcs.	02111K - 02168K
Main sash support cap	1 pc.	02336
Secondary sash support cap	1 pc.	02336
Single striker	2 pcs.	01348
CHIC - Right-hand sash hinge kit	1 pc.	043541
CHIC - Left-hand sash hinge kit	1 pc.	043542



CHIC 100 SASH HINGES

Functions

Concealed hinges, designed for traditional and minimal profiles, with sash weight up to 100 kg.

Online data sheet



Technical Features

This hinge is designed to be combined with reduced hardware dimensions in view, such as SUPRA 7.

Materials

Corner support made of zamak
 Connecting brackets and hinge plates made of zinc plated steel
 Pins made of 304 grade stainless steel and aluminium bronze
 Cams made of zinc plated steel

Table of maximum glass thickness [mm]

2500	33	27	23	20	18	16	15	14	13	12	11
2400	33	27	23	20	18	16	15	14	13	12	11
2300	34	28	24	21	19	17	16	14	13	12	11
2200	36	30	25	22	20	18	16	15	14	13	12
2100	37	31	27	23	21	19	17	16	14	13	12
2000	39	33	28	25	22	20	18	16	15	14	13
1900	41	34	30	26	23	21	19	17	16	15	14
1800	44	36	31	27	24	22	20	18	17	16	15
1700	46	38	33	29	26	23	21	19	18	16	15
1600	49	41	35	31	27	25	22	20	19	17	15
1500	50	44	37	33	29	26	24	22	20	17	15
1400	50	47	40	35	31	28	25	23	20	17	15
1300	50	50	43	38	34	30	27	24	20	17	15
1200	50	50	47	41	36	33	28	24	20	17	15
1100	50	50	50	45	40	34	28	24	20	17	
1000	50	50	50	49	42	34	28	24	20		
900	50	50	50	50	42	34	28	24			
800	50	50	50	50	42	34	28				
700	50	50	50	50	42	34					

Table of maximum load capacity [kg]

2500	100	100	100	100	100	100	100	100	100	100	100
2400	100	100	100	100	100	100	100	100	100	100	100
2300	100	100	100	100	100	100	100	100	100	100	100
2200	100	100	100	100	100	100	100	100	100	100	100
2100	100	100	100	100	100	100	100	100	100	100	100
2000	100	100	100	100	100	100	100	100	100	100	100
1900	100	100	100	100	100	100	100	100	100	100	100
1800	100	100	100	100	100	100	100	100	100	100	100
1700	100	100	100	100	100	100	100	100	100	100	98
1600	100	100	100	100	100	100	100	100	100	99	92
1500	100	100	100	100	100	100	100	100	100	93	87
1400	100	100	100	100	100	100	100	100	100	93	87
1300	100	100	100	100	100	100	100	100	94	87	75
1200	100	100	100	100	100	100	95	87	80	74	69
1100	100	100	100	100	100	95	87	79	73	68	
1000	100	100	100	100	96	87	79	72	67		
900	100	100	100	98	87	78	71	65			
800	100	100	99	87	77	69	63				
700	100	100	87	76	67	61					

ADJUSTMENTS [mm]

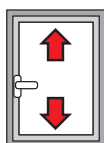

Height:
+2.5 / -1

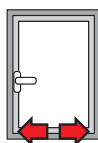

Side:
+1.5 / -1.5

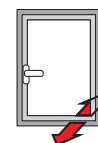

Hinge compression:
+1.4 / -0.6

Item code	Description	PROFILE CROSS - SECTION	Hand	Base Raw	Anodised Elox	Painted	Trend/Gold Brass	Pieces per pack
043541	CHIC - SASH HINGE SET	C001-C002-C003-C005-C006	RX	X				10
043542	CHIC - SASH HINGE SET	C001-C002-C003-C005-C006	LX	X				10



CHIC 100 SASH MECHANISM

Functions

Giesse Cremona and window handles can be used to operate a CHIC 100 sash.

For space and design reasons, we recommend the use of the SUPRA 7 hammer, an innovative reversible mechanism system without washer, which can be used for moving window sashes with different types of opening, having mechanisms compatible with 7 mm square pins.

Online data sheet



Technical Features

Supra 7 window handles can be combined with Giesse sash drives and mechanisms and have a rotor with a 7 mm square hole.

They are available in four styles: ARIA, ASIA, KORA and PRIMA.

Two movements are available:

- 0102001 for standard profiles (11.1 mm backset) two-way
- 00949 for minimal profiles (3.5 mm backset), one-way
- 0106101 for standard profiles (11.1 mm backset) one-way

Materials

Handle in die-cast aluminium
Internal components made of GS SILVER PLUS zamak, zinc plated steel and white polyamide
Zinc plated steel fixing screws, with Eslock treatment

04153

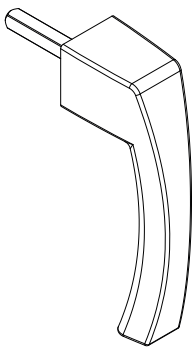

04154

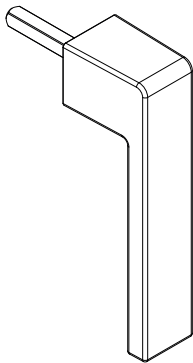

04155

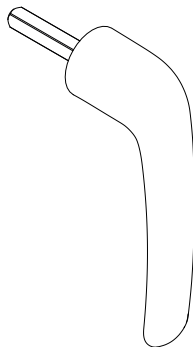

04156

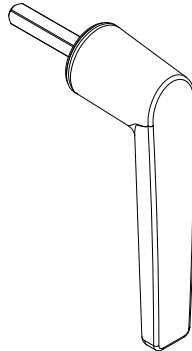

00949

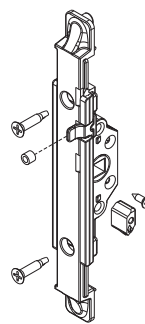

0102001

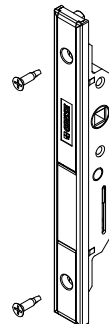

0106101

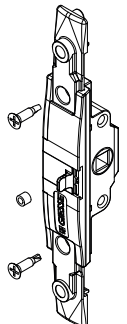

Item code	Description	Base Raw	Anodised Elox	Painted	Trend/Gold Brass	Pieces per pack
04153	SUPRA 7 - ASIA MECHANISM	X		X	X	10
04154	SUPRA 7 - KORA MECHANISM	X		X	X	10
04155	SUPRA 7 - PRIMA MECHANISM	X		X	X	10
04156	SUPRA 7 - ARIA MECHANISM	X		X	X	10

Item code	Description	PROFILE CROSS - SECTION	Finish	Base Raw	Anodised Elox	Painted	Trend/Gold Brass	Pieces per pack
00949	ONE-WAY MECHANISM M180	-	GS Silver Plus	X				10
0102001	TWO-WAY INTERNAL MECHANISM	C001-C002-C003-C004-C005-C006-C009-C010-C012-C013-C014-C015-C016-C017-P001-P002-P004-P005-P006-P007-P008-P009-P010	GS Silver Plus	X				5
0106101	ONE-WAY MECHANISM	-	GS Silver Plus	X				10

CHIC 100 SASH FASTENERS



Functions

Depending on the fastening system (one-way or two-way), different fastening components such as terminals or pawls and their corresponding strikers are available.

Online data sheet



01347K

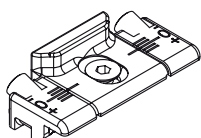

01348K

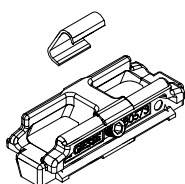

01349K

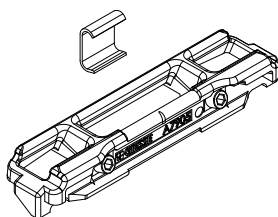

02111K

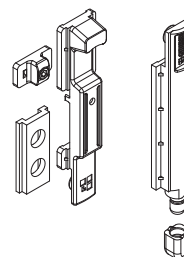

02114K



02168K

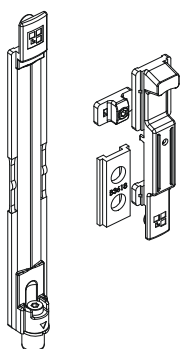

02188K

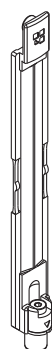

02309

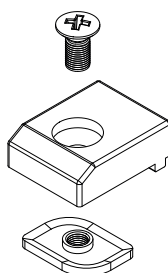

02336

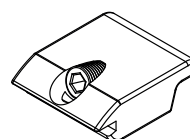

04027K

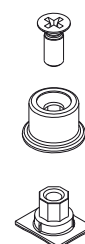

Item code	Description	Base Raw	Anodised Elox	Painted	Trend/Gold Brass	Pieces per pack
01347K	STRIKER	X				200
01348K	STRIKER	X				100
01349K	STRIKER	X				100
02111K	GIAP BOLT	X				50
02114K	TERMINAL FOR RODS	X				50
02168K	FUTURA ADJUSTABLE BOLT	X				10
02188K	FUTURA ADJUSTABLE TERMINAL	X				40
02309	SASH SUPPORT PLUG	X				100
02336	SASH SUPPORT PLUG	X				500
04027K	FUTURA FIXED PAWL	X				200

CHIC 130 SASH

CHIC 130 SASH

Functions

CHIC Sash is a mechanism used for manufacturing a modern and minimalist interior side-hung casement thanks to the possibility of combining CHIC hinges with 180° opening with the innovative SUPRA 7 window handle without rosette.

Technical Features

CHIC 130 Sash hardware is offered with concealed hinges used to make sashes up to a minimum width of 200 mm:

- 0° mechanism - closed sash
- 90° mechanism - open sash

Making a CHIC 130 Sash requires:

- CHIC 130 sash hinges
- SUPRA 7 or Cremona window handles and Giese window handles
- Fastening mechanisms (terminals and strikers)

Sash minimum and maximum dimensions:

Width: 200 – 1500 mm

Height: 600 – 2500 mm.



CONFIGURATION EXAMPLES

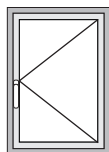

Single CHIC 130 Sash configuration with standard profiles (two-way)

Article	Qty	Item code
Supra 7 window handle	1 pc.	04153 - 04154 - 04155 - 04156
Two-way movement	1 pc.	0102001
Giap/Adjustable terminal	2 pcs.	02114K - 02188K
Single striker	2 pcs.	01348K
Raising component	1 pc.	02336
CHIC - Sash hinge set	1 pc.	044241 - 044242

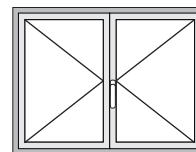

Double CHIC 130 sash configuration with standard profiles (two-way)

Article	Qty	Item code
Supra 7 window handle	1 pc.	04153 - 04154 - 04155 - 04156
Two-way movement	1 pc.	0102001
Giap/Adjustable terminal	2 pcs.	02114K - 02188K
Giap/Adjustable Bolt	2 pcs.	02111K - 02168K
Double striker	2 pcs.	01349
Raising component	2 pcs.	02336
CHIC - Right-hand sash hinge kit	1 pc.	044241
CHIC - Left-hand sash hinge kit	1 pc.	044242

Single CHIC 130 Sash configuration with minimal profiles (one-way)

Article	Qty	Item code
Supra 7 window handle	1 pc.	04153 - 04154 - 04155 - 04156
One-way movement	1 pc.	00949
Fixed pawl	2 pcs.	04027K
Adjustable striker	2 pcs.	01347K
Sash support cap	1 pc.	02306
CHIC - Sash hinge set	1 pc.	044241 - 044242

Double CHIC 130 Sash configuration with minimal profiles (one-way)

Article	Qty	Item code
Supra 7 window handle	1 pc.	04153 - 04154 - 04155 - 04156
One-way movement	1 pc.	00949
Fixed pawl	2 pcs.	04027K
Adjustable striker	2 pcs.	01347K
Giap/Adjustable Bolt	2 pcs.	02111K - 02168K
Main sash support cap	1 pc.	02306
Secondary sash support cap	1 pc.	02336
Single striker	2 pcs.	01348
CHIC - Right-hand sash hinge kit	1 pc.	044241
CHIC - Left-hand sash hinge kit	1 pc.	044242



CHIC 130 SASH MECHANISM

Functions

Giesse Cremona and window handles can be used to operate a CHIC 130 sash.

For space and design reasons, we recommend the use of the SUPRA 7 hammer, an innovative reversible mechanism system without washer, which can be used for moving window sashes with different types of opening, having mechanisms compatible with 7 mm square pins.

Online data sheet



Technical Features

Supra 7 window handles can be combined with Giesse sash drives and mechanisms and have a rotor with a 7 mm square hole.

They are available in four styles: ARIA, ASIA, KORA and PRIMA.

Two movements are available:

- 0102001 for standard profiles (11.1 mm backset) two-way
- 00949 for minimal profiles (3.5 mm backset), one-way
- 0106101 for standard profiles (11.1 mm backset) one-way

Materials

Handle in die-cast aluminium
Internal components made of GS SILVER PLUS zamak, zinc plated steel and white polyamide
Zinc plated steel fixing screws, with Eslock treatment

04153

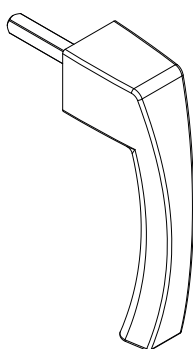

04154

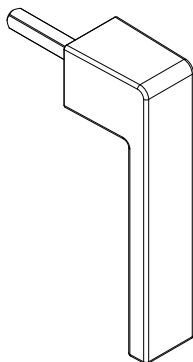

04155

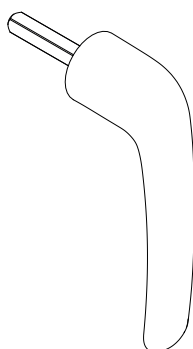

04156

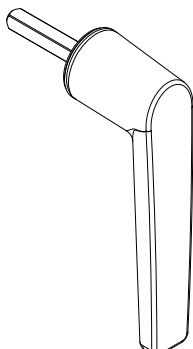

00949

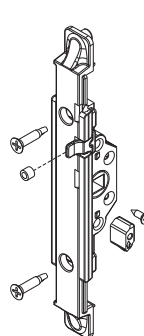

0102001

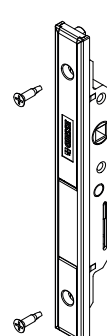

0106101

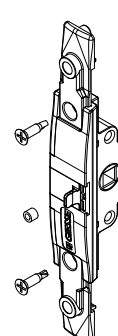

Item code	Description	Base Raw	Anodised Elox	Painted	Trend/Gold Brass	Pieces per pack
04153	SUPRA 7 - ASIA MECHANISM	X		X	X	10
04154	SUPRA 7 - KORA MECHANISM	X		X	X	10
04155	SUPRA 7 - PRIMA MECHANISM	X		X	X	10
04156	SUPRA 7 - ARIA MECHANISM	X		X	X	10

Item code	Description	PROFILE CROSS - SECTION	Finish	Base Raw	Anodised Elox	Painted	Trend/Gold Brass	Pieces per pack
00949	ONE-WAY MECHANISM M180	-	GS Silver Plus	X				10
0102001	TWO-WAY INTERNAL MECHANISM	C001-C002-C003-C004-C005-C006-C009-C010-C012-C013-C014-C015-C016-C017-P001-P002-P004-P005-P006-P007-P008-P009-P010	GS Silver Plus	X				5
0106101	ONE-WAY MECHANISM	-	GS Silver Plus	X				10

CHIC 130 SASH FASTENERS

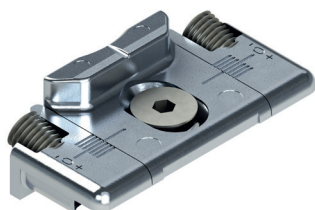

Functions

Depending on the fastening system (one-way or two-way), different fastening components such as terminals or pawls and their corresponding strikers are available.

Online data sheet



01347K

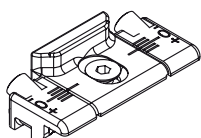

01348K

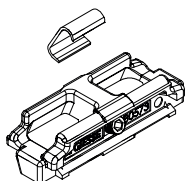

01349K

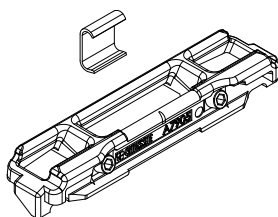

02111K

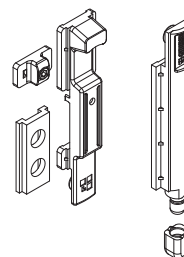

02114K



02168K

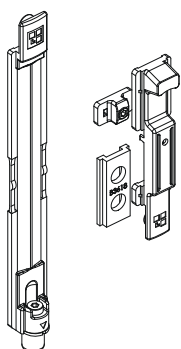

02188K

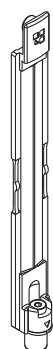

02309

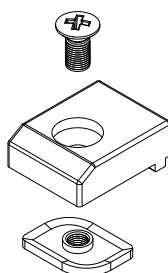

02336

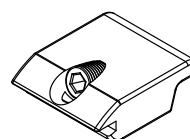

04027K

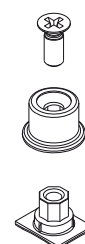

Item code	Description	Base Raw	Anodised Elox	Painted	Trend/Gold Brass	Pieces per pack
01347K	STRIKER	X				200
01348K	STRIKER	X				100
01349K	STRIKER	X				100
02111K	GIAP BOLT	X				50
02114K	TERMINAL FOR RODS	X				50
02168K	FUTURA ADJUSTABLE BOLT	X				10
02188K	FUTURA ADJUSTABLE TERMINAL	X				40
02309	SASH SUPPORT PLUG	X				100
02336	SASH SUPPORT PLUG	X				500
04027K	FUTURA FIXED PAWL	X				200

CHIC 130 ERRE SASH

CHIC 130 ERRE SASH

Functions

CHIC Sash is a mechanism used for manufacturing a modern and minimalist interior side-hung casement thanks to the possibility of combining CHIC hinges with 180° opening with the innovative SUPRA 7 window handle without rosette.

Technical Features

CHIC 130 ERRE Sash hardware is offered with concealed hinges used to make sashes up to a minimum width of 200 mm:

- 0° mechanism - closed sash
- 90° mechanism - open sash

Making a CHIC 130 ERRE Sash requires:

- CHIC 130 ERRE sash hinges
- SUPRA 7 or Cremona window handles and Giese window handles
- Fastening mechanisms (terminals and strikers)

Sash minimum and maximum dimensions:

Width: 200 – 1500 mm

Height: 600 – 2500 mm.



CONFIGURATION EXAMPLES

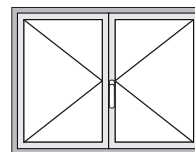
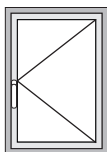

Single CHIC 130 ERRE Sash configuration (two-way)

Article	Qty	Item code
Supra 7 window handle	1 pc.	04153 - 04154 - 04155 - 04156
Two-way movement	1 pc.	0102001
Adapter kit	1 pc.	01190
Giap/Adjustable terminal	2 pcs.	02141K - 02085
Single striker	2 pcs.	01317K
Raising component	1 pc.	02366
CHIC - Sash hinge set	1 pc.	052831 - 052832

Double CHIC 130 ERRE Sash configuration (two-way)

Article	Qty	Item code
Supra 7 window handle	1 pc.	04153 - 04154 - 04155 - 04156
Two-way movement	1 pc.	0102001
Adapter kit	1 pc.	01190
Giap/Adjustable terminal	2 pcs.	02141K - 02085
Giap/Adjustable Bolt	2 pcs.	02131K - 04347
Double striker	2 pcs.	01215
Raising component	2 pcs.	02366
CHIC - Right-hand sash hinge kit	1 pc.	052831
CHIC - Left-hand sash hinge kit	1 pc.	052832



CHIC 130 ERRE SASH MECHANISM

Functions

Giesse Cremona and window handles can be used to operate a CHIC 130 ERRE sash.

For space and design reasons, we recommend the use of the SUPRA 7 hammer, an innovative reversible mechanism system without washer, which can be used for moving window sashes with different types of opening, having mechanisms compatible with 7 mm square pins.

Online data sheet



Technical Features

Supra 7 window handles can be combined with Giesse sash drives and mechanisms and have a rotor with a 7 mm square hole.

They are available in four styles: ARIA, ASIA, KORA and PRIMA.

Two movements are available:

- 0102001 + 01190 - M90 + two-way adapters (11.1mm backset)
- 01062 - one-way (11.1mm backset)

Materials

Handle in die-cast aluminium
Internal components made of GS SILVER PLUS zamak, zinc plated steel and white polyamide
Zinc plated steel fixing screws, with Eslock treatment

04153

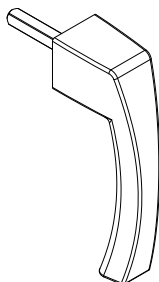

04154

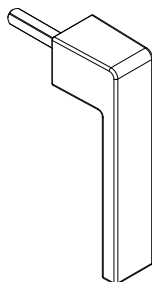

04155

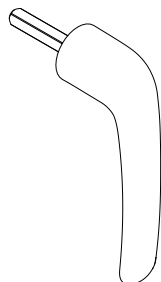

04156

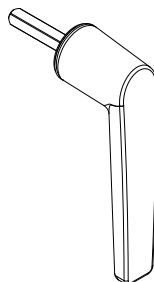

0102001

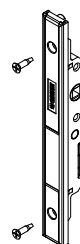

01190



01062

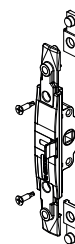

Item code	Description	Base Raw	Anodised Elox	Painted	Trend/Gold Brass	Pieces per pack
04153	SUPRA 7 - ASIA MECHANISM	X		X	X	10
04154	SUPRA 7 - KORA MECHANISM	X		X	X	10
04155	SUPRA 7 - PRIMA MECHANISM	X		X	X	10
04156	SUPRA 7 - ARIA MECHANISM	X		X	X	10

Item code	Description	PROFILE CROSS - SECTION	Finish	Base Raw	Anodised Elox	Painted	Trend/Gold Brass	Pieces per pack
0102001	TWO-WAY INTERNAL MECHANISM	C001-C002-C003-C004-C005-C006-C009-C010-C012-C013-C014-C015-C016-C017-P001-P002-P004-P005-P006-P007-P008-P009-P010	GS Silver Plus	X				5
01190	R40 ADAPTER KIT FOR TWO-WAY INWARD MOVEMENT	C007	-	X				10
01062	ONE-WAY MECHANISM M180	C007	GS Silver Plus	X				10

CHIC 130 ERRE SASH FASTENERS

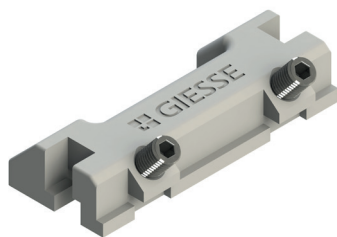

Functions

Depending on the fastening system (one-way or two-way), different fastening components such as terminals or pawls and their corresponding strikers are available.

Online data sheet



01215

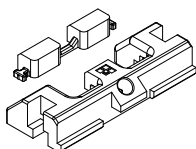

01317

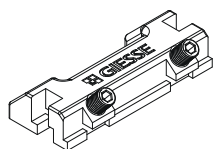

01344K

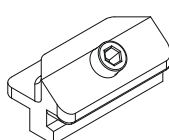

02085



02131K



02141K

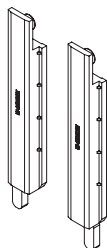

02366

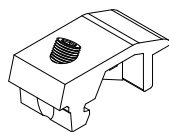

04030K



04347

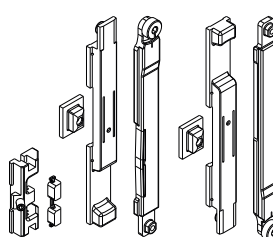

05288

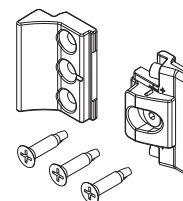

Item code	Description	Note	Base Raw	Anodised Elox	Painted	Trend/Gold Brass	Pieces per pack
01215	ZAMAK DOUBLE STRIKER		X				100
01317K	DOUBLE STRIKER	R40/R50 - silver plus	X				100
01344K	STRIKER FOR ADJUSTABLE FASTENER PAWL	silver plus	X				200
02085	ADJUSTABLE TERMINAL		X				40
02131K	GIAP BOLT	R40 - pair - silver plus	X				25
02141K	TERMINAL FOR RODS	R40 - pair - silver plus	X				25
02366	SASH SUPPORT PLUG		X				200
04030K	ADJUSTABLE LOCKING PAWL	silver plus	X				200
04347	ADJUSTABLE BOLT	pr	X				10
05288	CHIC - ADJUSTABLE FASTENING ELEMENT		X				25

GIESSE - BALCONY DOOR

GIESSE - BALCONY DOOR

Functions

Tilt-and-turn balcony door, which can also be operated from the outside. If required, it can also be fitted with a lock to increase security. Especially suitable for terraces or patios.

Technical Features

The tilt-and-turn balcony door is available for both traditional FUTURA and concealed CHIC mechanism, and is operated using standard or SUPRA 7 GIESSE (double) window handles.

As a replacement for the traditional movement, the 32 mm backset must be used, which allows for the application of the double window handle.

If required, the lock makes the system more secure.

The following is required to make a tilt and turn sash on a Balcony door:

- CHIC or FUTURA hinges and arms
- tilt-and-turn mechanism with M180 movement 32 mm backset
- SUPRA 7 double window handles
- 32 mm backset lock

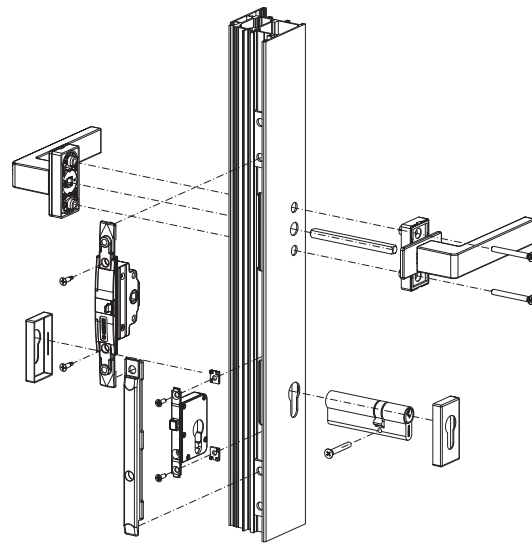
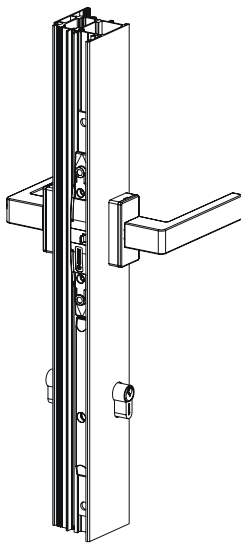

CONFIGURATION EXAMPLES

Balcony Door FUTURA 130 configuration

Article	Qty	Item code
SUPRA 7 double window handle	1 pc.	04395 - 04396 - 04397 - 04398
T&T mechanism	1 pc.	00947 or 04704 + 00945
Lock	1 pc.	00946
Hinges	1 pc.	04711
Arms	1 pc.	04284 - 04285
Cylinder	1 pc.	see DOOR CYLINDERS

Balcony Door CHIC 100 configuration

Article	Qty	Item code
SUPRA 7 double window handle	1 pc.	04395 - 04396 - 04397 - 04398
T&T mechanism	1 pc.	00947 or 04704 + 00945
Lock	1 pc.	00946
Hinges + arm kit	1 pc.	043551/043552 - 043561/043562
Cylinder	1 pc.	see DOOR CYLINDERS

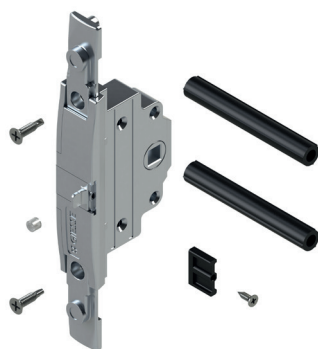

MOVEMENT M180 BACKSET 32 MM

Functions

One-way mechanism, operated by window handle, to be inserted in the tubular section of the profile for the movement of GIESSE tilt-and-turn and turn-only sash closing mechanism.

Online data sheet



Technical Features

The movement is reversible and can be combined with all conventional GIESSE and SUPRA 7 window handles.

The 32 mm backset allows to apply the window handle from the outside and consequently the sash can also be operated from the outside.

Combined with lock 00946, it allows the construction of balcony door casements with turn-only and tilt-and-turn sashes.

Designed for application on tilt-and-turn sashes, it can be applied on the turn-only sash by limiting the rotation of the handle to 90° by means of a specific stop component.

Both the T&T mechanism complete with 00947 movement as well as the 00947 movement to be combined with the T&T mechanism 04704 are available if already in stock.

Materials

Rack, case, incorrect movement safety device slide, cover for mechanism and gear in die-cast zamak.

Shims in black polyamide.

Screws and spring of zinc-nickel plated steel.

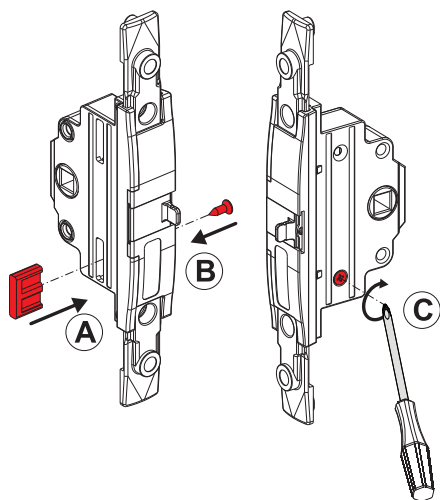

Item code	Descriptions	Notes	Base Raw	Anodised Elox	Painted	Trend/Gold Brass	Pieces per pack
00945	M180 ONE-WAY MOVEMENT	to be combined with 04704	X				5

Item code	Descriptions	PROFILE CROSS - SECTION	Mechanism	Version	Base Raw	Anodised Elox	Painted	Trend/Gold Brass	Pieces per pack
00947	T/T M 180 MOVEMENT FASTENING MECHANISM	C001-C002-C003-C005-C006-C013-C014-C015-C017	Window handle	-	X				10

LOCK FOR BALCONY DOOR



Functions

A lock which, when combined with the 32 mm backset movement, makes it possible to create so-called turn-only and tilt-and-turn balcony door sashes.

Online data sheet



Technical Features

The lock is reversible and can be combined with the 00945 movement (32 mm backset) and all traditional GIESSE and SUPRA 7 window handles. This lock can be fitted on both turn-only and tilt-and-turn sashes and thanks to the 32 mm backset allows the application of Giesse cylinders (European profile) and consequently the sash can also be locked from the outside.

Materials

Lock body and movable component in die-cast zamak.
Shims in black polyamide.
Screws with Zi-Ni finish.

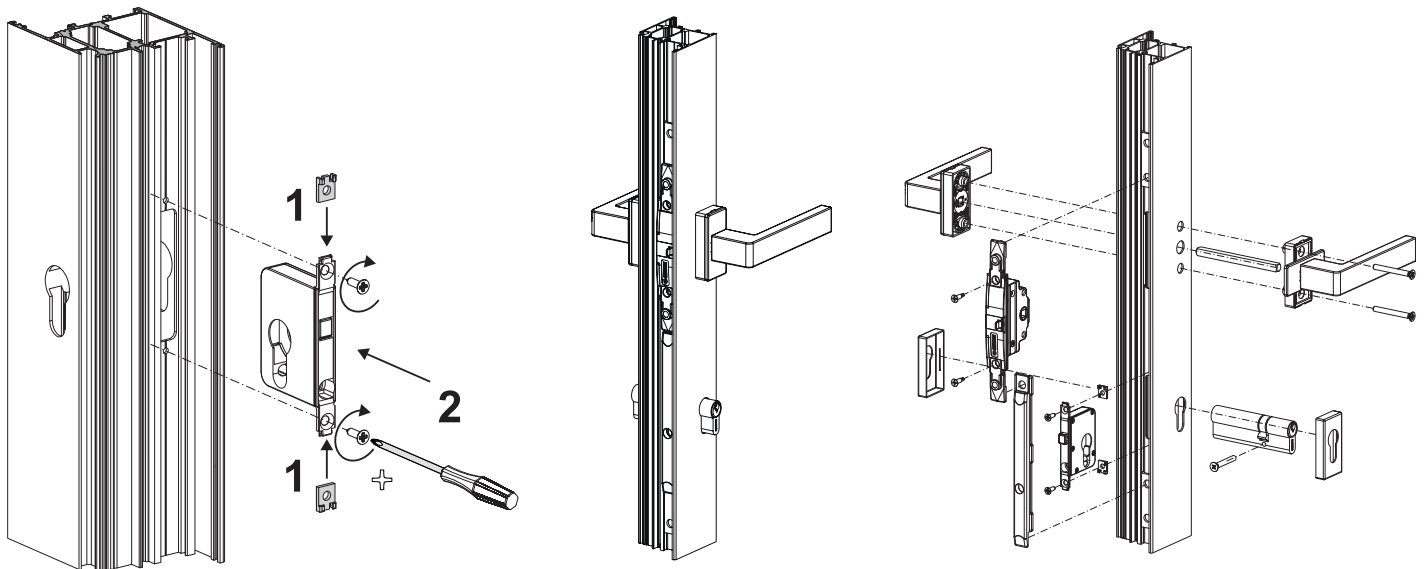

Item code	Descriptions	Note	Base Raw	Anodised Elox	Painted	Trend/Gold Brass	Pieces per pack
00946	LOCK FOR TILT-AND-TURN WINDOW		X				5



SUPRA 7 - DOUBLE WINDOW HANDLES

Functions

Innovative double mechanism system without washer which can be used for moving window sashes with different types of opening, having mechanisms compatible with 7 mm square pins and which can be combined with all Giesse products having the same design.

Online data sheet



Technical Features

The Supra 7 double window handles can be combined with the Giesse sliding casement and side-hung sash movements and mechanisms which have a rotor compatible with 7 mm square pins.

The product, due to its exclusive design, can be combined with all the other Giesse products having the same design intended for other types of sashes (door, handles for lift-and-slide etc.).

Products applicable on sash with profiles wide from 26 to 85 mm.

Materials

Handle in die-cast aluminium

Internal components made of GS SILVER PLUS zamak, zinc plated steel and white polyamide

Zinc plated steel fixing screws, with Eslock treatment

Fixing with 45° or 90° machining

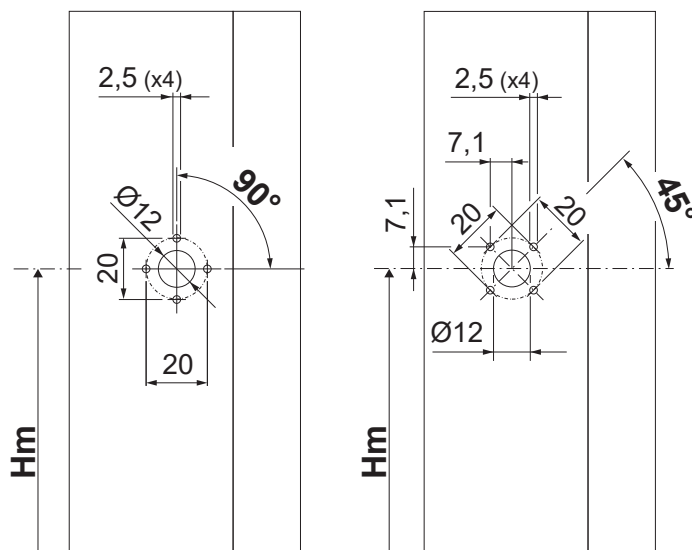

GIESSE - BALCONY DOOR

04395

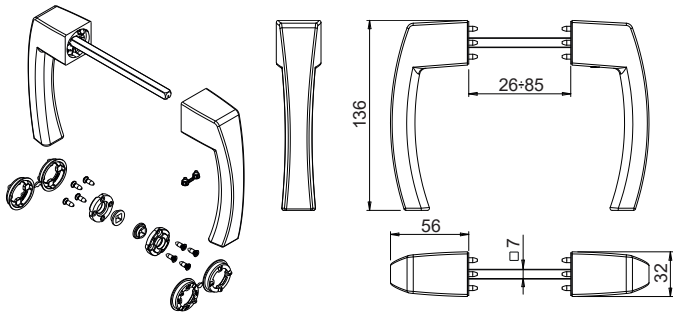

04396

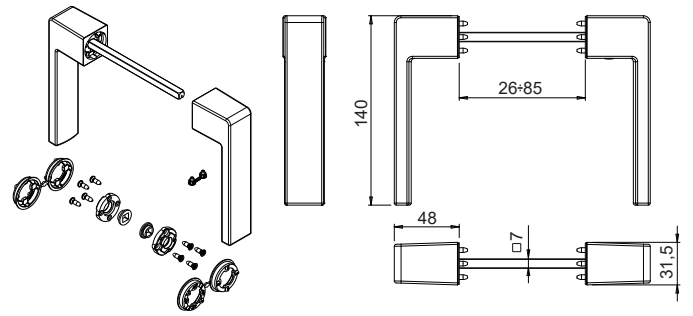

04397

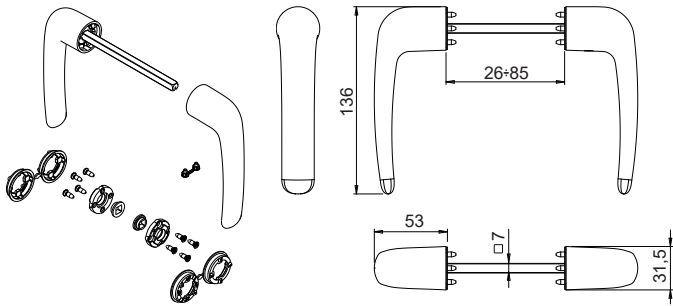

04398

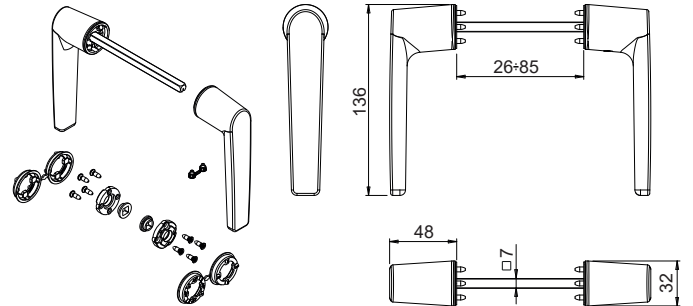

Item code	Description	Type of pin (mm)	Pin length (mm)	Sash width (mm)	Pull handle 0°	Pull handle 90°	Base Raw	Anodised Elox	Painted	Trend/Gold Brass	Pieces per pack
04395	SUPRA 7 - ASIA DOUBLE WINDOW HANDLE	7	112	26 ÷ 85	Closed	Open	X		X	X	5
04396	SUPRA 7 - KORA DOUBLE WINDOW HANDLE	7	112	26 ÷ 85	Closed	Open	X		X	X	5
04397	SUPRA 7 - PRIMA DOUBLE WINDOW HANDLE	7	112	26 ÷ 85	Closed	Open	X		X	X	5
04398	SUPRA 7 - ARIA DOUBLE WINDOW HANDLE	7	112	26 ÷ 85	Closed	Open	X		X	X	5

CHIC 100 TILT-AND-TURN HINGES AND ARMS



Functions

Hinge kit (upper and lower), completely pre-assembled and ready to be installed on the profile.

Online data sheet



Technical Features

They enable tilt-and-turn opening combined with the mechanisms. Micro-ventilation and logica versions. The arm is equipped with micro-ventilation as standard (adjustable). Moving the fastening pawl takes the arm from conventional to logica. The T2 arm is adjustable: the opening "A" goes from 178 mm (base) to 148 mm.

Materials

Corner support made of zamak
 Connecting brackets and hinge plates made of zinc plated steel
 Pins made of 304 grade stainless steel and aluminium bronze
 Cams made of zinc plated steel
 Connecting bracket and arm rod made of 304 grade stainless steel

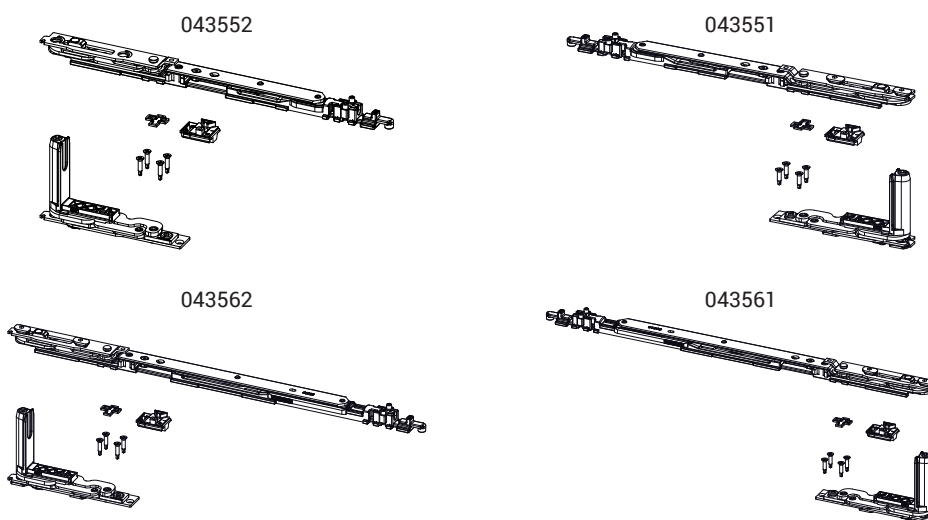
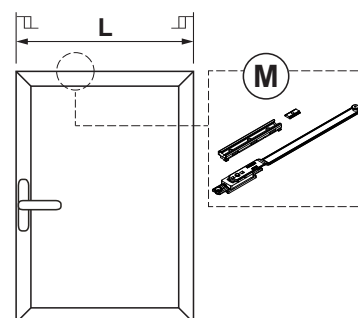

T2		T2		T2+M
T1	T1	T1	T1+M	
680	805	1000	1130	1600
L				

Sash opening

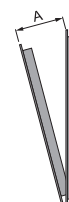

Item code	Description	PROFILE CROSS - SECTION	A (mm)	Hand	Base Raw	Anodised Elox	Painted	Trend/Gold Brass	Pieces per pack
043551	CHIC - T1 ARM T&T KIT	C001-C002-C003-C005-C006	98	RX	X				10
043552	CHIC - T1 ARM T&T KIT	C001-C002-C003-C005-C006	98	LX	X				10
043561	CHIC - T2 ARM T&T KIT	C001-C002-C003-C005-C006	148÷178	RX	X				10
043562	CHIC - T2 ARM T&T KIT	C001-C002-C003-C005-C006	148÷178	LX	X				10

FUTURA 3D 130 HINGES AND ARMS

Functions

Futura 3D 130 tilt-and-turn hinge set (upper and lower) and arm.

Online data sheet



Technical Features

Hinges: hinge set (upper and lower), completely pre-assembled and ready to be installed on the profile.

Arms: allow tilt-and-turn opening in conjunction with tilt-and-turn hinges and mechanisms.

Materials

Hinges:

- Body of hinges in extruded aluminium and brass
- Supports in zamak with GS Silver Plus finish (up to 500 h corrosion resistance)
- Pins, screws and grub screws in stainless steel

Arms:

- Body, fixing block and slider in zamak with GS Silver Plus finish (up to 500 h corrosion resistance)
- Rod, connecting bracket, grub screws and screws in stainless steel
- Stop disk in polyamide

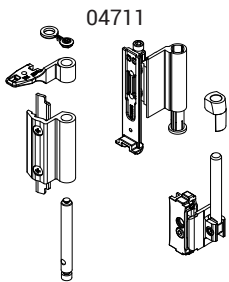
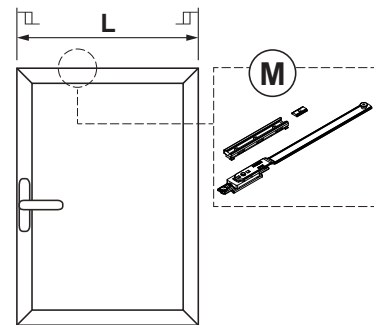

04284

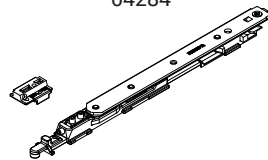

04285

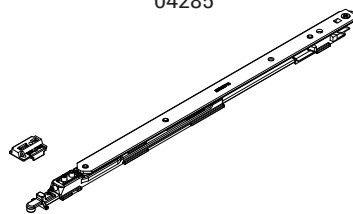

T2		T2		T2+M
T1	T1	T1	T1+M	
625	780	1000	1100	1600
L				

Sash opening



Item code	Description	PROFILE CROSS - SECTION	Base Raw	Anodised Elox	Painted	Trend/Gold Brass	Pieces per pack
04711	HINGE T/T FUTURA 130	C001-C002-C003-C005-C006	X		X	X	10

Item code	Description	PROFILE CROSS - SECTION	A (mm)	Base Raw	Anodised Elox	Painted	Trend/Gold Brass	Pieces per pack
04284	ARM T1 130 WITH MICROVENTILATION	C001-C002-C003-C015-C016-C017	120					10
04285	ARM T2 130 WITH MICROVENTILATION	C001-C002-C003-C015-C016-C017	175					10

OS OPERATOR

Functions

Complete system of opening, closing and multilocking, for top hung and side hung outward opening casement windows.

Technical Features

The OS Operator system to be applied requires a specific profile cross-section. OS Operator has a push/pull force of 50 Nm.

The OS Operator System performs a dual function:

1. The sash is moved from the closed position to the open position, limited in safety.
2. The locking points engage and disengage.

Making the OS Operator casement always requires:

- Unica Cremone for OS Operator (1 pc)
- OS Operator fastening mechanism (1 pc)
- Arm for OS Operator (1 pc)

Possible dimensions

They are determined by the overall dimensions of the mechanism (standard and reduced)



OS OPERATOR type profile cross-sections

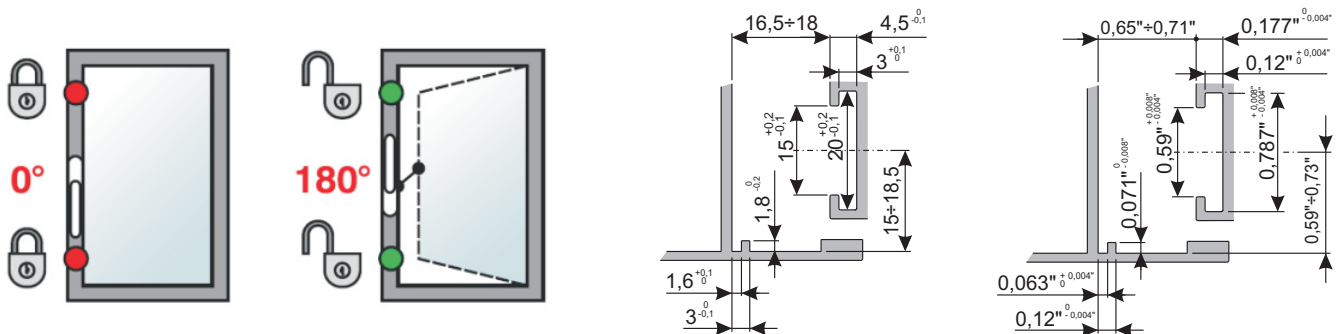

* If this dimension is ≤ 550 mm, use Loose Rivet swing-out arms for supporting the sash

* If this dimension is ≤ 550 mm, use Loose Rivet swing-out arms for supporting the sash

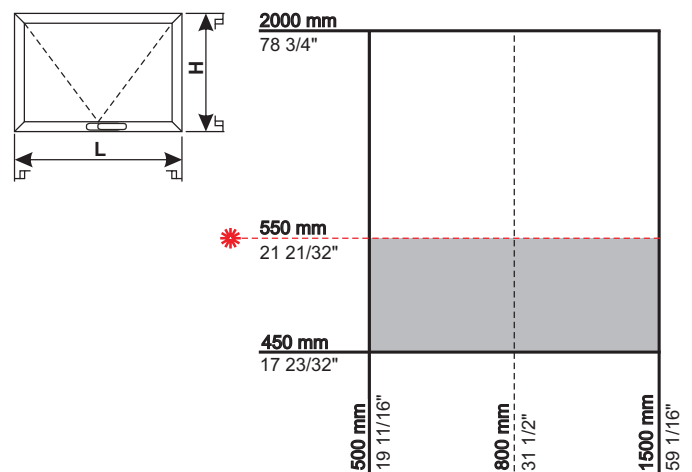
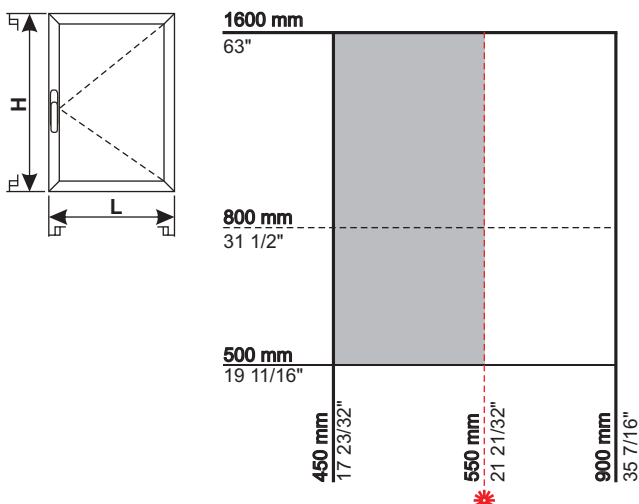

UNICA OS OPERATOR CREMONE



Functions

Unica line Cremone, dedicated to the OS OPERATOR mechanism.

Online data sheet



Technical Features

Compared to the standard cremones, these rotate with positioning notches at 0° and 180°.

Turning the pull handle of the cremone to 180° first unlocks the locking points (approximately 60°) and then takes the sash into the position of maximum opening (trip to 180° of the cremone).

The high stresses to which the casement is subjected when opening and closing has meant that for OS Operator there is a complete range of specific cremones. In addition to the Unica standard cremone, Key, Away and long handle versions are available. In particular, the one with the long handle reduces the effort when opening the casement and makes operation smoother.

The rotor and slider of all OS operator cremones are made of stainless steel to ensure maximum mechanical strength.

It is recommended to use the special gasket, made of black closed-cell foam adhesive on one side, which enables reducing the flow of air and water through the milling on the profile and the cremone case.

Materials

Handle in die-cast aluminium

Die-cast zamak cremone case

Internal rotor and slider in 304 grade stainless steel

Spring in harmonic steel

Black polyamide plate

Trip disc 0° - 180° in black polyamide

Unica OS Operator Cremone

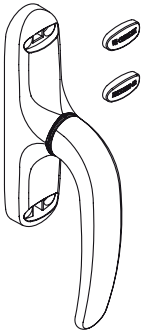

Unica Away OS Operator Cremone

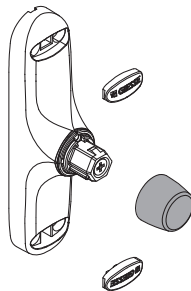

Long pull handle Unica OS Operator Cremone

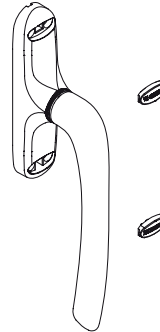

Unica Key OS Operator Cremone

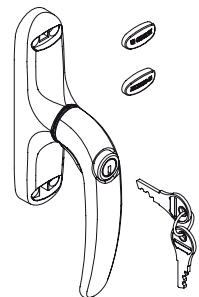

Item code	Description	Version	Pull handle length	Handle match	Pull handle 0°	Pull handle 180°	Base Raw	Anodised Elox	Painted	Trend/Gold Brass	Pieces per pack
01127	CREM. UNICA OS OPERATOR - AWAY	Away		01129	Closed	Open			X		10
01128	CREM. UNICA OS OPER. LONG HANDLE	Standard	172 mm		Closed	Open			X		10
01129	PULL HANDLE FOR UNICA AWAY	Away	172 mm	01127	Closed	Open			X		10
01171	UNICA OS OPERATOR CREMONE	Standard	121 mm		Closed	Open			X		10
01172	UNICA KEY OS OPERATOR CREMONE	Key	121 mm		Closed	Open			X		10
06951	UNICA CREM. GASKET						X				100

OS OPERATOR MECHANISMS

**Functions**

Two-handed mechanism that moves the sash of a Top or Side Hung aluminium casement, creating 2 locking points on the casement.

Online data sheet

**Technical Features**

The mechanism is available in two versions:

- standard (overall size of mechanism 725 mm)
- reduced for small doors (overall size of mechanism 466.5 mm) available both left and right.

For particularly high side hung windows or very wide top hung windows it is possible to connect the extension to both sides of the mechanism.

Locking point adjustment

You can adjust the 2 locking points both in compression (± 3.2 mm) and side (± 3 mm).

Materials

- a) Main body (guide), in extruded aluminium, silver anodized
 - b) Internal rod, in extruded aluminium, silver anodized
 - c) Adjustable pawl, in zamak, Giesse Silver Plus
 - d) Pinion, in 304 grade stainless steel
 - e) Rack drive rod, in 304 stainless steel
 - f) Casing, in Giesse Silver Plus zamak
 - g) Frame striker, in zamak, Giesse Silver Plus
- Fixing screws in 304 grade stainless steel

Standard mechanism

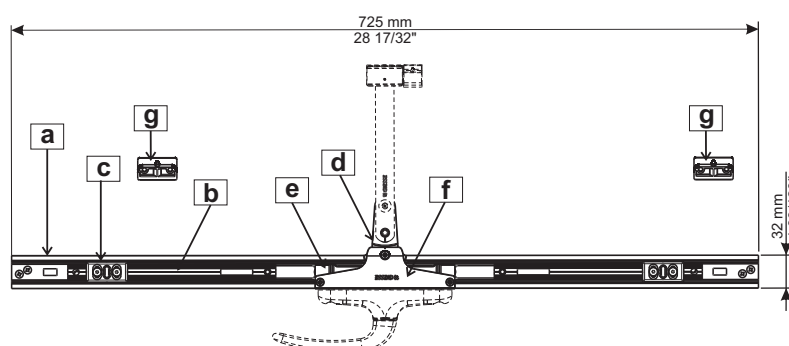

Reduced mechanism

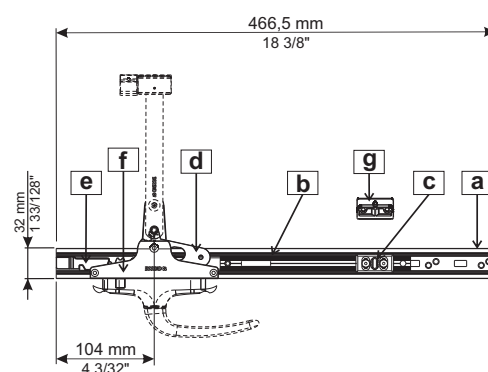

Locking point adjustment

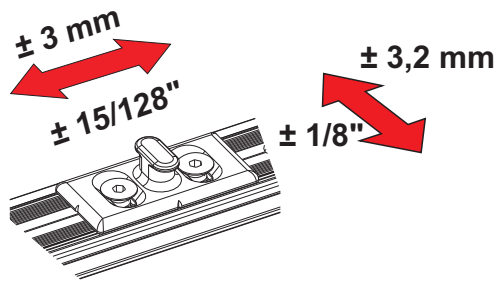

Standard mechanism

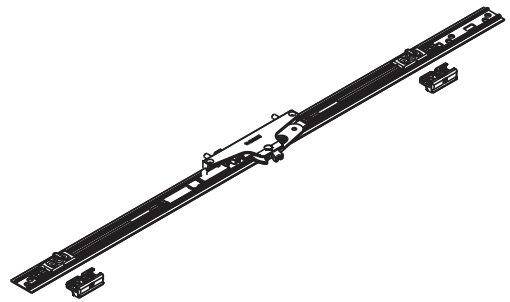

Right-hand reduced mechanism

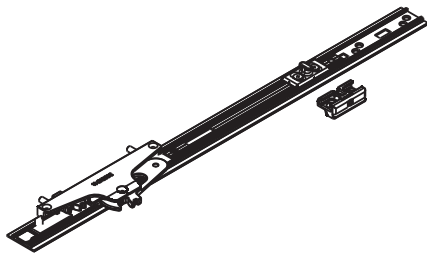

Left-hand reduced mechanism

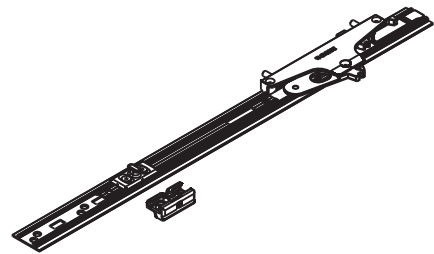

Item code	Description	Version	Hand	Length	Symmetric	Locking points	Extension	Base Raw	Anodised Elox	Painted	Trend/Gold Brass	Pieces per pack
02000	OS OPERATOR MECHANISM	Standard	RH - LH	725 mm	Yes	2	Above/below max 3 pieces (2+1)	X				10
020021	OS OPERATOR MECHANISM	Reduced	RX	466.5 mm	No	1	Only above max 2 pieces	X				10
020022	OS OPERATOR MECHANISM	Reduced	LX	466.5 mm	No	1	Only above max 2 pieces	X				10

EXTENSIONS



Functions

350 mm (13 25/32") extension for use with an OS Operator mechanism to create a supplementary locking point.

Online data sheet



Technical Features

Fixing to the frame profile is done with the self-tapping screws supplied and connecting to the mechanism is done with a connection element. The pawl on the extension can be adjusted.

Materials

Polyamide joint
 Extension in extruded aluminium
 Adjustable pawl and striker in zamak
 Stainless steel screws, grub screws and fixing plates

Locking point adjustment

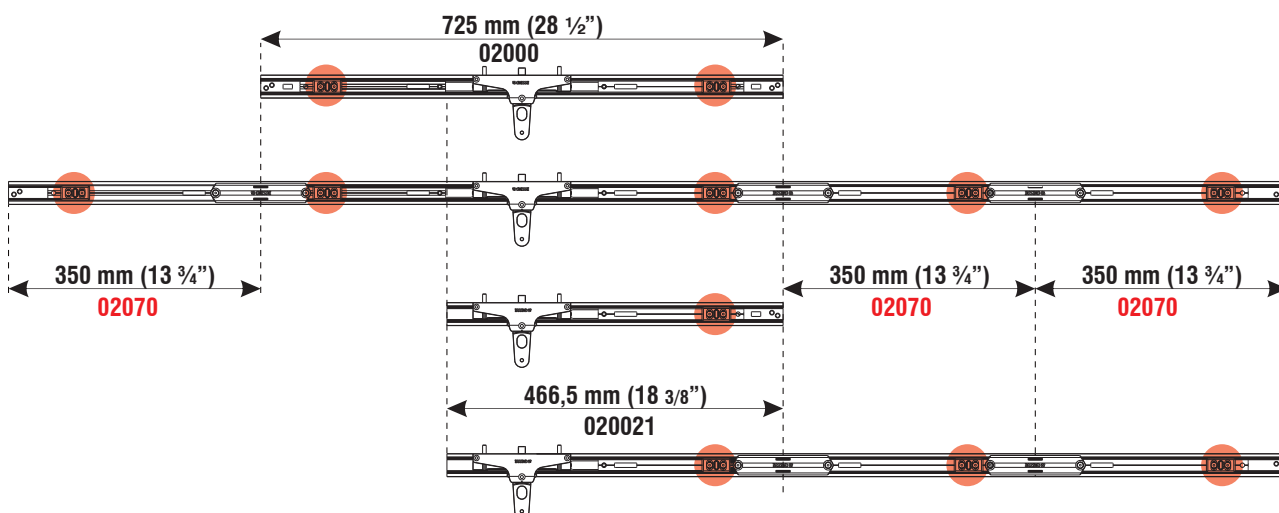
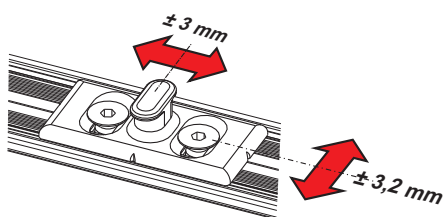

Item code	Description	Length	Can be combined with	Base Raw	Anodised Elox	Painted	Trend/Gold Brass	Pieces per pack
02070	OS OPERATOR EXTENSION	350 mm	02000 02002 1 02002 2	X				10

OS OPERATOR ARMS

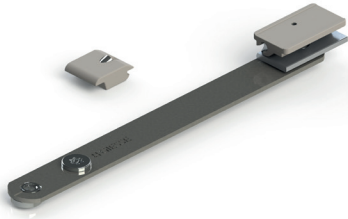

Functions

The arm for OS Operator performs the function of pushing the sash from the "sash closed" position to the "fully open" position and vice versa.

Online data sheet



Technical Features

Available in two lengths (172 mm and 152 mm), The arm is attached to an OS Operator mechanism using the screw with security head Torx T30 (A).

The slider, available in both polyamide and aluminium, runs in the 15/20 mm channel on the mobile sash. A polyamide stop component provides the limit stop position.

You can, with the aid of the eccentric pin (B), using a T30 torx wrench, adjust the position of the slider and then obtain the optimal position for the sash during the phase of activating the locking points.

Materials

Arm in stainless steel 304

Slider in extruded aluminium or grey polyamide

Grey polyamide stop

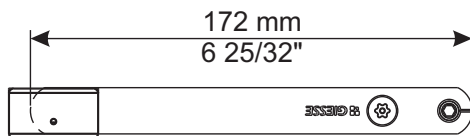

Z = Distance between the profiles (see table)

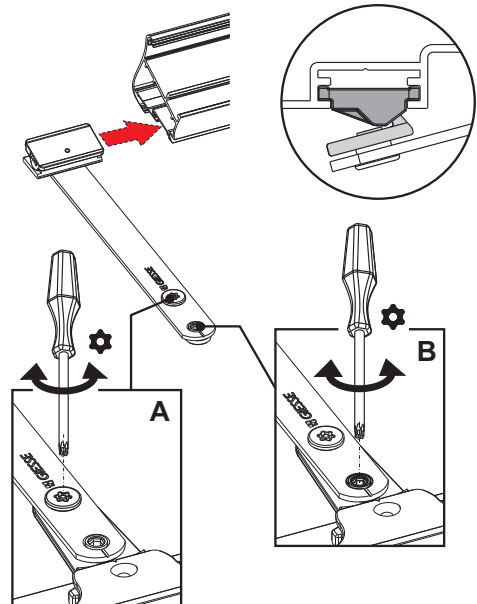
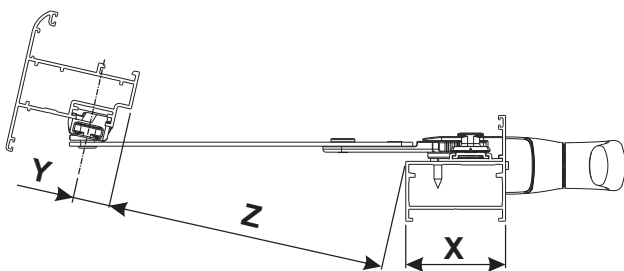

Item code	Description	Length	Slider material	Stack between profiles Z	Base Raw	Anodised Elox	Painted	Trend/Gold Brass	Pieces per pack
02064	ALUMINIUM OS OPERATOR ARM	172 mm	Aluminium	210 mm - X - Y	X				10
02065	ALUMINIUM OS OPERATOR ARM	152 mm	Aluminium	190 mm - X - Y	X				10

CONFIGURATION EXAMPLES

OS Operator Top-Hung Configuration

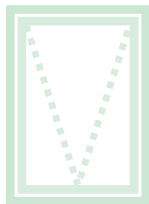

Sash height [mm]	450 ÷ 2000	450 ÷ 2000
Sash width [mm]	500 ÷ 800	801 ÷ 1500
Cremona	01128 - 01171	01128 - 01171
Mechanism	020021 - 020021	02000
Arms	02054 - 02055 - 02064 - 02065	02054 - 02055 - 02064 - 02065

OS Operator Side-Hung Configuration

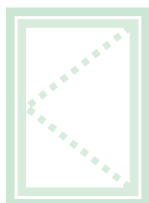

Sash height [mm]	450 ÷ 900	450 ÷ 900
Sash width [mm]	500 ÷ 800	801 ÷ 2500
Cremona	01128 - 01171	01128 - 01171
Mechanism	020021 - 020021	02000
Arms	02054 - 02055 - 02064 - 02065	02054 - 02055 - 02064 - 02065

OS OPERATOR 2.0

OS OPERATOR 2.0

Functions

Complete system of opening, closing and multilocking, for top hung and side hung outward opening casement windows.

Technical Features

The OS Operator 2.0 system to be applied requires a specific profile cross-section.

The front force for opening the sash must be $< 50\text{ N}$. For forces $> 35\text{ N}$ it is mandatory to use "loose rivet" arms.

The OS Operator System performs a dual function:

1. The sash is moved from the closed position to the open position, limited in safety.
2. The locking points engage and disengage.

With OS Operator 2.0 you can apply locking points connected by a rod made of polyamide, on 3 sides of the casement (mechanism side and arms side).

Making the OS Operator casement always requires:

- Cremone (1 pc)
- Mechanism (1 pc)
- Arm (1 pc)
- Locking points (their number varies depending on the size of the casement)
- Corner drive (2 pcs) if perimetral closing is necessary

Possible dimensions

In particular, the minimum size will vary depending on the locking points used (see examples)

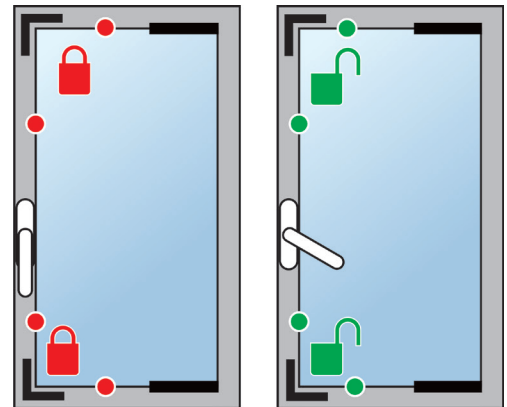
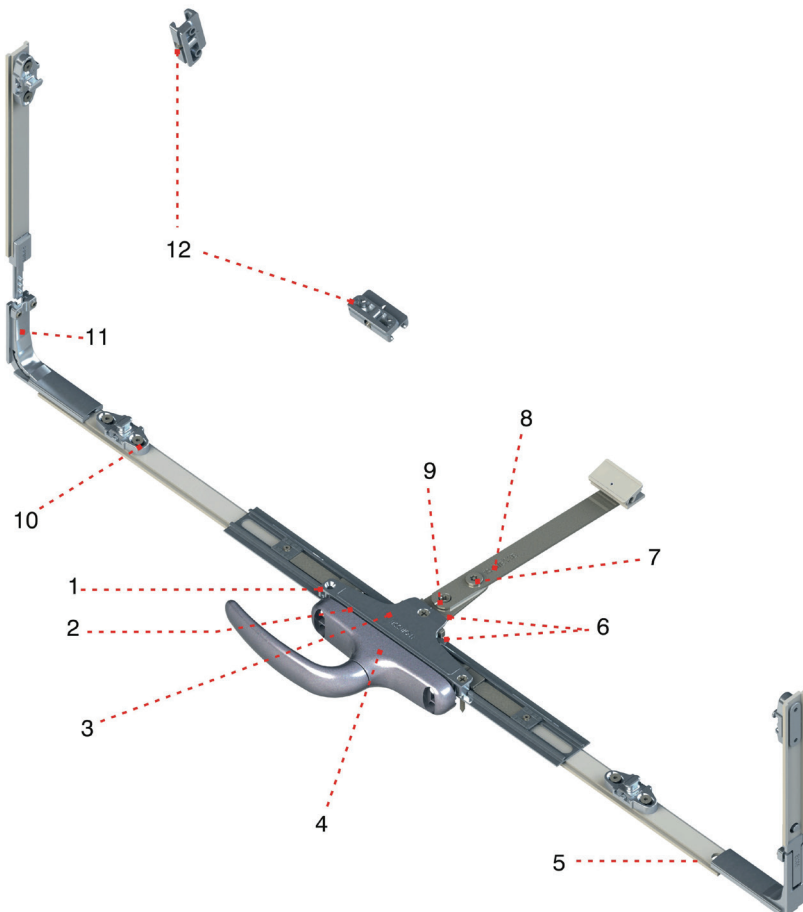

LEGEND

- 1 Basic mechanism
- 2 Unica cremone seal
- 3 Protective cover
- 4 Unica cremone
- 5 Polyamide rod
- 6 Mechanism gears
- 7 Arm release screw
- 8 Arm
- 9 Adjustment screws
- 10 Adjustable pawl (sash)
- 11 Corner drive
- 12 Fixed striker (frame)

OS OPERATOR 2 type profile cross-sections

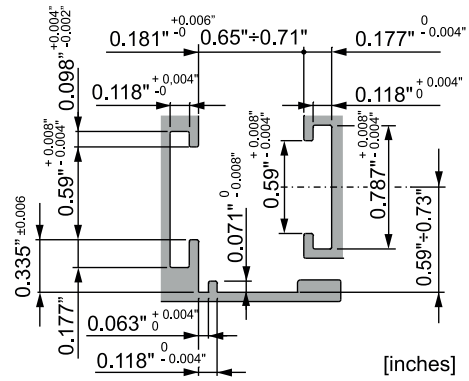
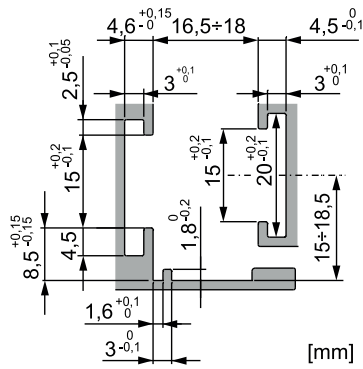

Minimum possible dimensions

Two locking points

Two locking points with corner drive

Four locking points with corner drive

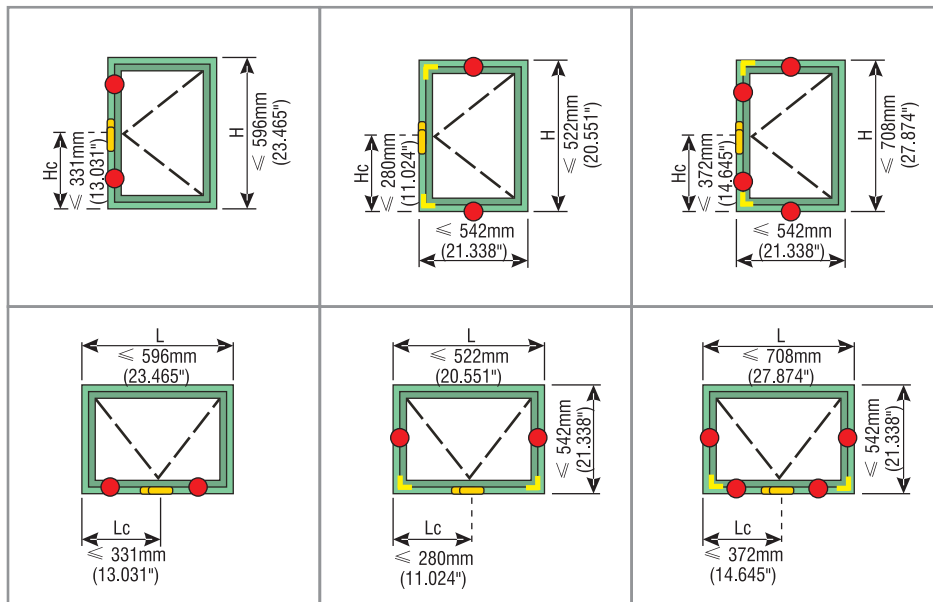

R = use Loose Rivet swing-out arms for supporting the sash

R = use Loose Rivet swing-out arms for supporting the sash

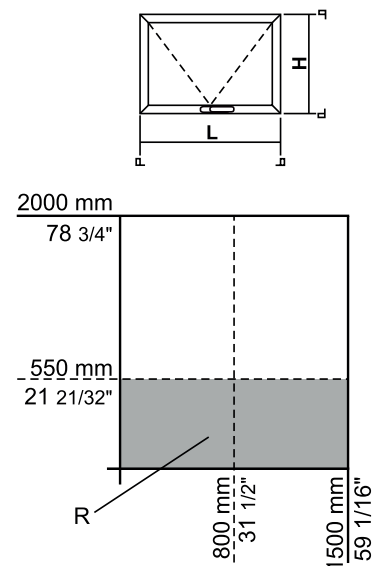
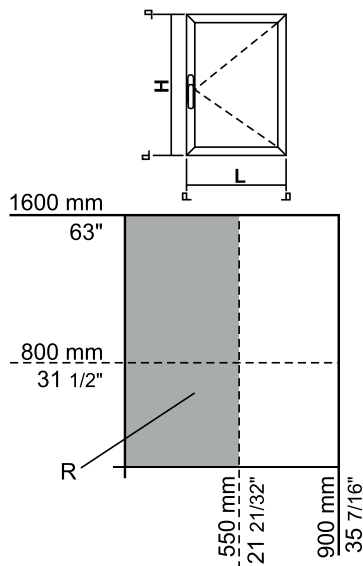



UNICA OS OPERATOR CREMONE

Functions

Unica line cremone, dedicated to the OS OPERATOR mechanism.

Online data sheet



Technical Features

Compared to the standard cremones, these rotate with positioning notches at 0° and 180°.

Turning the pull handle of the cremone to 180° first unlocks the locking points (approximately 60°) and then takes the sash into the position of maximum opening (trip to 180° of the cremone).

The high stresses to which the casement is subjected when opening and closing has meant that for OS Operator there is a complete range of specific cremones. In addition to the Unica standard cremone, Key, Away and long handle versions are available. In particular, the one with the long handle reduces the effort when opening the casement and makes operation smoother.

The rotor and slider of all OS operator cremones are made of stainless steel to ensure maximum mechanical strength.

It is recommended to use the special gasket, made of black closed-cell foam adhesive on one side, which enables reducing the flow of air and water through the milling on the profile and the cremone case.

Materials

Handle in die-cast aluminium

Die-cast zamak cremone case

Internal rotor and slider in 304 grade stainless steel

Spring in harmonic steel

Black polyamide plate

Trip disc 0° - 180° in black polyamide

Unica OS Operator Cremone

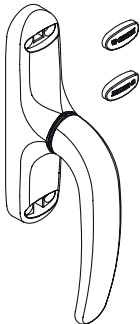

Unica Away OS Operator Cremone

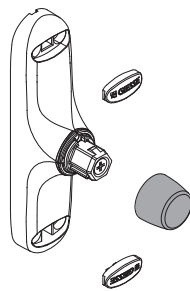

Long pull handle Unica OS Operator Cremone

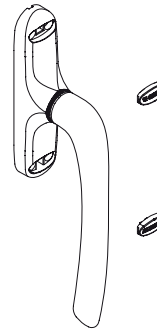

Unica Key OS Operator Cremone

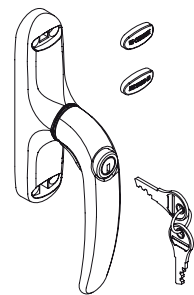

Item code	Description	Version	Pull handle length	Handle match	Pull handle 0°	Pull handle 180°	Base Raw	Anodised Elox	Painted	Trend/Gold Brass	Pieces per pack
01127	CREM. UNICA OS OPERATOR - AWAY	Away		01129	Closed	Open			X		10
01128	CREM. UNICA OS OPER. LONG HANDLE	Standard	172 mm		Closed	Open			X		10
01129	PULL HANDLE FOR UNICA AWAY	Away	172 mm	01127	Closed	Open			X		10
01171	UNICA OS OPERATOR CREMONE	Standard	121 mm		Closed	Open			X		10
01172	UNICA KEY OS OPERATOR CREMONE	Key	121 mm		Closed	Open			X		10
06951	UNICA CREM. GASKET						X				100

OS OPERATOR 2.0 MECHANISM

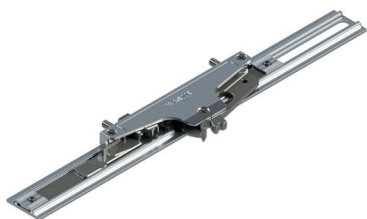
**Functions**

Reversible mechanism that moves the sash of a Top or Side Hung aluminium casement.

Online data sheet

**Technical Features**

The mechanism is 317 mm long.

Acts as a link between the cremone and the opening arms.

Connected to the Giesse polyamide rod, it is used to move the locking points (applied on the rod) and/or corner drives in the case of perimetral closing mechanisms.

Materials

Main body (guide), made of extruded aluminium, silver anodised

Internal rod, in extruded aluminium, silver anodised

Pinion, in 304 grade stainless steel

Rack drive rod, in 304 grade stainless steel

Casing, in Giesse Silver Plus zamak

Fixing screws in 304 grade stainless steel

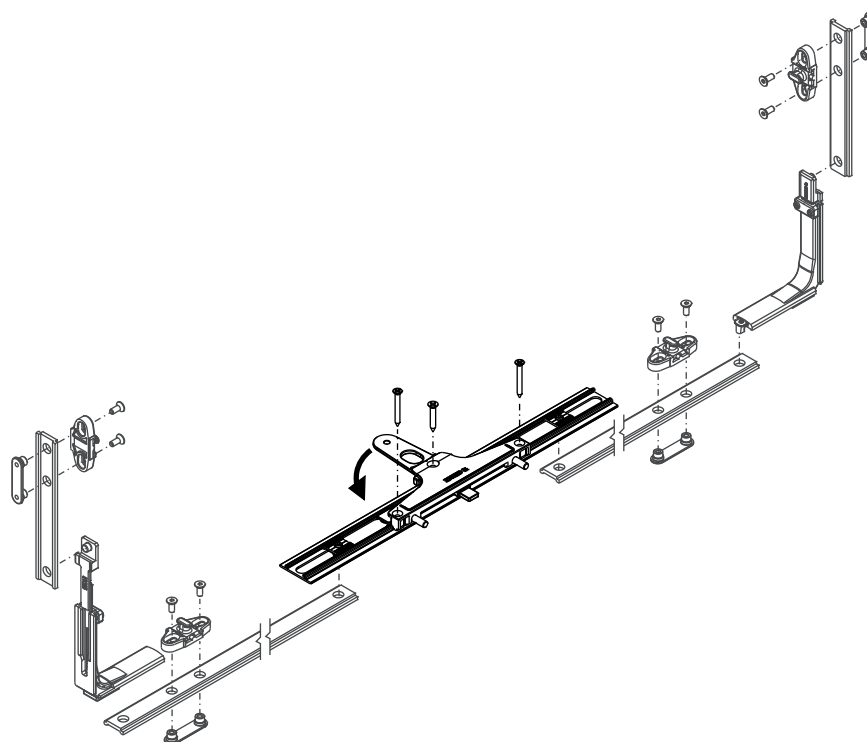
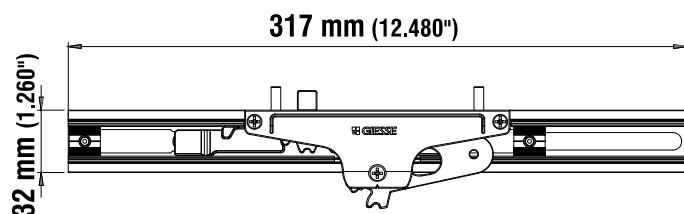

Item code	Description	Note	Base Raw	Anodised Elox	Painted	Trend/Gold Brass	Pieces per pack
02009	OS OPERATOR MECHANISM		X				10

OS OPERATOR 2 ARMS

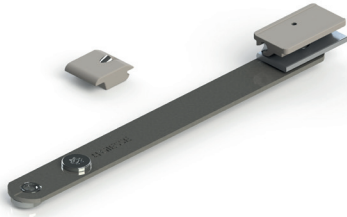

Functions

The arm for OS Operator performs the function of pushing the sash from the "sash closed" position to the "fully open" position and vice versa.

Online data sheet



Technical Features

Available in various lengths), the arm is attached to an OS Operator mechanism using the screw with security head Torx T30 (A). The slider, available in both polyamide and aluminium, runs in the 15/20 mm channel on the mobile sash. A polyamide stop component provides the limit stop position.

You can, with the aid of the eccentric pin (B), using a T30 torx wrench, adjust the position of the slider and then obtain the optimal position for the sash during the phase of activating the locking points.

Materials

Arm in stainless steel 304
Slider in extruded aluminium or grey polyamide
Grey polyamide stop

L = Length (see table)

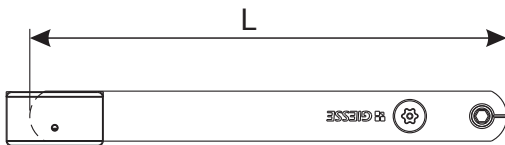

Z = Distance between the profiles (see table)

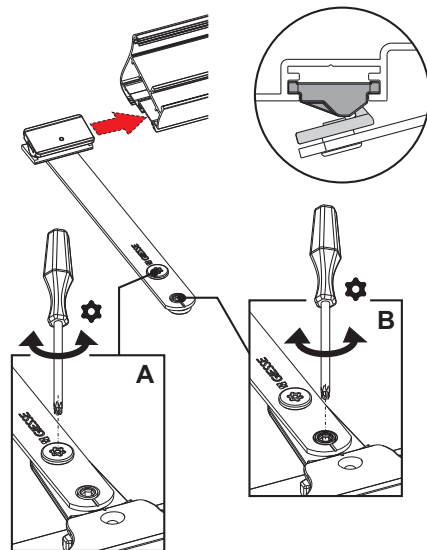
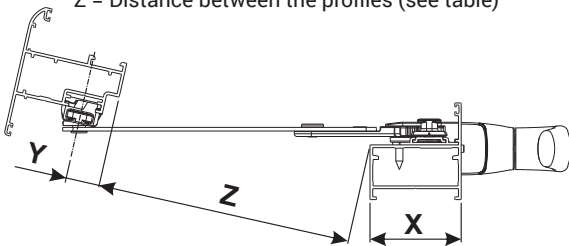

Item code	Description	Length	Slider material	Stack between profiles Z	Base Raw	Anodised Elox	Painted	Trend/Gold Brass	Pieces per pack
02056	OS OPERATOR HP ARM	172 mm	Aluminium	210 mm - X - Y	X				10
02058	OS OPERATOR HP ARM	146 mm	Aluminium	184 mm - X - Y	X				10
02059	OS OPERATOR HP ARM	127 mm	Aluminium	165 mm - X - Y	X				10
02061	OS OPERATOR HP ARM	140 mm	Aluminium	178 mm - X - Y	X				10
02064	ALUMINIUM OS OPERATOR ARM	172 mm	Aluminium	210 mm - X - Y	X				10
02065	ALUMINIUM OS OPERATOR ARM	152 mm	Aluminium	190 mm - X - Y	X				10

OS OPERATOR CORNER DRIVE



Functions

Component allowing the mechanism to move from the cross-beam to the upright of the casement and vice versa.

Online data sheet



Technical features

Specific for fitting on the frame.

Fits on 15/20 channel.

It is installed after machining the frame or before the frame is assembled.

It is fixed with 2 contrast grub screws and is joined to the other components with a polyamide rod.

Materials

Drive body and connection device made of Giesse Silver Plus

Plates and grub screws in stainless steel

Inserting in channel

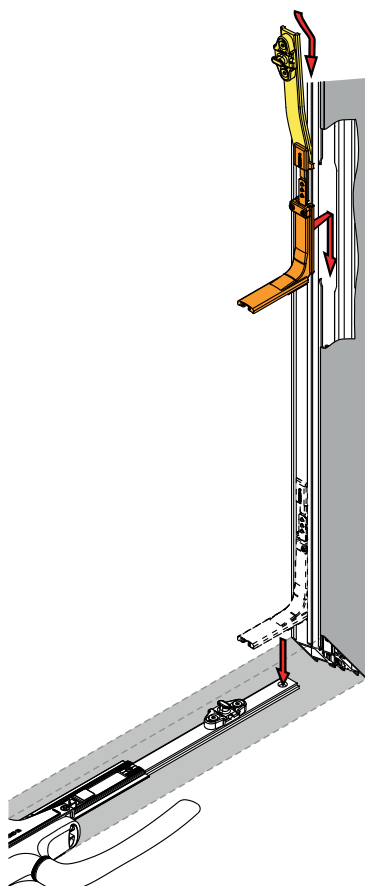

Machining

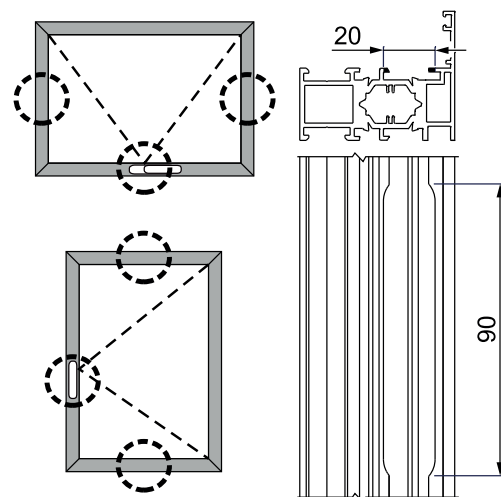

Item code	Description	Note	Base Raw	Anodised Elox	Painted	Trend/Gold Brass	Pieces per pack
02066	CORNER DRIVE		X				10

OS OPERATOR FASTENING MECHANISM KIT



Functions

Fastening mechanism kit composed of a striker and an adjustable pawl.

Online data sheet



Technical features

The OS Operator 2.0 closing kit is composed of 2 components:

- Striker to be applied on the sash
- Adjustable pawl to apply on the polyamide rod

The system provides for an adjustment of ± 3.2 mm and laterally ± 3.0 mm with the aid of the pawl.

The system is designed for at most 6 locking points.

Materials

Striker body, pawl body, plate and adjustable element made of Giesse Silver Plus zamak
Screws and grub screws in stainless steel

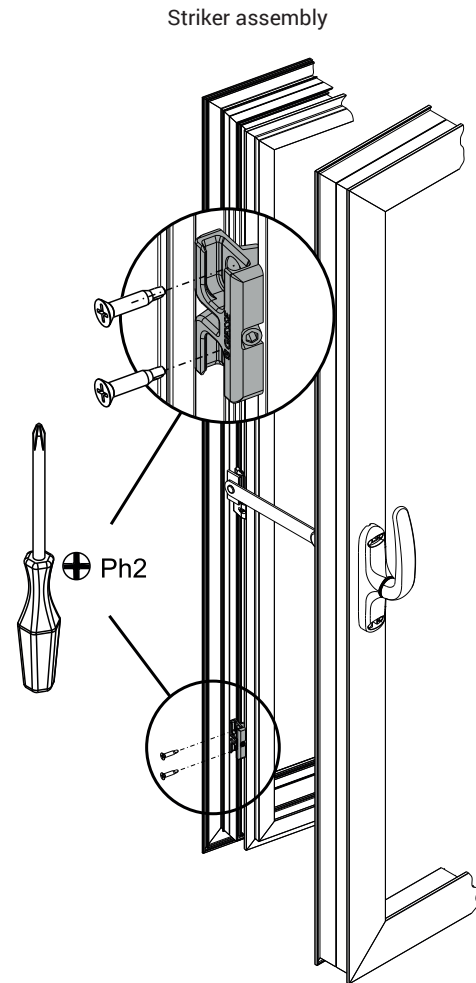
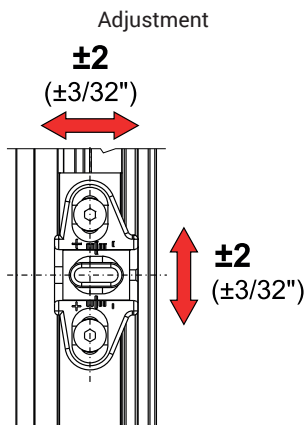
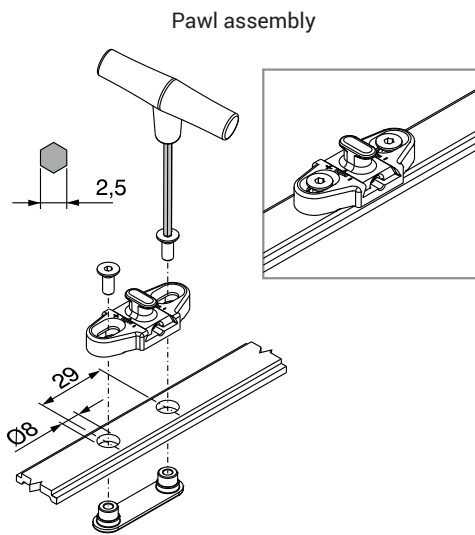

Item code	Description	Note	Base Raw	Anodised Elox	Painted	Trend/Gold Brass	Pieces per pack
02067	LOCKING POINT		X				10

OS OPERATOR 2.0 TOOLS

Functions

Tool kit for correctly assembling the Os Operator

[Online data sheet](#)



Technical Features

The kit includes all the necessary tools, especially the Torx T30 security wrench.

The kit consists of:

- Allen wrench 2.5 mm and 3 mm
- Torx T30 security insert
- ph 2 insert

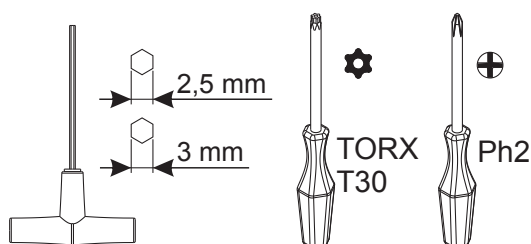

Item code	Description	Note	Base Raw	Anodised Elox	Painted	Trend/Gold Brass	Pieces per pack
02003	TOOL KIT FOR OS OPERATOR		X				20

CONFIGURATION EXAMPLES

Configuration of OS Operator 2.0 Top-Hung 2 locking points

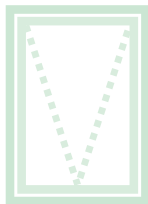

Sash height [mm]	450 ÷ 2000
Sash width [mm]	596 ÷ 1500
Cremona	01128 - 01171
Mechanism	02009
Fastening mechanisms	02067 (2 pcs)
Arms	02054 - 02055 - 02064 - 02065

Configuration of OS Operator 2.0 Top-Hung 4 locking points

Sash height [mm]	542 ÷ 2000
Sash width [mm]	708 ÷ 1500
Cremona	01128 - 01171
Mechanism	02009
Drive	02066 (2 pcs)
Fastening mechanisms	02067 (4 pcs)
Arms	02054 - 02055 - 02064 - 02065

Configuration of OS Operator 2.0 Side-Hung 2 locking points

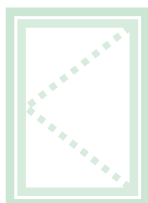

Sash height [mm]	596 ÷ 1600
Sash width [mm]	450 ÷ 900
Cremona	01128 - 01171
Mechanism	02009
Fastening mechanisms	02067 (2 pcs)
Arms	02054 - 02055 - 02064 - 02065

Configuration of OS Operator 2.0 Side-Hung 4 locking points

Sash height [mm]	704 ÷ 1600
Sash width [mm]	450 ÷ 900
Cremona	01128 - 01171
Mechanism	02009
Drive	02066 (2 pcs)
Fastening mechanisms	02067 (4 pcs)
Arms	02054 - 02055 - 02064 - 02065

JALOUSIE

Functions

Opening system for Jalousie casements featuring a fixed frame on which are mounted cremone adjustable slats.

Jalousie windows are ideal for verandas, terraces and other places where the user wishes to be able to ventilate the interior without opening the window.

Technical Features

The system consists of a set of accessories that combined together enable operating the adjustable slats.

The window slats can be in aluminium or glass, depending on the application. Up to 6 can be moved with the cremone. For casements with more than 6 slats you need to use 2 cremones.

Components of the system (in the case of 6 slats)

- UNICA Cremone (no. 1 pc)
- Cam (no. 12 pcs)
- Slat container (no. 6 pcs)
- Pack screw (no. 12 pcs)
- Transmission pin (no. 12 pcs)

The cremone handle can be set to adjust the slats to fully closed, ventilation, or fully open.

- Cremone 0° - Slats closed
- Cremone 90° - Slats open in ventilation position
- Cremone 180° - Slats fully open

Possible dimensions

- Maximum glass thickness 6 mm
- Maximum distance between slats 90 mm
- Maximum sash width 700 mm

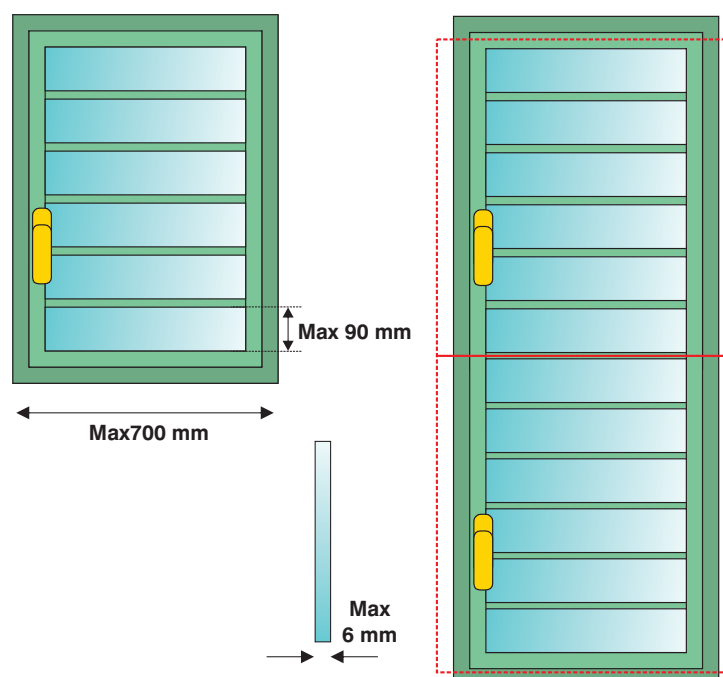
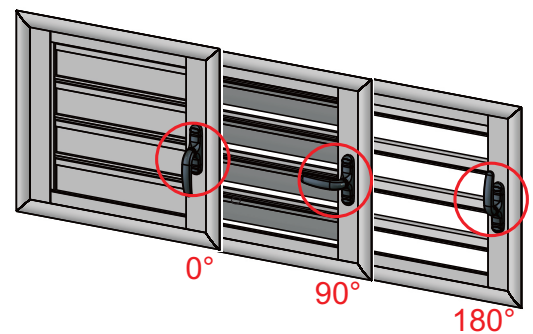



UNICA CREMONE FOR JALOUSIE

Functions

Specific Cremone for the Jalousie system.

[Online data sheet](#)



Technical Features

Controls opening the slats that depending on the position of the pull handle may be in the closed, ventilation or fully open position.

Materials

Handle in die-cast aluminium
Case, gear and sliding parts in zinc plated zamak
Polyamide plate
Stainless steel fixing screws

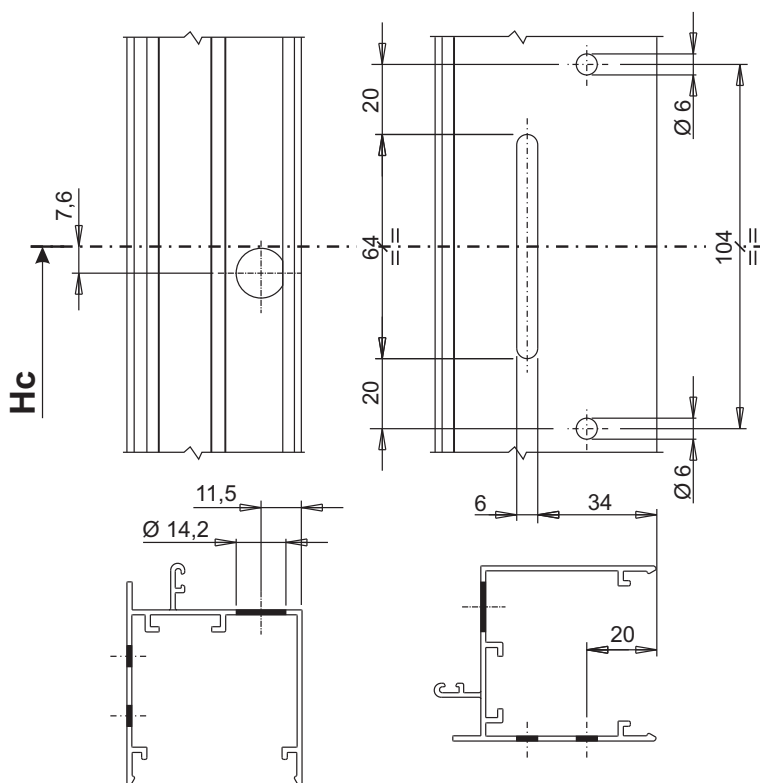
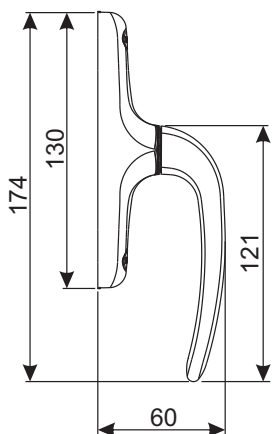

Item code	Description	Operation	Base Raw	Anodised Elox	Painted	Trend/Gold Brass	Pieces per pack
01987	UNICA CREMONE FOR JALOUSIE	one-way			X		10

JALOUSIE COMPONENTS

Functions

Operated by the Unica Cremone, the Jalousie components enable operating the hardware and opening and closing the slats.

Online data sheet



Technical Features

The system must be connected with an aluminium rod for the European groove and is composed of:

1 - Cam

Connected to the rod via the transmission pins it allows the slats to move. Made of punched aluminium.

2 - Slat container (pair)

Sized to accommodate the swivel slat. Blocks in black painted die-cast zamak and washers in black polyamide.

3 - Slat-cam packing screw

Enables fixing together the cam and the slat container. Made of stainless steel.

4 - Transmission pin

It transmits the movement from the cremone to the connection rod and to the cam. Made of stainless steel.

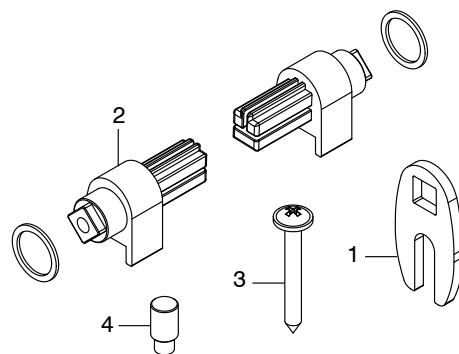
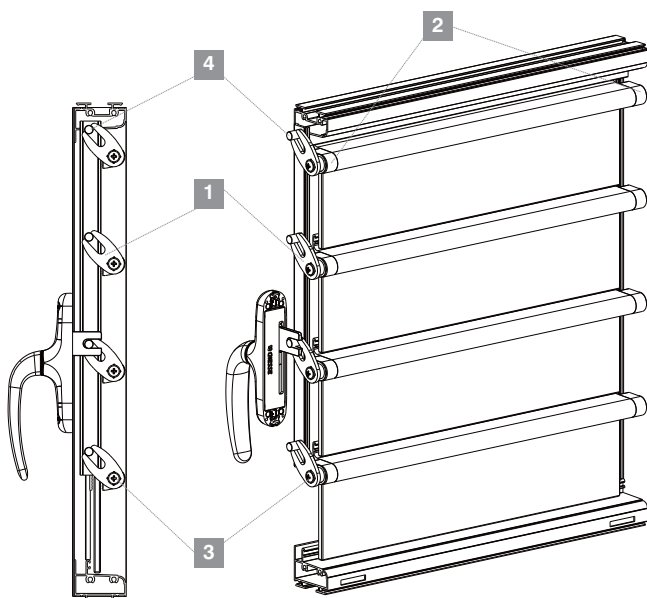

Item code	Description	Note	Base Raw	Anodised Elox	Painted	Trend/Gold Brass	Pieces per pack
01984	CAM FOR JALOUSIE SYSTEM (1)		X				100
01985	SLAT CONTAINER (RIGHT AND LEFT) (2)	pair			X		100
01986	SLAT-CAM PACKING SCREW (3)		X				100
01988	DRIVE PIN (4)		X				100

CONFIGURATION EXAMPLE

Jalousie Configuration (max. 6 slats)



Maximum sash width [mm]	700	-
Cremone	01987	N° 1
Cam	01984	N° 12
Slat container	01985	N° 6
Screw	01986	N° 12
Drive pin	01988	N° 12

PROVENCE

Functions

Fastening system with cremone and rods with front fixing, designed for making fastening mechanisms for inward or outward opening casement windows, applicable on profiles of any material, aluminium, wood, PVC.

Technical Features

Provence is ideal for creating old-style windows, thanks to its careful design featuring rods in full view.

Applicable on both inward-opening and outward-opening casements:

- Inward opening casement: flush and overlap (7-10 mm)
- Outward opening casement: both with and without frame, flush inside and overlap (7-10 mm).

Making a casement with PROVENCE requires:

- Cremone (1 pc)
- Lock rod (2 pcs)
- Bolt tips (2 pcs)
- Strikers (2 pcs)

All the elements are revealed and specific to this system.



Inward opening with overlap

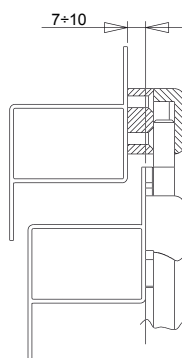

Flush inward opening

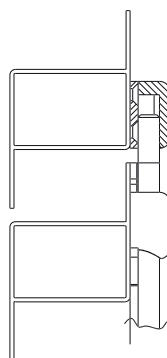

Outward opening casement with overlap

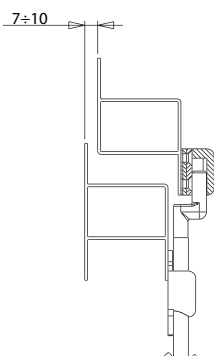

Flush outward opening casement

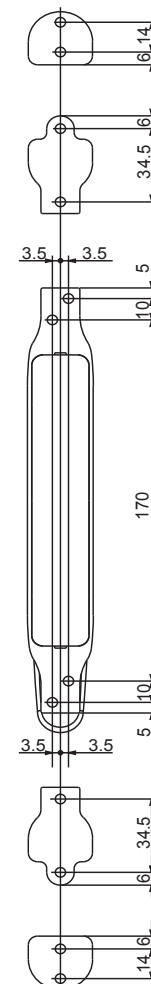
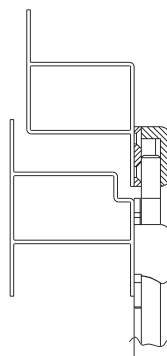

PROVENCE CREMONE

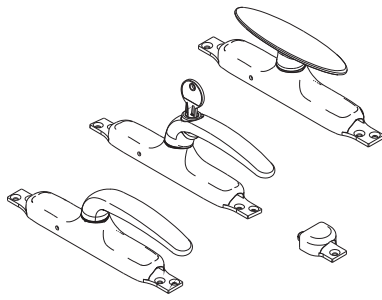

Functions

Lever Cremone, reversible, with closing rods in view, for front mounting for windows and shutters

Online data sheet



Technical Features

Front fixing with self-tapping screws.
 All the fixing screws are concealed to enhance the design of the cremone and of the entire fastening mechanism.
 The necessary machining consists of just holes with a single drill bit (Ø2.7mm in the case of aluminium). We recommend using the dedicated template.
 Provence has a stroke of 18 mm, which allows an effective grip in the wall or in its strikers. The cremone package includes two rod guides and two pins for connection with the locking rods.

Materials

Handle in die-cast aluminium
 Cremone case, gear, racks and rod guide in die-cast zamak
 Trip spring, screws and grub screw, pre-assembled, in stainless steel
 Liners in white polyamide
 Extruded aluminium rod connecting blocks
 Rod connection terminal and fixing screws in zinc plated steel

Lever pull handle Provence Cremone

Provence Cremone, lever pull handle with key

"T" pull handle Provence Cremone

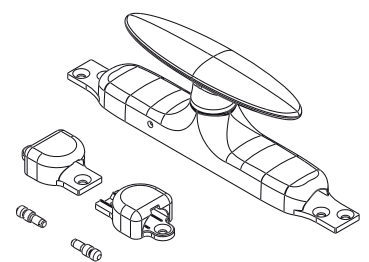
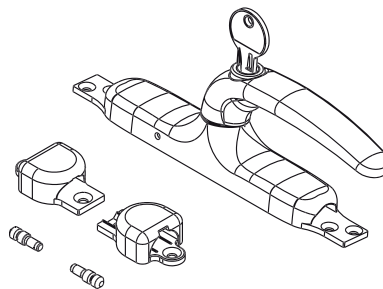
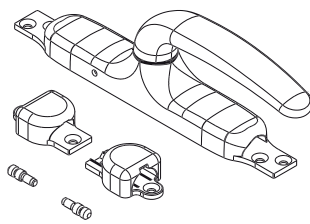
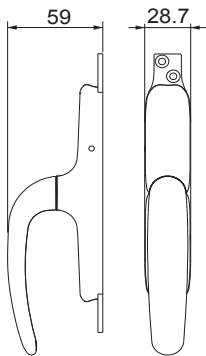

Item code	Description	Version	Pull handle	Base Raw	Anodised Elox	Painted	Trend/Gold Brass	Pieces per pack
01160	LEVER PULL HANDLE PROVENCE CREMONE		Unica	X		X		10
01161	PROVENCE CREMONE, LEVER/KEY PULL HANDLE	Key	Unica	X		X		10
01162	T PULL HANDLE PROVENCE CREMONE		T	X		X		10

RODS

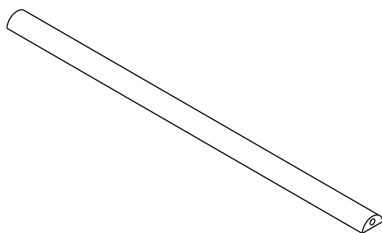

Functions

Connection rod in view for closing the Provence Cremone.

Online data sheet



Technical Features

They are available in different lengths, to be cut to size on the basis of the position of the Cremone and the dimensions of the sash.

At its ends you are to add the pin for connecting to the Cremone (included with the latter) and the fastening bolt tip, to be ordered separately.

Rod Guide

Additional element to be ordered separately if the casement is particularly large and you want to prevent the risk of the rod flexing.

Recommended for use near the third fastener, if fitted, in order to strengthen it.

Rod guide in die-cast zamak.

Zinc plated steel screws.

Clearance reduction element made of polyamide.

Materials

Extruded aluminium

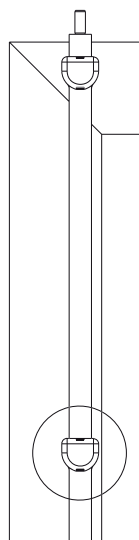
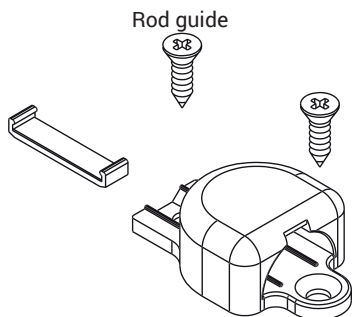

Item code	Description	Length	Base Raw	Anodised Etiox	Painted	Trend/Gold Brass	Pieces per pack
01297	PROVENCE FASTENING MECHANISM ROD	1600 mm	X		X		10
01298	PROVENCE ROD GUIDE		X		X		10
01300	PROVENCE FASTENING MECHANISM ROD	1000 mm	X		X		10
01304	PROVENCE FASTENING MECHANISM ROD	1250 mm	X		X		10

PROVENCE BOLT TIPS

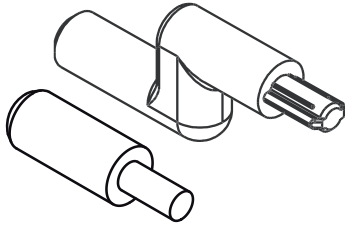

Functions

Straight terminals for top and bottom closing of the Provence cremone

Online data sheet



Technical Features

Available in two versions, straight and offset.

The straight terminal is used in all flush situations or when combined with strikers with a plate and their shims that always go into flush conditions.

The offset terminal is used when there is an overlap between the sash and frame.

They are engaged at the end of the rod, with a hammer, with the aid of the specific kit that has the purpose of preventing the hammer from accidentally chipping the surface finish of the rods or blocks of the third fastening mechanisms.

Materials

Stainless Steel

Straight terminal

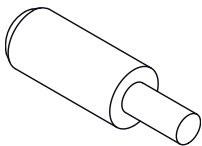

Offset terminal

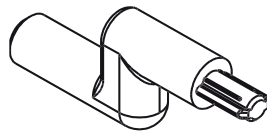

Provence bolt tip insertion kit

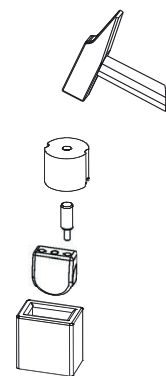
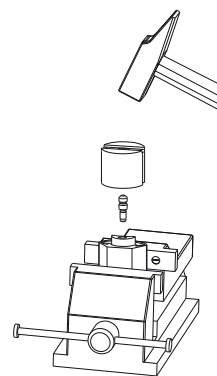
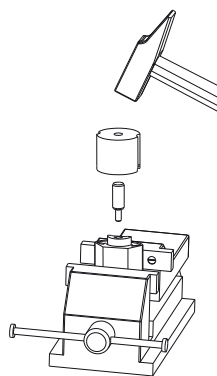
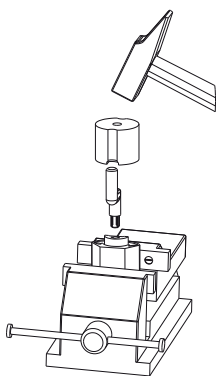
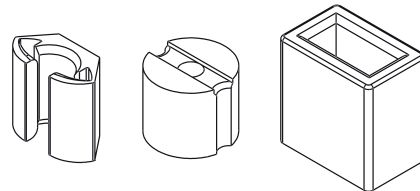

Item code	Description	Offset terminal	Opening	Base Raw	Anodised Elox	Painted	Trend/Gold Brass	Pieces per pack
02135	PROVENCE STRAIGHT TERMINAL	NO	External / Internal	X				20
02136	PROVENCE OFFSET TERMINAL	YES	External	X				20
03288	PROVENCE BOLT TIP INSERTION KIT			X				50

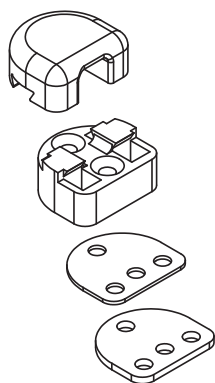

PROVENCE STRIKERS

Functions

Strikers for closing the Provence cremone

Online data sheet



Technical Features

It is fitted on the frame and intercepts the bolt tip applied on the aluminium rod, which is moved by the cremone. Both models are for an overlap of 7 mm, but with shims they can go up to 10 mm.

With the Provence strikers it is possible to have fasteners on both inward-opening and outward-opening casements (flush and overlap).

Materials

Die-cast zamak plate and casing
Polyamide shims
Zinc plated steel screws.

Inward opening striker

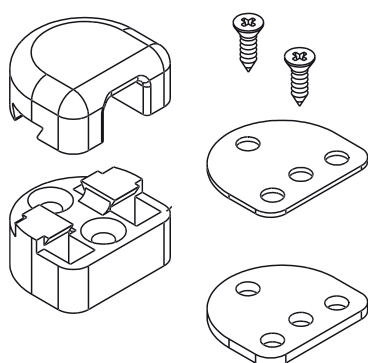

Outward opening casement striker

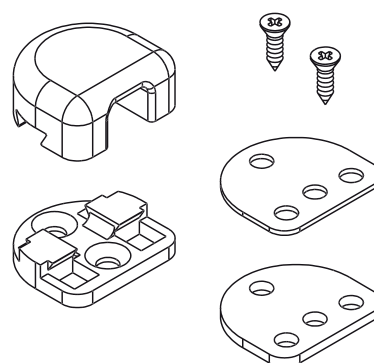

Item code	Description	Step	Overlap Inward Opening	Flush Inward Opening	Overlap Outward Opening	Flush Outward Opening	Base Raw	Anodised Elox	Painted	Trend/Gold Brass	Pieces per pack
01294N	PROVENCE STRIKER	7 ÷ 10 mm	x				X		X		20
01295N	PROVENCE STRIKER	7 ÷ 10 mm		x	x	x	X		X		20

CONFIGURATION EXAMPLES

Inward opening Provence configuration

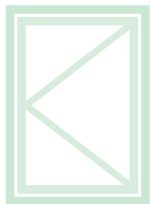

Profile type	Overlap	Flush
Cremone	01160 - 01161 - 01162	01160 - 01161 - 01162
Rod	01297 - 01300 - 01304	01297 - 01300 - 01304
Bolt tip	02135	02135
Striker	01294N	01295N

Outward opening casement Provence configuration

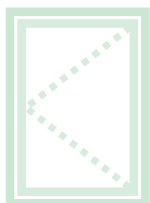

Profile type	Overlap	Flush
Cremone	01160 - 01161 - 01162	01160 - 01161 - 01162
Rod	01297 - 01300 - 01304	01297 - 01300 - 01304
Bolt tip	02136	02135
Striker	01295N	01295N



CDM 30

Functions

Remote manual control for opening bottom-hung casements of maximum width 1200 mm, composed of scissor, corner drive, articulated handle.

Online data sheet



Technical Features

The manual bottom-hung opening CDM30 is formed by:

- control for bottom-hung windows including manual lever, main scissor and chain corner drive;
- transmission rod;
- casing;

The scissor of the CDM30 control allows the maximum opening of 180 mm. The CDM30 control is applicable on all casements with a minimum height of 250 mm and a maximum weight of 80 kg.

The corner drive uses a chain and ensures sturdiness and functionality over time. The scissor of the CDM30 control enables quickly locking and releasing the sash with a lug, and you can also adjust the pressure of the sash with the mechanism installed.

The CDM30 control is applicable on flush or stepped profiles from 0 to 25 mm.

Additional fastening mechanisms

For sashes of width greater than 1200 mm, it is necessary to use one or more additional scissors. Using additional scissors does not increase the load capacity that remains at 80 kg max.

Materials

Control for bottom-hung windows and additional scissor made of extruded aluminium, stainless steel and zamak.

Polyamide caps.

Driving rod made of stainless steel.

Extruded aluminium casing.

Types and load capacities

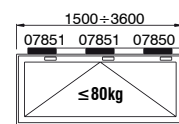
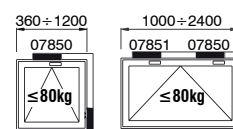

Bottom-hung windows control

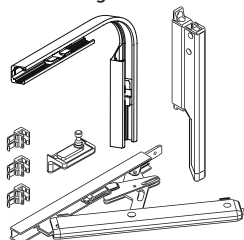

Driving rod

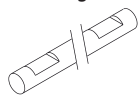

Protective cover

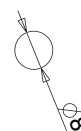
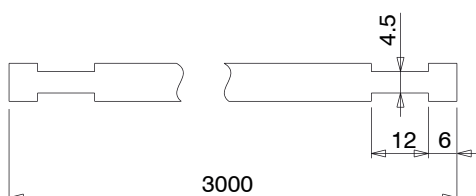
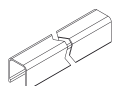

Additional scissor

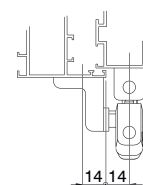
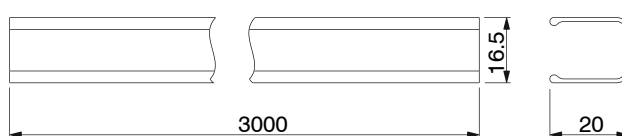
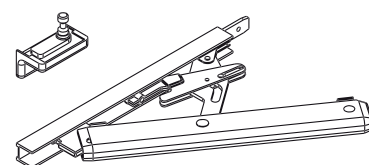

Codes	Description	Length (mm)	Base Raw	Anodised Elox	Painted	Trend/Gold Brass	Pieces per pack
07850	BOTTOM-HUNG WINDOWS CONTROL CDM30	-		X	X		1
07851	ADDITIONAL SCISSOR	> 1200		X	X		1
07852	DRIVING ROD	3000	X				1
07853	PROTECTIVE COVER	3000		X	X		1

 **GIESSE**



**MECHANISMS
AND KITS FOR
TILT-AND-TURN**

CHIC 3D 100

Functions

Complete system for the construction of concealed tilt-and-turn windows with load capacities of up to 100 kg and with 180° sash opening. Available in the standard, logic and micro-ventilation versions.

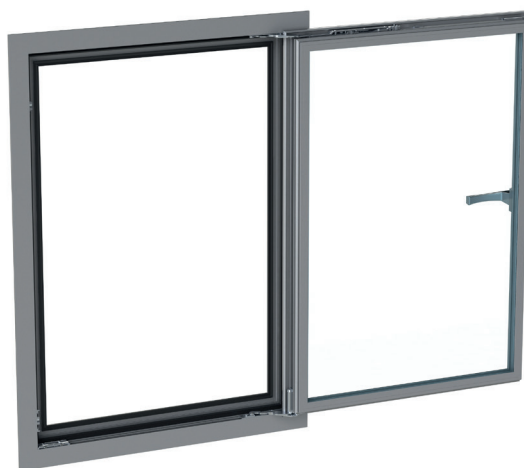

CHIC 100

Technical Features

Making a CHIC 3D 100 Tilt-and-Turn mechanism requires:

1. Set of hinges + arms
2. Set of mechanisms for cremones, window handles and NP SUPRA window handles
3. Cremone, window handle or NP SUPRA window handle (available in different models to choose from in the specific catalogue section)

Adjustments

The adjustments are micrometric and independent.

Standard microventilation

Micro-ventilation enables having simultaneously both the tilt-and-turn position and micro-ventilation (precision opening of the sash) on the casement, for better air exchange.

Logica

The logical operation consists in first tilt-and-turn opening (with the cremone at 90°) and secondly side-hung opening (with the cremone at 180°). Its use is particularly recommended in public buildings (schools, hospitals, etc.) in combination with a cremone with a key in order to have only tilt-and-turn window opening for safety reasons and to allow full opening only for staff with the key.

Production micro-ventilation with standard opening

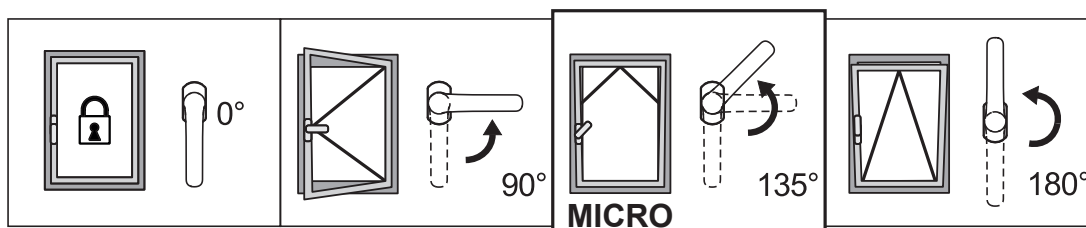

Production micro-ventilation with Logica opening

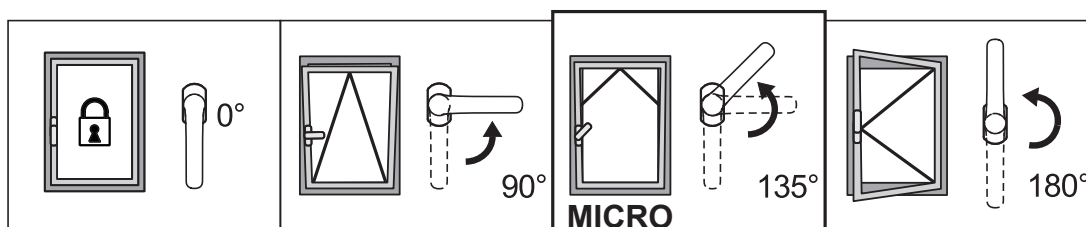

ADJUSTMENTS [mm]

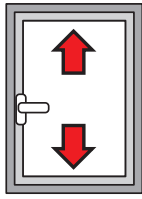

Height:
+2.5 / -1

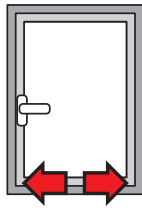

Side:
±1.5

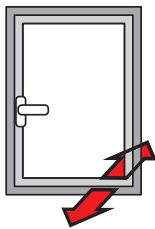

Bottom hinge compression:
+1.4 / -0.6

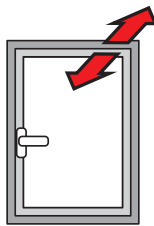

Top hinge compression:
±1.5

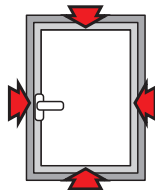

Striker compression:
±1.8

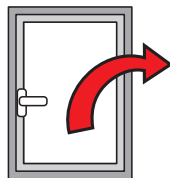

Sash fall:
+3.5 / -1.5

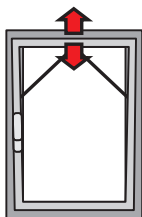

Micro-ventilation:
+3.6 / -1.8

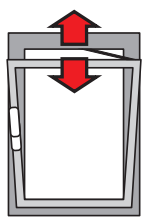

T2 arm opening:
148 ÷ 178

Table of maximum glass thickness [mm]

2500	33	27	23	20	18	16	15	14	13	12	11	
2400	33	27	23	20	18	16	15	14	13	12	11	
2300	34	28	24	21	19	17	16	14	13	12	11	
2200	36	30	25	22	20	18	16	15	14	13	12	
2100	37	31	27	23	21	19	17	16	14	13	12	
2000	39	33	28	25	22	20	18	16	15	14	13	
1900	41	34	30	26	23	21	19	17	16	15	14	
1800	44	36	31	27	24	22	20	18	17	16	15	
1700	46	38	33	29	26	23	21	19	18	16	15	
1600	49	41	35	31	27	25	22	20	19	17	15	
1500	50	44	37	33	29	26	24	22	20	17	15	
1400	50	47	40	35	31	28	25	23	20	17	15	
1300	50	50	43	38	34	30	27	24	20	17	15	
1200	50	50	47	41	36	33	28	24	20	17	15	
1100	50	50	50	45	40	34	28	24	20	17		
1000	50	50	50	49	42	34	28	24	20			
900	50	50	50	50	42	34	28	24				
800	50	50	50	50	42	34	28					
700	50	50	50	50	42	34						
600	445	500	600	700	800	900	1000	1100	1200	1300	1400	1500

Table of maximum load capacity [kg]

2500	100	100	100	100	100	100	100	100	100	100	100	100
2400	100	100	100	100	100	100	100	100	100	100	100	100
2300	100	100	100	100	100	100	100	100	100	100	100	100
2200	100	100	100	100	100	100	100	100	100	100	100	100
2100	100	100	100	100	100	100	100	100	100	100	100	100
2000	100	100	100	100	100	100	100	100	100	100	100	100
1900	100	100	100	100	100	100	100	100	100	100	100	100
1800	100	100	100	100	100	100	100	100	100	100	100	100
1700	100	100	100	100	100	100	100	100	100	100	100	98
1600	100	100	100	100	100	100	100	100	100	100	99	92
1500	100	100	100	100	100	100	100	100	100	100	93	87
1400	100	100	100	100	100	100	100	100	93	87	81	81
1300	100	100	100	100	100	100	100	94	87	80	75	75
1200	100	100	100	100	100	100	95	87	80	74	69	69
1100	100	100	100	100	100	95	87	79	73	68		
1000	100	100	100	100	96	87	79	72	67			
900	100	100	100	98	87	78	71	65				
800	100	100	99	87	77	69	63					
700	100	100	87	76	67	61						
600	445	500	600	700	800	900	1000	1100	1200	1300	1400	1500

CHIC 100

CHIC 3D 100 standard

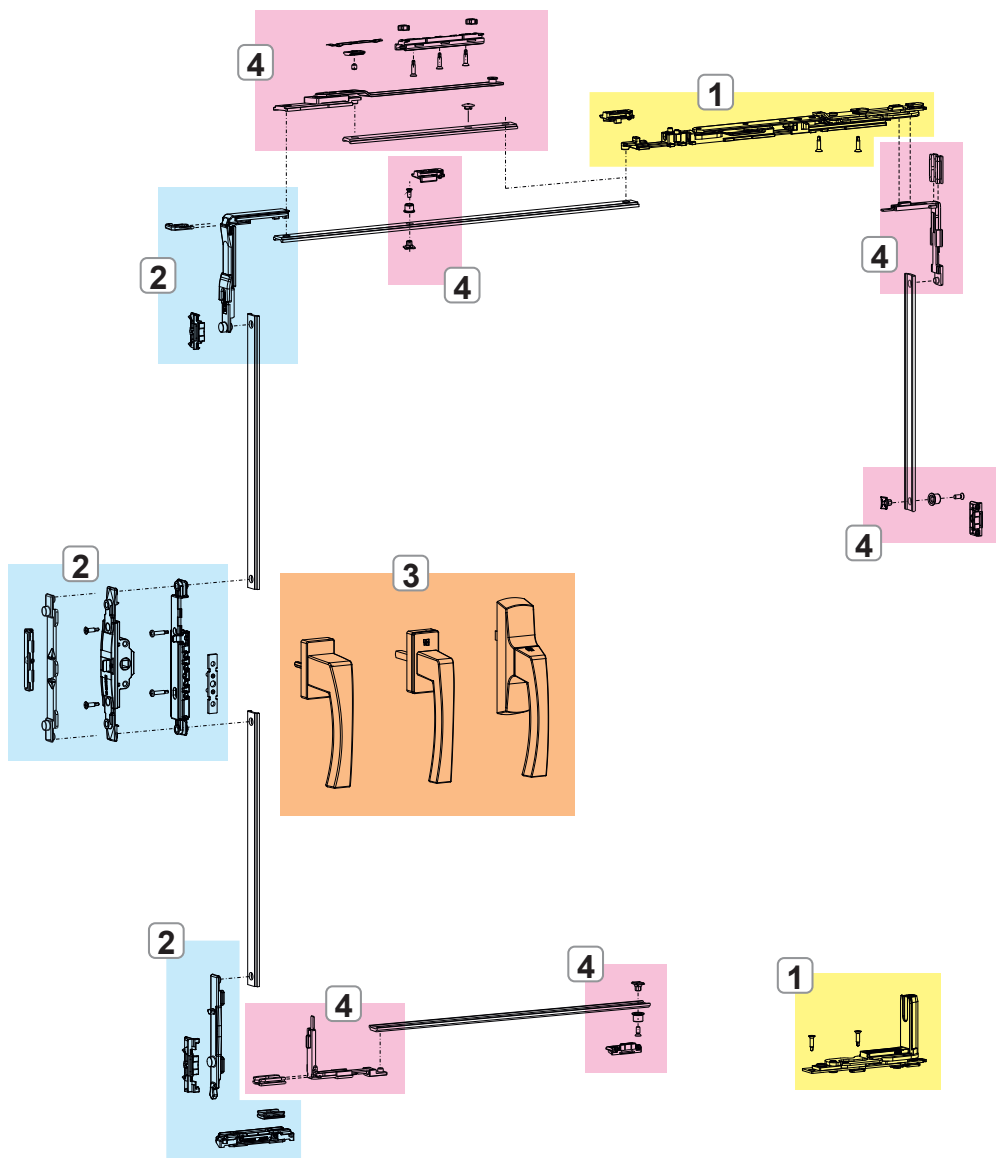

- 1. CHIC 3D 100 HINGES AND ARMS
- 2. CHIC 3D 100 FASTENING MECHANISMS
- 3. NP SUPRA CREMONES, WINDOW HANDLES AND MECHANISMS
- 4. CHIC 3D 100 ADDITIONAL FASTENING MECHANISMS AND HARDWARE

CHIC 100

CHIC 3D 100 logica

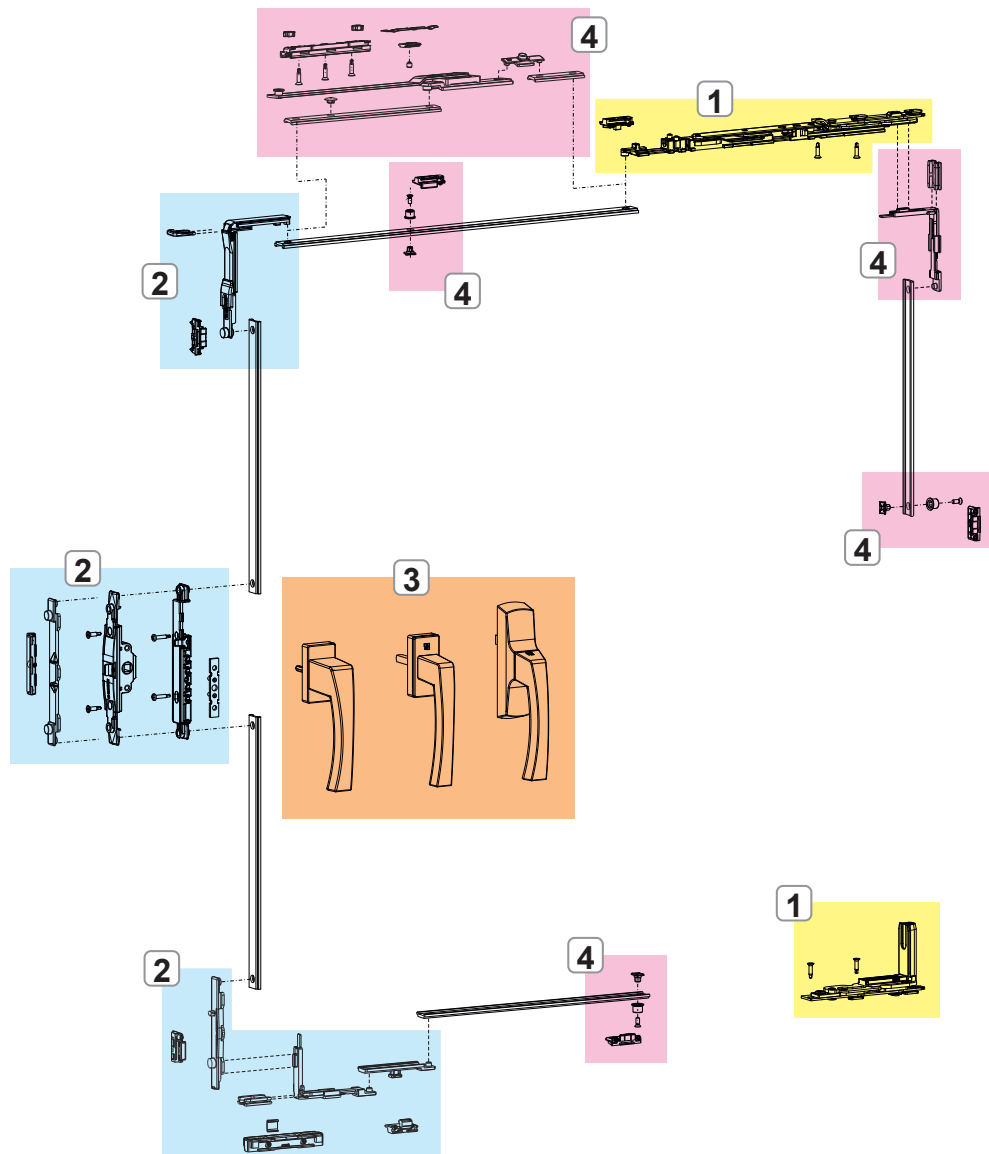

1. CHIC 3D 100 HINGES AND ARMS
2. CHIC 3D 100 FASTENING MECHANISMS
3. NP SUPRA CREMONES, WINDOW HANDLES AND MECHANISMS
4. CHIC 3D 100 ADDITIONAL FASTENING MECHANISMS AND HARDWARE

CHIC 3D 100 HINGES AND ARMS

Functions

Set of hinges (top and bottom), completely pre-assembled and ready to be installed on the profile.

Technical Features

They enable tilt-and-turn opening combined with the mechanisms.

Micro-ventilation and logica versions.

The arm is equipped with micro-ventilation as standard (adjustable).

Moving the fastening pawl takes the arm from conventional to logica.

The T2 arm is adjustable: the opening "A" goes from 178 mm (base) to 148 mm.

Materials

Corner support made of zamak

Connecting brackets and hinge plates made of zinc plated steel

Pins made of 304 grade stainless steel and aluminium bronze

Cams made of zinc plated steel

Connecting bracket and arm rod made of 304 grade stainless steel

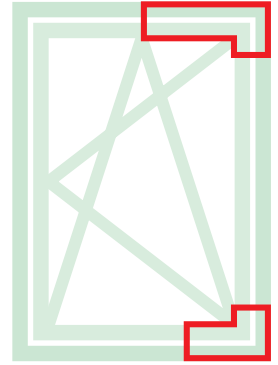

[Online data sheet](#)

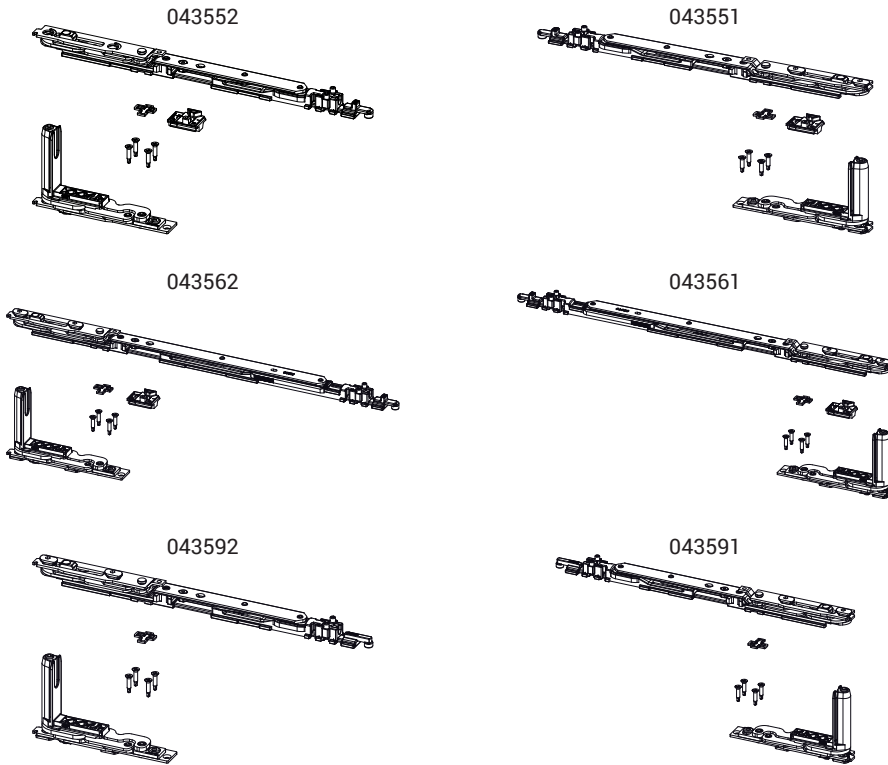

Sash opening

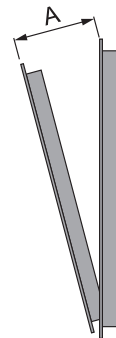

Item code	Description	PROFILE CROSS - SECTION	Range (mm)	Version	A (mm)	Hand	Base Raw	Anodised Elox	Painted	Trend/Gold Brass	Pieces per pack
043551	CHIC - T1 ARM T&T KIT	C001-C002-C003-C004-C005-C006	L 470 ÷ 700	Micro	98	RX	X				10
043552	CHIC - T1 ARM T&T KIT	C001-C002-C003-C004-C005-C006	L 470 ÷ 700	Micro	98	LX	X				10
043561	CHIC - T2 ARM T&T KIT	C001-C002-C003-C004-C005-C006	L 600 ÷ 1500	Micro	148÷178	RX	X				10
043562	CHIC - T2 ARM T&T KIT	C001-C002-C003-C004-C005-C006	L 600 ÷ 1500	Micro	148÷178	LX	X				10
043591	CHIC - T1 ARM T&T KIT (WITHOUT MICRO-VENTILATION)	C001-C002-C003-C004-C005-C006	L 445 ÷ 700	-	98	RX	X				10
043592	CHIC - T1 ARM T&T KIT (WITHOUT MICRO-VENTILATION)	C001-C002-C003-C004-C005-C006	L 445 ÷ 700	-	98	LX	X				10

CHIC 3D 100 FASTENING MECHANISMS

Functions

Tilt-and-Turn fastening mechanisms for cremone, window handle and NP SUPRA window handle, available in the Standard and Logica versions.

Materials

Drive, drive rod, mechanism bolt tip and strikers in zamak with GS Silver Plus finish (up to 500 h of corrosion resistance).

Screws and grub screws in stainless steel.

Polyamide raiser.

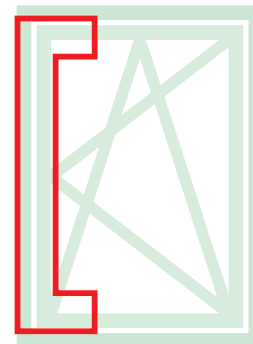

Online data sheet

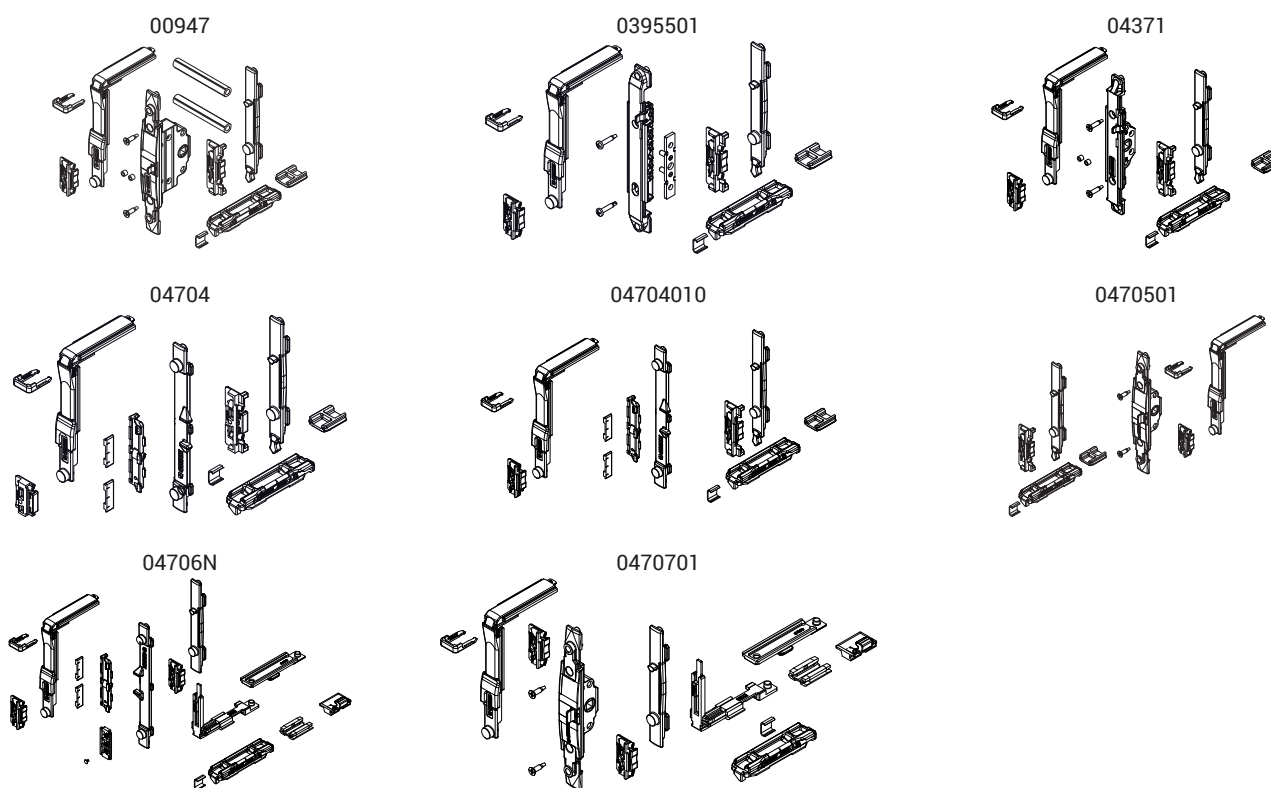

Item code	Description	PROFILE CROSS - SECTION	Mechanism	Version	Base Raw	Anodised Elox	Painted	Trend/Gold Brass	Pieces per pack
00947	T/T M 180 MOVEMENT FASTENING MECHANISM	C001-C002-C003-C005-C006-C013-C014-C015-C017	Window handle	-	X				10
0395501	T/T FASTENING MECHANISM	C001-C002-C004-C005-C006-C013-C014-C015-C016-C017	NP SUPRA	-	X				10
04371	FASTENING MECHANISM T/T MOVEMENT M 180	C001-C002-C004-C005-C006-C013-C014-C015-C016-C017	Window handle	-	X				10
04704	T/T FASTENING MECHANISM	C001-C002-C004-C005-C006-C013-C014-C015-C016-C017	Cremone	-	X				10
04704010	T/T FASTENING MECHANISM	C003	Cremone	-	X				10
0470501	T/T M 180 FASTENING MECHANISM	C001-C002-C004-C005-C006-C013-C014-C015-C016-C017	Window handle - SUPRA 7	-	X				10
04706N	T/T LOGICA FASTENING MECHANISM	C001-C002-C004-C005-C006-C013-C014-C015-C016-C017	Cremone	Logica	X				10
0470701	T/T M 180 LOGICA FASTENING MECHANISM	C001-C002-C004-C005-C006-C013-C014-C015-C016-C017	Window handle	Logica	X				10

CHIC 3D 100 ADDITIONAL FASTENING MECHANISMS AND HARDWARE

Functions

The additional fasteners make it possible to add further fastening elements that either increase the dimensions of the casement or that can be used when locking points are needed on the cross beams or hinge-side upright.

Technical Features

On the basis of the dimensions of the casement, additional fasteners (for $H > 1200$ mm and $W > 1000$ mm) and the additional arm (which is mandatory for $W > 1000$ mm) are to be used in combination with this mechanism.

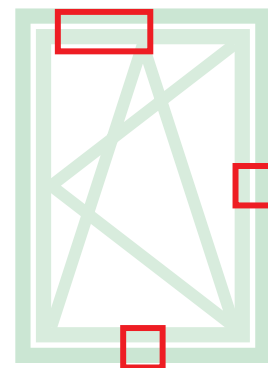

Online data sheet



02030K

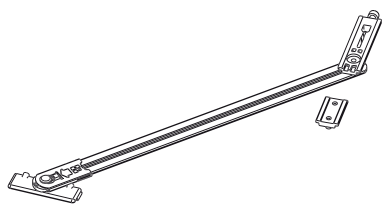

03535

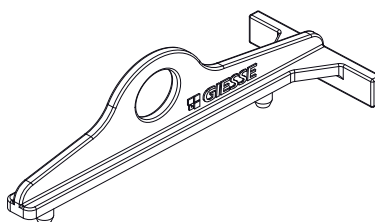

04024K

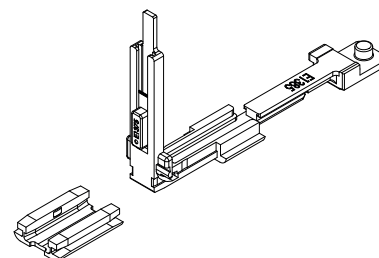

04301K

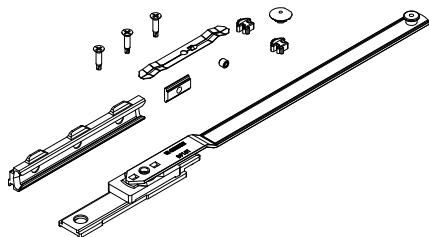

04357

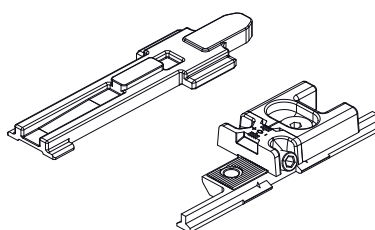

04770K

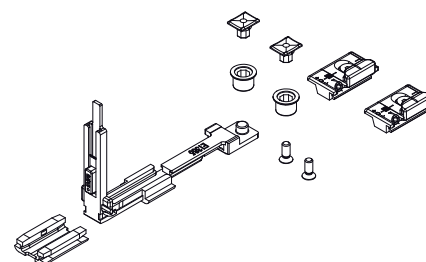

04777K

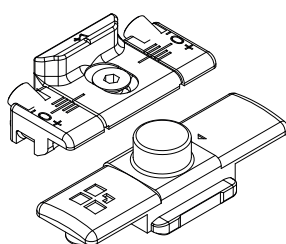

Mandatory to use the FRIZ arm

FRIZ arm positioning

Opening angle with FRIZ arm

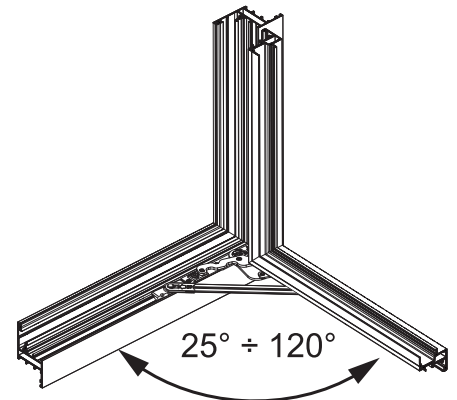
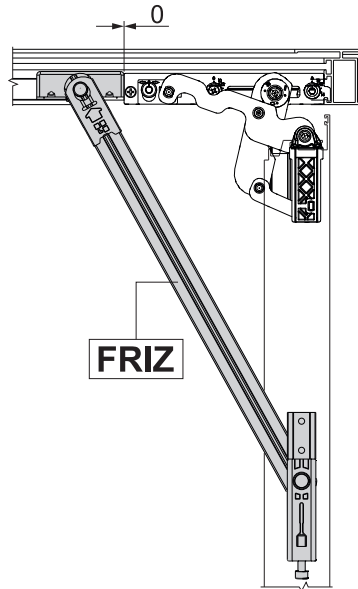
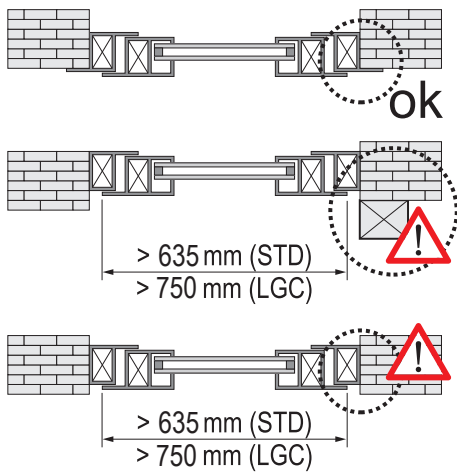

Item code	Description	PROFILE CROSS - SECTION	Range (mm)	Version	Base Raw	Anodised Elox	Painted	Trend/Gold Brass	Pieces per pack
02030K	FRIZ STAY LIMITATION ARM	C001-C002-005-C011-C013-C014-C015-C016-C017	See picture	-	X				10
03535	CHIC - TEMPLATE FOR TILT-AND-TURN	C001-C002-C003-C005-C006	-	-	X				10
04024K	CORNER DRIVE FOR FUTURA BURGLAR-PROOF FUNCTION	C001-C002-C003-C013-C014-C015-C016-C017	-	-	X				10
04301K	T/T FUTURA ADDITIONAL ARM	C001-C002-C003-C005-C006-C011-C013-C014-C015-C016-C017	W > 1000	-	X				5
04357	CHIC - ARM ADDITIONAL FASTENING MECHANISM	C001-C002-C003-C005-C006	-	-	X				10
04770K	FUTURA ADDITIONAL FASTENING MECHANISM	C001-C002-C003-C005-C006-C013-C014-C015-C016-C017	H > 1200 L > 1000	-	X				10
04777K	FUTURA ADDITIONAL FASTENING MECHANISM	C001-C002-C003-C005-C006-C011-C013-C014-C015-C016-C017	H > 1200 L > 1000	Logica	X				50

SECONDARY SASH HINGE SET FOR CHIC 3D 100

Functions

Set of hinges (top and bottom) for side-hung or secondary sash with tilt-and-turn CHIC 3D 100.

Technical Features

Sash opening to 180°.

Maximum load capacity 100 kg.

Assembly is simple, fast and easy using the special pre-assembled cams.

When there is an additional fastening mechanism, you need to use the CHIC fastening element.

Both hinges are adjustable (3D).

If opening is obstructed, you need to use the FRIZ limitation arm.

Materials

Corner support made of zamak

Connecting brackets and hinge plates made of zinc plated steel

Pins made of 304 grade stainless steel and aluminium bronze

Cams made of zinc plated steel

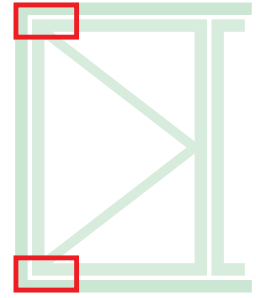

Online data sheet



043542

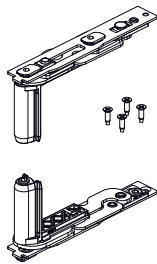

043541

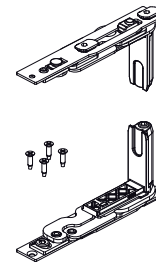

Mandatory to use the FRIZ arm

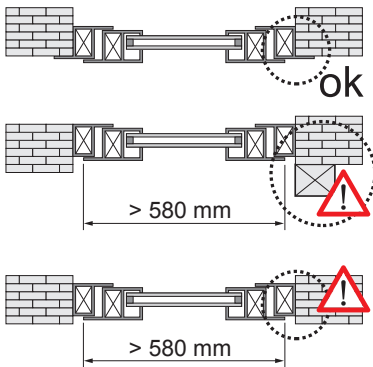

FRIZ arm positioning

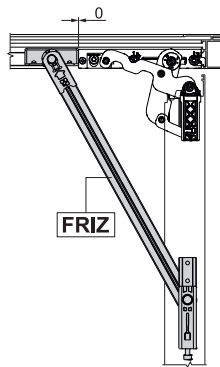

Opening angle with FRIZ arm

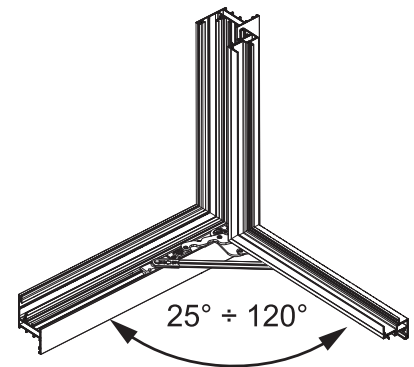

Item code	Description	PROFILE CROSS - SECTION	Hand	Base Raw	Anodised Elox	Painted	Trend/Gold Brass	Pieces per pack
043541	CHIC - SASH HINGE SET	C001-C002-C003-C005-C006	RX	X				10
043542	CHIC - SASH HINGE SET	C001-C002-C003-C005-C006	LX	X				10

CONFIGURATION EXAMPLES

CHIC 3D 100

Micro configuration with Cremone

MAIN SASH				
Sash width	445 ÷ 469*	470 ÷ 700	600 ÷ 1000	1001 ÷ 1500
Hinges + Arm	043591 - 043592	043551 - 043552	043561 - 043562	043561 - 043562
Mechanism	04704 - 04704010	04704 - 04704010	04704 - 04704010	04704 - 04704010
Additional arm	-	-	-	04301K
Cremone	01039 - 01094	01039 - 01094	01039 - 01094	01039 - 01094
SECONDARY SASH				
Hinges	043541 - 043542	043541 - 043542	043541 - 043542	043541 - 043542
Adjustable bolt	02168K	02168K	02168K	02168K
Single striker	01348	01348	01348	01348

* No Micro-ventilation

Micro configuration with window handle

MAIN SASH				
Sash width	445 ÷ 469*	470 ÷ 700	600 ÷ 1000	1001 ÷ 1500
Hinges + Arm	043591 - 043592	043551 - 043552	043561 - 043562	043561 - 043562
Mechanism	0470501	0470501	0470501	0470501
Additional arm	-	-	-	04301K
Window handle	02476 - 02415 - 00997	02476 - 02415 - 00997	02476 - 02415 - 00997	02476 - 02415 - 00997
SECONDARY SASH				
Hinges	043541 - 043542	043541 - 043542	043541 - 043542	043541 - 043542
Adjustable bolt	02168K	02168K	02168K	02168K
Single striker	01348	01348	01348	01348

* No Micro-ventilation

Micro configuration with NP Supra

MAIN SASH				
Sash width	445 ÷ 469*	470 ÷ 700	600 ÷ 1000	1001 ÷ 1500
Hinges + Arm	043591 - 043592	043551 - 043552	043561 - 043562	043561 - 043562
Mechanism	03955	03955	03955	03955
Additional arm	-	-	-	04301K
NP Supra	03962 - 03963	03962 - 03963	03962 - 03963	03962 - 03963
SECONDARY SASH				
Hinges	043541 - 043542	043541 - 043542	043541 - 043542	043541 - 043542
Adjustable bolt	02168K	02168K	02168K	02168K
Single striker	01348	01348	01348	01348

* No Micro-ventilation

Logica micro configuration with Cremone

MAIN SASH				
Sash width	445 ÷ 469*	470 ÷ 700	600 ÷ 1000	1001 ÷ 1500
Hinges + Arm	043591 - 043592	043551 - 043552	043561 - 043562	043561 - 043562
Mechanism	04706N - 04706010N	04706N - 04706010N	04706N - 04706010N	04706N - 04706010N
Additional arm	-	-	-	04301K
Cremone	01194 - 01195	01194 - 01195	01194 - 01195	01194 - 01195
SECONDARY SASH				
Hinges	043541 - 043542	043541 - 043542	043541 - 043542	043541 - 043542
Adjustable bolt	02168K	02168K	02168K	02168K
Single striker	01348	01348	01348	01348

* No Micro-ventilation

Logica configuration with window handle

MAIN SASH				
Sash width	445 ÷ 469*	470 ÷ 700	600 ÷ 1000	1001 ÷ 1500
Hinges + Arm	043591 - 043592	043551 - 043552	043561 - 043562	043561 - 043562
Mechanism	0470701	0470701	0470701	0470701
Additional arm	-	-	-	04301K
Window handle	02486	02486	02486	02486
SECONDARY SASH				
Hinges	043541 - 043542	043541 - 043542	043541 - 043542	043541 - 043542
Adjustable bolt	02168K	02168K	02168K	02168K
Single striker	01348	01348	01348	01348

* No Micro-ventilation

FLUSH CHIC 3D 100

Functions

Complete system for the construction of concealed tilt-and-turn windows with load capacities of up to 100 kg and with 105° sash opening. Available in the standard, logic and micro-ventilation versions.



CHIC 100

Technical Features

Making a CHIC 3D 100 Tilt-and-Turn mechanism requires:

1. Set of hinges + arms
2. Limitation arm
3. Set of fastening mechanisms for Cremones, window handles and SUPRA 7 window handles
4. Cremona, window handle and SUPRA 7 window handle (available in different models to choose from in the specific catalog section)

Adjustments

The adjustments are micrometric and independent.

Standard microventilation

Micro-ventilation enables having simultaneously both the tilt-and-turn position and micro-ventilation (precision opening of the sash) on the casement, for better air exchange.

Logica

The logical operation consists in first tilt-and-turn opening (with the cremona at 90°) and secondly side-hung opening (with the cremona at 180°). Its use is particularly recommended in public buildings (schools, hospitals, etc.) in combination with a cremona with a key in order to have only tilt-and-turn window opening for safety reasons and to allow full opening only for staff with the key.

Production micro-ventilation with standard opening

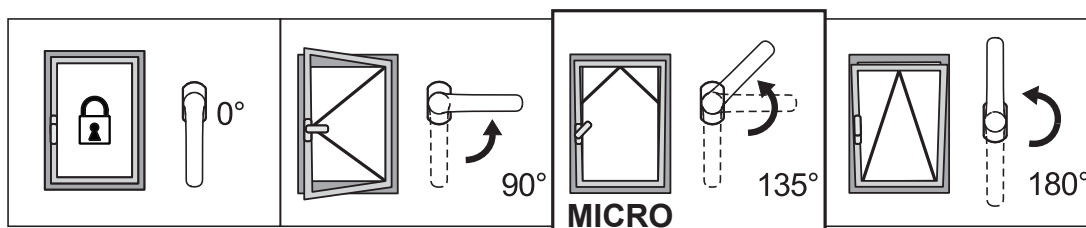

Production micro-ventilation with Logica opening

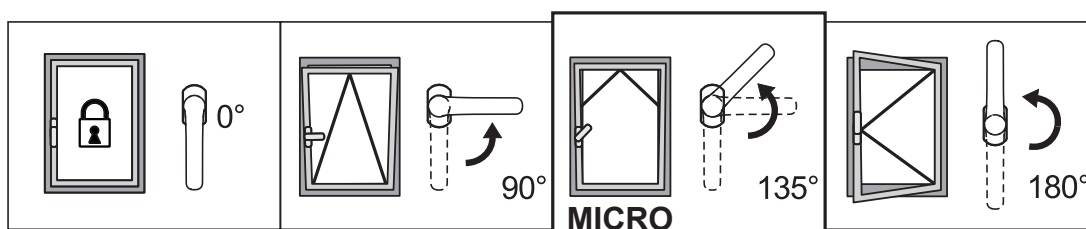

ADJUSTMENTS [mm]

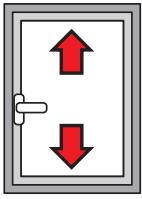

Height:
+2.5 / -1

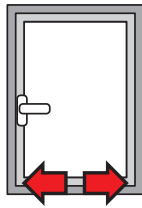

Side:
±1.5

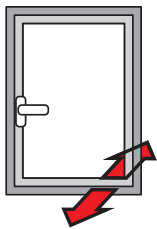

Bottom hinge compression:
+1.4 / -0.6

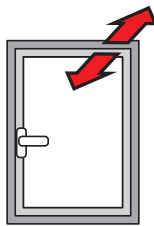

Top hinge compression:
±1.5

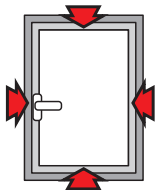

Striker compression:
±1.8

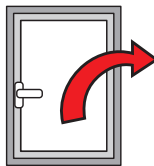

Sash fall:
+3.5 / -1.5

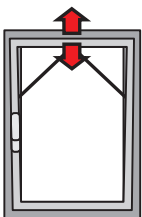

Micro-ventilation:
+3.6 / -1.8

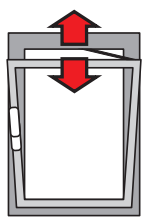

T2 arm opening:
148 ÷ 178

Table of maximum glass thickness [mm]

2500	33	27	23	20	18	16	15	14	13	12	11
2400	33	27	23	20	18	16	15	14	13	12	11
2300	34	28	24	21	19	17	16	14	13	12	11
2200	36	30	25	22	20	18	16	15	14	13	12
2100	37	31	27	23	21	19	17	16	14	13	12
2000	39	33	28	25	22	20	18	16	15	14	13
1900	41	34	30	26	23	21	19	17	16	15	14
1800	44	36	31	27	24	22	20	18	17	16	15
1700	46	38	33	29	26	23	21	19	18	16	15
1600	49	41	35	31	27	25	22	20	19	17	15
1500	50	44	37	33	29	26	24	22	20	17	15
1400	50	47	40	35	31	28	25	23	20	17	15
1300	50	50	43	38	34	30	27	24	20	17	15
1200	50	50	47	41	36	33	28	24	20	17	15
1100	50	50	50	45	40	34	28	24	20	17	
1000	50	50	50	49	42	34	28	24	20		
900	50	50	50	50	42	34	28	24			
800	50	50	50	50	42	34	28				
700	50	50	50	50	42	34					
600											
485	500	600	700	800	900	1000	1100	1200	1300	1400	1500

Table of maximum load capacity [kg]

2500	100	100	100	100	100	100	100	100	100	100	100
2400	100	100	100	100	100	100	100	100	100	100	100
2300	100	100	100	100	100	100	100	100	100	100	100
2200	100	100	100	100	100	100	100	100	100	100	100
2100	100	100	100	100	100	100	100	100	100	100	100
2000	100	100	100	100	100	100	100	100	100	100	100
1900	100	100	100	100	100	100	100	100	100	100	100
1800	100	100	100	100	100	100	100	100	100	100	100
1700	100	100	100	100	100	100	100	100	100	100	98
1600	100	100	100	100	100	100	100	100	100	99	92
1500	100	100	100	100	100	100	100	100	100	93	87
1400	100	100	100	100	100	100	100	100	93	87	81
1300	100	100	100	100	100	100	100	94	87	80	75
1200	100	100	100	100	100	100	95	87	80	74	69
1100	100	100	100	100	100	95	87	79	73	68	
1000	100	100	100	100	96	87	79	72	67		
900	100	100	100	98	87	78	71	65			
800	100	100	99	87	77	69	63				
700	100	100	87	76	67	61					
600											
485	500	600	700	800	900	1000	1100	1200	1300	1400	1500

FLUSH CHIC 3D 100 standard

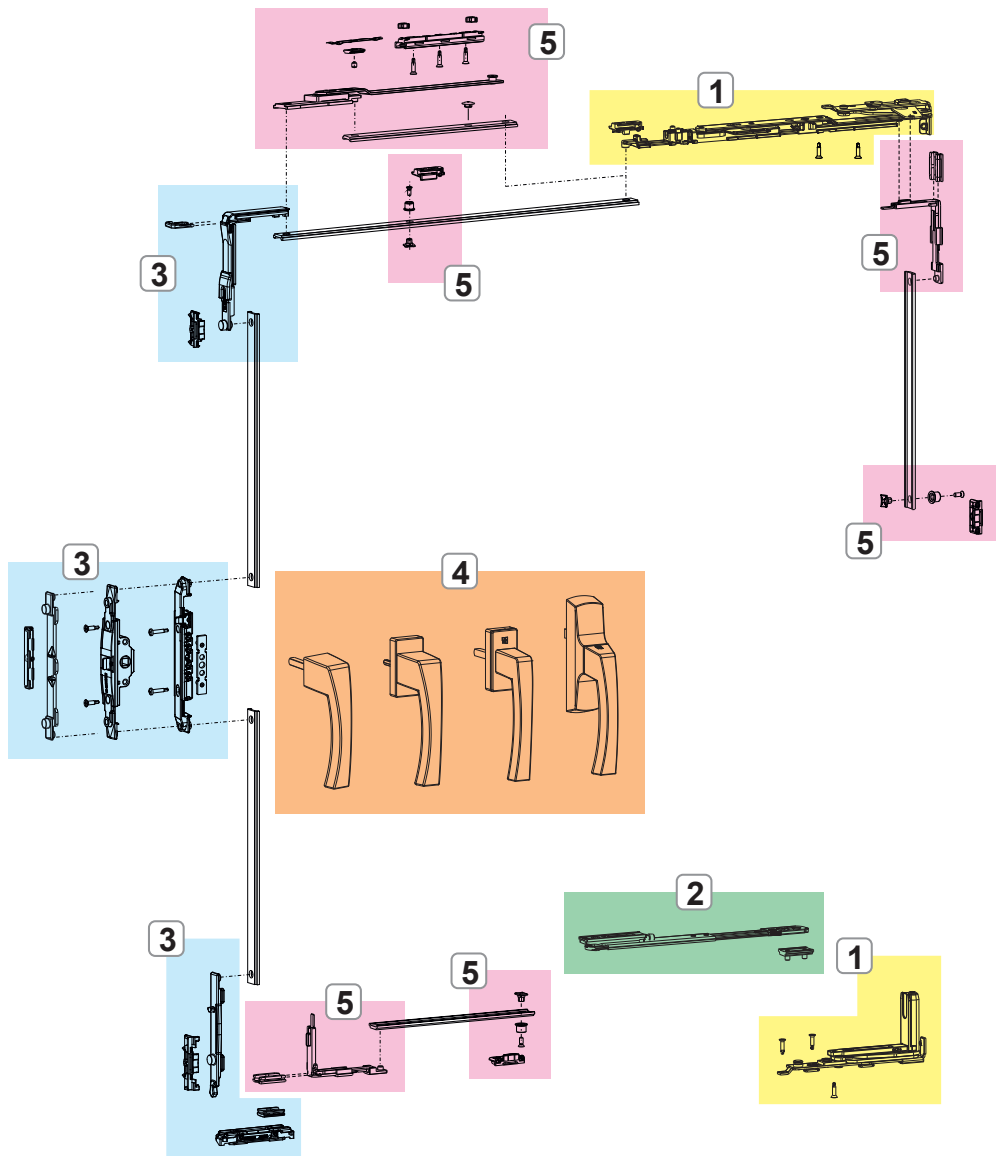

- 1. FLUSH CHIC 3D 100 HINGES AND ARMS
- 2. LIMITATION ARM
- 3. FLUSH CHIC 3D 100 FASTENING MECHANISM
- 4. CREMONE, WINDOW HANDLES AND SUPRA 7 WINDOW HANDLES
- 5. FLUSH CHIC 3D 100 ADDITIONAL FASTENING MECHANISMS AND COMPONENTS

CHIC 100

FLUSH CHIC 3D 100 logic

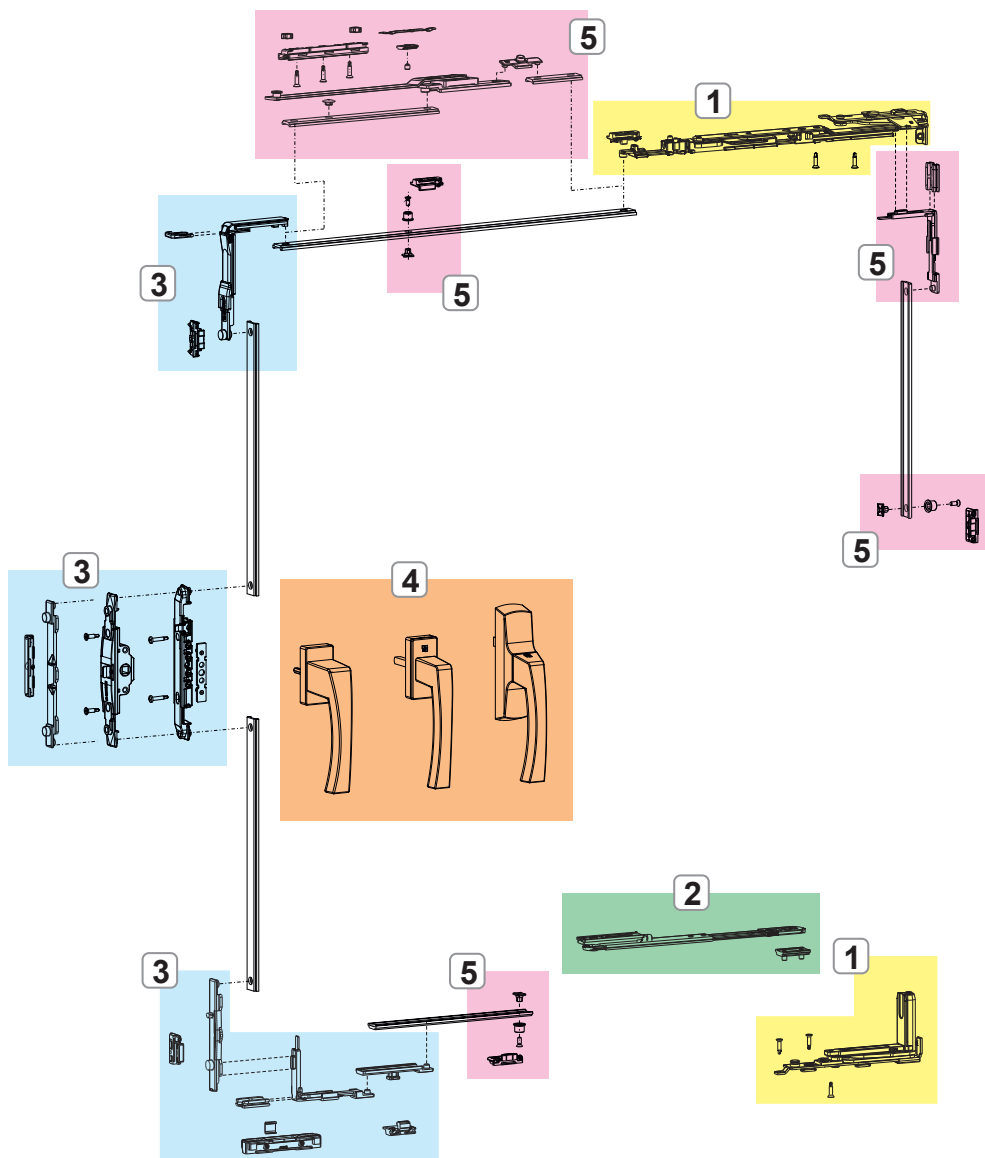

- 1. FLUSH CHIC 3D 100 HINGES AND ARMS
- 2. LIMITATION ARM
- 3. FLUSH CHIC 3D 100 FASTENING MECHANISM
- 4. CREMONESI, MARTELLINE E MANOVRE NP SUPRA
- 5. FLUSH CHIC 3D 100 ADDITIONAL FASTENING MECHANISMS AND COMPONENTS

FLUSH CHIC 3D 100 HINGES AND ARMS

Functions

Set of hinges (top and bottom), completely pre-assembled and ready to be installed on the profile.

Technical Features

They enable tilt-and-turn opening combined with the mechanisms.

Micro-ventilation and logica versions.

The arm is equipped with micro-ventilation as standard (adjustable).

Moving the fastening pawl takes the arm from conventional to logica.

The T2 arm is adjustable: the opening "A" goes from 178 mm (base) to 148 mm.

It is mandatory to use the CHIC limitation arm (code 05293).

Materials

Corner support made of zamak

Connecting brackets and hinge plates made of zinc plated steel

Pins made of 304 grade stainless steel and aluminium bronze

Cams made of zinc plated steel

Connecting bracket and arm rod made of 304 grade stainless steel

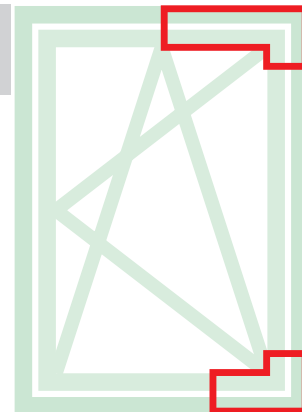

Online data sheet



052912

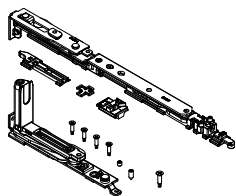

052911

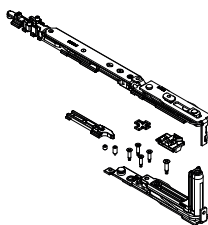

052922

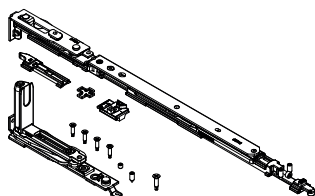

052921

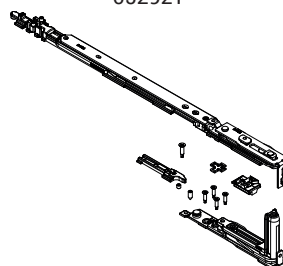

$\alpha^\circ \text{ MAX} = 105^\circ$

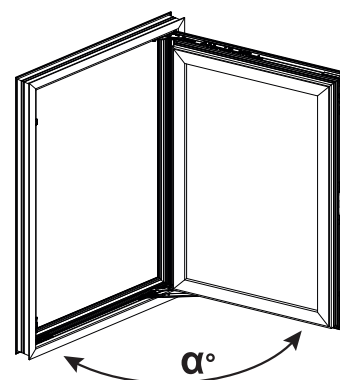

Sash opening



Item code	Description	PROFILE CROSS - SECTION	Range (mm)	Version	A (mm)	Hand	Base Pawl	Anodised Elox	Painted	Trend/Gold Brass	Pieces per pack
0529111	CHIC 100 FLUSH - AR ARM T1 KIT	C013-C014-C015-C016-017	W 485 ÷ 700	Micro	98	RX	X				10
0529121	CHIC 100 FLUSH - AR ARM T1 KIT	C013-C014-C015-C016-017	W 485 ÷ 700	Micro	98	LX	X				10
0529211	CHIC 100 FLUSH - AR ARM T2 KIT	C013-C014-C015-C016-017	L 600 ÷ 1500	Micro	148÷178	RX	X				10
0529221	CHIC 100 FLUSH - AR ARM T2 KIT	C013-C014-C015-C016-017	L 600 ÷ 1500	Micro	148÷178	LX	X				10

CHIC LIMITATION ARM

Functions

Accessory utilised to limit opening of the sash when movement of the sash is restricted by obstacles such as uprights or walls.

In the case of FLUSH CHIC it is essential to avoid damage to the hinge since the maximum opening allowed is 105°.

Technical Features

Sliding plate friction adjustable by means of suitable screw.

Applicable on tilt-and-turn window sashes with a minimum width of 485 mm.

Equipped with a spring-loaded manual quick release.

Stop plate fitted with two grub screws to prevent slippage.

Materials

Rod and stop plate made of pre-oxidised extruded aluminium.

Black polyamide frictioning element.

Pins, grub screws, spring and release in stainless steel.

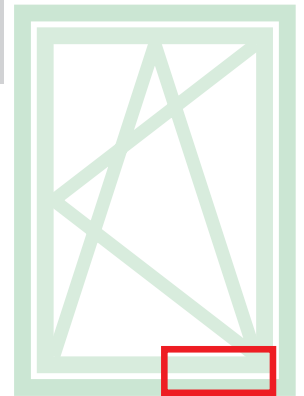

Online data sheet



05293

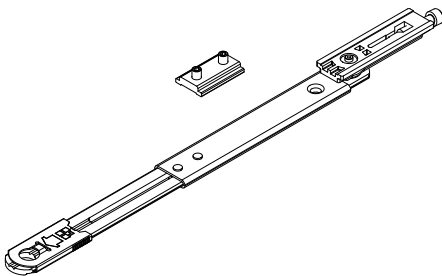

d (mm)	α°
102	105°
127	90°
>127	<90°
α° MAX 105	

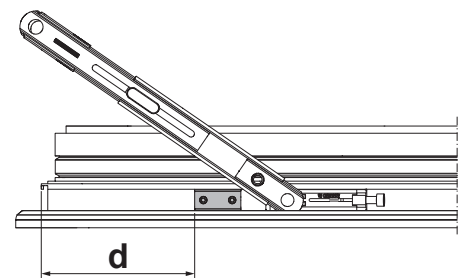
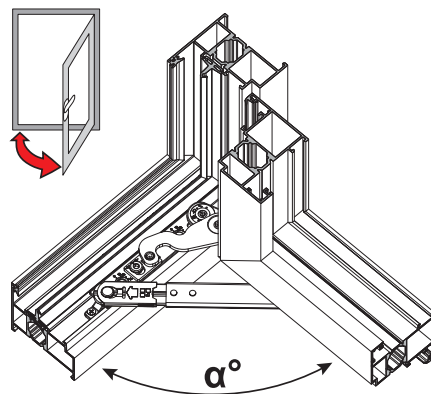

Item code	Description	Interface type	Base Raw	Anodised Elox	Painted	Trend/Gold Brass	Pieces per pack
05293	CHIC - LIMITATION ARM	C013-C014-C015-C016-C017	X				10

FLUSH CHIC 3D 100 FASTENING MECHANISM

Functions

Tilt-and-turn window fastening mechanisms for Cremona, window handle and SUPRA 7 window handle, available in Base and Logica versions.

Materials

Drive, drive rod, mechanism bolt tip and strikers in zamak with GS Silver Plus finish (up to 500 h of corrosion resistance).

Screws and grub screws in stainless steel.

Polyamide raiser.

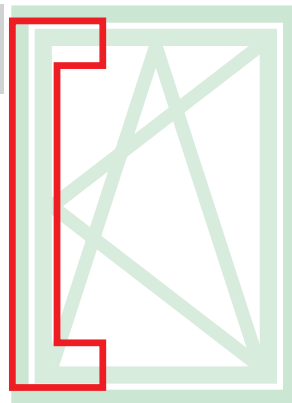

Online data sheet



00947

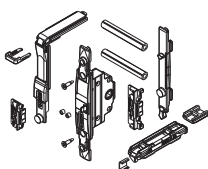

0395501

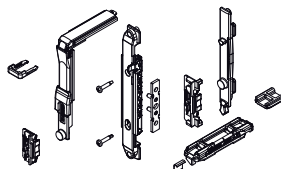

04371

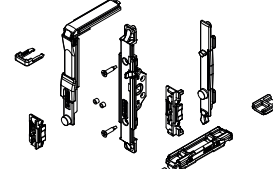

04704

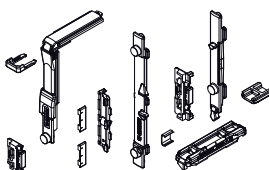

04704010

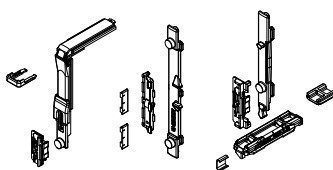

0470501

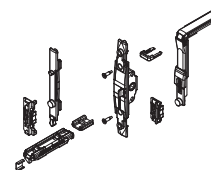

04706N

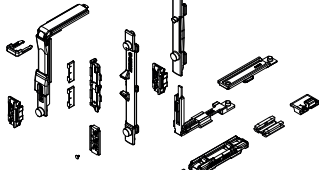

0470701

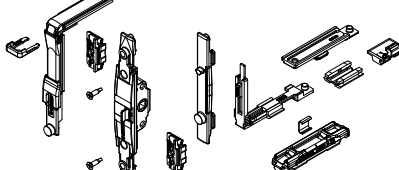

Item code	Descriptions	PROFILE CROSS - SECTION	Mechanism	Version	Base Raw	Anodised Elox	Painted	Trend/Gold Brass	Pieces per pack
00947	T/T M 180 MOVEMENT FASTENING MECHANISM	C001-C002-C003-C005-C006-C013-C014-C015-C017	Window handle	-	X				10
0395501	T/T FASTENING MECHANISM	C001-C002-C003-C005-C006-C013-C014-C015-C017	NP SUPRA	-	X				10
04371	FASTENING MECHANISM T/T MOVEMENT M 180	C001-C002-C004-C005-C006-C013-C014-C015-C016-C017	Window handle - SUPRA 7	-	X				10
04704	T/T FASTENING MECHANISM	C001-C002-C003-C005-C006-C013-C014-C015-C016-C017	Cremona	-	X				10
04704010	T/T FASTENING MECHANISM	C001-C003	Cremona	-	X				10
0470501	T/T M 180 FASTENING MECHANISM	C001-C002-C004-C005-C006-C013-C014-C015-C016-C017	Window handle - SUPRA 7	-	X				10
04706N	T/T LOGICA FASTENING MECHANISM	C001-C002-C003-C005-C006-C013-C014-C015-C016-C017	Cremona	Logica	X				10
0470701	T/T M 180 LOGICA FASTENING MECHANISM	C001-C002-C004-C005-C006-C013-C014-C015-C016-C017	Window handle	Logica	X				10

FLUSH CHIC 3D 100 ADDITIONAL FASTENING MECHANISMS AND COMPONENTS

Functions

The additional fasteners make it possible to add further fastening elements that either increase the dimensions of the casement or that can be used when locking points are needed on the cross beams or hinge-side upright.

Technical Features

On the basis of the dimensions of the casement, additional fasteners (for H>1200 mm and W>1000 mm) and the additional arm (which is mandatory for W>1000 mm) are to be used in combination with this mechanism.

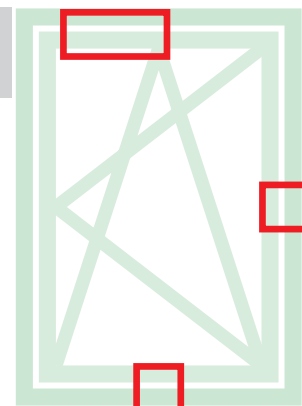

Online data sheet



05289

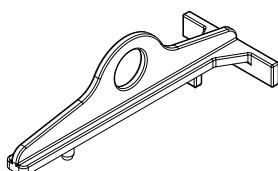

04024K

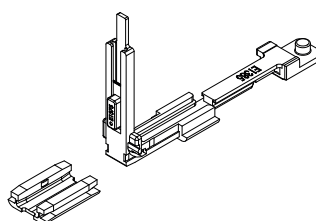

04777K

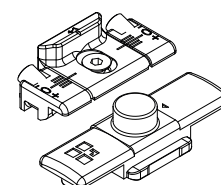

04770K

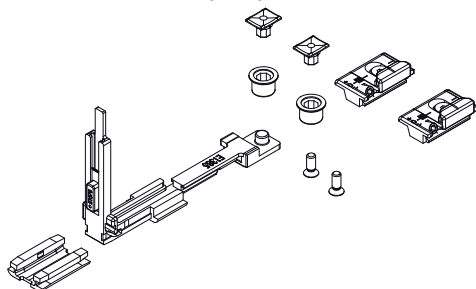

04301K

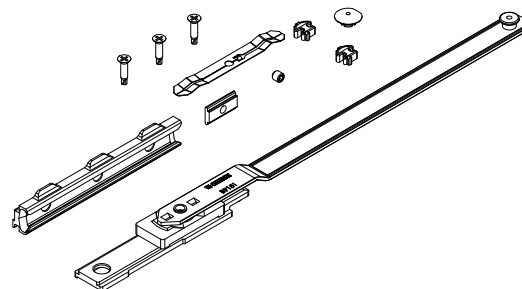

Item code	Description	Interface type	Range (mm)	Version	Base Raw	Anodised Elox	Painted	Trend/Gold Brass	Pieces per pack
05289	CHIC FLUSH - TEMPLATE FOR AR	C013-C014-C015-C016-C017	-	-	X				10
04024K	CORNER DRIVE FOR FUTURA BURGLAR-PROOF FUNCTION	C001-C002-C003-C013-C014-C015-C016-C017	-	-	X				10
04301K	T/T FUTURA ADDITIONAL ARM	C001-C002-C003-C005-C006-C011-C013-C014-C015-C016-C017	W > 1000	-	X				5
04770K	FUTURA ADDITIONAL FASTENING MECHANISM	C001-C002-C003-C005-C006-C013-C014-C015-C016-C017	H > 1200 L > 1000	-	X				10
04777K	FUTURA ADDITIONAL FASTENING MECHANISM	C001-C002-C003-C005-C006-C011-C013-C014-C015-C016-C017	H > 1200 L > 1000	Logica	X				50

FLUSH CHIC 3D 100 SECONDARY SASH HINGE KIT

Functions

CHIC 3D 100 FLUSH hinge set (top and bottom) for side-hung sash or secondary sash combined with turn-and-tilt sash.

Technical Features

Sash opening to 105°.

Maximum load capacity 100 kg.

Assembly is simple, fast and easy using the special pre-assembled cams.

When there is an additional fastening mechanism, you need to use the CHIC fastening element.

Both hinges are adjustable (3D).

It is mandatory to use the CHIC limitation arm (code 05293).

Materials

Corner support made of zamak

Connecting brackets and hinge plates made of zinc plated steel

Pins made of 304 grade stainless steel and aluminium bronze

Cams made of zinc plated steel

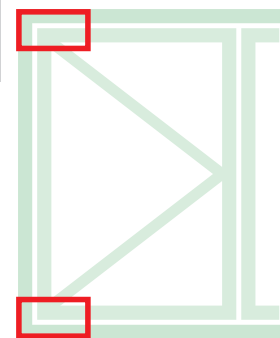

Online data sheet



052902

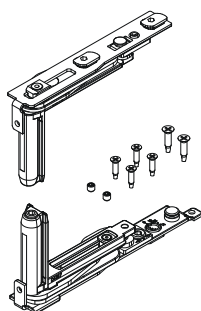

052901

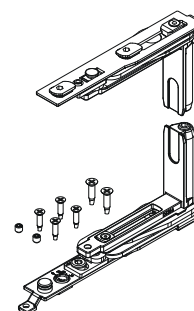

CHIC limitation arm(05293)

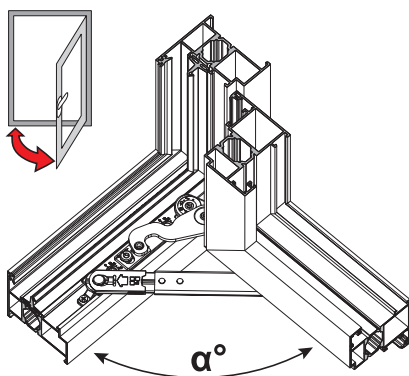

d (mm)	α°
102	105°
127	90°
>127	<90°
α° MAX 105	

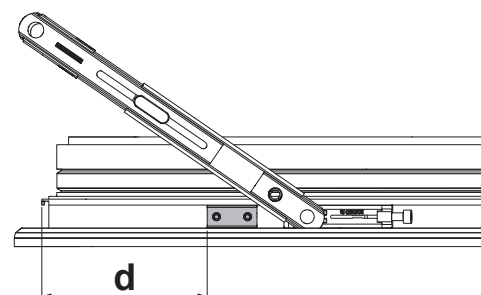

Item code	Description	PROFILE CROSS - SECTION	Hand	Base Raw	Anodised Elox	Painted	Trend/Gold Brass	Pieces per pack
052901	CHIC 100 FLUSH - SASH HINGE KIT	C013-C014-C015-C016-017	RX					10
052902	CHIC 100 FLUSH - SASH HINGE KIT	C013-C014-C015-C016-017	LX					10

CONFIGURATION EXAMPLES

FLUSH CHIC 3D 100

Micro configuration with Cremone

MAIN SASH			
Sash width	485 ÷ 700	600 ÷ 1000	1001 ÷ 1500
Hinges + Arm	052911 - 052912	052921 - 052922	052921 - 052922
Limitation arm	05293	05293	05293
Mechanism	04704 - 04704010	04704 - 04704010	04704 - 04704010
Additional arm	-	-	04301K
Cremone	01039 - 01094	01039 - 01094	01039 - 01094
SECONDARY SASH			
Hinges	052901 - 052902	052901 - 052902	052901 - 052902
Adjustable bolt	02168K	02168K	02168K
Single striker	01348K	01348K	01348K

Logica micro configuration with Cremone

MAIN SASH			
Sash width	595 ÷ 700	600 ÷ 1000	1001 ÷ 1500
Hinges + Arm	052911 - 052912	052921 - 052922	052921 - 052922
Limitation arm	05293	05293	05293
Mechanism	04706N - 04706010N	04706N - 04706010N	04706N - 04706010N
Additional arm	-	-	04301K
Cremone	01194 - 01195	01194 - 01195	01194 - 01195
SECONDARY SASH			
Hinges	052901 - 052902	052901 - 052902	052901 - 052902
Adjustable bolt	02168K	02168K	02168K
Single striker	01348K	01348K	01348K

Micro configuration with window handle

MAIN SASH			
Sash width	485 ÷ 700	600 ÷ 1000	1001 ÷ 1500
Hinges + Arm	052911 - 052912	052921 - 052922	052921 - 052922
Limitation arm	05293	05293	05293
Mechanism	0470501	0470501	0470501
Additional arm	-	-	04301K
Window handle	02476 - 02415 - 00997	02476 - 02415 - 00997	02476 - 02415 - 00997
SECONDARY SASH			
Hinges	052901 - 052902	052901 - 052902	052901 - 052902
Adjustable bolt	02168K	02168K	02168K
Single striker	01348K	01348K	01348K

Logica configuration with window handle

MAIN SASH			
Sash width	595 ÷ 700	600 ÷ 1000	1001 ÷ 1500
Hinges + Arm	052911 - 052912	052921 - 052922	052921 - 052922
Limitation arm	05293	05293	05293
Mechanism	0470701	0470701	0470701
Additional arm	-	-	04301K
Window handle	02486	02486	02486
SECONDARY SASH			
Hinges	052901 - 052902	052901 - 052902	052901 - 052902
Adjustable bolt	02168K	02168K	02168K
Single striker	01348K	01348K	01348K

Micro with Supra 7 configuration

MAIN SASH			
Sash width	485 ÷ 700	600 ÷ 1000	1001 ÷ 1500
Hinges + Arm	052911 - 052912	052921 - 052922	052921 - 052922
Limitation arm	05293	05293	05293
Mechanism	0470501	0470501	0470501
Additional arm	-	-	04301K
SUPRA 7	04153 - 04154 - 04155 - 04156	04153 - 04154 - 04155 - 04156	04153 - 04154 - 04155 - 04156
SECONDARY SASH			
Hinges	052901 - 052902	052901 - 052902	052901 - 052902
Adjustable bolt	02168K	02168K	02168K
Single striker	01348K	01348K	01348K

CHIC 3D 130

Functions

Complete system for the construction of concealed tilt-and-turn windows with load capacities of up to 130 kg and with 180° sash opening. Available in the standard, logica and micro-ventilation versions.

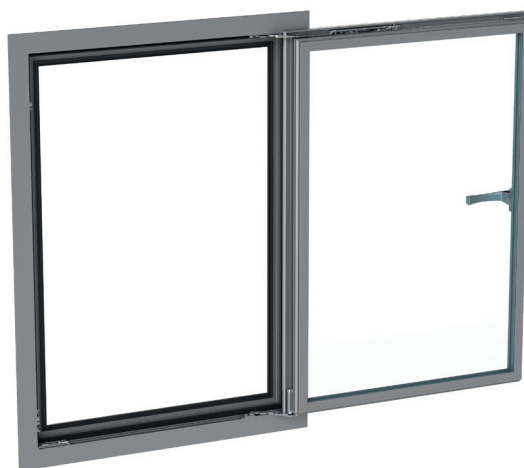

CHIC 130

Technical Features

Making a CHIC 3D 130 Tilt-and-Turn mechanism requires:

1. Set of hinges + arms
2. Set of mechanisms for cremones, window handles and NP SUPRA window handles
3. Cremone, window handle or NP SUPRA window handle (available in different models to choose from in the specific catalogue section)

Adjustments

The adjustments are micrometric and independent.

Standard microventilation

Micro-ventilation enables having simultaneously both the tilt-and-turn position and micro-ventilation (precision opening of the sash) on the casement, for better air exchange.

Logica

The logica operation consists in first tilt-and-turn opening (with the cremone at 90°) and secondly side-hung opening (with the cremone at 180°). Its use is particularly recommended in public buildings (schools, hospitals, etc.) in combination with a cremone with a key in order to have only tilt-and-turn window opening for safety reasons and to allow full opening only for staff with the key.

Production micro-ventilation with standard opening

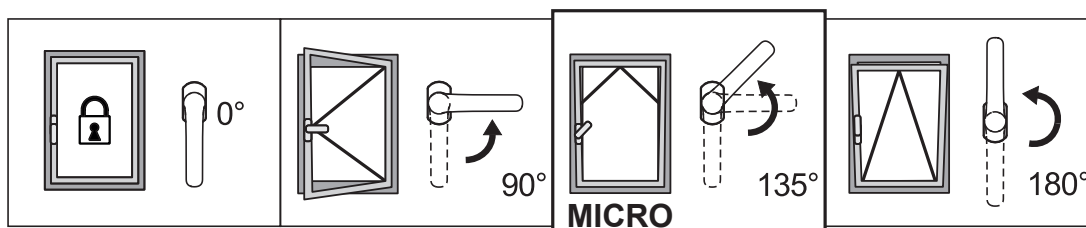

Production micro-ventilation with Logica opening

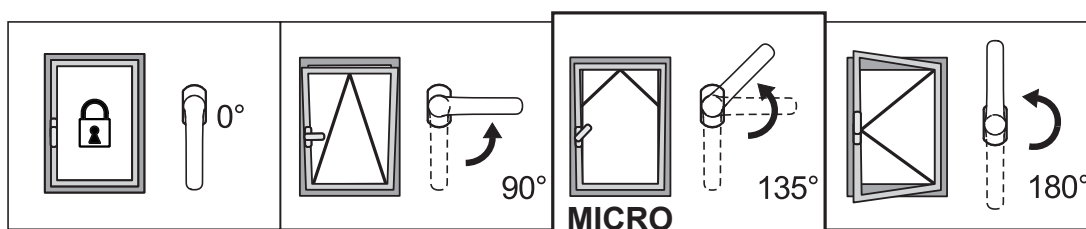

ADJUSTMENTS [mm]

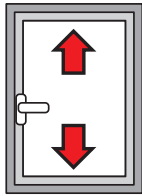

Height:
+2.5 / -1

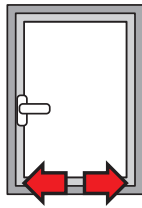

Side:
±1.5

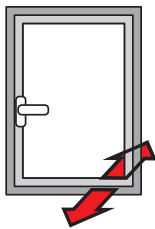

Bottom hinge compression:
+1.4 / -0.6

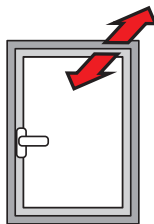

Top hinge compression:
±1.5

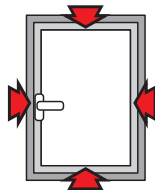

Striker compression:
±1.8

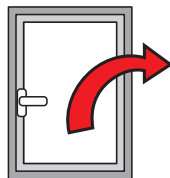

Sash fall:
+3.5 / -1.5

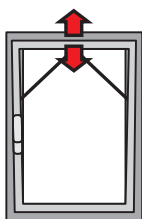

Micro-ventilation:
+3.6 / -1.8

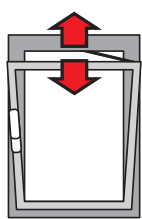

T2 arm opening:
148 ÷ 178

Table of maximum glass thickness [mm]

2800	35	29	25	22	19	17	16	14	13	12	12	
2700	37	31	26	23	20	18	17	15	14	13	12	
2600	39	32	28	24	21	19	18	16	15	14	13	12
2500	43	35	30	27	24	21	19	18	16	15	14	13
2400	43	35	30	27	24	21	19	18	16	15	14	13
2300	44	37	32	28	25	22	20	18	17	16	15	14
2200	46	39	33	29	26	23	21	19	18	17	15	14
2100	49	40	35	30	27	24	22	20	19	17	16	15
2000	51	43	36	32	28	26	23	21	20	18	17	16
1900	54	45	38	34	30	27	24	22	21	19	18	17
1800	57	47	40	35	31	28	26	24	22	20	19	18
1700	60	50	43	38	33	30	27	25	23	21	20	18
1600	60	53	46	40	35	32	29	27	25	23	21	18
1500	60	57	49	43	38	34	31	28	26	24	21	18
1400	60	60	52	46	40	36	33	30	28	24	21	18
1300	60	60	56	49	44	39	36	33	28	24	21	18
1200	60	60	60	53	47	43	39	33	28	24	21	
1100	60	60	60	58	52	46	39	33	28	24		
1000	60	60	60	60	57	47	39	33	28			
900	60	60	60	60	58	47	39	33				
800	60	60	60	60	58	47	39					
700	60	60	60	60	58	47						
600	500	600	700	800	900	1000	1100	1200	1300	1400	1500	1600
470												

Table of maximum load capacity [kg]

2800	124	124	124	124	124	124	124	124	124	124	124		
2700	126	126	126	126	126	126	126	126	126	126	126		
2600	128	128	128	128	128	128	128	128	128	128	128	128	
2500	130	130	130	130	130	130	130	130	130	130	130	130	
2400	130	130	130	130	130	130	130	130	130	130	130	130	
2300	130	130	130	130	130	130	130	130	130	130	130	130	
2200	130	130	130	130	130	130	130	130	130	130	130	130	
2100	130	130	130	130	130	130	130	130	130	130	130	130	
2000	130	130	130	130	130	130	130	130	130	130	130	130	
1900	130	130	130	130	130	130	130	130	130	130	130	130	
1800	130	130	130	130	130	130	130	130	130	130	130	130	
1700	130	130	130	130	130	130	130	130	130	130	130	127	
1600	130	130	130	130	130	130	130	130	130	130	127	119	
1500	130	130	130	130	130	130	130	130	130	128	119	112	
1400	130	130	130	130	130	130	130	130	129	119	111	104	
1300	130	130	130	130	130	130	130	129	119	111	103	97	
1200	130	130	130	130	130	130	130	119	110	102	95		
1100	130	130	130	130	130	130	119	109	101	94			
1000	130	130	130	130	130	119	108	99	92				
900	130	130	130	130	119	107	98	90					
800	130	130	130	119	106	95	87						
700	130	130	119	104	93	84							
600	470	500	600	700	800	900	1000	1100	1200	1300	1400	1500	1600

CHIC 130

CHIC 3D 130 standard

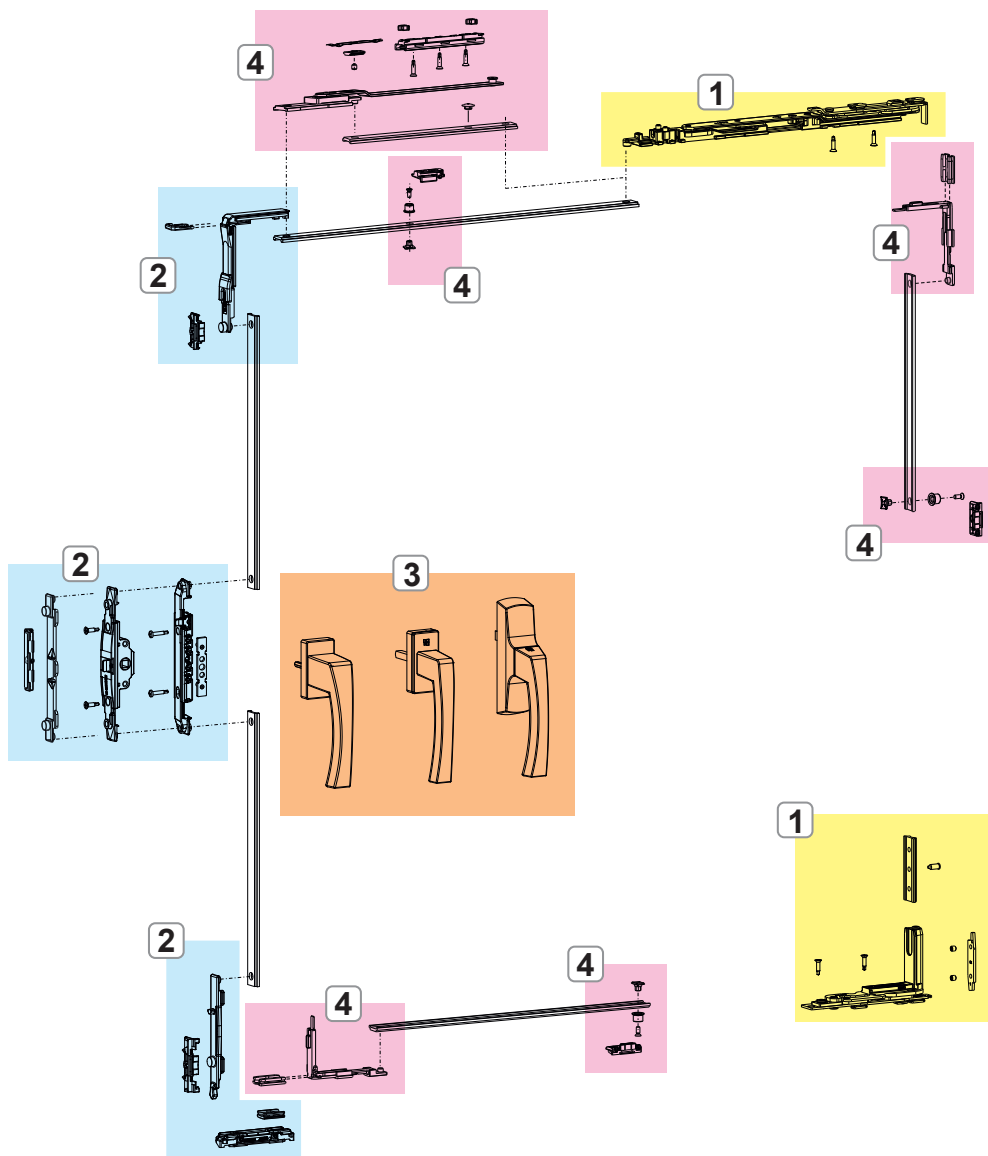

- 1. CHIC 3D 130 HINGES AND ARMS
- 2. CHIC 3D 130 FASTENING MECHANISMS
- 3. NP SUPRA CREMONES, WINDOW HANDLES AND MECHANISMS
- 4. CHIC 3D 130 ADDITIONAL FASTENING MECHANISMS AND HARDWARE

CHIC 130

CHIC 3D 130 logica

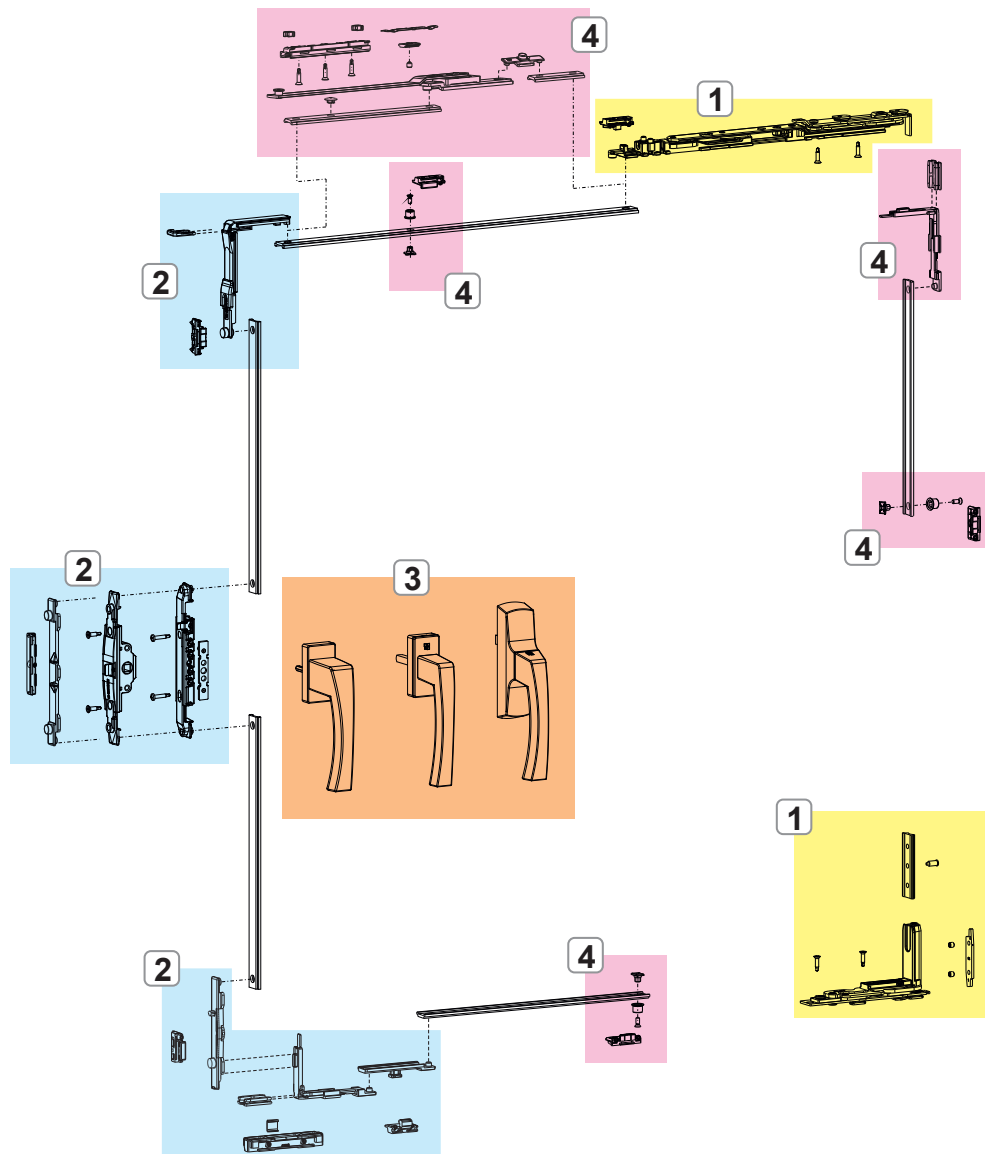

1. CHIC 3D 130 HINGES AND ARMS
2. CHIC 3D 130 FASTENING MECHANISMS
3. NP SUPRA CREMONES, WINDOW HANDLES AND MECHANISMS
4. CHIC 3D 130 ADDITIONAL FASTENING MECHANISMS AND HARDWARE

CHIC 3D 130 HINGES AND ARMS

Functions

Set of hinges (top and bottom), completely pre-assembled and ready to be installed on the profile.

Technical Features

They enable tilt-and-turn opening combined with the mechanisms.

Micro-ventilation and logica versions.

The arm is equipped with micro-ventilation as standard (adjustable).

Moving the fastening pawl takes the arm from conventional to logica.

The T2 arm is adjustable: the opening "A" goes from 178 mm (base) to 148 mm.

Materials

Corner support made of zamak

Connecting brackets and hinge plates made of zinc plated steel

Pins made of 304 grade stainless steel and aluminium bronze

Cams made of zinc plated steel

Connecting bracket and arm rod made of 304 grade stainless steel

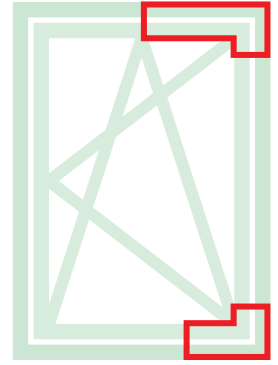

Online data sheet

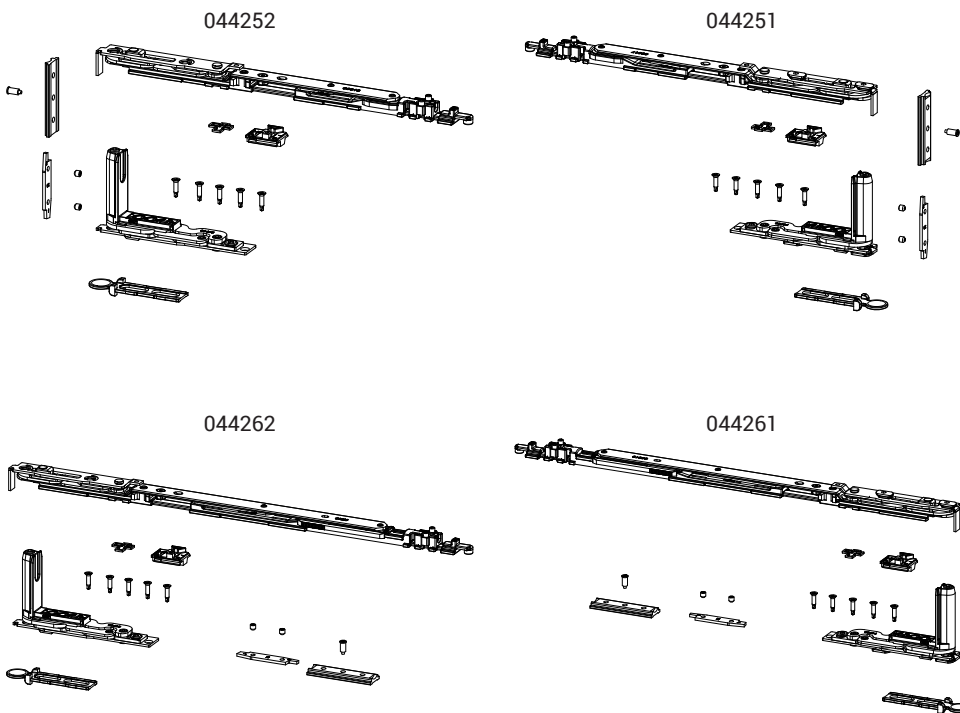

Sash opening

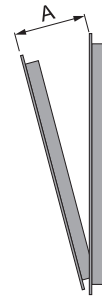

Item code	Description	PROFILE CROSS - SECTION	Range (mm)	Version	A (mm)	Hand	Base Raw	Anodised Elox	Painted	Trend/Gold Brass	Pieces per pack
044251	CHIC - T1 ARM T&T KIT	C001-C002-C003-C004-C005-C006	L 470 ÷ 700	Micro	98	RX	X				10
044252	CHIC - T1 ARM T&T KIT	C001-C002-C003-C004-C005-C006	L 470 ÷ 700	Micro	98	LX	X				10
044261	CHIC - T2 ARM T&T KIT	C001-C002-C003-C004-C005-C006	L 600 ÷ 1600	Micro	148÷178	RX	X				10
044262	CHIC - T2 ARM T&T KIT	C001-C002-C003-C004-C005-C006	L 600 ÷ 1600	Micro	148÷178	LX	X				10

CHIC 3D 130 FASTENING MECHANISMS

Functions

Tilt-and-Turn fastening mechanisms for cremone, window handle and NP SUPRA window handle, available in the Standard and Logica versions.

Materials

Drive, drive rod, mechanism bolt tip and strikers in zamak with GS Silver Plus finish (up to 500 h of corrosion resistance).

Screws and grub screws in stainless steel.

Polyamide raiser.

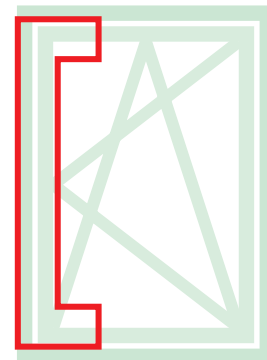

Online data sheet

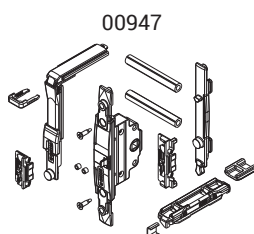

00947

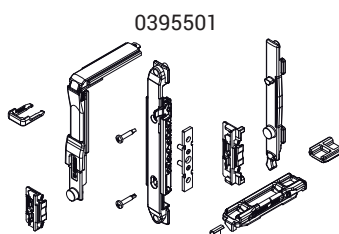

0395501

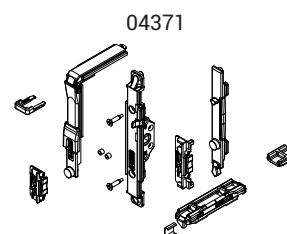

04371

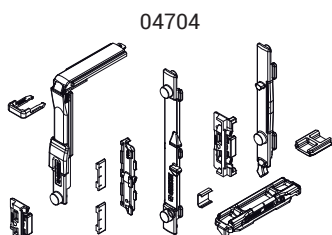

04704

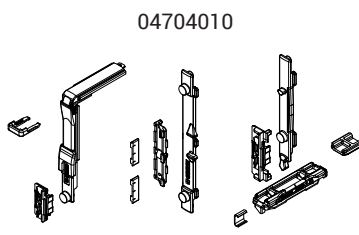

04704010

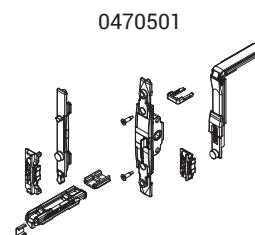

0470501

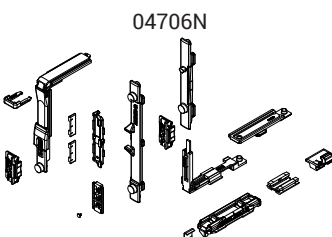

04706N

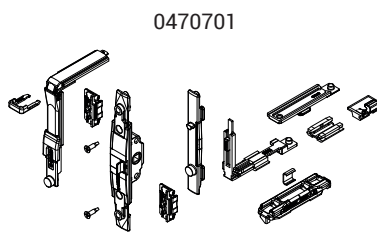

0470701

Item code	Description	PROFILE CROSS - SECTION	Mechanism	Version	Base Raw	Anodised Elox	Painted	Trend/Gold Brass	Pieces per pack
00947	T/T M 180 MOVEMENT FASTENING MECHANISM	C001-C002-C003-C005-C006-C013-C014-C015-C017	Window handle	-	X				10
0395501	T/T FASTENING MECHANISM	C001-C002-C003-C005-C006-C013-C014-C015-C017	NP SUPRA	-	X				10
04371	FASTENING MECHANISM T/T MOVEMENT M 180	C001-C002-C004-C005-C006-C013-C014-C015-C016-C017	Window handle - SUPRA 7	-	X				10
04704	T/T FASTENING MECHANISM	C001-C002-C003-C005-C006-C013-C014-C015-C016-C017	Cremone	-	X				10
04704010	T/T FASTENING MECHANISM	C001-C003	Cremone	-	X				10
0470501	T/T M 180 FASTENING MECHANISM	C001-C002-C004-C005-C006-C013-C014-C015-C016-C017	Window handle - SUPRA 7	-	X				10
04706N	T/T LOGICA FASTENING MECHANISM	C001-C002-C003-C005-C006-C013-C014-C015-C016-C017	Cremone	Logica	X				10
0470701	T/T M 180 LOGICA FASTENING MECHANISM	C001-C002-C004-C005-C006-C013-C014-C015-C016-C017	Window handle	Logica	X				10

CHIC 3D 130 ADDITIONAL FASTENING MECHANISMS AND HARDWARE

Functions

The additional fasteners make it possible to add further fastening elements that either increase the dimensions of the casement or that can be used when locking points are needed on the cross beams or hinge-side upright.

Technical Features

On the basis of the dimensions of the casement, additional fasteners (for $H > 1200$ mm and $W > 1000$ mm) and the additional arm (which is mandatory for $W > 1000$ mm) are to be used in combination with this mechanism.

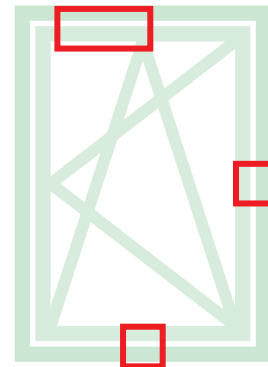

Online data sheet



02030K

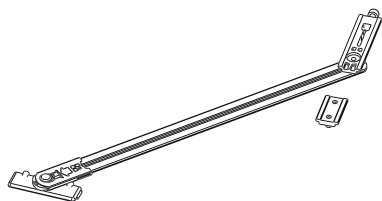

03535

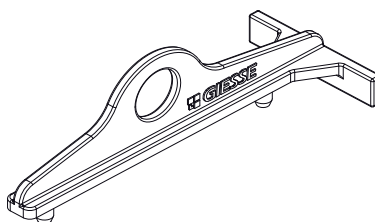

04024K

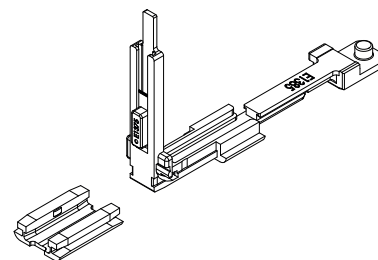

04301K

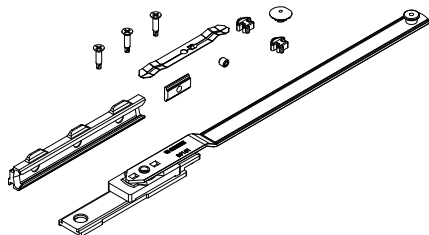

04357

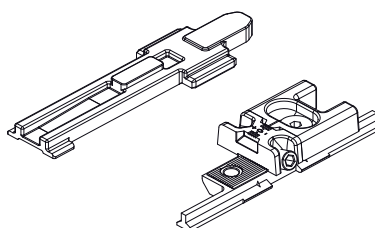

04770K

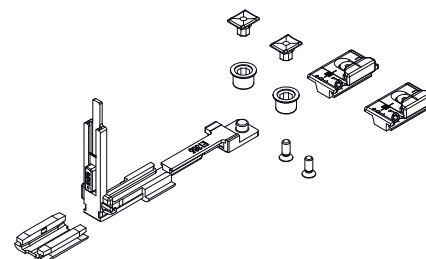

04777K

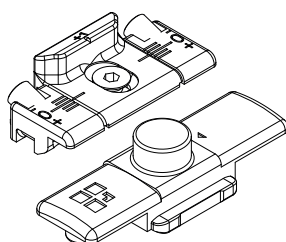

Mandatory to use the FRIZ arm

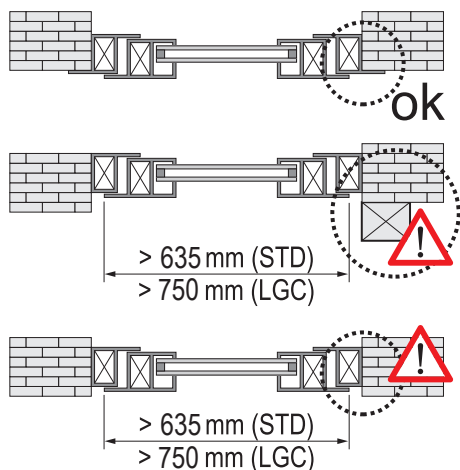

FRIZ arm positioning

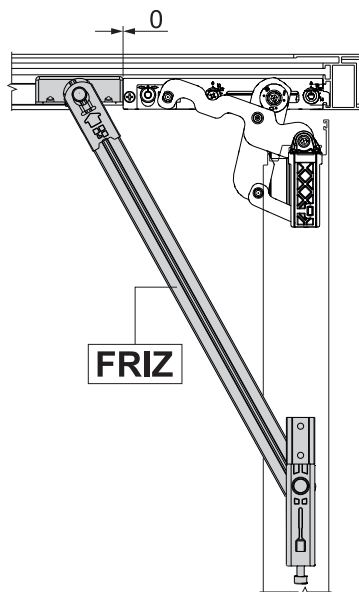

Opening angle with FRIZ arm

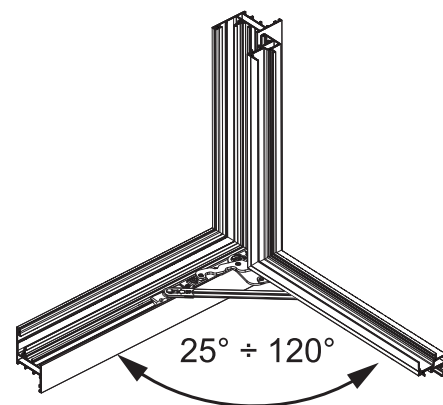

Item code	Description	PROFILE CROSS - SECTION	Range (mm)	Version	Base Raw	Anodised Elox	Painted	Trend/Gold Brass	Pieces per pack
02030K	FRIZ STAY LIMITATION ARM	C001-C002-C004-C011-C012-C013-C014-C015-C016-C017	See picture	-	X				10
03535	CHIC - TEMPLATE FOR TILT-AND-TURN	C001-C002-C003-C004-C005-C006	-	-	X				10
04024K	CORNER DRIVE FOR FUTURA BURGLAR-PROOF FUNCTION	C001-C002-C003-C004-C005-C006-C013-C014-C015-C016-C017	-	-	X				10
04301K	T/T FUTURA ADDITIONAL ARM	C001-C002-C003-C004-C005-C006	W > 1000	-	X				5
04357	CHIC - ARM ADDITIONAL FASTENING MECHANISM	C001-C002-C003-C004-C005-C006	-	-	X				10
04770K	FUTURA ADDITIONAL FASTENING MECHANISM	C001-C002-C003-C004-C005-C006-C013-C014-C015-C016-C017	H > 1200 L > 1000	-	X				10
04777K	FUTURA ADDITIONAL FASTENING MECHANISM	C001-C002-C003-C004-C005-C006-C013-C014-C015-C016-C017	H > 1200 L > 1000	Logica	X				50

SECONDARY SASH HINGE SET FOR CHIC 3D 130

Functions

Set of hinges (top and bottom) for side-hung or secondary sash with tilt-and-turn CHIC 3D 130.

Technical Features

Sash opening to 180°.

Maximum load capacity 130 kg.

Assembly is simple, fast and easy using the special pre-assembled cams.

When there is an additional fastening mechanism, you need to use the CHIC fastening element.

Both hinges are adjustable (3D).

If opening is obstructed, you need to use the FRIZ limitation arm.

Materials

Corner support made of zamak

Connecting brackets and hinge plates made of zinc plated steel

Pins made of 304 grade stainless steel and aluminium bronze

Cams made of zinc plated steel

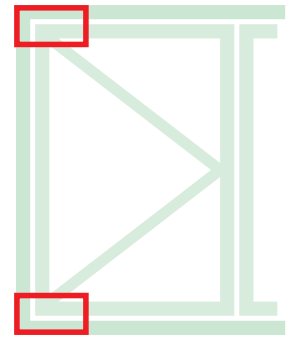

Online data sheet



044242

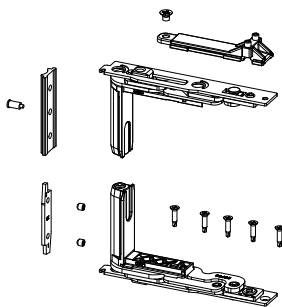

044241

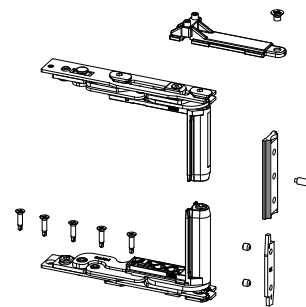

Mandatory to use the FRIZ arm

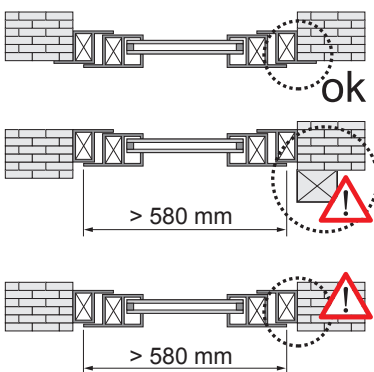

FRIZ arm positioning

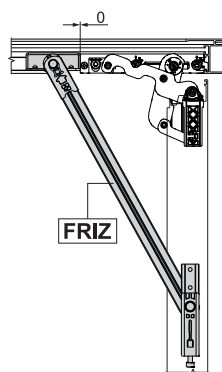

Opening angle with FRIZ arm

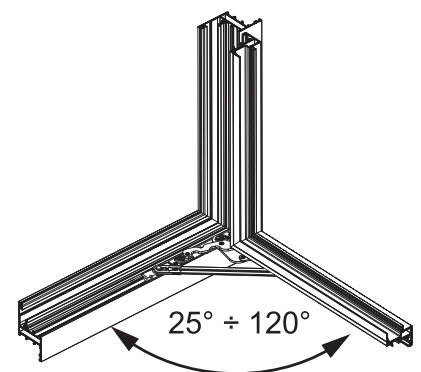

Item code	Description	PROFILE CROSS - SECTION	Hand	Base Raw	Anodised Elox	Painted	Trend/Gold Brass	Pieces per pack
044241	CHIC - SASH HINGE SET	C001-C002-C003-C004-C005-C006	RX	X				10
044242	CHIC - SASH HINGE SET	C001-C002-C003-C004-C005-C006	LX	X				10

CONFIGURATION EXAMPLES

CHIC 3D 130

Micro configuration with Cremone

MAIN SASH			
Sash width	470 ÷ 700	600 ÷ 1000	1001 ÷ 1600
Hinges + Arm	044251 - 044252	044261 - 044262	044261 - 044262
Mechanism	04704 - 04704010	04704 - 04704010	04704 - 04704010
Additional arm	-	-	04301K
Cremone	01039 - 01094 - 01084	01039 - 01094 - 01084	01039 - 01094 - 01084
SECONDARY SASH			
Hinges	044241 - 044242	044241 - 044242	044241 - 044242
Adjustable bolt	02168K	02168K	02168K
Single striker	01348	01348	01348

Micro configuration with window handle

MAIN SASH			
Sash width	470 ÷ 700	600 ÷ 1000	1001 ÷ 1600
Hinges + Arm	044251 - 044252	044261 - 044262	044261 - 044262
Mechanism	0470501	0470501	0470501
Additional arm	-	-	04301K
Window handle	02476 - 02415 - 00997	02476 - 02415 - 00997	02476 - 02415 - 00997
SECONDARY SASH			
Hinges	044241 - 044242	044241 - 044242	044241 - 044242
Adjustable bolt	02168K	02168K	02168K
Single striker	01348	01348	01348

Micro configuration with NP Supra

MAIN SASH			
Sash width	470 ÷ 700	600 ÷ 1000	1001 ÷ 1600
Hinges + Arm	044251 - 044252	044261 - 044262	044261 - 044262
Mechanism	03955	03955	03955
Additional arm	-	-	04301K
NP Supra	03962 - 03963	03962 - 03963	03962 - 03963
SECONDARY SASH			
Hinges	044241 - 044242	044241 - 044242	044241 - 044242
Adjustable bolt	02168K	02168K	02168K
Single striker	01348	01348	01348

Logica micro configuration with Cremone

MAIN SASH			
Sash width	470 ÷ 700	600 ÷ 1000	1001 ÷ 1600
Hinges + Arm	044251 - 044252	044261 - 044262	044261 - 044262
Mechanism	04706N - 04706010N	04706N - 04706010N	04706N - 04706010N
Additional arm	-	-	04301K
Cremone	01194 - 01087	01194 - 01087	01194 - 01087
SECONDARY SASH			
Hinges	044241 - 044242	044241 - 044242	044241 - 044242
Adjustable bolt	02168K	02168K	02168K
Single striker	01348	01348	01348

Logica configuration with window handle

MAIN SASH			
Sash width	470 ÷ 700	600 ÷ 1000	1001 ÷ 1600
Hinges + Arm	044251 - 044252	044261 - 044262	044261 - 044262
Mechanism	0470701	0470701	0470701
Additional arm	-	-	04301K
Window handle	02486	02486	02486
SECONDARY SASH			
Hinges	044241 - 044242	044241 - 044242	044241 - 044242
Adjustable bolt	02168K	02168K	02168K
Single striker	01348	01348	01348

CHIC 3D 150

Functions

Complete system for the construction of tilt-and-turn windows with load capacities of up to 150 kg. Available in the standard, logica and microventilation versions.

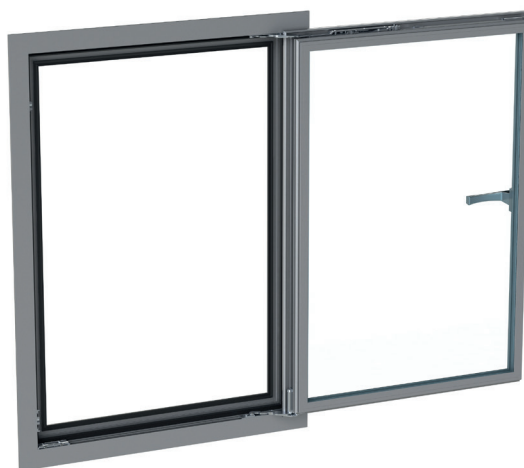

CHIC 150

Technical Features

Making a CHIC 3D 150 Tilt-and-Turn mechanism requires:

1. Set of hinges + arms
2. Set of mechanisms for cremones, window handles and NP SUPRA window handles
3. Cremone, window handle or NP SUPRA window handle (available in different models to choose from in the specific catalogue section)

Adjustments

The adjustments are micrometric and independent.

Standard microventilation

Micro-ventilation enables having simultaneously both the tilt-and-turn position and micro-ventilation (precision opening of the sash) on the casement, for better air exchange.

Logica

The logical operation consists in first tilt-and-turn opening (with the cremone at 90°) and secondly side-hung opening (with the cremone at 180°). Its use is particularly recommended in public buildings (schools, hospitals, etc.) in combination with a cremone with a key in order to have only tilt-and-turn window opening for safety reasons and to allow full opening only for staff with the key.

Production micro-ventilation with standard opening

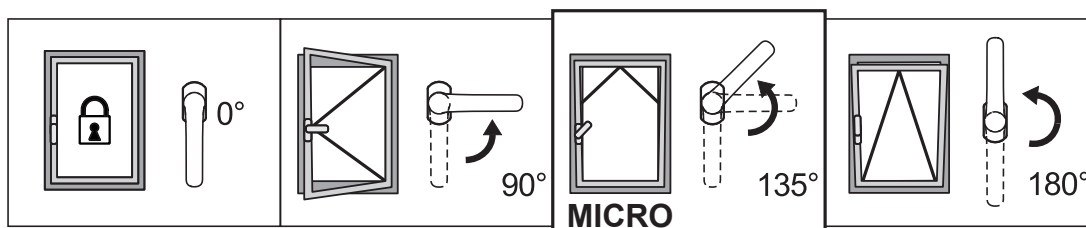

Production micro-ventilation with Logica opening

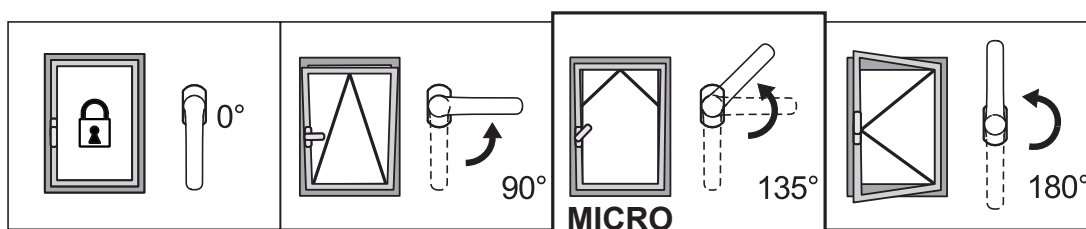

ADJUSTMENTS [mm]

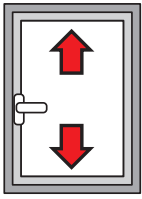

Height:
+2.5 / -1

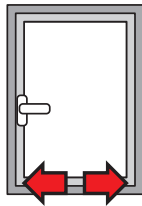

Side:
±1.5

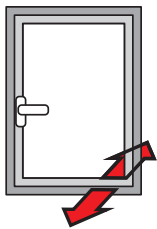

Bottom hinge compression:
+1.4 / -0.6

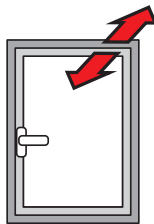

Top hinge compression:
±1.5

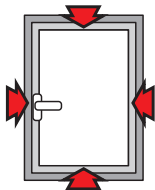

Striker compression:
±1.8

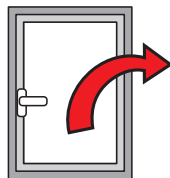

Sash fall:
+3.5 / -1.5

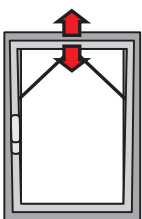

Micro-ventilation:
+3.6 / -1.8

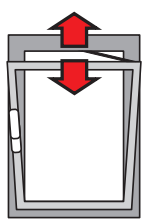

T2 arm opening:
148 ÷ 178

Table of maximum glass thickness [mm]

2800	40	33	29	25	22	20	18	17	15	14		
2700	42	35	30	26	23	21	19	18	16	15		
2600	45	37	32	28	25	22	20	19	17	16	15	
2500	49	41	35	31	27	25	22	20	19	18	16	15
2400	49	41	35	31	27	25	22	20	19	18	16	15
2300	51	43	37	32	28	26	23	21	20	18	17	16
2200	54	45	38	33	30	27	24	22	21	19	18	17
2100	56	47	40	35	31	28	25	23	22	20	19	18
2000	59	49	42	37	33	29	27	25	23	21	20	18
1900	60	52	44	39	34	31	28	26	24	22	21	19
1800	60	55	47	41	36	33	30	27	25	23	22	20
1700	60	58	49	43	38	35	31	29	27	25	23	20
1600	60	60	53	46	41	37	33	31	28	26	23	20
1500	60	60	56	49	44	39	36	33	30	26	23	20
1400	60	60	60	53	47	42	38	35	30	26	23	20
1300	60	60	60	57	50	45	41	35	30	26	23	20
1200	60	60	60	60	55	49	42	35	30	26	23	
1100	60	60	60	60	59	51	42	35	30	26		
1000	60	60	60	60	60	51	42	35	30			
900	60	60	60	60	60	51	42	35				
800	60	60	60	60	60	51	42					
700	60	60	60	60	60	51						
600	500	600	700	800	900	1000	1100	1200	1300	1400	1500	1600
470												

Table of maximum load capacity [kg]

2800	143	143	143	143	143	143	143	143	143	143			
2700	145	145	145	145	145	145	145	145	145	145			
2600	148	148	148	148	148	148	148	148	148	148	148		
2500	150	150	150	150	150	150	150	150	150	150	150	150	
2400	150	150	150	150	150	150	150	150	150	150	150	150	
2300	150	150	150	150	150	150	150	150	150	150	150	150	
2200	150	150	150	150	150	150	150	150	150	150	150	150	
2100	150	150	150	150	150	150	150	150	150	150	150	150	
2000	150	150	150	150	150	150	150	150	150	150	150	150	
1900	150	150	150	150	150	150	150	150	150	150	150	150	
1800	150	150	150	150	150	150	150	150	150	150	150	146	
1700	150	150	150	150	150	150	150	150	150	150	147	138	
1600	150	150	150	150	150	150	150	150	150	148	138	130	
1500	150	150	150	150	150	150	150	150	150	139	130	122	
1400	150	150	150	150	150	150	150	150	140	130	121	113	
1300	150	150	150	150	150	150	150	140	130	120	112	105	
1200	150	150	150	150	150	150	141	130	120	111	104		
1100	150	150	150	150	150	143	130	119	110	102			
1000	150	150	150	150	144	130	118	108	100				
900	150	150	150	146	130	117	106	97					
800	150	150	148	130	115	104	94						
700	150	150	130	113	101	91							
600	470	500	600	700	800	900	1000	1100	1200	1300	1400	1500	1600

CHIC 150

CHIC 3D 150 standard

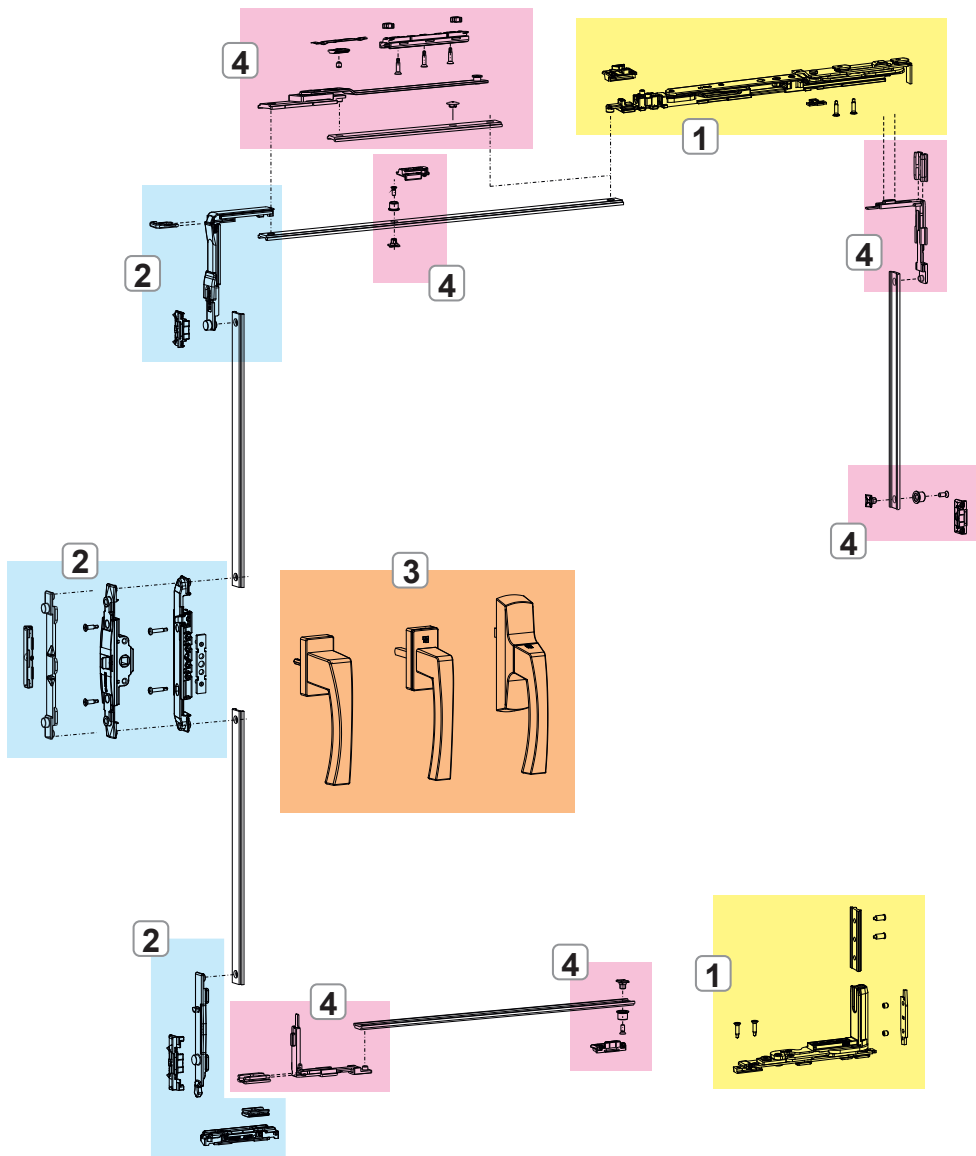

- 1. CHIC 3D 150 HINGES AND ARMS
- 2. CHIC 3D 150 FASTENING MECHANISMS
- 3. NP SUPRA CREMONES, WINDOW HANDLES AND MECHANISMS
- 4. CHIC 3D 150 ADDITIONAL FASTENING MECHANISMS AND HARDWARE

CHIC 150

CHIC 3D 150 logica

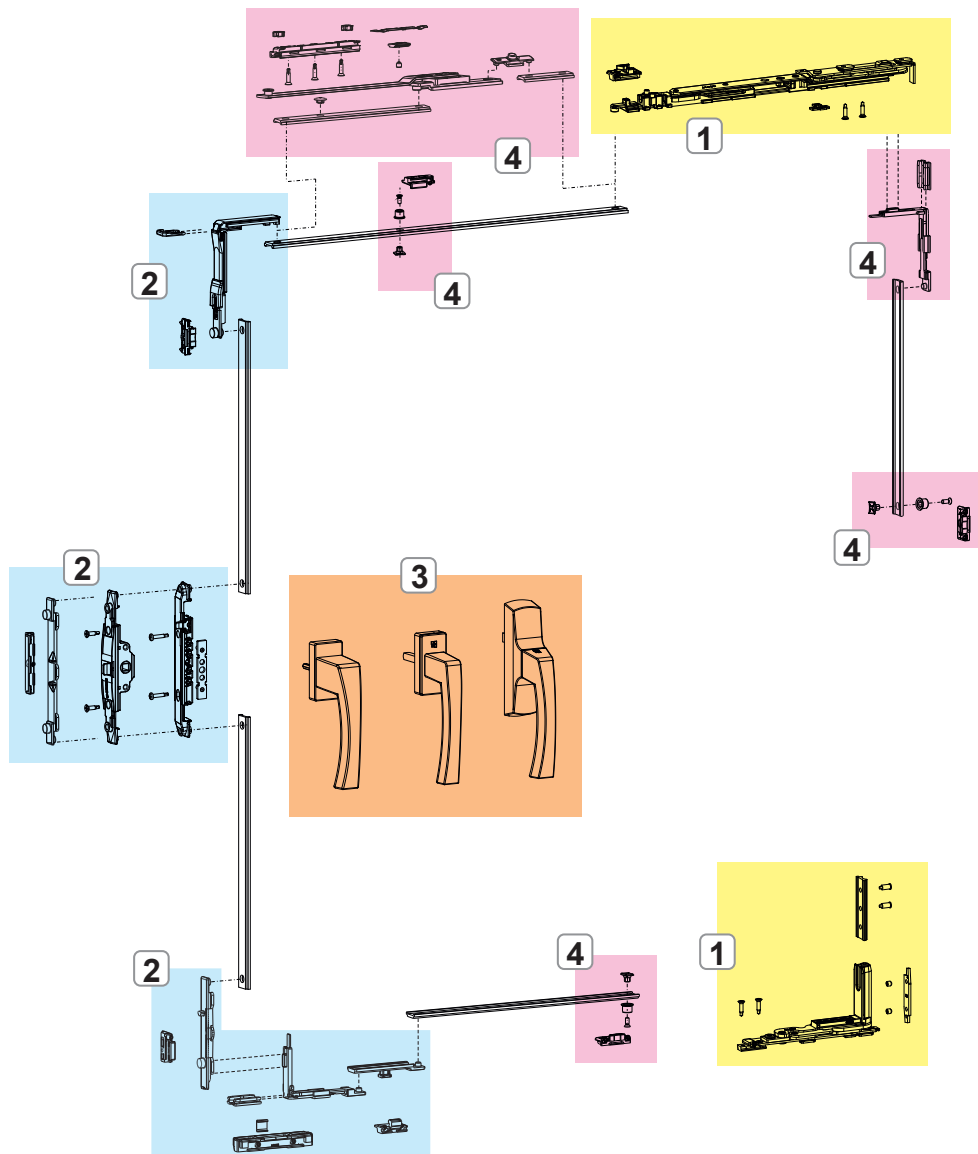

1. CHIC 3D 150 HINGES AND ARMS
2. CHIC 3D 150 FASTENING MECHANISMS
3. NP SUPRA CREMONES, WINDOW HANDLES AND MECHANISMS
4. CHIC 3D 150 ADDITIONAL FASTENING MECHANISMS AND HARDWARE

CHIC 3D 150 HINGES AND ARMS

Functions

Set of hinges (top and bottom), completely pre-assembled and ready to be installed on the profile.

Technical Features

They enable tilt-and-turn opening combined with the mechanisms.

Available in right- and left-hand versions.

Micro-ventilation and logica versions.

The arm is equipped with micro-ventilation as standard (adjustable).

Moving the fastening pawl takes the arm from conventional to logica.

The T2 arm is adjustable: the opening "A" goes from 178 mm (base) to 148 mm.

Materials

Corner support made of zamak

Connecting brackets and hinge plates made of zinc plated steel

Pins made of 304 grade stainless steel and aluminium bronze

Cams made of zinc plated steel

Connecting bracket and arm rod made of 304 grade stainless steel

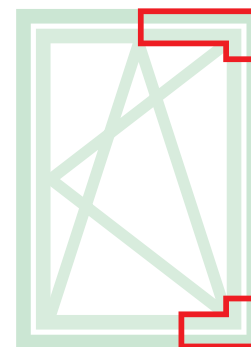

[Online data sheet](#)



0436521

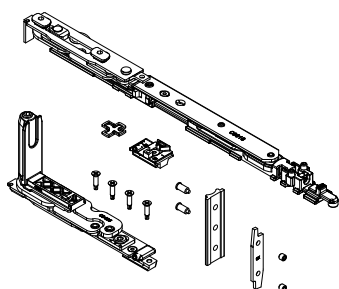

0436511

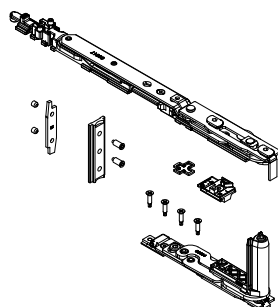

0436621

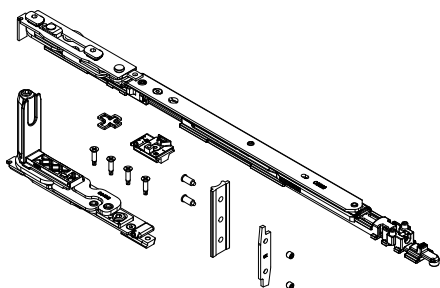

0436611

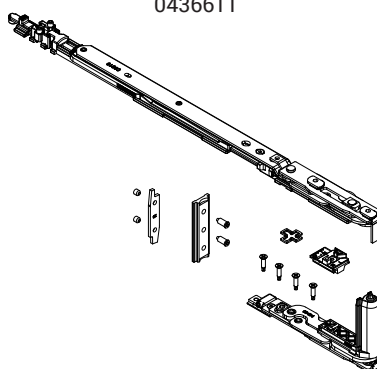

Sash opening



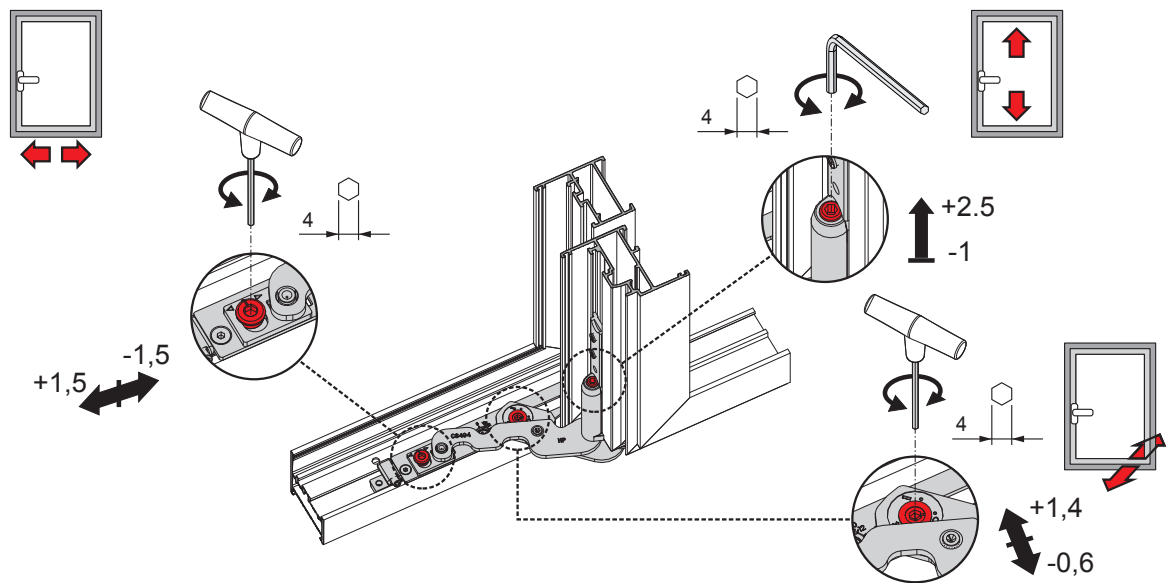
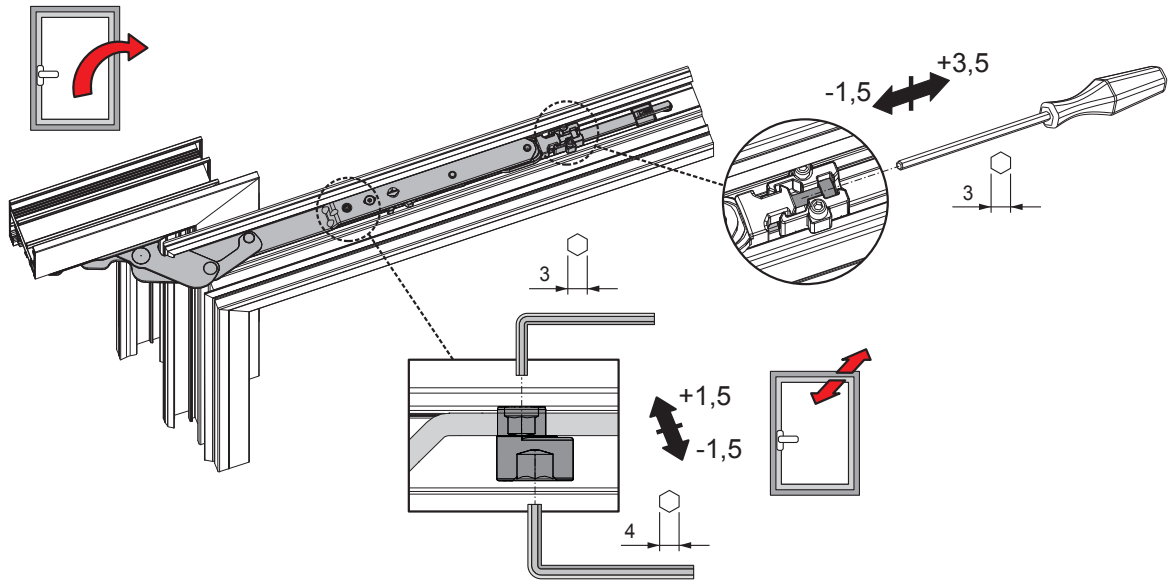

Item code	Description	PROFILE CROSS - SECTION	Range (mm)	Version	A (mm)	Hand	Base Raw	Anodised Elox	Painted	Trend/Gold Brass	Pieces per pack
0436511	CHIC 150 - T1 ARM T&T KIT	C001-C002-C003-C004-C005-C006	L 470 ÷ 700	Micro	-	RX	X				10
0436521	CHIC 150 - T1 ARM T&T KIT	C001-C002-C003-C004-C005-C006	L 470 ÷ 700	Micro	-	LX	X				10
0436611	CHIC 150 - T2 ARM T&T KIT	C001-C002-C003-C004-C005-C006	L 600 ÷ 1600	Micro	148÷178	RX	X				10
0436621	CHIC 150 - T2 ARM T&T KIT	C001-C002-C003-C004-C005-C006	L 600 ÷ 1600	Micro	148÷178	LX	X				10

CHIC 3D 150 FASTENING MECHANISMS

Functions

Tilt-and-Turn fastening mechanisms for cremone, window handle and NP SUPRA window handle, available in the Standard and Logica versions.

Materials

Drive, drive rod, mechanism bolt tip and strikers in zamak with GS Silver Plus finish (up to 500 h of corrosion resistance).

Screws and grub screws in stainless steel.

Polyamide raiser.

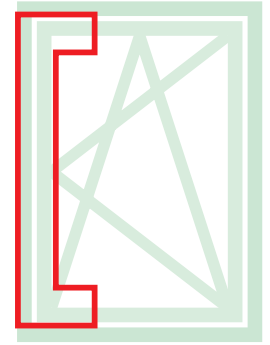

Online data sheet

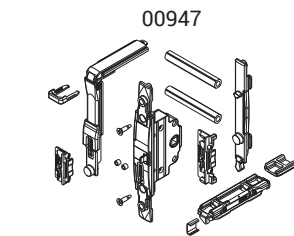

00947



0395501

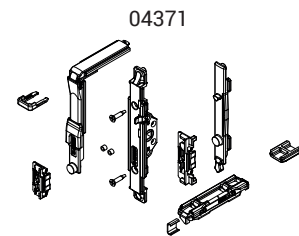

04371

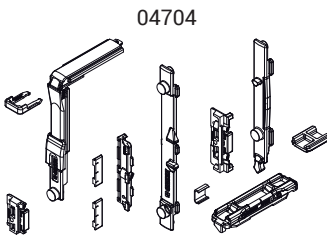

04704

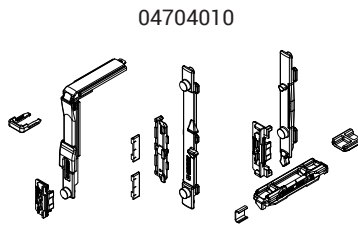

04704010

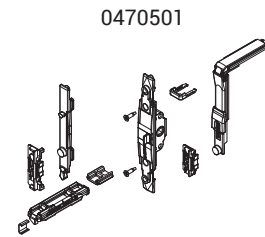

0470501

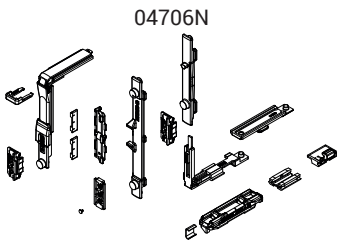

04706N

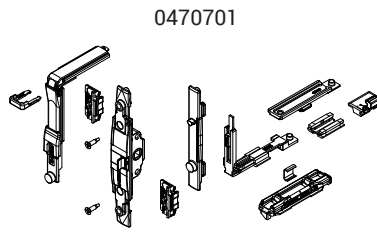

0470701

Item code	Description	PROFILE CROSS - SECTION	Mechanism	Version	Base Raw	Anodised Elox	Painted	Trend/Gold Brass	Pieces per pack
00947	T/T M 180 MOVEMENT FASTENING MECHANISM	C001-C002-C003-C005-C006-C013-C014-C015-C017	Window handle	-	X				10
0395501	T/T FASTENING MECHANISM	C001-C002-C003-C005-C006-C013-C014-C015-C017	NP SUPRA	-	X				10
04371	FASTENING MECHANISM T/T MOVEMENT M 180	C001-C002-C004-C005-C006-C013-C014-C015-C016-C017	Window handle - SUPRA 7	-	X				10
04704	T/T FASTENING MECHANISM	C001-C002-C003-C005-C006-C013-C014-C015-C016-C017	Cremone	-	X				10
04704010	T/T FASTENING MECHANISM	C001-C003	Cremone	-	X				10
0470501	T/T M 180 FASTENING MECHANISM	C001-C002-C004-C005-C006-C013-C014-C015-C016-C017	Window handle - SUPRA 7	-	X				10
04706N	T/T LOGICA FASTENING MECHANISM	C001-C002-C003-C005-C006-C013-C014-C015-C016-C017	Cremone	Logica	X				10
0470701	T/T M 180 LOGICA FASTENING MECHANISM	C001-C002-C004-C005-C006-C013-C014-C015-C016-C017	Window handle	Logica	X				10

CHIC 3D 150 ADDITIONAL FASTENING MECHANISMS AND ACCESSORIES

Functions

The additional fasteners make it possible to add further fastening elements that either increase the dimensions of the casement or that can be used when locking points are needed on the cross beams or hinge-side upright.

Technical Features

On the basis of the dimensions of the casement, additional fasteners (for H>1200 mm and W>1000 mm) and the additional arm (which is mandatory for W>1000 mm) are to be used in combination with this mechanism.

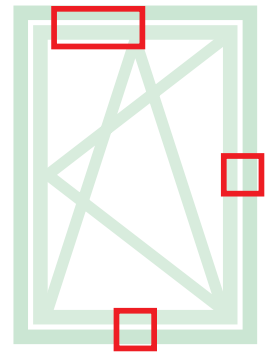

Online data sheet



02030K

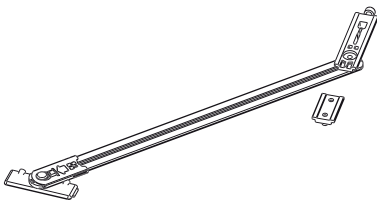

03535

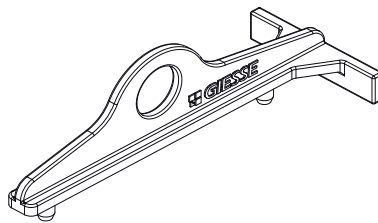

04024K

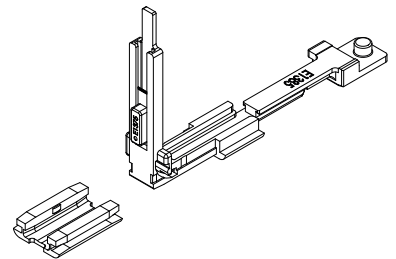

04301K

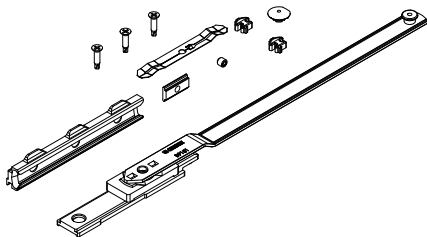

04357

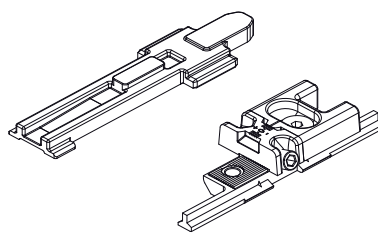

04770K

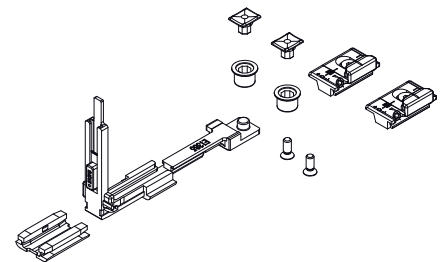

04777K

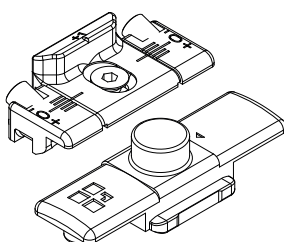

Mandatory to use the FRIZ arm

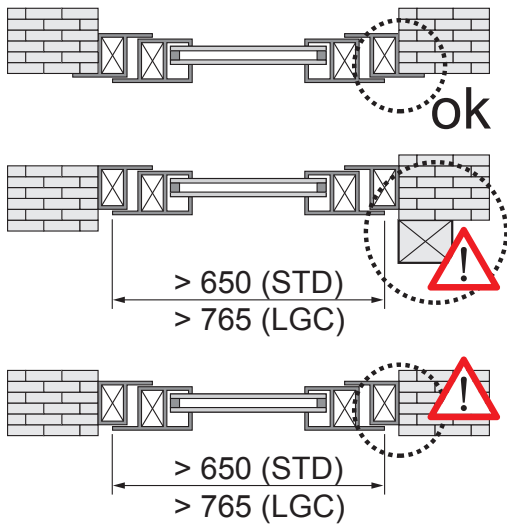

FRIZ arm positioning

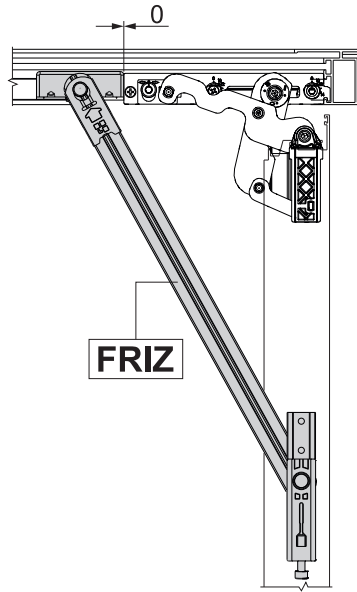

Opening angle with FRIZ arm

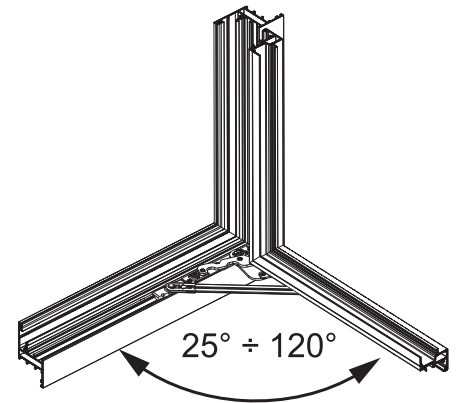

Item code	Description	PROFILE CROSS - SECTION	Range (mm)	Version	Base Raw	Anodised Elox	Painted	Trend/Gold Brass	Pieces per pack
02030K	FRIZ STAY LIMITATION ARM	C001-C002-005-C011-C013-C014-C015-C016-C017	See picture	-	X				10
03535	CHIC - TEMPLATE FOR TILT-AND-TURN	C001-C002-C003-C005-C006	-	-	X				10
04024K	CORNER DRIVE FOR FUTURA BURGLAR-PROOF FUNCTION	C001-C002-C003-C013-C014-C015-C016-C017	-	-	X				10
04301K	T/T FUTURA ADDITIONAL ARM	C001-C002-C003-C005-C006-C011-C013-C014-C015-C016-C017	W > 1000	-	X				5
04357	CHIC - ARM ADDITIONAL FASTENING MECHANISM	C001-C002-C003-C005-C006	-	-	X				10
04770K	FUTURA ADDITIONAL FASTENING MECHANISM	C001-C002-C003-C005-C006-C013-C014-C015-C016-C017	H > 1200 L > 1000	-	X				10
04777K	FUTURA ADDITIONAL FASTENING MECHANISM	C001-C002-C003-C005-C006-C011-C013-C014-C015-C016-C017	H > 1200 L > 1000	Logica	X				50

SECONDARY SASH HINGE SET FOR CHIC 3D 150

Functions

Set of hinges (top and bottom) for side-hung or secondary sash with tilt-and-turn CHIC 3D 150.

Technical Features

Sash opening to 180°.

Maximum load capacity 150 kg.

Assembly is simple, fast and easy using the special pre-assembled cams.

When there is an additional fastening mechanism, you need to use the CHIC fastening element.

Both hinges are adjustable (3D).

If opening is obstructed, you need to use the FRIZ limitation arm.

CAUTION: This hinge is designed to be used only on inward opening casements and is not suitable for outward opening casements.

Materials

Corner support made of zamak

Connecting brackets and hinge plates made of zinc plated steel

Pins made of 304 grade stainless steel and aluminium bronze

Cams made of zinc plated steel

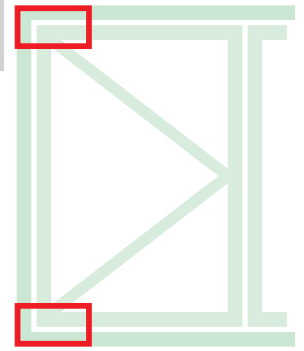

Online data sheet



0436421

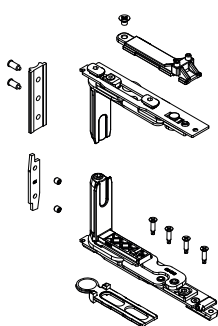

0436411

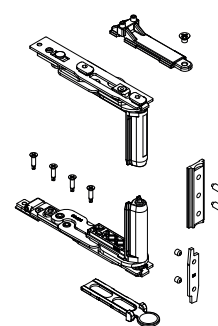

Mandatory to use the FRIZ arm

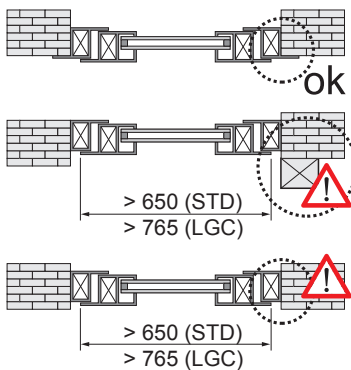

FRIZ arm positioning

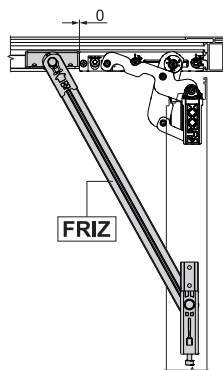

Opening angle with FRIZ arm

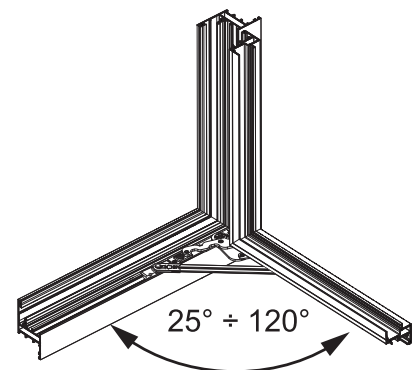

Item code	Description	PROFILE CROSS - SECTION	Hand	Base Raw	Anodised Elox	Painted	Trend/Gold Brass	Pieces per pack
0436411	CHIC - SASH HINGE SET	C001-C002-C003-C004-C005-C006	RX	X				10
0436421	CHIC - SASH HINGE SET	C001-C002-C003-C004-C005-C006	LX	X				10

CONFIGURATION EXAMPLES

CHIC 3D 150

Micro configuration with Cremone

MAIN SASH			
Sash width	470 ÷ 700	600 ÷ 1000	1001 ÷ 1600
Hinges + Arm	0436511-0436521	0436611-0436621	0436611-0436621
Mechanism	04704 - 04704010	04704 - 04704010	04704 - 04704010
Additional arm	-	-	04301K
Cremone	01039 - 01094 - 01084	01039 - 01094 - 01084	01039 - 01094 - 01084
SECONDARY SASH			
Hinges	0436411-0436421	0436411-0436421	0436411-0436421
Adjustable bolt	02168K	02168K	02168K
Single striker	01348	01348	01348

Micro configuration with window handle

MAIN SASH			
Sash width	470 ÷ 700	600 ÷ 1000	1001 ÷ 1600
Hinges + Arm	0436511-0436521	0436611-0436621	0436611-0436621
Mechanism	0470501	0470501	0470501
Additional arm	-	-	04301K
Window handle	02476 - 02415 - 00997	02476 - 02415 - 00997	02476 - 02415 - 00997
SECONDARY SASH			
Hinges	0436411-0436421	0436411-0436421	0436411-0436421
Adjustable bolt	02168K	02168K	02168K
Single striker	01348	01348	01348

Micro configuration with NP Supra

MAIN SASH			
Sash width	470 ÷ 700	600 ÷ 1000	1001 ÷ 1600
Hinges + Arm	0436511-0436521	0436611-0436621	0436611-0436621
Mechanism	03955	03955	03955
Additional arm	-	-	04301K
NP Supra	03962 - 03963	03962 - 03963	03962 - 03963
SECONDARY SASH			
Hinges	0436411-0436421	0436411-0436421	0436411-0436421
Adjustable bolt	02168K	02168K	02168K
Single striker	01348	01348	01348

Logica micro configuration with Cremone

MAIN SASH			
Sash width	470 ÷ 700	600 ÷ 1000	1001 ÷ 1600
Hinges + Arm	0436511-0436521	0436611-0436621	0436611-0436621
Mechanism	04706N - 04706010N	04706N - 04706010N	04706N - 04706010N
Additional arm	-	-	04301K
Cremone	01194 - 01087	01194 - 01087	01194 - 01087
SECONDARY SASH			
Hinges	0436411-0436421	0436411-0436421	0436411-0436421
Adjustable bolt	02168K	02168K	02168K
Single striker	01348	01348	01348

Logica configuration with window handle

MAIN SASH			
Sash width	470 ÷ 700	600 ÷ 1000	1001 ÷ 1600
Hinges + Arm	0436511-0436521	0436611-0436621	0436611-0436621
Mechanism	0470701	0470701	0470701
Additional arm	-	-	04301K
Window handle	02486	02486	02486
SECONDARY SASH			
Hinges	0436411-0436421	0436411-0436421	0436411-0436421
Adjustable bolt	02168K	02168K	02168K
Single striker	01348	01348	01348

CHIC 3D 130 ERRE

Functions

Complete system for the construction of concealed tilt-and-turn windows with load capacities of up to 130 kg and with 180° sash opening. Available in the standard, logic and micro-ventilation versions.

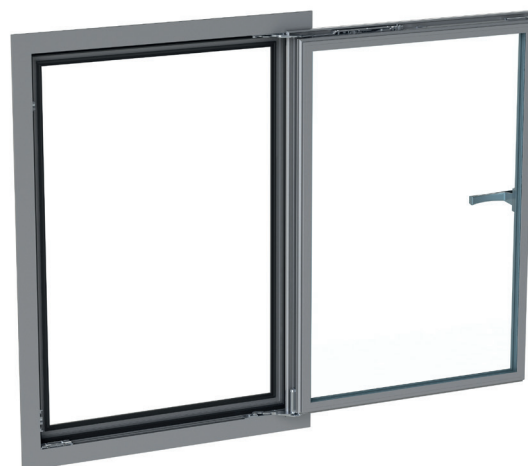

CHIC 130

Technical Features

Making a CHIC 3D 130 ERRE Tilt-and-Turn mechanism requires:

1. Set of hinges + arms
2. Set of mechanisms for cremones, window handles and SUPRA 7 window handles
3. Cremone, window handle or SUPRA 7 window handle (available in different models to choose from in the specific catalogue section)

Adjustments

The adjustments are micrometric and independent.

Standard microventilation

Micro-ventilation enables having simultaneously both the tilt-and-turn position and micro-ventilation (precision opening of the sash) on the casement, for better air exchange.

Logica

The logical operation consists in first tilt-and-turn opening (with the cremone at 90°) and secondly side-hung opening (with the cremone at 180°). Its use is particularly recommended in public buildings (schools, hospitals, etc.) in combination with a cremone with a key in order to have only tilt-and-turn window opening for safety reasons and to allow full opening only for staff with the key.

Production micro-ventilation with standard opening

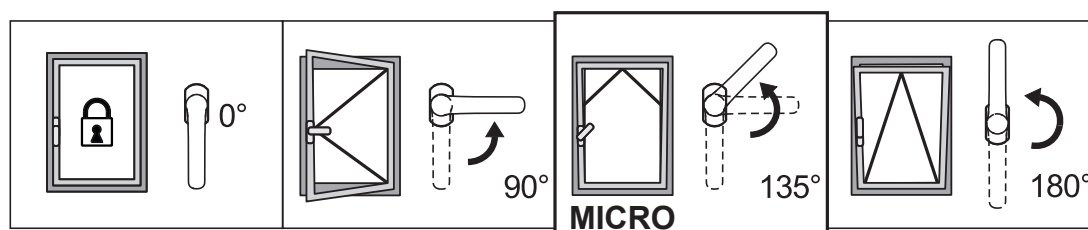

Production micro-ventilation with Logica opening

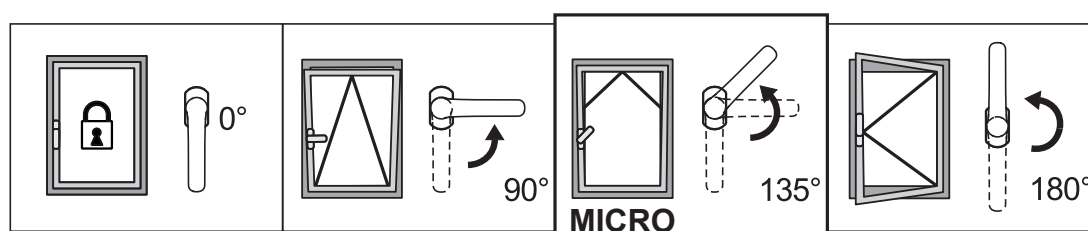

ADJUSTMENTS [mm]

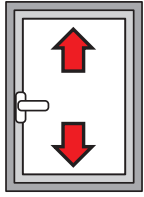

Height:
+2.5 / -1

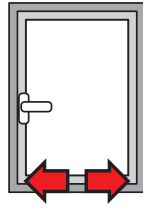

Side:
±1.5

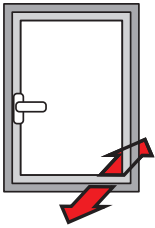

Bottom hinge compression:
+1.4 / -0.6

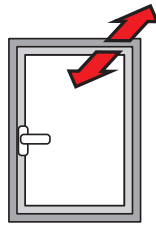

Top hinge compression:
±1.5

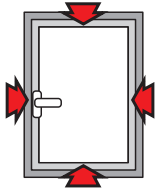

Striker compression:
±1,2

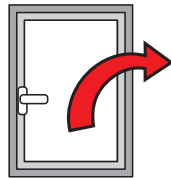

Sash fall:
+3.5 / -1.5

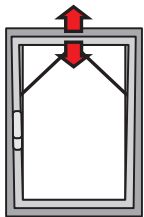

Micro-ventilation:
+3,6 / -0,6

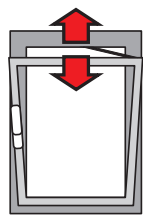

T2 arm opening:
148 ÷ 178

Table of maximum glass thickness [mm]

2800	35	29	25	22	19	17	16	14	13	12	12	
2700	37	31	26	23	20	18	17	15	14	13	12	
2600	39	32	28	24	21	19	18	16	15	14	13	12
2500	43	35	30	27	24	21	19	18	16	15	14	13
2400	43	35	30	27	24	21	19	18	16	15	14	13
2300	44	37	32	28	25	22	20	18	17	16	15	14
2200	46	39	33	29	26	23	21	19	18	17	15	14
2100	49	40	35	30	27	24	22	20	19	17	16	15
2000	51	43	36	32	28	26	23	21	20	18	17	16
1900	54	45	38	34	30	27	24	22	21	19	18	17
1800	57	47	40	35	31	28	26	24	22	20	19	18
1700	60	50	43	38	33	30	27	25	23	21	20	18
1600	60	53	46	40	35	32	29	27	25	23	21	18
1500	60	57	49	43	38	34	31	28	26	24	21	18
1400	60	60	52	46	40	36	33	30	28	24	21	18
1300	60	60	56	49	44	39	36	33	28	24	21	18
1200	60	60	60	53	47	43	39	33	28	24	21	
1100	60	60	60	58	52	46	39	33	28	24		
1000	60	60	60	60	57	47	39	33	28			
900	60	60	60	60	58	47	39	33				
800	60	60	60	60	58	47	39					
700	60	60	60	60	58	47						
600	500	600	700	800	900	1000	1100	1200	1300	1400	1500	1600
450												

Table of maximum load capacity [kg]

2800	124	124	124	124	124	124	124	124	124	124	124		
2700	126	126	126	126	126	126	126	126	126	126	126		
2600	128	128	128	128	128	128	128	128	128	128	128	128	
2500	130	130	130	130	130	130	130	130	130	130	130	130	
2400	130	130	130	130	130	130	130	130	130	130	130	130	
2300	130	130	130	130	130	130	130	130	130	130	130	130	
2200	130	130	130	130	130	130	130	130	130	130	130	130	
2100	130	130	130	130	130	130	130	130	130	130	130	130	
2000	130	130	130	130	130	130	130	130	130	130	130	130	
1900	130	130	130	130	130	130	130	130	130	130	130	130	
1800	130	130	130	130	130	130	130	130	130	130	130	130	
1700	130	130	130	130	130	130	130	130	130	130	130	127	
1600	130	130	130	130	130	130	130	130	130	130	127	119	
1500	130	130	130	130	130	130	130	130	130	128	119	112	
1400	130	130	130	130	130	130	130	130	129	119	111	104	
1300	130	130	130	130	130	130	130	129	119	111	103	97	
1200	130	130	130	130	130	130	130	119	110	102	95		
1100	130	130	130	130	130	130	119	109	101	94			
1000	130	130	130	130	130	119	108	99	92				
900	130	130	130	130	119	107	98	90					
800	130	130	130	119	106	95	87						
700	130	130	119	104	93	84							
600	450	500	600	700	800	900	1000	1100	1200	1300	1400	1500	1600

CHIC 130

CHIC 3D 130 ERRE standard

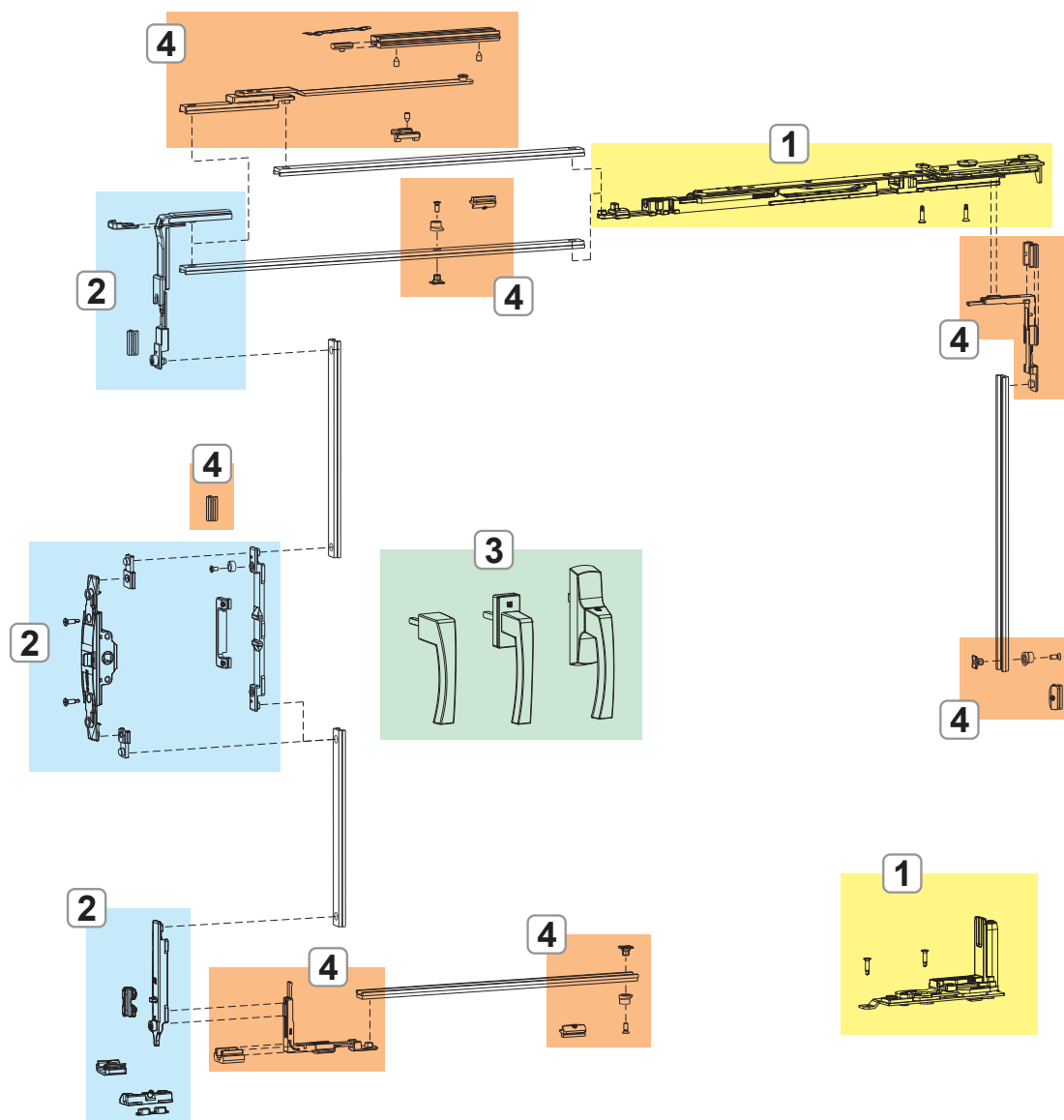

1. CHIC 3D 130 HINGES AND ARMS ERRE
2. CHIC 3D 130 ERRE FASTENING MECHANISMS
3. NP SUPRA CREMONES, WINDOW HANDLES AND MECHANISMS
4. CHIC 3D 130 ADDITIONAL FASTENING MECHANISMS AND HARDWARE

CHIC 130

CHIC 3D 130 ERRE logica

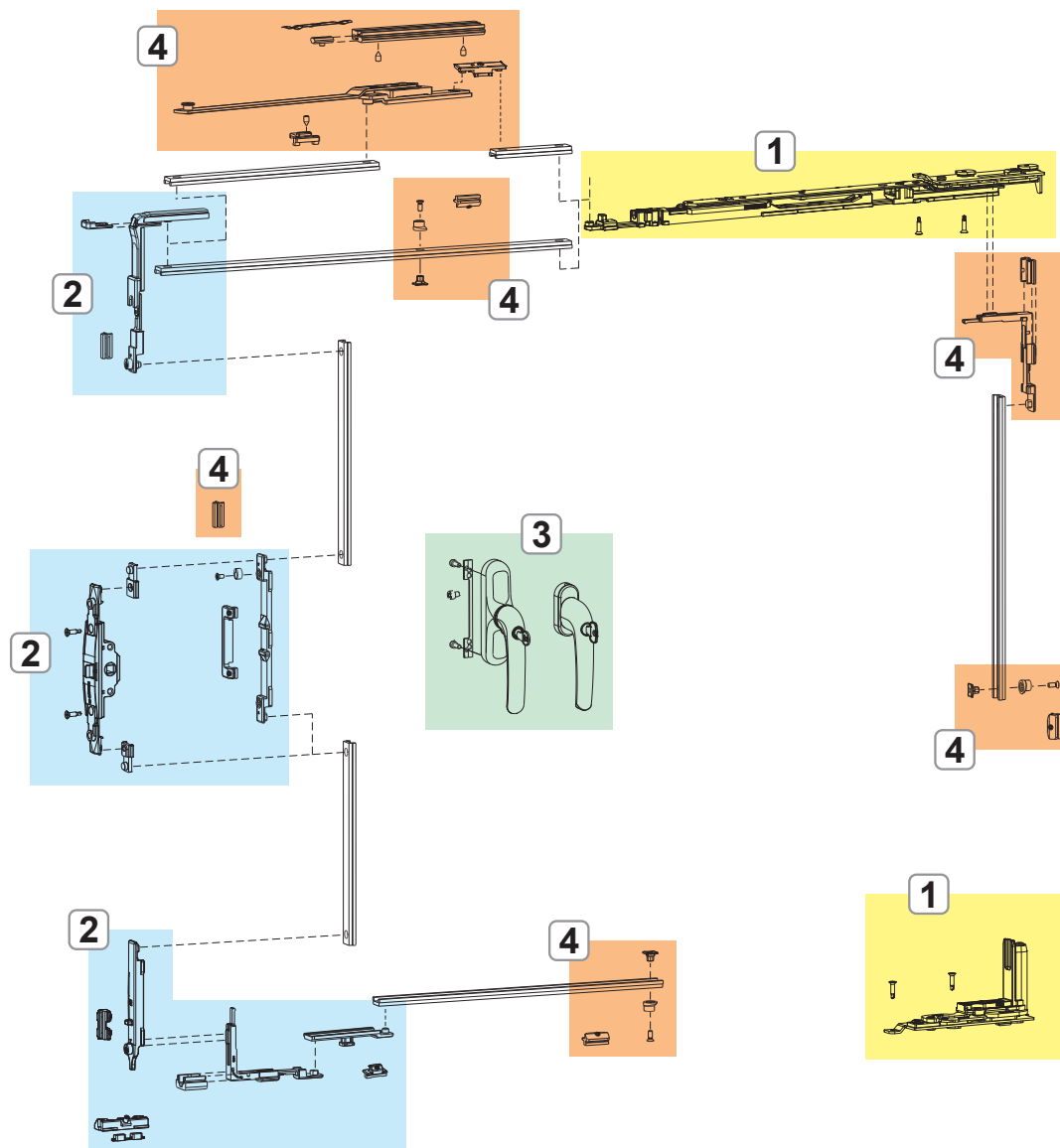

- 1. CHIC 3D 130 HINGES AND ARMS ERRE
- 2. CHIC 3D 130 ERRE FASTENING MECHANISMS
- 3. NP SUPRA CREMONES, WINDOW HANDLES AND MECHANISMS
- 4. CHIC 3D 130 ADDITIONAL FASTENING MECHANISMS AND HARDWARE

CHIC 3D 130 HINGES AND ARMS ERRE

Functions

Set of hinges (top and bottom), completely pre-assembled and ready to be installed on the profile.

Technical Features

They enable tilt-and-turn opening combined with the mechanisms.

Micro-ventilation and logica versions.

The arm is equipped with micro-ventilation as standard (adjustable).

Moving the fastening pawl takes the arm from conventional to logica.

The T2 arm is adjustable: the opening "A" goes from 178 mm (base) to 148 mm.

Materials

Corner support made of zamak

Connecting brackets and hinge plates made of zinc plated steel

Pins made of 304 grade stainless steel and aluminium bronze

Cams made of zinc plated steel

Connecting bracket and arm rod made of 304 grade stainless steel

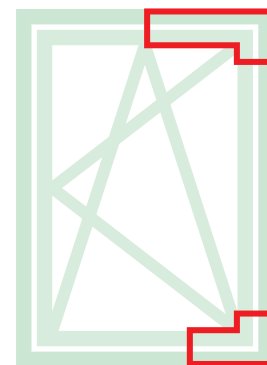

Online data sheet

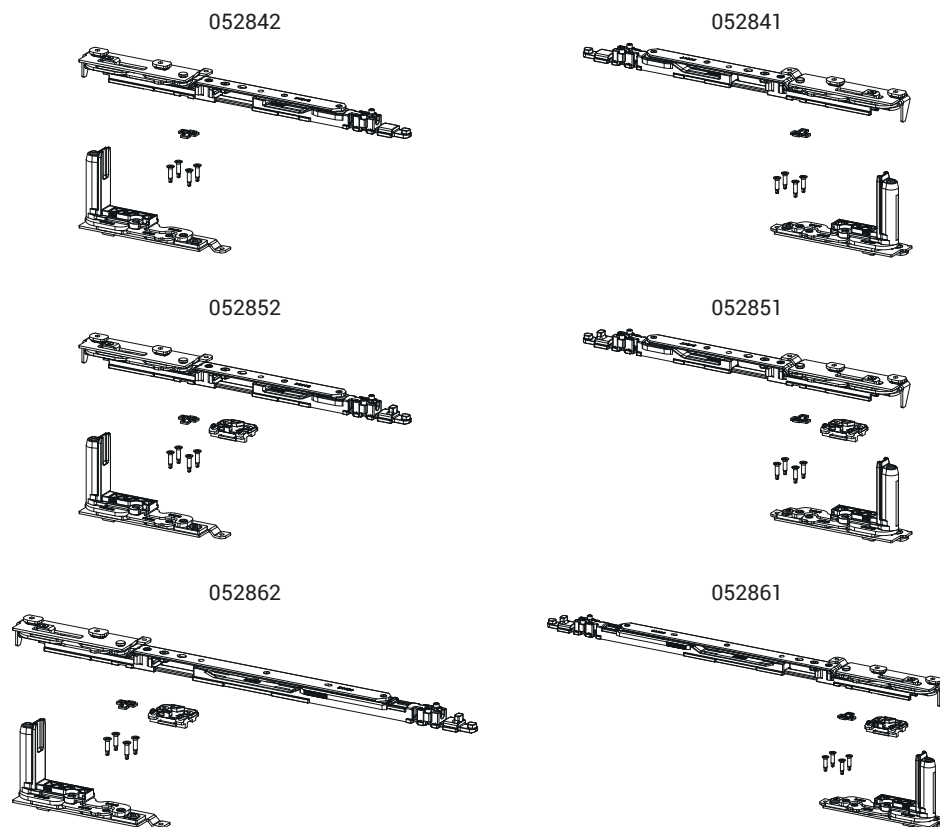

Sash opening

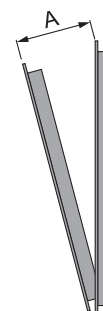

Item code	Description	PROFILE CROSS - SECTION	Range (mm)	Version	A (mm)	Hand	Base Raw	Anodised Elox	Painted	Trend/Gold Brass	Pieces per pack
052841	CHIC 130 ERRE - T1 ARM T&T KIT	C007	L 450 ÷ 475	-	98	RX	X				10
052842	CHIC 130 ERRE - T1 ARM T&T KIT	C007	L 450 ÷ 475	-	98	LX	X				10
052851	CHIC 130 ERRE - T1 ARM T&T KIT	C007	L 475 ÷ 700	Micro	98	RX	X				10
052852	CHIC 130 ERRE - T1 ARM T&T KIT	C007	L 475 ÷ 700	Micro	98	LX	X				10
052861	CHIC 130 ERRE - T2 ARM T&T KIT	C007	L 600 ÷ 1600	Micro	148÷178	RX	X				10
052862	CHIC 130 ERRE - T2 ARM T&T KIT	C007	L 600 ÷ 1600	Micro	148÷178	LX	X				10

CHIC 3D 130 FASTENING MECHANISMS ERRE

Functions

Tilt-and-turn window fastening mechanisms for Cremona, window handle and SUPRA 7 window handle, available in Base and Logica versions.

Materials

Drive, drive rod, mechanism bolt tip and strikers in zamak with GS Silver Plus finish (up to 500 h of corrosion resistance).

Screws and grub screws in stainless steel.

Polyamide raiser.

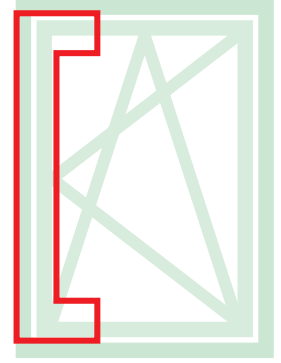

[Online data sheet](#)

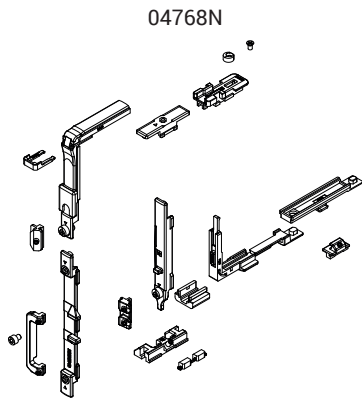
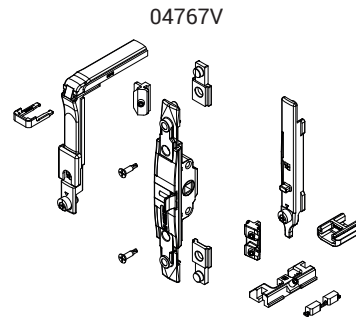
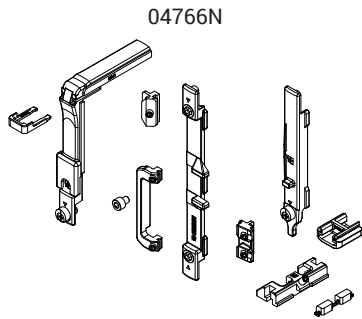

Item code	Description	PROFILE CROSS - SECTION	Mechanism	Version	Base Raw	Anodised Elox	Painted	Trend/Gold Brass	Pieces per pack
04766N	T/T FASTENING MECHANISM	C007	Cremona	-	X				10
04767V	T/T M 180 FASTENING MECHANISM	C007	Window handle	-	X				10
04768N	T/T LOGICA FASTENING MECHANISM	C007	Cremona	Logica	X				10

CHIC 3D 130 ERRE ADDITIONAL FASTENING MECHANISMS AND HARDWARE

Functions

The additional fasteners make it possible to add further fastening elements that either increase the dimensions of the casement or that can be used when locking points are needed on the cross beams or hinge-side upright.

Technical Features

On the basis of the dimensions of the casement, additional fasteners (for H>1200 mm and W>1000 mm) and the additional arm (which is mandatory for W>1000 mm) are to be used in combination with this mechanism.

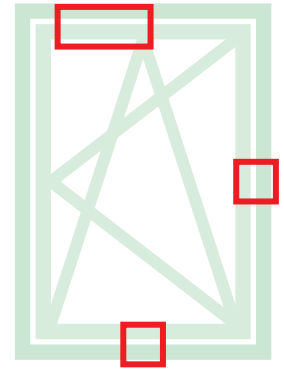

Online data sheet



02034K

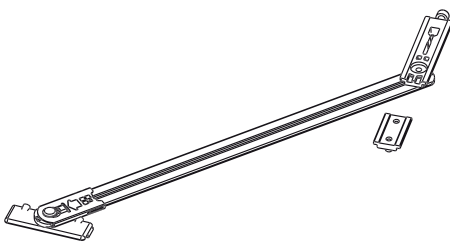

03548

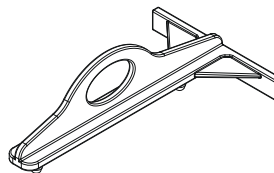

04017K

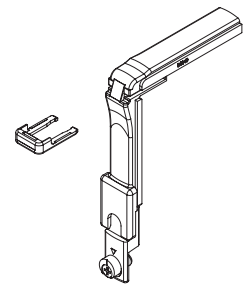

04308K

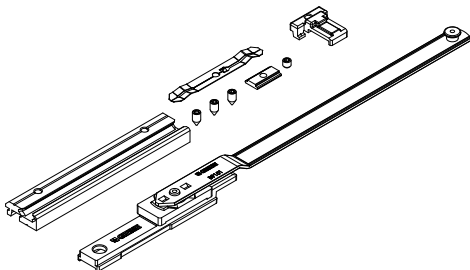

04311

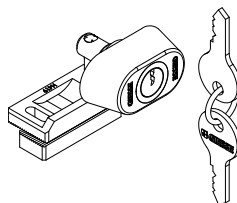

04648K

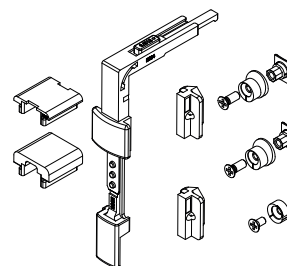

05287

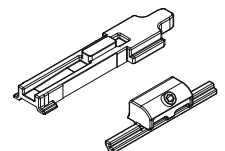

FRIZ arm positioning

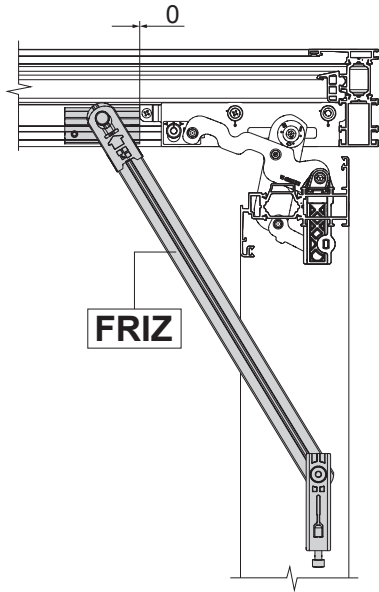

Opening angle with FRIZ arm

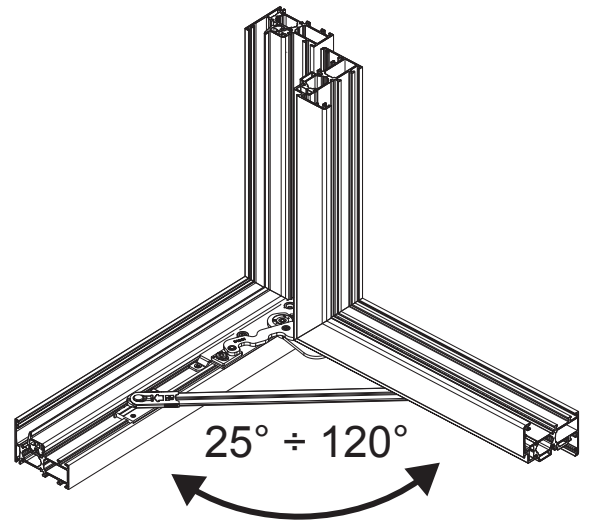

Mandatory to use the FRIZ arm

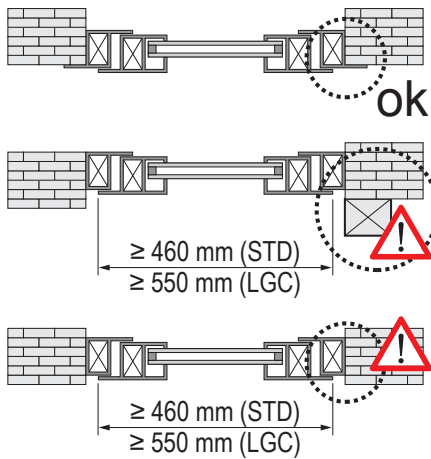

Item code	Description	PROFILE CROSS - SECTION	Range (mm)	Base Raw	Anodised Elox	Painted	Trend/ Gold Brass	Pieces per pack
02034K	FRIZ STAY LIMITATION ARM	C007	See picture	X				10
03548	CHIC ERRE - TEMPLATE FOR TILT-AND-TURN	C007	-	X				10
04017K	FUTURA CORNER DRIVE	C007		X				10
04308K	ADDITIONAL ARM FOR T/T	C007	W > 1000	X				5
04311	SASH OPENING BLOCK LOCK	C001-C002-C003-C005-C006-C007-C008-C009-C010-C013-C014-C015-C017	-	X				10
04648K	VERT./HOR.ADD.FAST. GS999	C007	H > 1200 L > 1000	X				10
05287	CHIC ERRE - ARM ADDITIONAL FASTENING MECHANISM	C007	-	X				10

SECONDARY SASH HINGE SET FOR CHIC 3D 130 ERRE

Functions

Set of hinges (top and bottom) for side-hung or secondary sash with tilt-and-turn CHIC 3D 130 ERRE.

Technical Features

Sash opening to 180°. Maximum load capacity 130 kg. Assembly is simple, fast and easy using the special pre-assembled cams. Both hinges are adjustable (3D). If opening is obstructed, you need to use the FRIZ limitation arm.

Materials

Corner support made of zamak
Connecting brackets and hinge plates made of zinc plated steel
Pins made of 304 grade stainless steel and aluminium bronze
Cams made of zinc plated steel

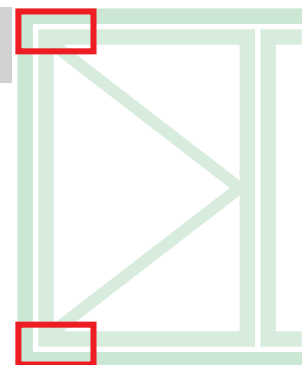

Online data sheet



052832

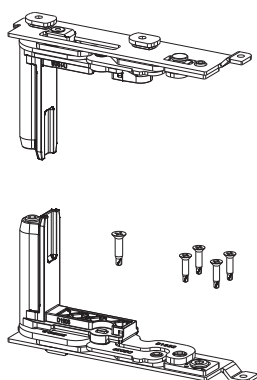

052831

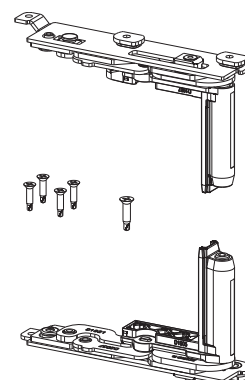

Mandatory to use the FRIZ arm

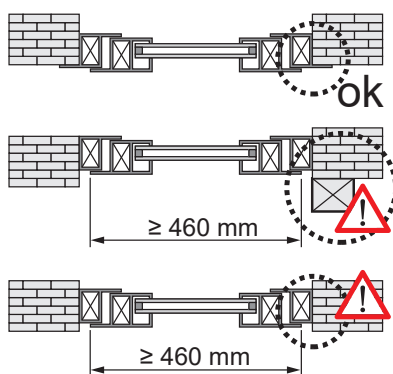

FRIZ arm positioning

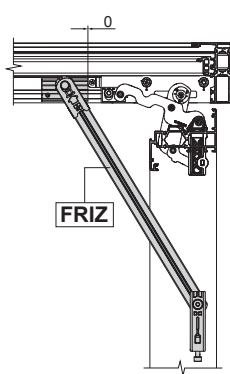

Opening angle with FRIZ arm

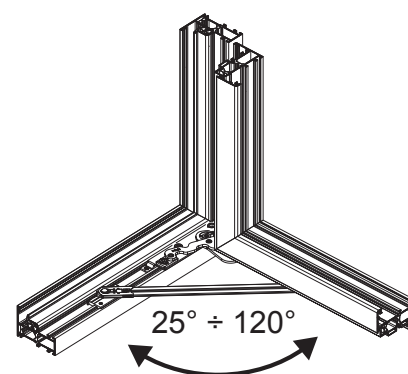

Item code	Description	PROFILE CROSS - SECTION	Hand	Base Raw	Anodised Elox	Painted	Trend/Gold Brass	Pieces per pack
052831	CHIC 130 ERRE - SASH HINGE SET	C007	RX	X				10
052832	CHIC 130 ERRE - SASH HINGE SET	C007	LX	X				10

CONFIGURATION EXAMPLES

CHIC 3D 130 ERRE

Micro configuration with Cremone

MAIN SASH			
Sash width	475 ÷ 700	600 ÷ 1000	1001 ÷ 1600
Hinges + Arm	052851 - 052852	052861 - 052862	052861 - 052862
Mechanism	04766N	04766N	04766N
Additional arm	-	-	04308K
Cremone	01039 - 01094 - 01084	01039 - 01094 - 01084	01039 - 01094 - 01084
SECONDARY SASH			
Hinges	052831 - 052832	052831 - 052832	052831 - 052832
Adjustable bolt	04347	04347	04347
Double striker	01215	01215	01215

Logica micro configuration with Cremone

MAIN SASH			
Sash width	475 ÷ 700	600 ÷ 1000	1001 ÷ 1600
Hinges + Arm	052851 - 052852	052861 - 052862	052861 - 052862
Mechanism	04768N	04768N	04768N
Additional arm	-	-	04308K
Cremone	01194 - 01087	01194 - 01087	01194 - 01087
SECONDARY SASH			
Hinges	052831 - 052832	052831 - 052832	052831 - 052832
Adjustable bolt	04347	04347	04347
Double striker	01215	01215	01215

Micro configuration with window handle

MAIN SASH			
Sash width	475 ÷ 700	600 ÷ 1000	1001 ÷ 1600
Hinges + Arm	052851 - 052852	052861 - 052862	052861 - 052862
Mechanism	04767V	04767V	04767V
Additional arm	-	-	04308K
SUPRA 7 window handle	04153 - 04154 - 04155 - 04156	04153 - 04154 - 04155 - 04156	04153 - 04154 - 04155 - 04156
Window handle	02476 - 02415 - 00997	02476 - 02415 - 00997	02476 - 02415 - 00997
SECONDARY SASH			
Hinges	052831 - 052832	052831 - 052832	052831 - 052832
Adjustable bolt	04347	04347	04347
Double striker	01215	01215	01215

FUTURA 3D 130

Functions

Complete system for the construction of tilt-and-turn windows with load capacities of up to 140 kg.
Available in the standard, logic and microventilation versions.

FUTURA 3D
130

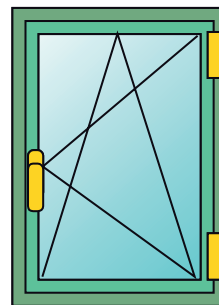

FUTURA 3D
130 micro

FUTURA 3D
130 lgc

FUTURA 3D
130 micro lgc

Technical Features

Making a FUTURA 3D 130 tilt-and-turn window mechanism requires:

- Hinge kit
- Set of fastening mechanisms for Cremones and window handles
- Arms, available in three versions (standard, micro-ventilation and logic)
- Cremona or window handle (available in different models to choose from in the specific catalogue section)

Adjustments

The FUTURA 3D tilt-and-turn window enables micrometric adjustment in every direction, ideal after installing the casement.

Micro-ventilation

Microventilation enables having simultaneously both the tilt-and-turn position and micro-ventilation (precision opening of the sash) on the casement. Available both as standard and with an additional device.

Logica

The logical operation consists in first tilt-and-turn opening (with the cremona at 90°) and secondly side-hung opening (with the cremona at 180°). Its use is particularly recommended in public buildings (schools, hospitals, etc.) in combination with a cremona with a key in order to have only tilt-and-turn window opening for safety reasons and to allow full opening only for staff with the key.

Logica mechanism operation

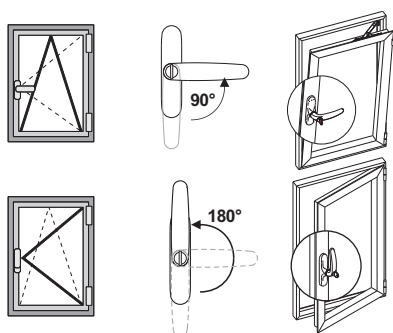

Standard microventilation

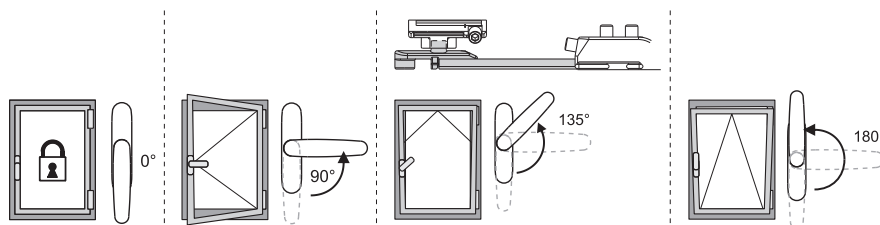

ADJUSTMENTS [mm]

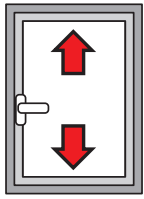

Height:
+1.5 / -0.5

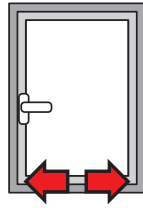

Side:
±1

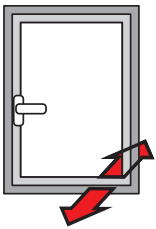

Bottom hinge compression:
±0.3

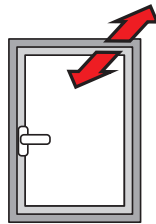

Top hinge compression:
±1.5

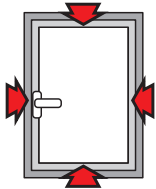

Striker compression:
±1.8

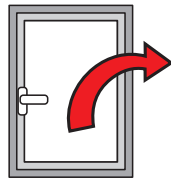

Sash fall:
+3.5 / -1.5

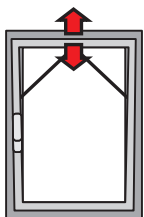

Micro-ventilation:
+3.6 / -1.8

Table of maximum glass thickness [mm]

3000	35	28	24	21	19	17	15	14	13	12	11	11	10	
2900	35	29	25	22	20	18	16	15	14	13	12	11	10	10
2800	36	30	26	23	20	18	17	15	14	13	12	11	11	10
2700	38	31	27	24	21	19	17	16	15	13	13	12	11	10
2600	39	33	28	25	22	20	18	16	15	14	13	12	12	11
2500	44	37	31	27	24	22	20	18	17	16	15	14	13	11
2400	46	38	33	29	25	23	21	19	18	16	15	14	13	12
2300	48	40	34	30	27	24	22	20	18	17	16	15	14	12
2200	50	42	36	31	28	25	23	21	19	18	17	16	15	13
2100	50	44	37	33	29	26	24	22	20	19	17	16	15	13
2000	50	46	39	34	31	27	25	23	21	20	18	17	16	14
1900	50	48	41	36	32	29	26	24	22	21	19	18	16	14
1800	50	50	44	38	34	31	28	25	23	22	20	18	16	14
1700	50	50	46	40	36	32	29	27	25	23	21	18	16	14
1600	50	50	49	43	38	34	31	29	26	24	21	18	16	14
1500	50	50	50	46	41	37	33	31	27	24	21	18	16	14
1400	50	50	50	49	44	39	36	32	27	24	21	18	16	14
1300	50	50	50	50	47	42	38	32	27	24	21	18		
1200	50	50	50	50	50	46	38	32	27	24	21			
1100	50	50	50	50	50	46	38	32	27	24				
1000	50	50	50	50	50	46	38	32	27					
900	50	50	50	50	50	46	38	32						
800	50	50	50	50	50	46	38							
700	50	50	50	50	50	46								
600	50	50	50	50	50	46								

Table of maximum load capacity [kg]

3000	130	130	130	130	130	130	130	130	130	130	130	130	130	130	
2900	130	130	130	130	130	130	130	130	130	130	130	130	130	130	130
2800	130	130	130	130	130	130	130	130	130	130	130	130	130	130	130
2700	130	130	130	130	130	130	130	130	130	130	130	130	130	130	130
2600	130	130	130	130	130	130	130	130	130	130	130	130	130	130	130
2500	140	140	140	140	140	140	140	140	140	140	140	140	140	140	130
2400	140	140	140	140	140	140	140	140	140	140	140	140	140	140	130
2300	140	140	140	140	140	140	140	140	140	140	140	140	140	140	130
2200	140	140	140	140	140	140	140	140	140	140	140	140	140	140	130
2100	140	140	140	140	140	140	140	140	140	140	140	140	140	140	130
2000	140	140	140	140	140	140	140	140	140	140	140	140	140	140	130
1900	140	140	140	140	140	140	140	140	140	140	140	140	140	140	125
1800	140	140	140	140	140	140	140	140	140	140	140	140	140	133	112
1700	140	140	140	140	140	140	140	140	140	140	140	134	126	118	118
1600	140	140	140	140	140	140	140	140	140	140	135	126	118	111	105
1500	140	140	140	140	140	140	140	140	140	137	127	118	111	104	99
1400	140	140	140	140	140	140	140	138	127	118	110	104	97		
1300	140	140	140	140	140	140	140	128	118	110	103	96			
1200	140	140	140	140	140	140	129	118	109	101	95				
1100	140	140	140	140	140	130	118	108	100	93					
1000	140	140	140	140	140	131	118	108	99	91					
900	140	140	140	133	118	106	97	89							
800	140	140	135	118	105	95	86								
700	140	138	118	104	92	83									

FUTURA 3D
130 micro

Futura 3D 130 traditional

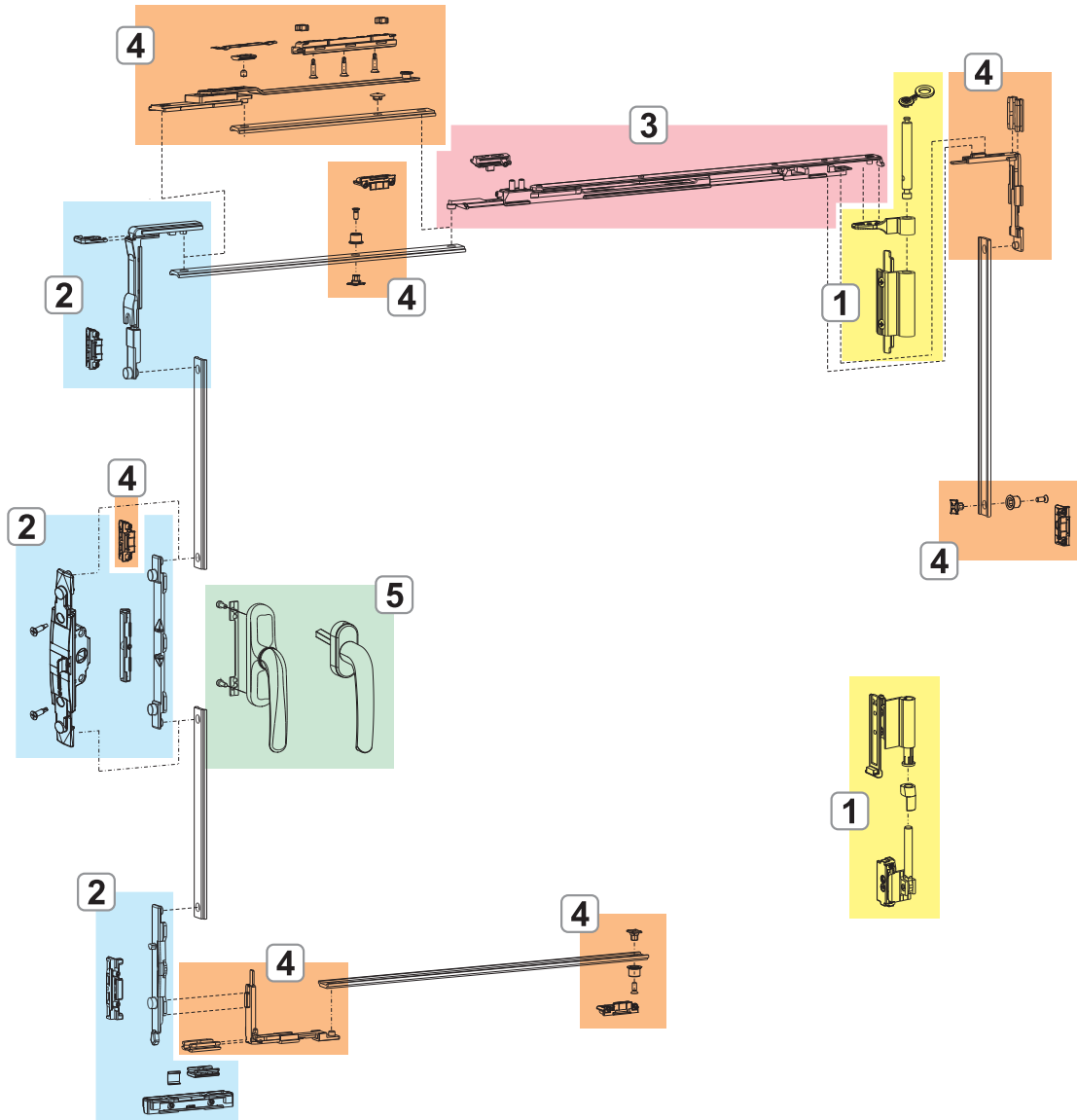

- 1. FUTURA 3D 130 HINGES
- 2. FUTURA 3D 130 FASTENING MECHANISMS
- 3. FUTURA 3D 130 ARMS
- 4. FUTURA 3D 130 ADDITIONAL FASTENING MECHANISMS AND ACCESSORIES
- 5. CREMONES AND WINDOW HANDLES



Futura 3D 130 logica

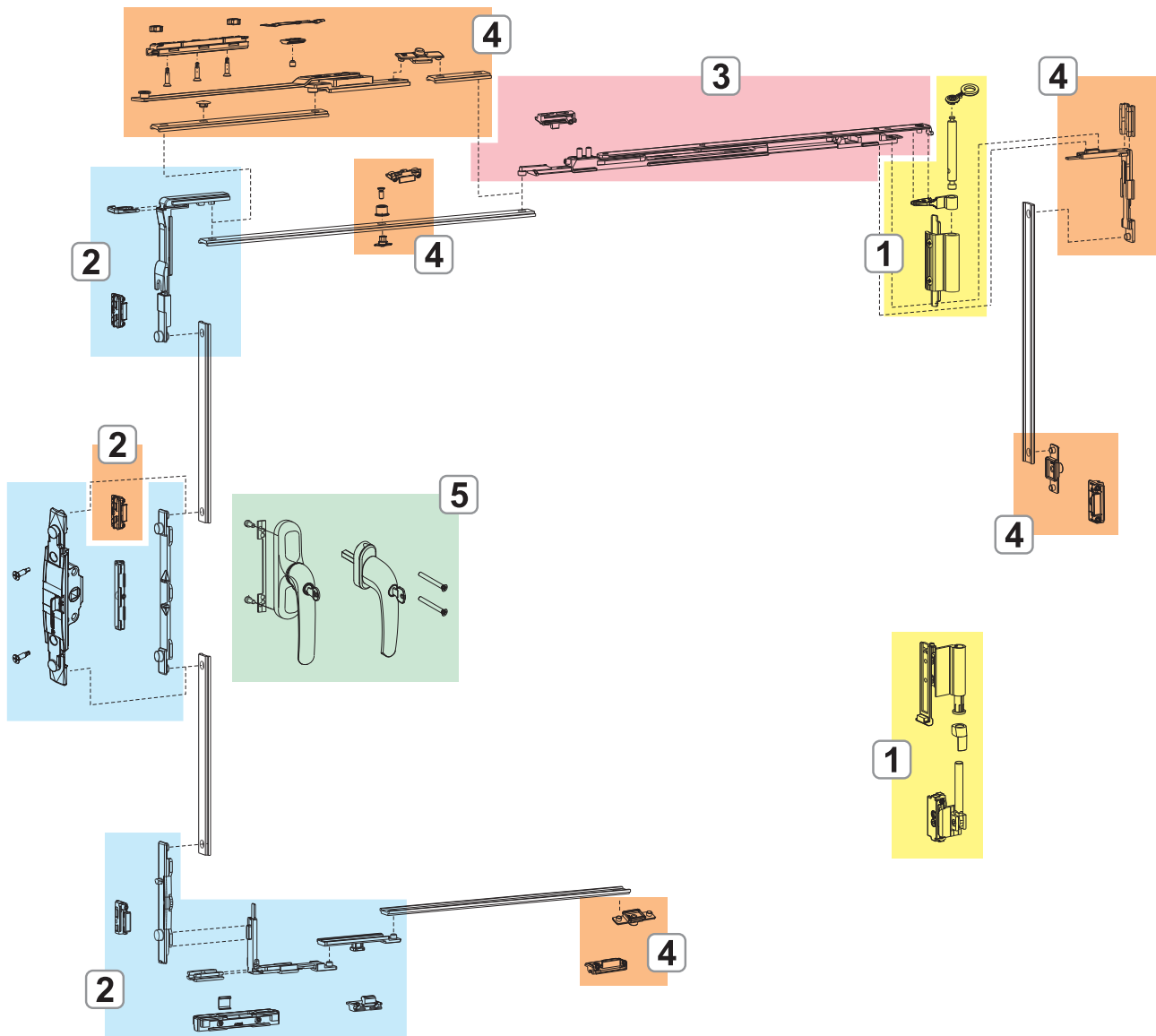

- 1. FUTURA 3D 130 HINGES
- 2. FUTURA 3D 130 FASTENING MECHANISMS
- 3. FUTURA 3D 130 ARMS
- 4. FUTURA 3D 130 ADDITIONAL FASTENING MECHANISMS AND ACCESSORIES
- 5. CREMONES AND WINDOW HANDLES

FUTURA 3D 130 HINGES

Functions

Hinge set (upper and lower), completely pre-assembled and ready to be installed on the profile.

Materials

Body of hinges in extruded aluminium and brass.

Supports in zamak with GS Silver Plus finish (up to 500 hr corrosion resistance).

Pins, screws and grub screws in stainless steel.

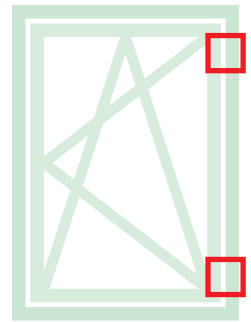

Online data sheet



04711

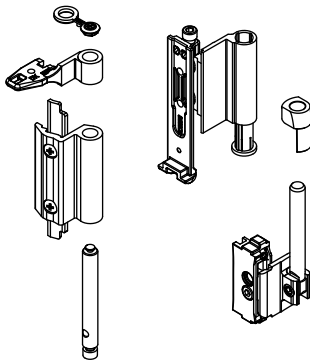

04711010

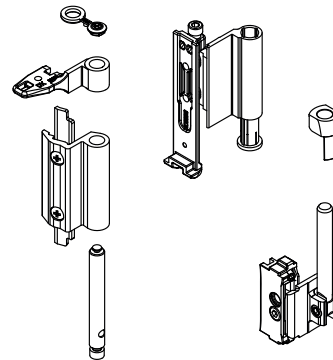

Item code	Description	PROFILE CROSS - SECTION	Base Raw	Anodised Elox	Painted	Trend/Gold Brass	Pieces per pack
04711	HINGE T/T FUTURA 130	C001-C002-C005-C006	X		X	X	10
04711010	HINGE T/T FUTURA 130	C003	X		X		10

FUTURA 3D 130 FASTENING MECHANISMS

Functions

Tilt-and-turn window fastening mechanisms for cremone or window handle, available in Base and Logica versions

Materials

Drive, drive rod, mechanism bolt tip and strikers in zamak with GS Silver Plus finish (up to 500 h of corrosion resistance).

Screws and grub screws in stainless steel.

Polyamide raiser.

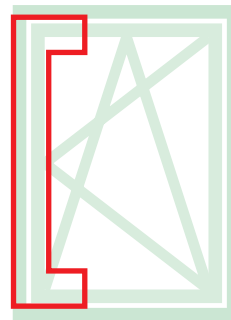

Online data sheet

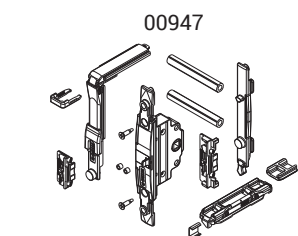

00947

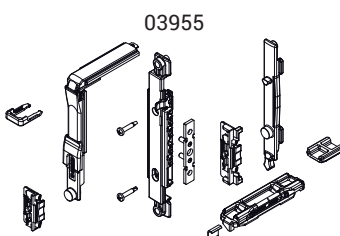

03955

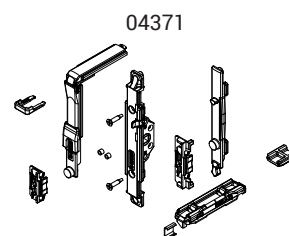

04371

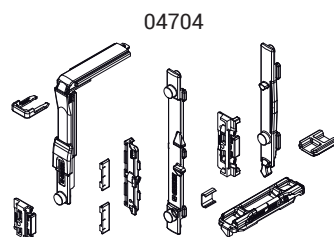

04704

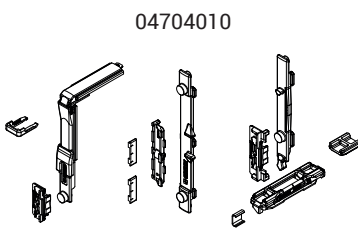

04704010

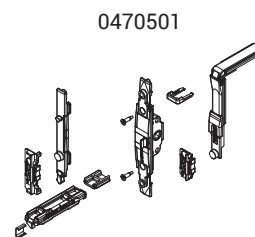

0470501

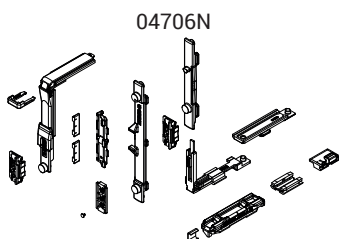

04706N

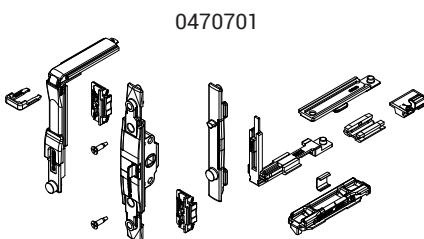

0470701

Item code	Description	PROFILE CROSS - SECTION	Mechanism	Version	Base Raw	Anodised Elox	Painted	Trend/Gold Brass	Pieces per pack
00947	T/T M 180 MOVEMENT FASTENING MECHANISM	C001-C002-C003-C005-C006-C013-C014-C015-C017	Window handle	-	X				10
0395501	T/T FASTENING MECHANISM	C001-C002-C003-C005-C006-C013-C014-C015-C017	NP SUPRA	-	X				10
04371	FASTENING MECHANISM T/T MOVEMENT M 180	C001-C002-C004-C005-C006-C013-C014-C015-C016-C017	Window handle - SUPRA 7	-	X				10
04704	T/T FASTENING MECHANISM	C001-C002-C003-C005-C006-C013-C014-C015-C016-C017	Cremone	-	X				10
04704010	T/T FASTENING MECHANISM	C001-C003	Cremone	-	X				10
0470501	T/T M 180 FASTENING MECHANISM	C001-C002-C004-C005-C006-C013-C014-C015-C016-C017	Window handle - SUPRA 7	-	X				10
04706N	T/T LOGICA FASTENING MECHANISM	C001-C002-C003-C005-C006-C013-C014-C015-C016-C017	Cremone	Logica	X				10
0470701	T/T M 180 LOGICA FASTENING MECHANISM	C001-C002-C004-C005-C006-C013-C014-C015-C016-C017	Window handle	Logica	X				10

FUTURA 3D 130 ARMS

Functions

They enable tilt-and-turn opening in conjunction with the mechanisms and are available in three versions (standard, microventilation and logic).

Materials

Body, fixing block and slider in zamak with GS Silver Plus finish (up to 500 h of corrosion resistance).
Rod, connecting bracket, grub screws and screws in stainless steel.
Stop disk in polyamide.

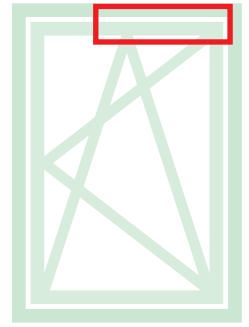

Online data sheet



04202

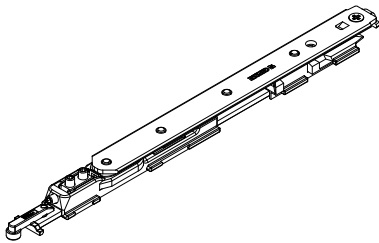

04203

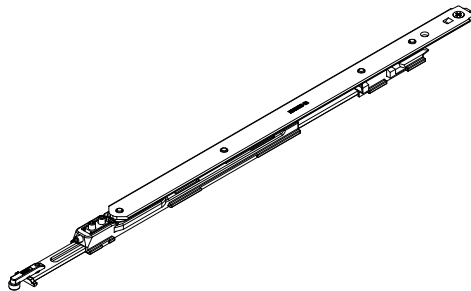

04222

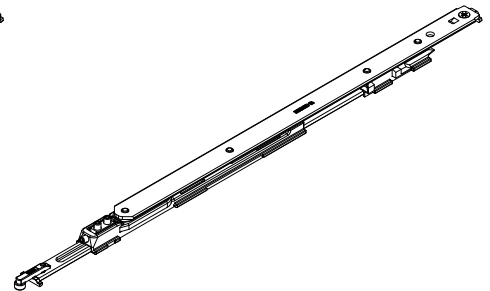

04284

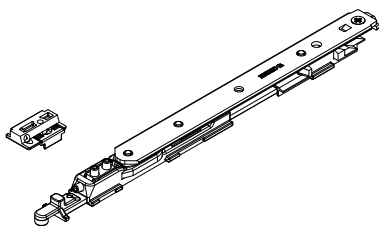

04285

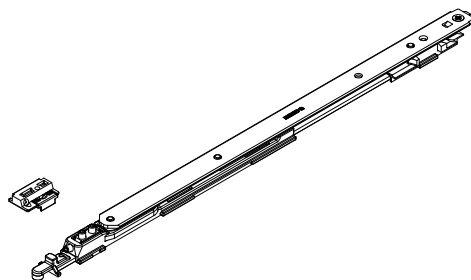

04344

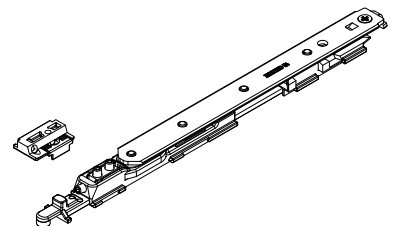

04345

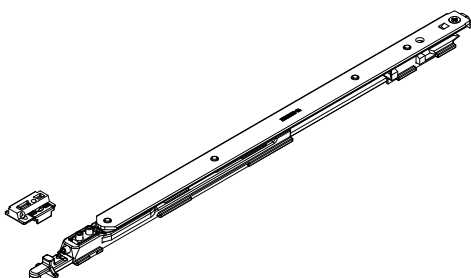

04353

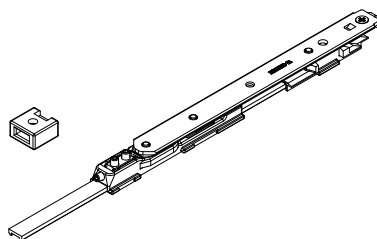

Sash opening

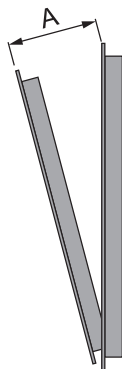

Item code	Description	PROFILE CROSS - SECTION	Range (mm)	Version	A (mm)	Base Raw	Anodised Elox	Painted	Trend/Gold Brass	Pieces per pack
04202	ARM TYPE 1 T/T FUTURA LOGICA 130	C001-C002-C003-C004-C005-C006-C013-C014-C015-C016-C017	W 390 ÷ 700	Logica	120					10
04203	ARM TYPE 2 T/T FUTURA LOGICA 130	C001-C002-C003-C004-C005-C006-C013-C014-C015-C016-C017	W 701 ÷ 1800	Logica	175					10
04222	ARM TYPE 2 T/T FUTURA LOGICA 130	C001-C002-C003-C004-C005-C006-C013-C014-C015-C016-C017	W 701 ÷ 1800	Logica	160					10
04284	ARM T1 130 WITH MICROVENTILATION	C001-C002-C003-C004-C005-C006-C013-C014-C015-C016-C017	W 410 ÷ 700	Micro	120					10
04285	ARM T2 130 WITH MICROVENTILATION	C001-C002-C003-C004-C005-C006-C013-C014-C015-C016-C017	W 701 ÷ 1800	Micro	175					10
04344	ARM T1 130 MICROVENTILATION LOGIC	C001-C002-C003-C004-C005-C006-C013-C014-C015-C016-C017	W 410 ÷ 700	Logica Micro	120					10
04345	ARM T2 130 MICROVENTILATION LOGIC	C001-C002-C003-C004-C005-C006-C013-C014-C015-C016-C017	W 701 ÷ 1800	Logica Micro	175					10
04353	ARM TYPE 0 T/T FUTURA 130	C001-C002-C003-C004-C005-C006-C013-C014-C015-C016-C017	W 350 ÷ 410	-	120					10

FUTURA 3D 130 ADDITIONAL FASTENING MECHANISMS AND ACCESSORIES

Functions

The additional fasteners make it possible to add further fastening elements that either increase the dimensions of the casement or that can be used when locking points are needed on the cross beams or hinge-side upright.

On the basis of the dimensions of the casement, additional fasteners (for H>1200 mm and W>1000 mm) and the additional arm (which is mandatory for W>1000 mm) are to be used in combination with this mechanism.

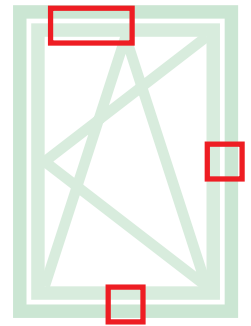

Online data sheet



01299

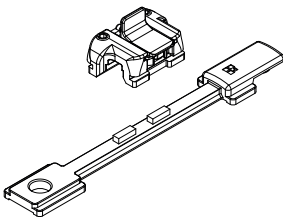

03520

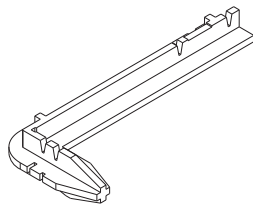

04014K

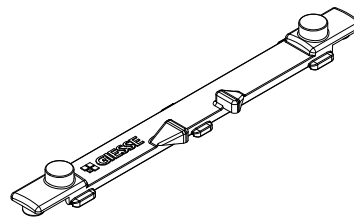

04019K

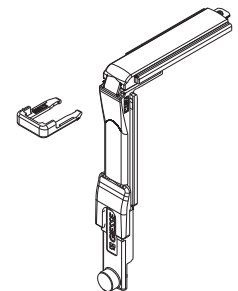

04020K

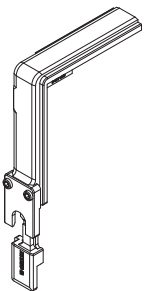

04024K

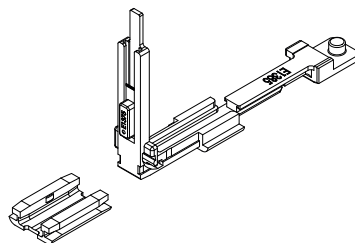

04026K

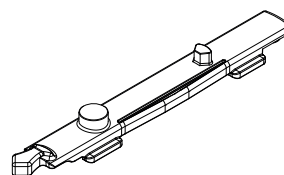

04301K

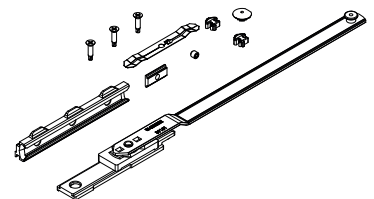

04311

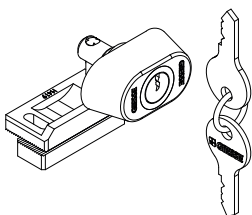

04770K

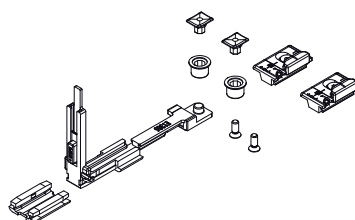

04777K

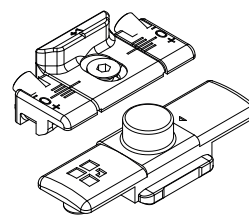

FUTURA 3D 130

Item code	Description	Interface type	Range (mm)	Version	Base Raw	Anodised Elox	Painted	Trend/Gold Brass	Pieces per pack
01299	INCORRECT MOVEMENT SAFETY DEVICE	C001-C002-C003-C004-C005-C006-C013-C014-C015-C016-C017	H > 620 HC > 250	-	X				10
03520	TEMPLATE FOR AR FUTURA	C001-C002-C003-C004-C005-C006-C011-C012-C013-C014-C015-C016-C017	-	-	X				20
04014K	FUTURA T/T DRIVE ROD	C001-C002-C003-C004-C005-C006-C013-C014-C015-C016-C017	-	-	X				10
04019K	CORNER DRIVE GROOVE 15/20 FUTURA	C001-C002-C003-C004-C005-C006-C009-C010-C011-C012-C013-C014-C015-C016-C017	-	-	X				10
04020K	FUTURA CORNER DRIVE	C001-C002-C003-C004-C005-C006-C009-C010-C011-C012-C013-C014-C015-C016-C017-P001-P002-P003-P004-P005-P006-P007-P008-P009-P010	-	-	X				50
04024K	CORNER DRIVE FOR FUTURA BURGLAR-PROOF FUNCTION	C001-C002-C003-C004-C005-C006-C013-C014-C015-C016-C017	-	-	X				10
04026K	FUTURA T/T BOLT TIP	C001-C002-C003-C005-C006-C013-C014-C015-C017	-	-	X				10
04301K	T/T FUTURA ADDITIONAL ARM	C001-C002-C003-C004-C005-C006	W > 1000	-	X				5
04311	SASH OPENING BLOCK LOCK	C001-C002-C003-C004-C005-C006-C007-C013-C014-C015-C016-C017	-	-	X				10
04770K	FUTURA ADDITIONAL FASTENING MECHANISM	C001-C002-C003-C004-C005-C006-C013-C014-C015-C016-C017	H > 1200 L > 1000	-	X				10
04777K	FUTURA ADDITIONAL FASTENING MECHANISM	C001-C002-C003-C004-C005-C006-C013-C014-C015-C016-C017	H > 1200 L > 1000	Logica	X				50

FUTURA 3D 130 SECONDARY SASH

Functions

Adapter for FUTURA 3D 130 tilt-and-turn secondary sash hinges.
 The adapter lets you turn the set of tilt-and-turn hinges into hinges for a secondary sash, keeping the same design, adjustments, dimensions and capacities achievable with a main sash.

Materials

Body of hinges in extruded aluminium and brass.
 Supports in zamak with GS Silver Plus finish (up to 500 hr corrosion resistance).
 Pins, screws and grub screws in stainless steel.

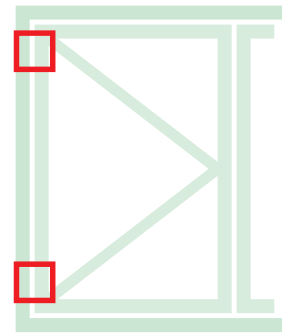

Online data sheet



04728

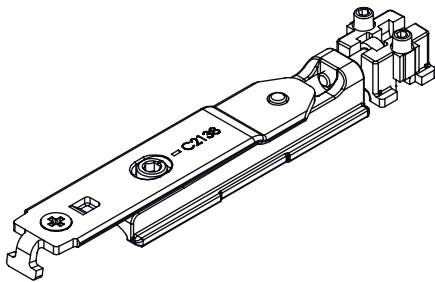

04711

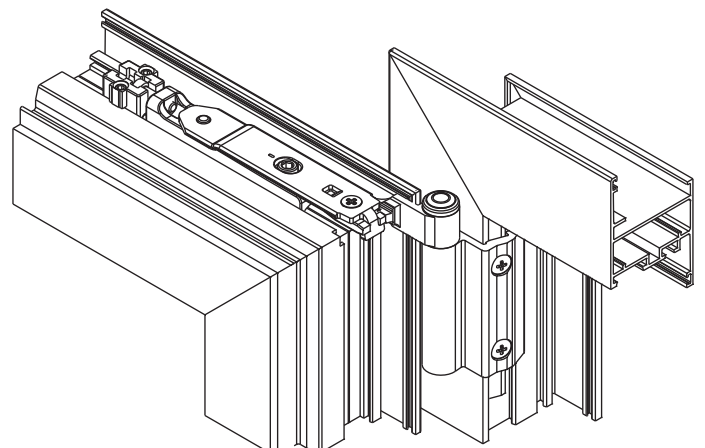
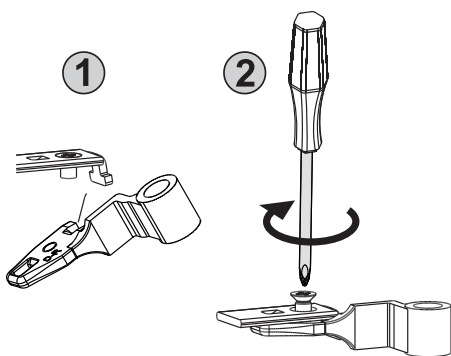
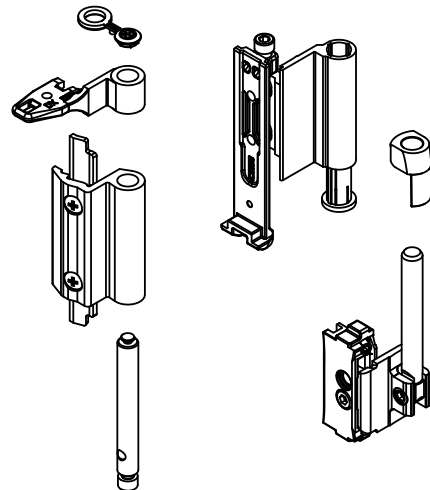

Table of maximum load capacity [kg]

3000																	
2900	130	130	130	130	130	130	130	130	130	130	130	130	130	130	130	130	130
2800	130	130	130	130	130	130	130	130	130	130	130	130	130	130	130	130	130
2700	130	130	130	130	130	130	130	130	130	130	130	130	130	130	130	130	130
2600	130	130	130	130	130	130	130	130	130	130	130	130	130	130	130	130	130
2500	130	130	130	130	130	130	130	130	130	130	130	130	130	130	130	130	130
2400	140	140	140	140	140	140	140	140	140	140	140	140	140	140	140	140	130
2300	140	140	140	140	140	140	140	140	140	140	140	140	140	140	140	140	130
2200	140	140	140	140	140	140	140	140	140	140	140	140	140	140	140	140	130
2100	140	140	140	140	140	140	140	140	140	140	140	140	140	140	140	140	130
2000	140	140	140	140	140	140	140	140	140	140	140	140	140	140	139	125	
1900	140	140	140	140	140	140	140	140	140	140	140	140	140	140	132	118	
1800	140	140	140	140	140	140	140	140	140	140	140	140	140	133	125	112	
1700	140	140	140	140	140	140	140	140	140	140	134	126	118	111	105		
1600	140	140	140	140	140	140	140	140	140	137	127	118	111	104	99		
1500	140	140	140	140	140	140	140	140	140	137	127	118	111	104	99		
1400	140	140	140	140	140	140	140	138	127	118	110	104	97				
1300	140	140	140	140	140	140	140	128	118	110	103	96					
1200	140	140	140	140	140	140	140	129	118	109	101	95					
1100	140	140	140	140	140	130	118	108	100	93							
1000	140	140	140	140	131	118	108	99	91								
900	140	140	140	133	118	106	97	89									
800	140	140	135	118	105	95	86										
700	140	138	118	104	92	83											
600		500	600	700	800	900	1000	1100	1200	1300	1400	1500	1600	1700	1800		

350

Table of maximum load capacity [kg]

3000																	
2900	130	130	130	130	130	130	130	130	130	130	130	130	130	130	130	130	130
2800	130	130	130	130	130	130	130	130	130	130	130	130	130	130	130	130	130
2700	130	130	130	130	130	130	130	130	130	130	130	130	130	130	130	130	130
2600	130	130	130	130	130	130	130	130	130	130	130	130	130	130	130	130	130
2500	130	130	130	130	130	130	130	130	130	130	130	130	130	130	130	130	130
2400	140	140	140	140	140	140	140	140	140	140	140	140	140	140	140	140	130
2300	140	140	140	140	140	140	140	140	140	140	140	140	140	140	140	140	130
2200	140	140	140	140	140	140	140	140	140	140	140	140	140	140	140	140	130
2100	140	140	140	140	140	140	140	140	140	140	140	140	140	140	140	140	130
2000	140	140	140	140	140	140	140	140	140	140	140	140	140	140	139	125	
1900	140	140	140	140	140	140	140	140	140	140	140	140	140	140	132	118	
1800	140	140	140	140	140	140	140	140	140	140	140	140	140	133	125	112	
1700	140	140	140	140	140	140	140	140	140	140	134	126	118	111	105		
1600	140	140	140	140	140	140	140	140	140	137	127	118	111	104	99		
1500	140	140	140	140	140	140	140	140	140	137	127	118	111	104	99		
1400	140	140	140	140	140	140	140	138	127	118	110	104	97				
1300	140	140	140	140	140	140	140	128	118	110	103	96					
1200	140	140	140	140	140	140	140	129	118	109	101	95					
1100	140	140	140	140	140	130	118	108	100	93							
1000	140	140	140	140	131	118	108	99	91								
900	140	140	140	133	118	106	97	89									
800	140	140	135	118	105	95	86										
700	140	138	118	104	92	83											
600		500	600	700	800	900	1000	1100	1200	1300	1400	1500	1600	1700	1800		

350

Item code	Description	PROFILE CROSS - SECTION	Base Raw	Anodised Elox	Painted	Trend/Gold Brass	Pieces per pack
04728	FUTURA 3D 130 SECONDARY SASH ADAPTER	C001-C003	X				10
04711	HINGE T/T FUTURA 130	C001-C002-C003-C005-C006	X		X	X	10

CONFIGURATION EXAMPLES

FUTURA 3D 130

Micro configuration with Cremone

MAIN SASH			
Sash width	410 ÷ 700	701 ÷ 1000	1001 ÷ 1800
Hinges	04711	04711	04711
Mechanism	04704 - 04704010	04704 - 04704010	04704 - 04704010
Arm	04284	04285	04285
Additional arm	-	-	04301K
Cremone	01039 - 01094	01039 - 01094	01039 - 01094
SECONDARY SASH			
Hinges	04711	04711	04711
Adapter	04728	04728	04728
Adjustable bolt	02168K	02168K	02168K
Single striker	01348	01348	01348

Micro configuration with window handle

MAIN SASH			
Sash width	410 ÷ 700	701 ÷ 1000	1001 ÷ 1800
Hinges	04711	04711	04711
Mechanism	0470501	0470501	0470501
Arm	04284	04285	04285
Additional arm	-	-	04301K
Window handle	02476 - 02415 - 00997	02476 - 02415 - 00997	02476 - 02415 - 00997
SECONDARY SASH			
Hinges	04711	04711	04711
Adapter	04728	04728	04728
Adjustable bolt	02168K	02168K	02168K
Single striker	01348	01348	01348

Micro configuration with NP Supra

MAIN SASH			
Sash width	410 ÷ 700	701 ÷ 1000	1001 ÷ 1800
Hinges	04711	04711	04711
Mechanism	0395501	0395501	0395501
Arm	04284	04285	04285
Additional arm	-	-	04301K
NP Supra	03962 - 03963	03962 - 03963	03962 - 03963
SECONDARY SASH			
Hinges	04711	04711	04711
Adapter	04728	04728	04728
Adjustable bolt	02168K	02168K	02168K
Single striker	01348	01348	01348

Logica configuration with Cremone

MAIN SASH			
Sash width	390 ÷ 700	701 ÷ 1000	1001 ÷ 1800
Hinges	04711	04711	04711
Mechanism	04706N - 04706010N	04706N - 04706010N	04706N - 04706010N
Arm	04202	04203	04203
Additional arm	-	-	04301K
Cremone	01192 - 01193	01192 - 01193	01192 - 01193
SECONDARY SASH			
Hinges	04711	04711	04711
Adapter	04728	04728	04728
Adjustable bolt	02168K	02168K	02168K
Single striker	01348	01348	01348

Logica configuration with window handle

MAIN SASH			
Sash width	390 ÷ 700	701 ÷ 1000	1001 ÷ 1800
Hinges	04711	04711	04711
Mechanism	0470701	0470701	0470701
Arm	04202	04203	04203
Additional arm	-	-	04301K
Window handle	02486	02486	02486
SECONDARY SASH			
Hinges	04711	04711	04711
Adapter	04728	04728	04728
Adjustable bolt	02168K	02168K	02168K
Single striker	01348	01348	01348

Logica micro configuration with Cremone

MAIN SASH			
Sash width	410 ÷ 700	701 ÷ 1000	1001 ÷ 1800
Hinges	04711	04711	04711
Mechanism	04706N - 04706010N	04706N - 04706010N	04706N - 04706010N
Arm	04344	04345	04345
Additional arm	-	-	04301K
Cremone	01194 - 01195	01194 - 01195	01194 - 01195
SECONDARY SASH			
Hinges	04711	04711	04711
Adapter	04728	04728	04728
Adjustable bolt	02168K	02168K	02168K
Single striker	01348	01348	01348

FUTURA 3D 170 HP INVISIBLE

FUTURA 3D 170 HP INVISIBLE

Functions

Complete system for the construction of tilt-and-turn windows with load capacities of up to 170 kg. Available in the standard, logic and microventilation versions.

FUTURA 3D
170 HP Invisible

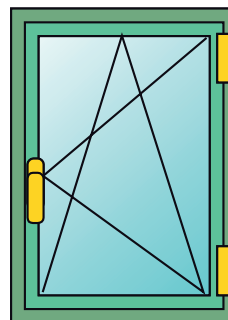

FUTURA 3D
170 HP Invisible

FUTURA 3D
170 HP Invisible lgc

FUTURA 3D
170 HP Invisible micro

Technical Features

Making a FUTURA 3D 170 HP Invisible tilt-and-turn window mechanism requires:

- Hinges and arms kit
- Set of fastening mechanisms for Cremones and window handles
- Cremona or window handle (available in different models to choose from in the specific catalogue section)

Adjustments

The FUTURA 3D tilt-and-turn window enables micrometric adjustment in every direction, ideal after installing the casement.

Micro-ventilation

Microventilation enables having simultaneously both the tilt-and-turn position and micro-ventilation (precision opening of the sash) on the casement. Available both as standard and with an additional device.

Logica

The logical operation consists in first tilt-and-turn opening (with the cremona at 90°) and secondly side-hung opening (with the cremona at 180°). Its use is particularly recommended in public buildings (schools, hospitals, etc.) in combination with a cremona with a key in order to have only tilt-and-turn window opening for safety reasons and to allow full opening only for staff with the key.

Logica mechanism operation

Standard microventilation

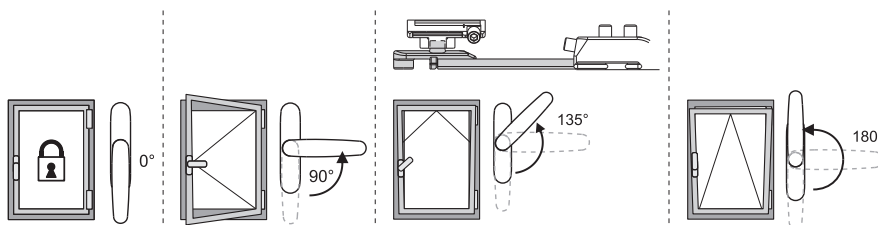
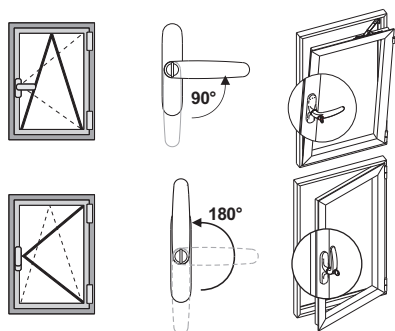

ADJUSTMENTS [mm]

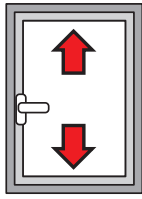

Height:
+1.5 / -0.5

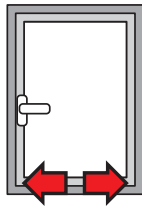

Side:
±1

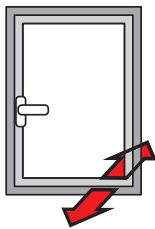

Bottom hinge compression:
±0.3

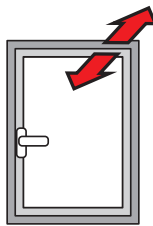

Top hinge compression:
±1.5

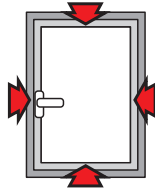

Striker compression:
±1.8

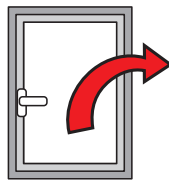

Sash fall:
+3.5 / -1.5

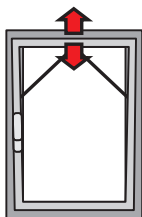

Micro-ventilation:
+3.6 / -1.8

Table of maximum glass thickness [mm]
(weight less than 130 kg)

2500	43	39	36	31	27	24	22	20	18	17	15	14	14	13	
2400	45	41	38	32	28	25	23	21	19	17	16	15	14	13	
2300	47	43	39	34	30	26	24	21	20	18	17	16	15	14	
2200	50	45	41	35	31	28	25	23	21	19	18	17	15	15	
2100	50	47	43	37	33	29	26	24	22	20	19	17	16	15	
2000	50	50	46	39	34	30	27	25	23	21	20	18	17	16	
1900	50	50	48	41	36	32	29	26	24	22	21	19	18	17	
1800	50	50	50	44	38	34	31	28	25	24	22	20	19	18	
1700	50	50	50	46	41	36	33	30	27	25	23	22	20	19	
1600	50	50	50	50	43	39	35	32	29	27	25	23	22	19	
1500	50	50	50	50	46	41	37	34	31	29	27	25	22	19	
1400	50	50	50	50	50	44	40	36	33	31	29	25	22	19	
1300	50	50	50	50	50	48	43	39	36	33	29	25	22		
1200	50	50	50	50	50	50	47	43	39	33	29	25			
1100	50	50	50	50	50	50	50	47	39	33	29				
1000	50	50	50	50	50	50	50	47	39	33					
900	50	50	50	50	50	50	50	47	39						
800	50	50	50	50	50	50	50	47							
700	50	50	50	50	50	50	50								
600	430	500	550	600	700	800	900	1000	1100	1200	1300	1400	1500	1600	1700

Table of maximum load capacity [kg]
(weight less than 130 kg)

2500	130	130	130	130	130	130	130	130	130	130	130	130	130	130	
2400	130	130	130	130	130	130	130	130	130	130	130	130	130	130	
2300	130	130	130	130	130	130	130	130	130	130	130	130	130	130	
2200	130	130	130	130	130	130	130	130	130	130	130	130	130	130	
2100	130	130	130	130	130	130	130	130	130	130	130	130	130	130	
2000	130	130	130	130	130	130	130	130	130	130	130	130	130	130	
1900	130	130	130	130	130	130	130	130	130	130	130	130	130	130	
1800	130	130	130	130	130	130	130	130	130	130	130	130	130	130	
1700	130	130	130	130	130	130	130	130	130	130	130	130	130	130	
1600	130	130	130	130	130	130	130	130	130	130	130	130	130	122	
1500	130	130	130	130	130	130	130	130	130	130	130	130	121	114	
1400	130	130	130	130	130	130	130	130	130	130	130	121	113	106	
1300	130	130	130	130	130	130	130	130	130	130	120	111	104		
1200	130	130	130	130	130	130	130	130	130	119	110	102			
1100	130	130	130	130	130	130	130	130	118	108	100				
1000	130	130	130	130	130	130	130	117	106	98					
900	130	130	130	130	130	130	116	104	95						
800	130	130	130	130	130	114	101	91							
700	130	130	130	130	111	98	87								
600	430	500	550	600	700	800	900	1000	1100	1200	1300	1400	1500	1600	1700

Table of maximum glass thickness [mm]
(weight up to 170 kg)

2500	43	39	47	40	35	31	28	26	24	22	20	19	18	17	
2400	45	41	49	42	37	33	30	27	25	23	21	20	18	17	
2300	47	43	50	44	39	34	31	28	26	24	22	21	19	18	
2200	50	45	50	46	40	36	32	29	27	25	23	22	20	19	
2100	50	47	50	49	43	38	34	31	28	26	24	23	21	19	
2000	50	50	50	50	45	40	36	33	30	28	26	24	22	19	
1900	50	50	50	50	47	42	38	34	31	29	27	25	22	19	
1800	50	50	50	50	50	44	40	36	33	31	29	25	22	19	
1700	50	50	50	50	50	47	43	39	35	33	29	25	22	19	
1600	50	50	50	50	50	50	45	41	38	33	29	25	22	19	
1500	50	50	50	50	50	50	49	44	39	33	29	25	22	19	
1400	50	50	50	50	50	50	50	47	39	33	29	25	22	19	
1300	50	50	50	50	50	50	50	47	39	33	29	25	22		
1200	50	50	50	50	50	50	50	47	39	33	29	25			
1100	50	50	50	50	50	50	50	47	39	33	29				
1000	50	50	50	50	50	50	50	47	39	33					
900	50	50	50	50	50	50	50	47	39						
800	50	50	50	50	50	50	50	47							
700	50	50	50	50	50	50	50								
600	430	500	550	600	700	800	900	1000	1100	1200	1300	1400	1500	1600	1700

Table of maximum load capacity [kg]
(weight up to 170 kg)

2500	130	130	170	170	170	170	170	170	170	170	170	170	170	170	
2400	130	130	170	170	170	170	170	170	170	170	170	170	170	170	
2300	130	130	170	170	170	170	170	170	170	170	170	170	170	170	
2200	130	130	170	170	170	170	170	170	170	170	170	170	170	170	
2100	130	130	170	170	170	170	170	170	170	170	170	170	170	163	
2000	130	130	170	170	170	170	170	170	170	170	170	170	165	154	
1900	130	130	170	170	170	170	170	170	170	170	170	167	156	146	
1800	130	130	170	170	170	170	170	170	170	170	170	158	147	138	
1700	130	130	170	170	170	170	170	170	170	170	160	149	139	130	
1600	130	130	170	170	170	170	170	170	170	163	150	139	130	122	
1500	130	130	170	170	170	170	170	165	152	140	130	121	114	114	
1400	130	130	170	170	170	170	170	169	154	141	130	121	113	106	
1300	130	130	170	170	170	170	170	156	142	130	120	111	104		
1200	130	130	170	170	170	170	159	143	130	119	110	102			
1100	130	130	170	170	170	163	144	130	118	108	100				
1000	130	130	170	170	167	146	130	117	106	98					
900	130	130	170	170	149	130	116	104	95						
800	130	130	165	152	130	114	101	91							
700	130	130	142	130	111	98	87								
600	430	500	550	600	700	800	900	1000	1100	1200	1300	1400	1500	1600	1700

Futura 3D 170 HP Invisible traditional

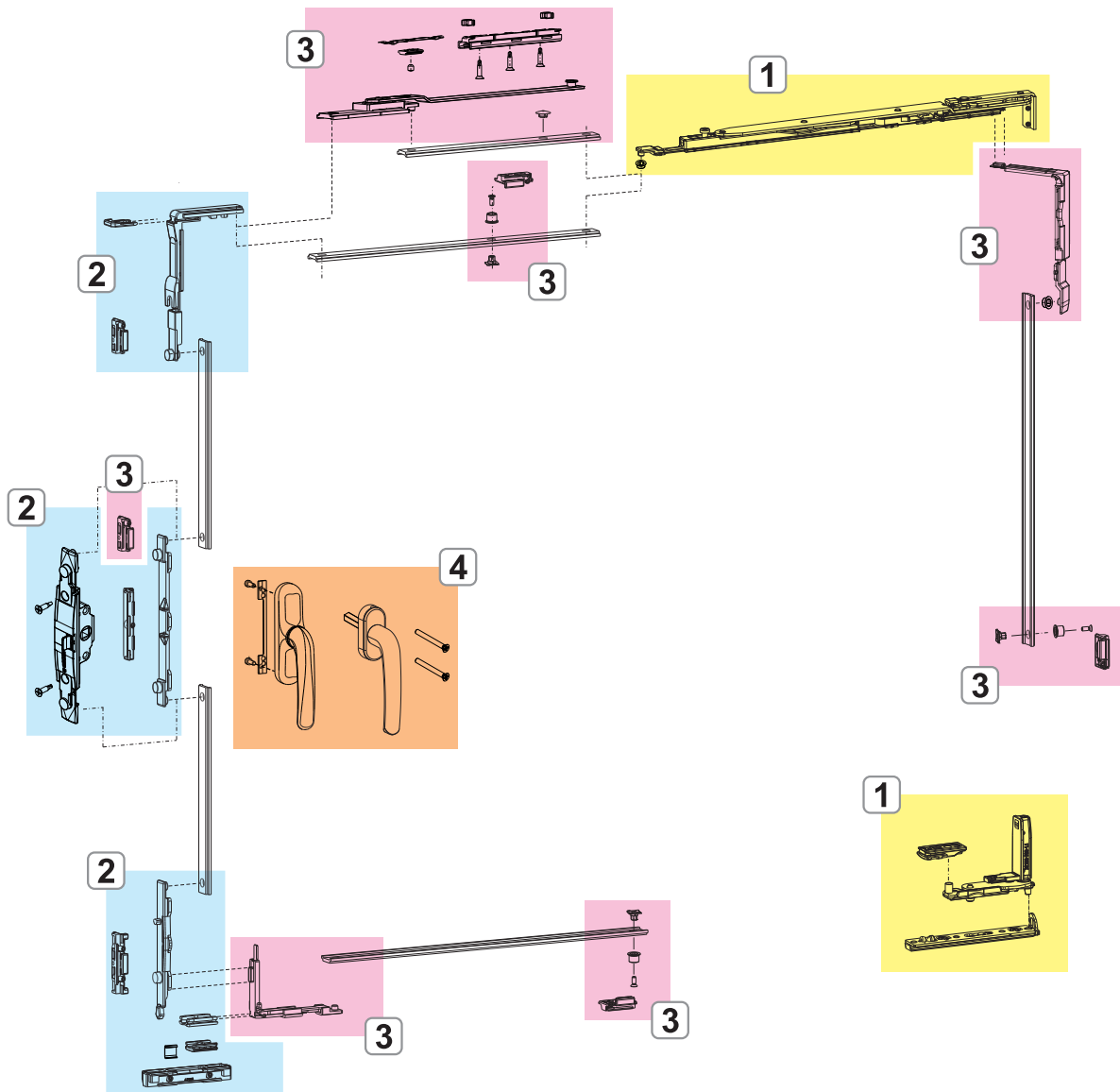

1. FUTURA 3D 170 HP INVISIBLE HINGES AND ARMS
2. FUTURA 3D 170 HP INVISIBLE FASTENING MECHANISMS
3. FUTURA 3D 170 HP INVISIBLE ADDITIONAL FASTENING MECHANISMS AND ACCESSORIES
4. CREMONES AND WINDOW HANDLES

FUTURA 3D
170 HP Invisible lgc

Futura 3D 170 HP Invisible logica

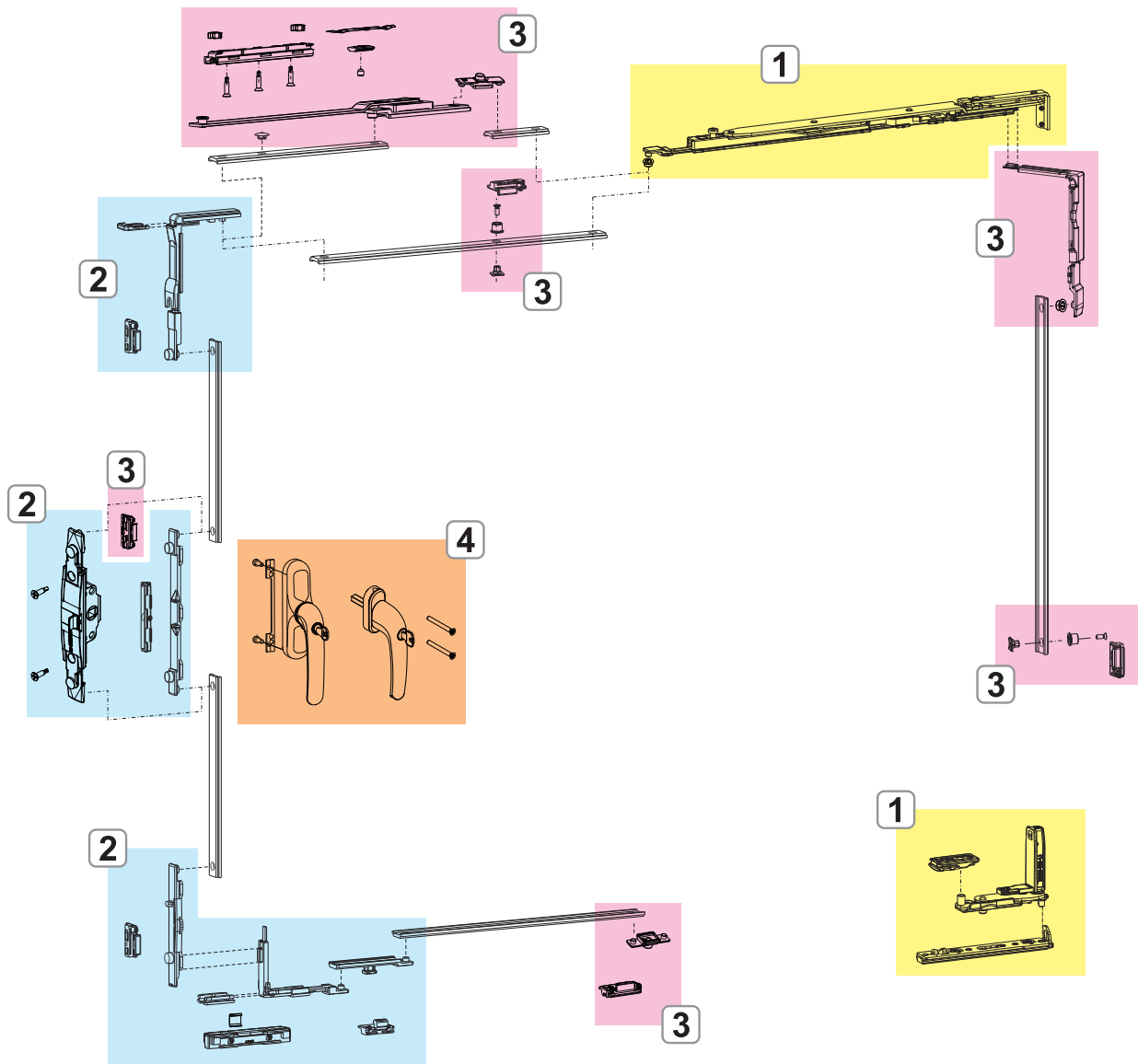

- 1. FUTURA 3D 170 HP INVISIBLE HINGES AND ARMS
- 2. FUTURA 3D 170 HP INVISIBLE FASTENING MECHANISMS
- 3. FUTURA 3D 170 HP INVISIBLE ADDITIONAL FASTENING MECHANISMS AND ACCESSORIES
- 4. CREMONES AND WINDOW HANDLES

FUTURA 3D 170 HP INVISIBLE HINGES AND ARMS

Functions

Hinges (upper and lower) and arm kit, completely pre-assembled and ready to be installed on the profile.

Materials

Body of hinges and arms in stainless steel and zamak.

Rod, connecting bracket, pins, screws and grub screws in stainless steel.

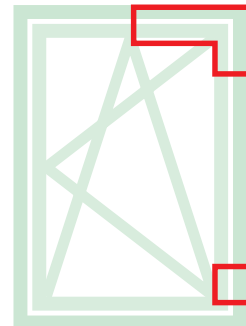

Online data sheet



T/T Futura 170 Invisible Kit (420÷640) - LX

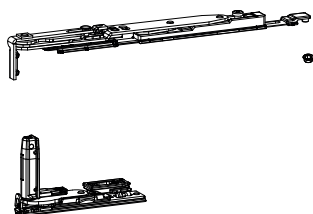

T/T Futura 170 Invisible Kit (420÷640) - RX

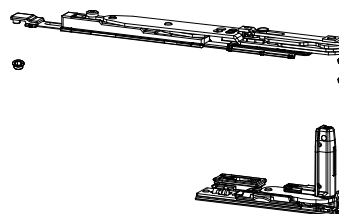

T/T Futura 170 Invisible Kit (641÷1700) - LX

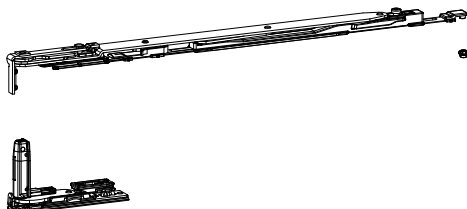

T/T Futura 170 Invisible Kit (641÷1700) - RX

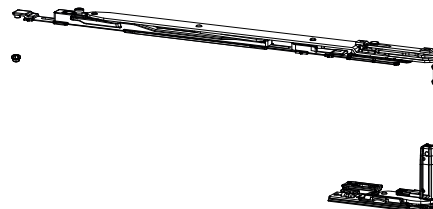

T/T Futura 170 Invisible Kit LGC (420÷640) - LX

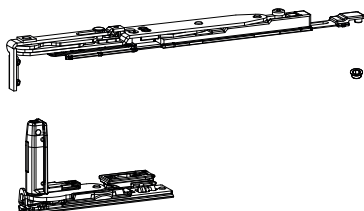

T/T Futura 170 Invisible Kit LGC (420÷640) - RX

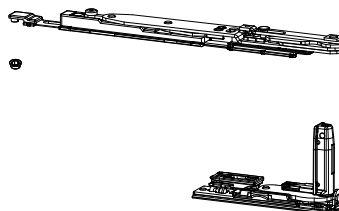

T/T Futura 170 Invisible Kit LGC (641÷1700) - LX

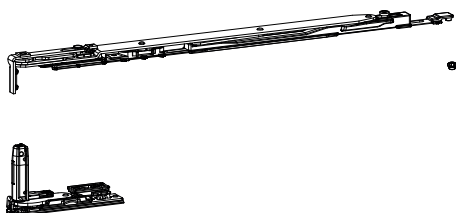

T/T Futura 170 Invisible Kit LGC (641÷1700) - RX

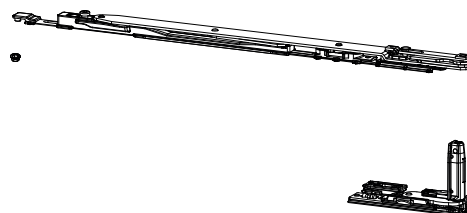

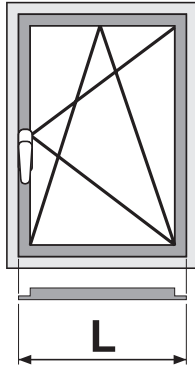

Item code	Description	PROFILE CROSS - SECTION	Range (mm)	Version	Hand	Base Raw	Anodised Elox	Painted	Trend/Gold Brass	Pieces per pack
042061	T/T FUTURA 170 INVISIBLE KIT	C001	W 430 ÷ 640	-	RX	X				5
042062	T/T FUTURA 170 INVISIBLE KIT	C001	W 430 ÷ 640	-	LX	X				5
042071	T/T FUTURA 170 INVISIBLE KIT	C001	W 641 ÷ 1700	-	RX	X				5
042072	T/T FUTURA 170 INVISIBLE KIT	C001	W 641 ÷ 1700	-	LX	X				5
042091	AR FUTURA 170 INVISIBLE LGC KIT	C001	W 641 ÷ 1700	Logica	RX	X				5
042092	AR FUTURA 170 INVISIBLE LGC KIT	C001	W 641 ÷ 1700	Logica	LX	X				5

FUTURA 3D 170 HP INVISIBLE FASTENING MECHANISMS

Functions

Tilt-and-turn window fastening mechanisms for cremone or window handle, available in Base and Logica versions.

Materials

Drive, drive rod, mechanism bolt tip and strikers in zamak with GS Silver Plus finish (up to 500 h of corrosion resistance).

Screws and grub screws in stainless steel.

Polyamide raiser.

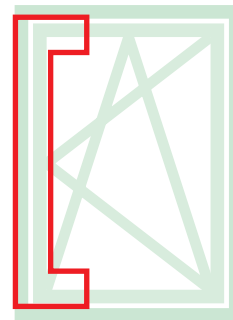

Online data sheet

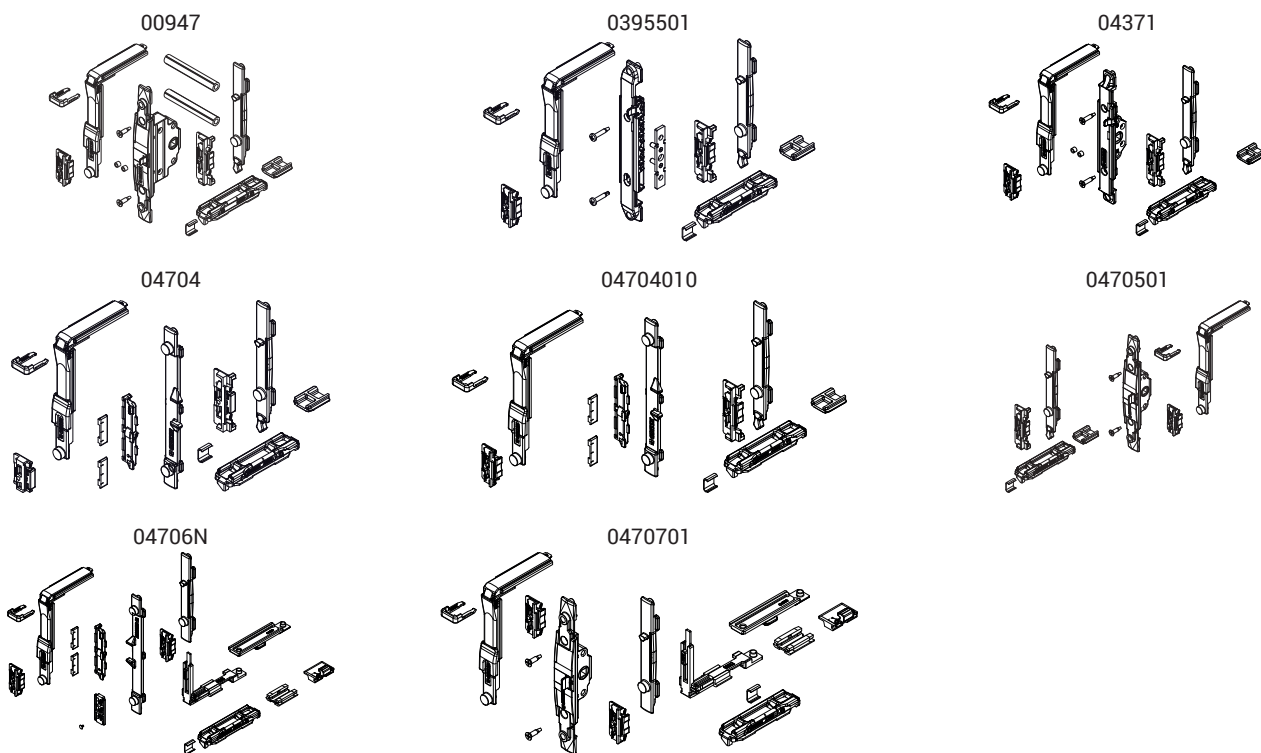

Item code	Description	PROFILE CROSS - SECTION	Mechanism	Version	Base Raw	Anodised Elox	Painted	Trend/Gold Brass	Pieces per pack
00947	T/T M 180 MOVEMENT FASTENING MECHANISM	C001-C002-C003-C005-C006-C013-C014-C015-C017	Window handle	-	X				10
0395501	T/T FASTENING MECHANISM	C001-C002-C003-C005-C006-C013-C014-C015-C017	NP SUPRA	-	X				10
04371	FASTENING MECHANISM T/T MOVEMENT M 180	C001-C002-C004-C005-C006-C013-C014-C015-C016-C017	Window handle	-	X				10
04704	T/T FASTENING MECHANISM	C001-C002-C004-C005-C006-C013-C014-C015-C016-C017	Cremona	-	X				10
04704010	T/T FASTENING MECHANISM	C003	Cremona	-	X				10
0470501	T/T M 180 FASTENING MECHANISM	C001-C002-C004-C005-C006-C013-C014-C015-C016-C017	Window handle - SUPRA 7	-	X				10
04706N	T/T LOGICA FASTENING MECHANISM	C001-C002-C004-C005-C006-C013-C014-C015-C016-C017	Cremona	Logica	X				10
0470701	T/T M 180 LOGICA FASTENING MECHANISM	C001-C002-C004-C005-C006-C013-C014-C015-C016-C017	Window handle	Logica	X				10

FUTURA 3D 170 HP INVISIBLE ADDITIONAL FASTENING MECHANISMS AND ACCESSORIES

Functions

The FUTURA 3D 170 HP Invisible tilt-and-turn window has a basic load capacity of 130 kg, to obtain a maximum load capacity of 170 kg you need to use the reinforcement set. This product is designed for sash profiles with a smooth channel. In the case of profiles with a machined channel, shims of 1.5 mm and 2 mm must be used.

The additional fasteners make it possible to add further fastening elements that either increase the dimensions of the casement or that can be used when locking points are needed on the cross beams or hinge-side upright.

On the basis of the dimensions of the casement, additional fasteners (for H>1200 mm and W>1000 mm) and the additional arm (which is mandatory for W>1000 mm) are to be used in combination with this mechanism.

The micro-ventilation device can be fitted at any time, even after the window is installed. When activated with the cremone at 180° there is micro-ventilation (precision sash opening), when it is not activated, with the cremone at 180° there is tilt-and-turn opening.

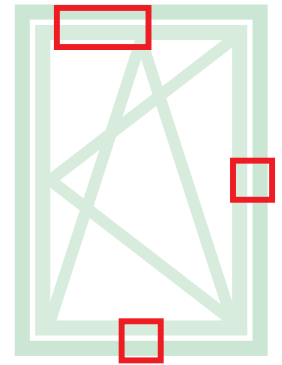

Online data sheet



03520

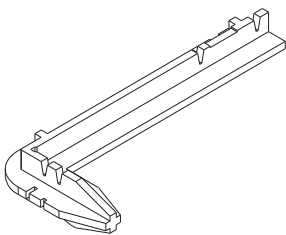

04012

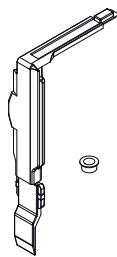

04014K

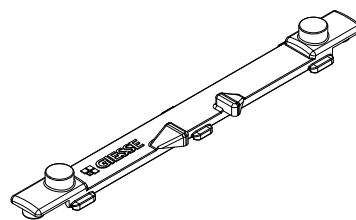

04019K

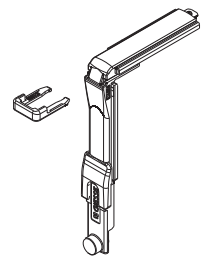

04020K

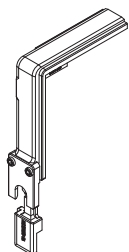

04024K

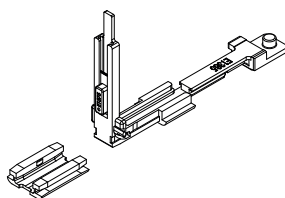

04026K

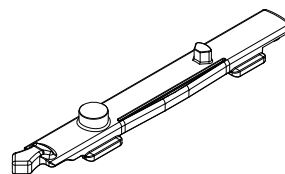

04301K

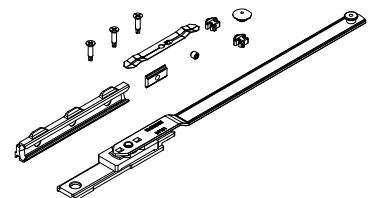

04311

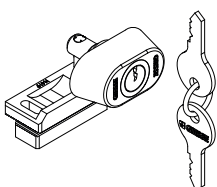

04407

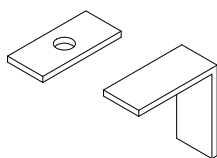

04409

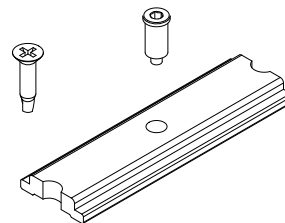

04411

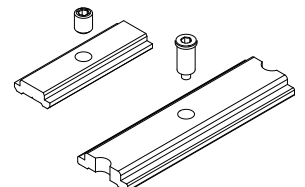

04770K

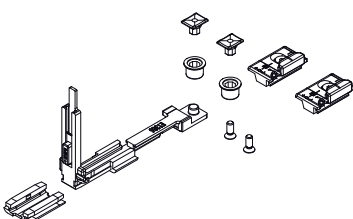

04777K

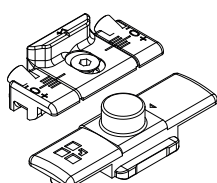

FUTURA 3D 170 HP INVISIBLE

Micro-ventilation

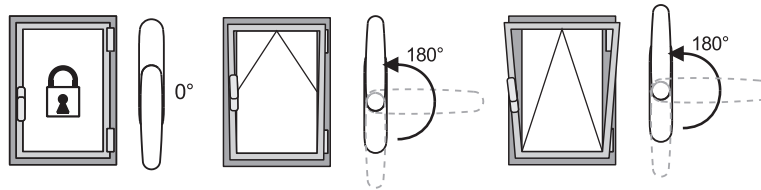

Item code	Description	PROFILE CROSS - SECTION	Range (mm)	Version	Base Raw	Anodised Elox	Painted	Trend/Gold Brass	Pieces per pack
03520	TEMPLATE FOR AR FUTURA	C001-C002-C003-C004-C005-C006-C011-C012-C013-C014-C015-C016-C017	-	-	X				20
04012	CORNER DRIVE FOR FUTURA 170HP INVISIBLE	C001-C002-C003	H > 1200	-	X				10
04014K	FUTURA T/T DRIVE ROD	C001-C002-C003-C004-C005-C006-C013-C014-C015-C016-C017	-	-	X				10
04019K	CORNER DRIVE GROOVE 15/20 FUTURA	C001-C002-C003-C004-C005-C006-C009-C010-C011-C012-C013-C014-C015-C016-C017	-	-	X				10
04020K	FUTURA CORNER DRIVE	C001-C002-C003-C004-C005-C006-C009-C010-C011-C012-C013-C014-C015-C016-C017-P001-P002-P003-P004-P005-P006-P007-P008-P009-P010	-	-	X				50
04024K	CORNER DRIVE FOR FUTURA BURGLAR-PROOF FUNCTION	C001-C002-C003-C004-C005-C006-C013-C014-C015-C016-C017	-	-	X				10
04026K	FUTURA T/T BOLT TIP	C001-C002-C003-C005-C006-C013-C014-C015-C017	-	-	X				10
04301K	T/T FUTURA ADDITIONAL ARM	C001-C002-C003-C004-C005-C006	W > 1000	-	X				5
04311	SASH OPENING BLOCK LOCK	C001-C002-C003-C004-C005-C006-C007-C013-C014-C015-C016-C017	-	-	X				10
04407	SHIMS FOR FUTURA 3D 170 HP INVISIBLE	C001-C002-C003	2	-	X				10
04409	REINFORCEMENT FOR FUTURA 170 HP INVISIBLE	C001-C002	130 -> 170 Kg	-	X				10
04411	REINFORCEMENT FOR FUTURA 170 HP INVISIBLE	C003	130 -> 170 Kg	-	X				10
04770K	FUTURA ADDITIONAL FASTENING MECHANISM	C001-C002-C003-C004-C005-C006-C013-C014-C015-C016-C017	H > 1200 L > 1000	-	X				10
04777K	FUTURA ADDITIONAL FASTENING MECHANISM	C001-C002-C003-C004-C005-C006-C013-C014-C015-C016-C017	H > 1200 L > 1000	Logica	X				50

FUTURA 3D 170 HP INVISIBLE SECONDARY SASH

Functions

FUTURA 3D 170 HP Invisible features specific hinges for the secondary sash, with the same retractable styling line and the same adjustments.

Materials

Body of hinges in stainless steel and zamak.
Pins, screws and grub screws in stainless steel.

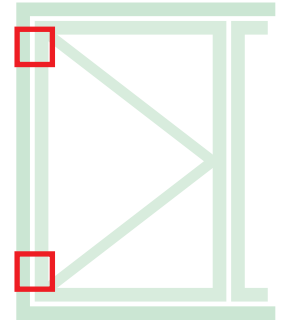

Online data sheet



044001

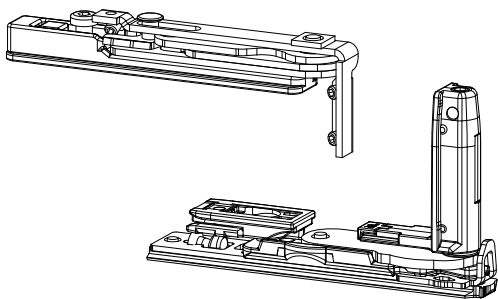

044002

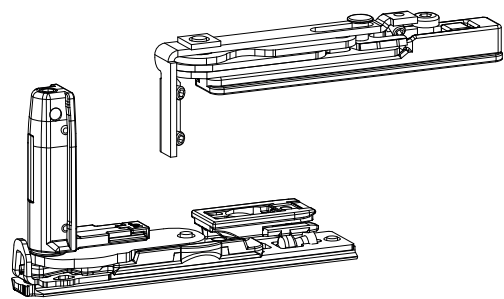

Item code	Description	PROFILE CROSS - SECTION	Hand	Base Raw	Anodised Elox	Painted	Trend/Gold Brass	Pieces per pack
044001	INVISIBLE SECONDARY SASH HINGE KIT	C001	RX	X				10
044002	INVISIBLE SECONDARY SASH HINGE KIT	C001	LX	X				10

CONFIGURATION EXAMPLES

FUTURA 3D 170 HP INVISIBLE

Basic configuration with Cremone

MAIN SASH			
Sash width	430 ÷ 640	641 ÷ 1000	1001 ÷ 1700
Hinges and arm	04206	04207	04207
Mechanism	04704 - 04704010	04704 - 04704010	04704 - 04704010
Additional arm	-	-	04301K
Cremone	01039 - 01090K	01039 - 01090K	01039 - 01090K
SECONDARY SASH			
Hinges	04400	04400	04400
Adjustable Bolt	02168K	02168K	02168K
Single striker	01348	01348	01348

Basic configuration with window handle

MAIN SASH			
Sash width	430 ÷ 640	641 ÷ 1000	1001 ÷ 1700
Hinges and arm	04206	04207	04207
Mechanism	0470501	0470501	0470501
Additional arm	-	-	04301K
Window handle	02476 - 02415 - 00997	02476 - 02415 - 00997	02476 - 02415 - 00997
SECONDARY SASH			
Hinges	04400	04400	04400
Adjustable Bolt	02168K	02168K	02168K
Single striker	01348	01348	01348

Micro configuration with Cremone

MAIN SASH			
Sash width	430 ÷ 640	641 ÷ 1000	1001 ÷ 1700
Hinges and arm	04206	04207	04207
Mechanism	04704 - 04704010	04704 - 04704010	04704 - 04704010
Micro-ventilation	02234K	02234K	02234K
Additional arm	-	-	04301K
Cremone	01039 - 01090K	01039 - 01090K	01039 - 01090K
SECONDARY SASH			
Hinges	04400	04400	04400
Adjustable Bolt	02168K	02168K	02168K
Single striker	01348	01348	01348

Micro configuration with window handle

MAIN SASH			
Sash width	430 ÷ 640	641 ÷ 1000	1001 ÷ 1700
Hinges and arm	04206	04207	04207
Mechanism	0470501	0470501	0470501
Micro-ventilation	02234K	02234K	02234K
Additional arm	-	-	04301K
Window handle	02476 - 02415 - 00997	02476 - 02415 - 00997	02476 - 02415 - 00997
SECONDARY SASH			
Hinges	04400	04400	04400
Adjustable Bolt	02168K	02168K	02168K
Single striker	01348	01348	01348

Micro configuration with NP Supra

MAIN SASH			
Sash width	430 ÷ 640	641 ÷ 1000	1001 ÷ 1700
Hinges and arm	04206	04207	04207
Mechanism	0395501	0395501	0395501
Micro-ventilation	02234K	02234K	02234K
Additional arm	-	-	04301K
NP Supra	03962 - 03963	03962 - 03963	03962 - 03963
SECONDARY SASH			
Hinges	04400	04400	04400
Adjustable Bolt	02168K	02168K	02168K
Single striker	01348	01348	01348

Logica configuration with Cremone

MAIN SASH			
Sash width	430 ÷ 640	641 ÷ 1000	1001 ÷ 1700
Hinges and arm	04208	04209	04209
Mechanism	04706N - 04706010N	04706N - 04706010N	04706N - 04706010N
Additional arm	-	-	04301K
Cremone	01192 - 01193	01192 - 01193	01192 - 01193
SECONDARY SASH			
Hinges	04400	04400	04400
Adjustable Bolt	02168K	02168K	02168K
Single striker	01348	01348	01348

Logica configuration with window handle

MAIN SASH			
Sash width	430 ÷ 640	641 ÷ 1000	1001 ÷ 1700
Hinges and arm	04208	04209	04209
Mechanism	0470701	0470701	0470701
Additional arm	-	-	04301K
Window handle	02486	02486	02486
SECONDARY SASH			
Hinges	04400	04400	04400
Adjustable Bolt	02168K	02168K	02168K
Single striker	01348	01348	01348

Logica configuration with NP Supra

MAIN SASH			
Sash width	430 ÷ 640	641 ÷ 1000	1001 ÷ 1700
Hinges and arm	04208	04209	04209
Mechanism	0395501	0395501	0395501
Additional arm	-	-	04301K
NP Supra	03962 - 03963	03962 - 03963	03962 - 03963
SECONDARY SASH			
Hinges	04400	04400	04400
Adjustable Bolt	02168K	02168K	02168K
Single striker	01348	01348	01348

FUTURA 3D 80 FLUSH



Functions

Complete system for the construction of tilt-and-turn windows with load capacities of up to 90 kg. Available in the standard, logic and microventilation versions.

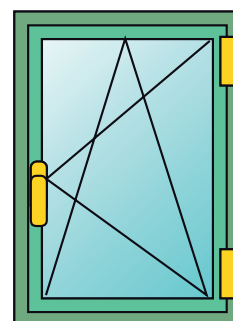

Technical Features

Making a FUTURA 3D 80 Flush tilt-and-turn window mechanism requires:

- Hinge kit
- Set of fastening mechanisms for Cremones and window handles
- Arms, available in three versions (standard, micro-ventilation and logic)
- Cremona or window handle (available in different models to choose from in the specific catalogue section)

Adjustments

The FUTURA 3D tilt-and-turn window enables micrometric adjustment in every direction, ideal after installing the casement.

Micro-ventilation

Microventilation enables having simultaneously both the tilt-and-turn position and micro-ventilation (precision opening of the sash) on the casement. Available both as standard and with an additional device.

Logica

The logical operation consists in first tilt-and-turn opening (with the cremona at 90°) and secondly side-hung opening (with the cremona at 180°). Its use is particularly recommended in public buildings (schools, hospitals, etc.) in combination with a cremona with a key in order to have only tilt-and-turn window opening for safety reasons and to allow full opening only for staff with the key.

Logica mechanism operation

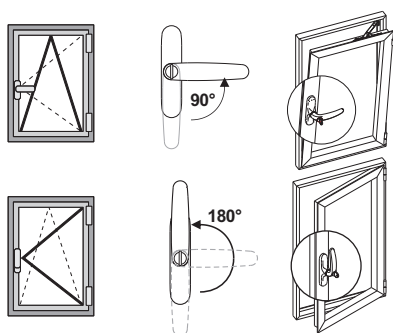

Standard microventilation

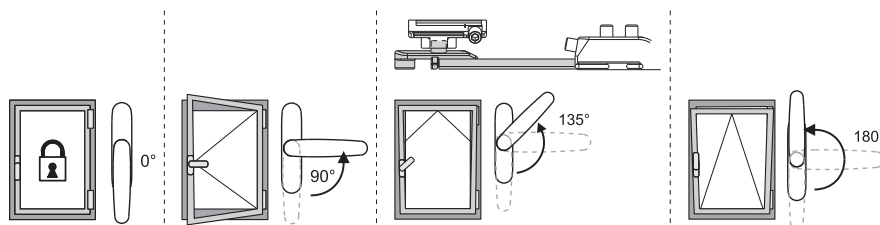

ADJUSTMENTS [mm]

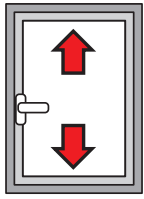

Height:
+1.5 / -0.5

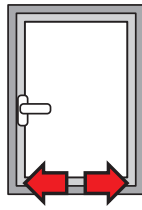

Side:
±1

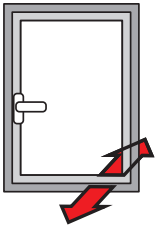

Bottom hinge compression:
±0.3

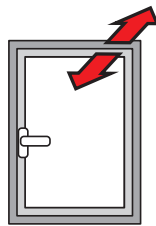

Top hinge compression:
±1.5

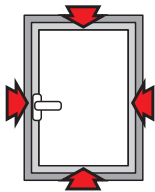

Striker compression:
±1.8

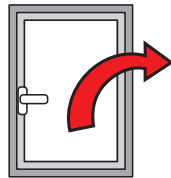

Sash fall:
+3.5 / -1.5

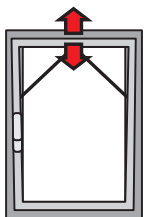

Micro-ventilation:
+3.6 / -1.8

Table of maximum glass thickness [mm]

2500	28	24	20	18	16	14	13	12	11	10	9	9	8	
2400	29	25	21	18	16	15	13	12	11	11	10	9	9	
2300	31	26	22	19	17	15	14	13	12	11	10	10	9	
2200	32	27	23	20	18	16	15	13	12	11	11	10	9	
2100	34	28	24	21	19	17	15	14	13	12	11	11	10	
2000	35	29	25	22	20	18	16	15	14	13	12	11	10	
1900	37	31	27	23	21	19	17	15	14	13	12	12	11	
1800	39	33	28	25	22	20	18	16	15	14	13	12	11	
1700	42	35	30	26	23	21	19	17	16	15	14	13	11	
1600	42	37	32	28	25	22	20	18	17	16	14	13	11	
1500	42	39	34	29	26	24	21	20	18	16	14	13	11	
1400	42	42	36	32	28	25	23	21	19	16	14	13	11	
1300	42	42	39	34	30	27	25	22	19	16	14	13		
1200	42	42	42	37	33	29	27	22	19	16	14			
1100	42	42	42	40	36	32	27	22	19	16				
1000	42	42	42	42	39	32	27	22	19					
900	42	42	42	42	40	32	27	22						
800	42	42	42	42	40	32	27							
700	42	42	42	42	40	32								
600														
	390	500	600	700	800	900	1000	1100	1200	1300	1400	1500	1600	1700

Table of maximum load capacity [kg]

2500	90	90	90	90	90	90	90	90	90	90	90	90	90	90
2400	90	90	90	90	90	90	90	90	90	90	90	90	90	90
2300	90	90	90	90	90	90	90	90	90	90	90	90	90	90
2200	90	90	90	90	90	90	90	90	90	90	90	90	90	90
2100	90	90	90	90	90	90	90	90	90	90	90	90	90	90
2000	90	90	90	90	90	90	90	90	90	90	90	90	90	90
1900	90	90	90	90	90	90	90	90	90	90	90	90	90	90
1800	90	90	90	90	90	90	90	90	90	90	90	90	90	87
1700	90	90	90	90	90	90	90	90	90	90	90	90	87	82
1600	90	90	90	90	90	90	90	90	90	90	88	82	77	77
1500	90	90	90	90	90	90	90	90	90	88	82	77	72	68
1400	90	90	90	90	90	90	90	90	89	82	77	72	67	
1300	90	90	90	90	90	90	90	89	82	76	71	67		
1200	90	90	90	90	90	90	90	82	76	71	66			
1100	90	90	90	90	90	90	82	75	70	65				
1000	90	90	90	90	90	82	75	69	63					
900	90	90	90	90	82	74	67	62						
800	90	90	90	90	82	73	66	60						
700	90	90	82	72	64	58								
600														
	390	500	600	700	800	900	1000	1100	1200	1300	1400	1500	1600	1700

FUTURA 3D
80

FUTURA 3D
80 micro

Futura 3D 80 traditional

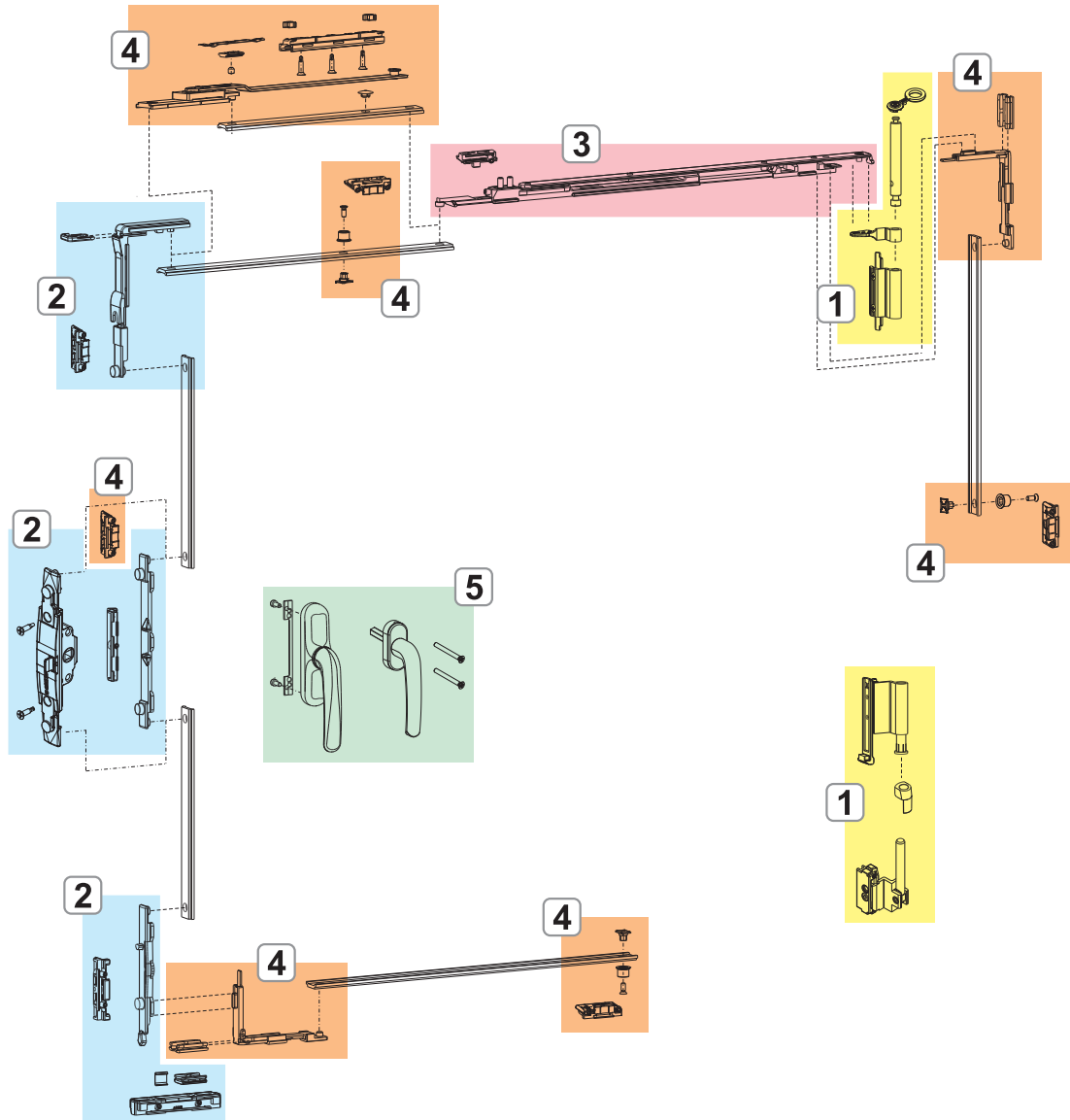

1. FLUSH FUTURA 3D 80 HINGES
2. FUTURA 3D 80 FLUSH FASTENING MECHANISMS
3. FLUSH FUTURA 3D 80 ARMS
4. FLUSH FUTURA 3D 80 ADDITIONAL FASTENING MECHANISMS AND ACCESSORIES
5. CREMONES AND WINDOW HANDLES



Futura 3D 80 logica

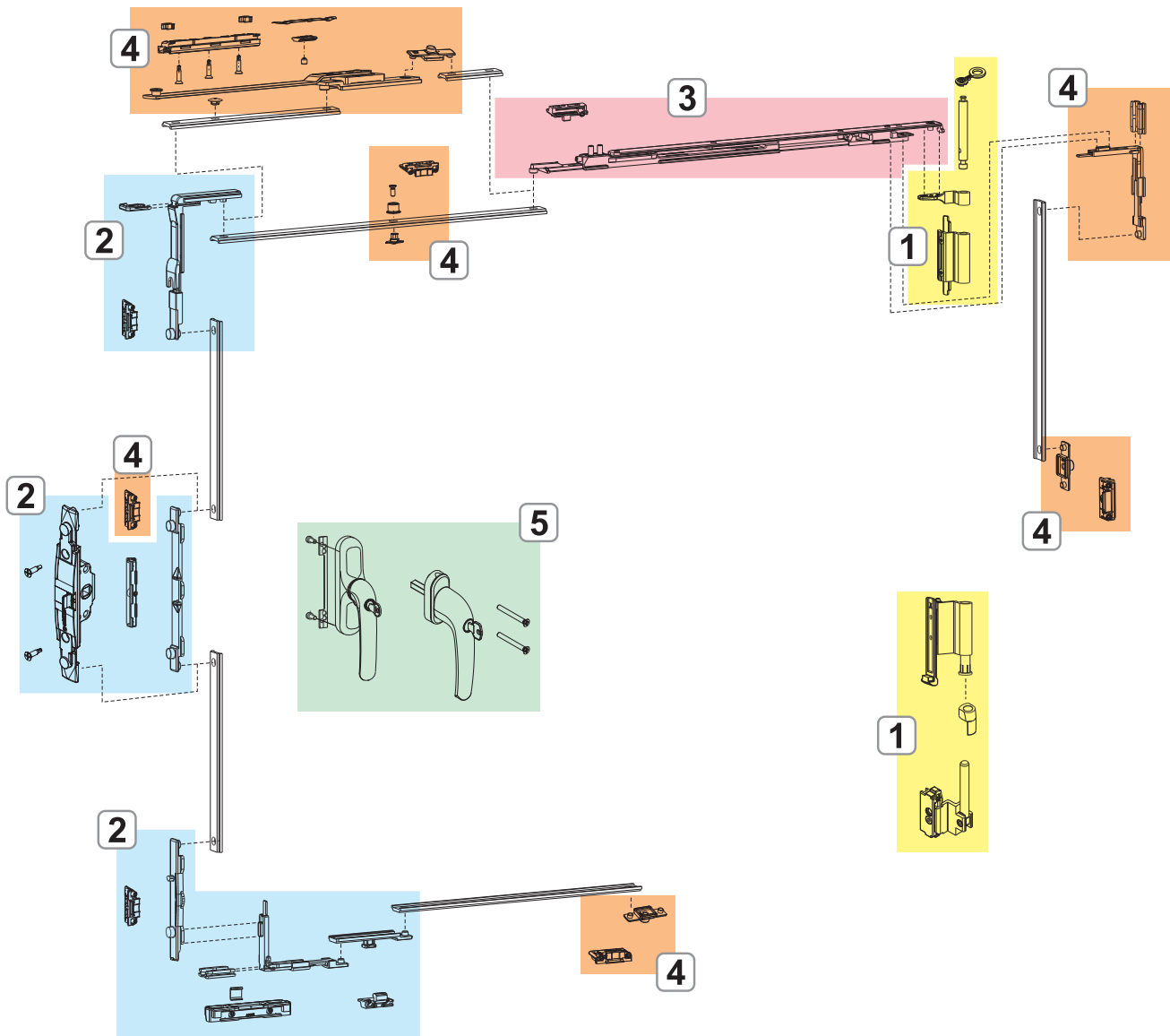

1. FLUSH FUTURA 3D 80 HINGES
2. FUTURA 3D 80 FLUSH FASTENING MECHANISMS
3. FLUSH FUTURA 3D 80 ARMS
4. FLUSH FUTURA 3D 80 ADDITIONAL FASTENING MECHANISMS AND ACCESSORIES
5. CREMONES AND WINDOW HANDLES

FLUSH FUTURA 3D 80 HINGES

Functions

Hinge set (upper and lower), completely pre-assembled and ready to be installed on the profile.

Materials

Body of hinges in extruded aluminium, stainless steel and brass.

Supports in zamak with GS Silver Plus finish (up to 500 hr corrosion resistance).

Pins, screws and grub screws in stainless steel.

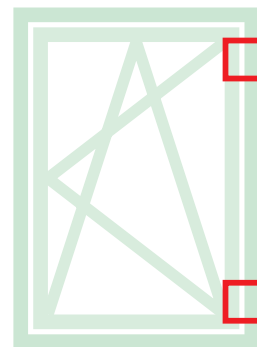

Online data sheet



04718

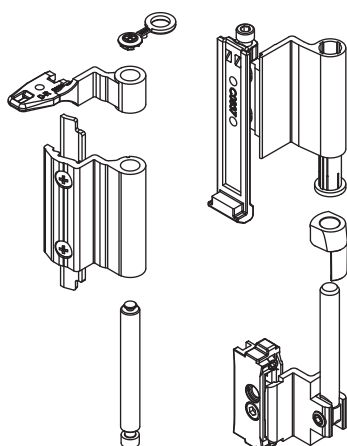

Item code	Description	PROFILE CROSS - SECTION	Base Raw	Anodised Elox	Painted	Trend/Gold Brass	Pieces per pack
04718	HINGE T/T FUTURA 3D	C013-C014-C015-C016-C017	X		X	X	10

FUTURA 3D 80 FLUSH FASTENING MECHANISMS

Functions

Tilt-and-turn window fastening mechanisms for cremone or window handle, available in Base and Logica versions.

Materials

Drive, drive rod, mechanism bolt tip and strikers in zamak with GS Silver Plus finish (up to 500 h of corrosion resistance).

Screws and grub screws in stainless steel.

Polyamide raiser.

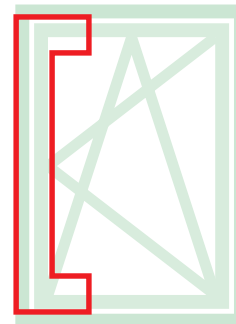

Online data sheet



00947

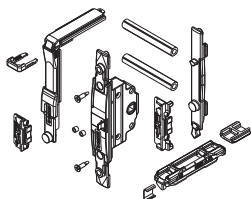

0395501

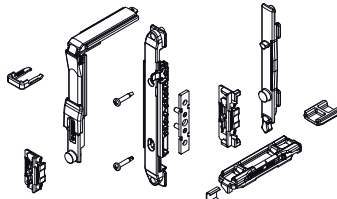

04371

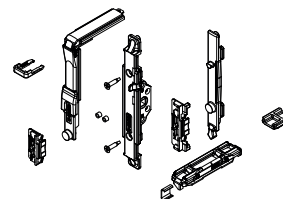

04704

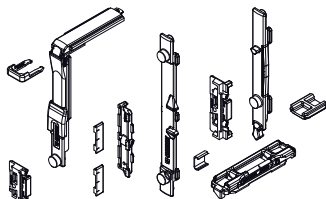

0470501

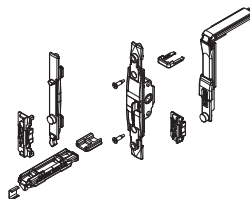

04706N

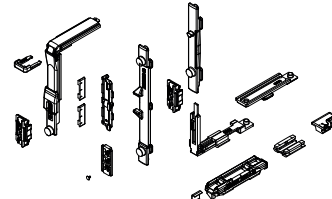

0470701

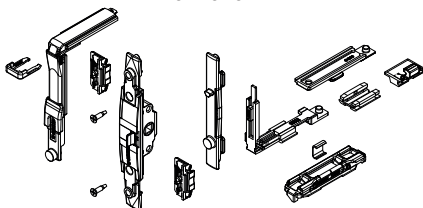

Item code	Description	PROFILE CROSS - SECTION	Mechanism	Version	Base Raw	Anodised Elox	Painted	Trend/Gold Brass	Pieces per pack
00947	T/T M 180 MOVEMENT FASTENING MECHANISM	C001-C002-C003-C005-C006-C013-C014-C015-C017	Window handle	-	X				10
0395501	T/T FASTENING MECHANISM	C001-C002-C003-C005-C006-C013-C014-C015-C017	NP SUPRA	-	X				10
04371	FASTENING MECHANISM T/T MOVEMENT M 180	C001-C002-C004-C005-C006-C013-C014-C015-C016-C017	Window handle - SUPRA 7	-	X				10
04704	T/T FASTENING MECHANISM	C001-C002-C003-C005-C006-C013-C014-C015-C016-C017	Cremone	-	X				10
0470501	T/T M 180 FASTENING MECHANISM	C001-C002-C004-C005-C006-C013-C014-C015-C016-C017	Window handle - SUPRA 7	-	X				10
04706N	T/T LOGICA FASTENING MECHANISM	C001-C002-C003-C005-C006-C013-C014-C015-C016-C017	Cremone	Logica	X				10
0470701	T/T M 180 LOGICA FASTENING MECHANISM	C001-C002-C004-C005-C006-C013-C014-C015-C016-C017	Window handle	Logica	X				10

FLUSH FUTURA 3D 80 ARMS

Functions

They enable tilt-and-turn opening in conjunction with the mechanisms and are available in three versions (standard, microventilation and logic).

Materials

Body, fixing block and slider in zamak with GS Silver Plus finish (up to 500 h of corrosion resistance). Rod, connecting bracket, grub screws and screws in stainless steel. Stop disk in polyamide.

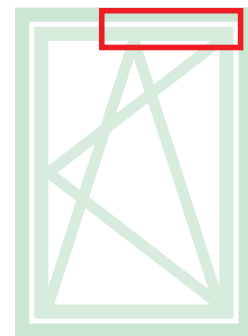

Online data sheet



04202

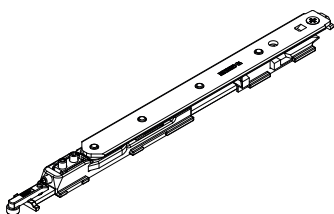

04203

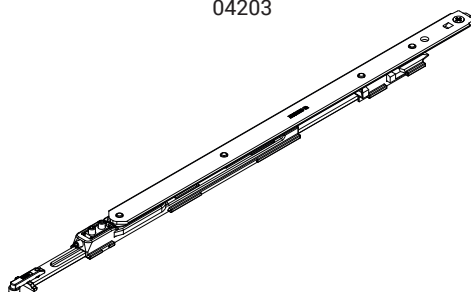

04284

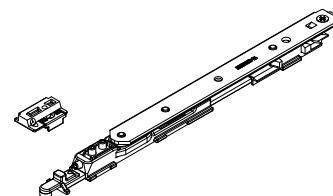

04285

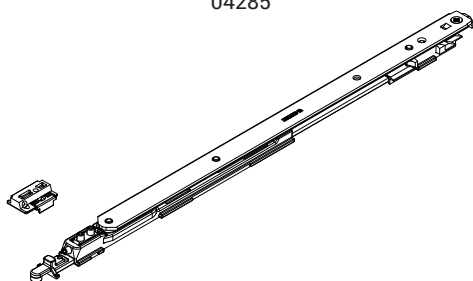

04344

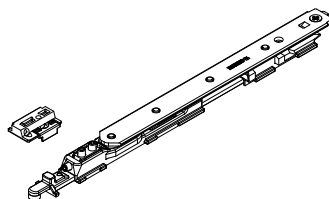

04345

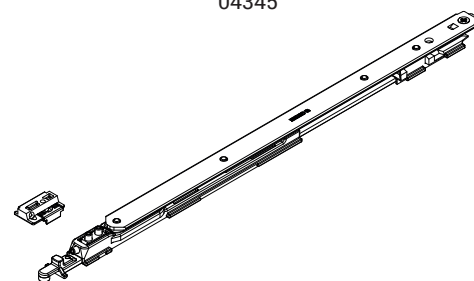

Item code	Description	PROFILE CROSS - SECTION	Range (mm)	Version	A (mm)	Base Raw	Anodised Elox	Painted	Trend/Gold Brass	Pieces per pack
04202	ARM TYPE 1 T/T FUTURA LOGICA 130	C001-C002-C003-C005-C006-C013-C014-C015-C016-C017	W 390 ÷ 700	Logica	120					10
04203	ARM TYPE 2 T/T FUTURA LOGICA 130	C001-C002-C003-C005-C006-C013-C014-C015-C016-C017	W 701 ÷ 1800	Logica	175					10
04284	ARM T1 130 WITH MICROVENTILATION	C001-C002-C003-C015-C016-C017	W 410 ÷ 700	Micro	120					10
04285	ARM T2 130 WITH MICROVENTILATION	C001-C002-C003-C015-C016-C017	W 701 ÷ 1800	Micro	175					10
04344	ARM T1 130 MICROVENTILATION LOGIC	C001-C002-C003-C015-C016-C017	W 410 ÷ 700	Logica Micro	120					10
04345	ARM T2 130 MICROVENTILATION LOGIC	C001-C002-C003-C015-C016-C017	W 701 ÷ 1800	Logica Micro	175					10

FLUSH FUTURA 3D 80 ADDITIONAL FASTENING MECHANISMS AND ACCESSORIES

Functions

The additional fasteners make it possible to add further fastening elements that either increase the dimensions of the casement or that can be used when locking points are needed on the cross beams or hinge-side upright.

On the basis of the dimensions of the casement, additional fasteners (for $H > 1200$ mm and $W > 1000$ mm) and the additional arm (which is mandatory for $W > 1000$ mm) are to be used in combination with this mechanism

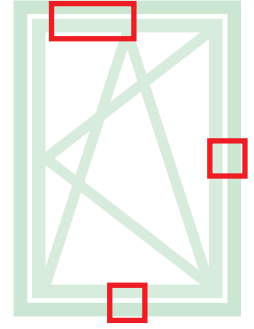

Online data sheet



01299

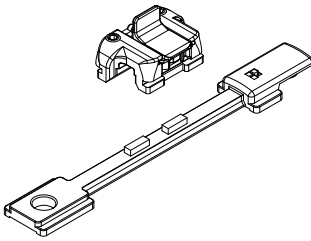

03520

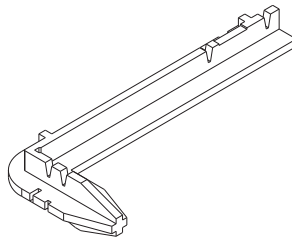

04014K

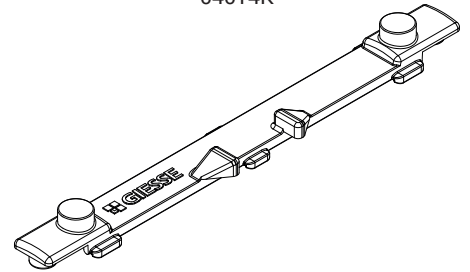

04019K

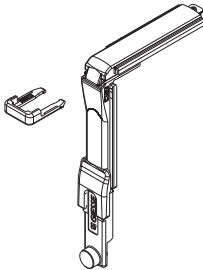

04020K

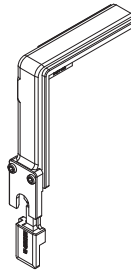

04024K

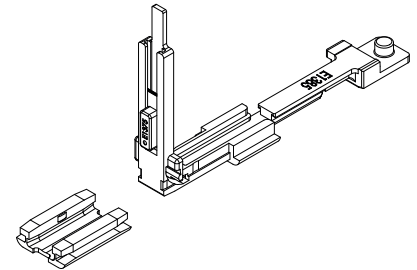

04026K

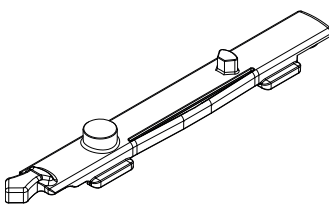

04301K

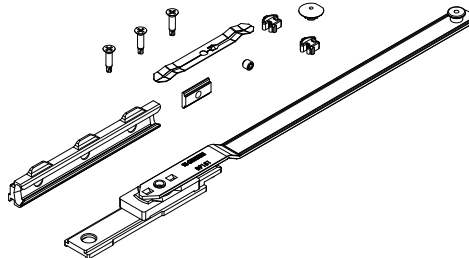

04311

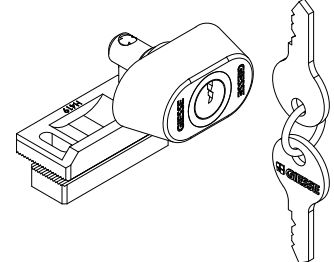

04770K

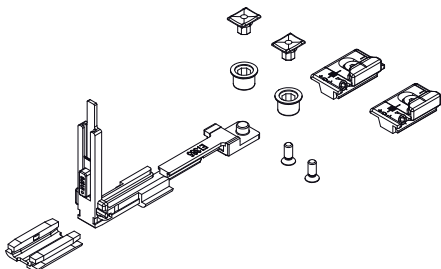

04777K

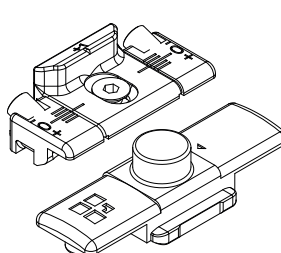

Item code	Description	Interface type	Range (mm)	Version	Base Raw	Anodised Elox	Painted	Trend/Gold Brass	Pieces per pack
01299	INCORRECT MOVEMENT SAFETY DEVICE	C001-C002-C003-C004-C005-C006-C013-C014-C015-C016-C017	H > 620 HC > 250	-	X				10
03520	TEMPLATE FOR AR FUTURA	C001-C002-C003-C004-C005-C006-C011-C012-C013-C014-C015-C016-C017	-	-	X				20
04014K	FUTURA T/T DRIVE ROD	C001-C002-C003-C004-C005-C006-C013-C014-C015-C016-C017	-	-	X				10
04019K	CORNER DRIVE GROOVE 15/20 FUTURA	C001-C002-C003-C004-C005-C006-C009-C010-C011-C012-C013-C014-C015-C016-C017	-	-	X				10
04020K	FUTURA CORNER DRIVE	C001-C002-C003-C004-C005-C006-C009-C010-C011-C012-C013-C014-C015-C016-C017-P001-P002-P003-P004-P005-P006-P007-P008-P009-P010	-	-	X				50
04024K	CORNER DRIVE FOR FUTURA BURGLAR-PROOF FUNCTION	C001-C002-C003-C004-C005-C006-C013-C014-C015-C016-C017	-	-	X				10
04026K	FUTURA T/T BOLT TIP	C001-C002-C003-C005-C006-C013-C014-C015-C017	-	-	X				10
04301K	T/T FUTURA ADDITIONAL ARM	C001-C002-C003-C004-C005-C006	W > 1000	-	X				5
04311	SASH OPENING BLOCK LOCK	C001-C002-C003-C004-C005-C006-C007-C013-C014-C015-C016-C017	-	-	X				10
04770K	FUTURA ADDITIONAL FASTENING MECHANISM	C001-C002-C003-C004-C005-C006-C013-C014-C015-C016-C017	H > 1200 L > 1000	-	X				10
04777K	FUTURA ADDITIONAL FASTENING MECHANISM	C001-C002-C003-C004-C005-C006-C013-C014-C015-C016-C017	H > 1200 L > 1000	Logica	X				50

CONFIGURATION EXAMPLES

FUTURA 3D 80 FLUSH

Micro configuration with Cremone

MAIN SASH			
Sash width [mm]	410 ÷ 700	701 ÷ 1000	1001 ÷ 1700
Hinges	04718	04718	04718
Mechanism	04704	04704	04704
Arm	04284	04285	04285
Additional arm	-	-	04301K
Cremone	01039 - 01094	01039 - 01094	01039 - 01094
SECONDARY SASH			
Hinges	04718	04718	04718
Adapter	04728	04728	04728
Adjustable bolt	02168K	02168K	02168K
Single striker	01348	01348	01348

Micro configuration with window handle

MAIN SASH			
Sash width [mm]	410 ÷ 700	701 ÷ 1000	1001 ÷ 1700
Hinges	04718	04718	04718
Mechanism	0470501	0470501	0470501
Arm	04284	04285	04285
Additional arm	-	-	04301K
Window handle	02476 - 02415 - 00997	02476 - 02415 - 00997	02476 - 02415 - 00997
SECONDARY SASH			
Hinges	04718	04718	04718
Adapter	04728	04728	04728
Adjustable bolt	02168K	02168K	02168K
Single striker	01348	01348	01348

Logica configuration with Cremone

MAIN SASH			
Sash width [mm]	390 ÷ 700	701 ÷ 1000	1001 ÷ 1700
Hinges	04718	04718	04718
Mechanism	04706N	04706N	04706N
Arm	04202	04203	04203
Additional arm	-	-	04301K
Cremone	01192 - 01193	01192 - 01193	01192 - 01193
SECONDARY SASH			
Hinges	04718	04718	04718
Adapter	04728	04728	04728
Adjustable bolt	02168K	02168K	02168K
Single striker	01348	01348	01348

Logica configuration with window handle

MAIN SASH			
Sash width [mm]	390 ÷ 700	701 ÷ 1000	1001 ÷ 1700
Hinges	04718	04718	04718
Mechanism	0470701	0470701	0470701
Arm	04202	04203	04203
Additional arm	-	-	04301K
Window handle	02486	02486	02486
SECONDARY SASH			
Hinges	04718	04718	04718
Adapter	04728	04728	04728
Adjustable bolt	02168K	02168K	02168K
Single striker	01348	01348	01348

Logica micro configuration with Cremone

MAIN SASH			
Sash width [mm]	410 ÷ 700	701 ÷ 1000	1001 ÷ 1700
Hinges	04718	04718	04718
Mechanism	04706N	04706N	04706N
Arm	04344	04345	04345
Additional arm	-	-	04301K
Cremone	01194 - 01195	01194 - 01195	01194 - 01195
SECONDARY SASH			
Hinges	04718	04718	04718
Adapter	04728	04728	04728
Adjustable bolt	02168K	02168K	02168K
Single striker	01348	01348	01348

FUTURA 3D A & F

Functions

Complete system for the construction of tilt-and-turn windows that is specific for arched and sloping window types.

FUTURA ARCO

FUTURA FSQ

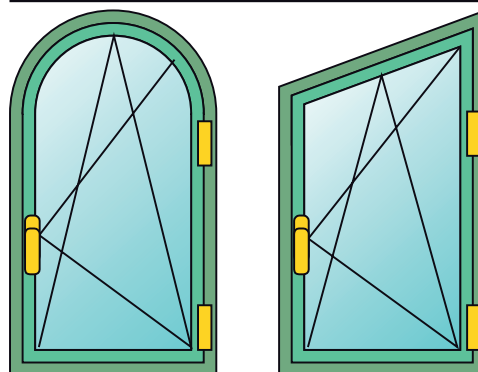

FUTURA 3D
ARCO

FUTURA 3D
FSQ

Technical Features

Making a FUTURA 3D Arched and Sloping tilt-and-turn window mechanism requires:

- Fastening mechanism kit including hinges, arm and hardware
- Cremone or window handle (available in different models to choose from in the specific catalogue section)

Adjustments

The FUTURA 3D tilt-and-turn window enables micrometric adjustment in every direction, ideal after installing the casement.

ADJUSTMENTS [mm]

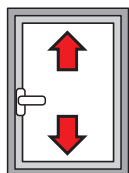

Height:
+1.5 / -0.5

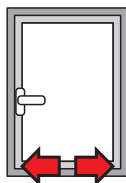

Side:
±1

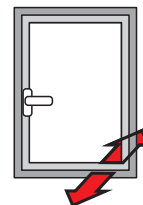

Bottom hinge compression:
±0.3

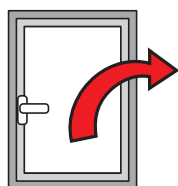

Sash fall:
+2 / -0

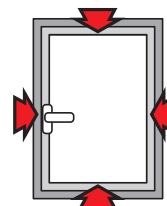

Striker compression:
±1.8

FUTURA 3D
ARCO

FUTURA 3D
FSQ

Futura 3D A & F

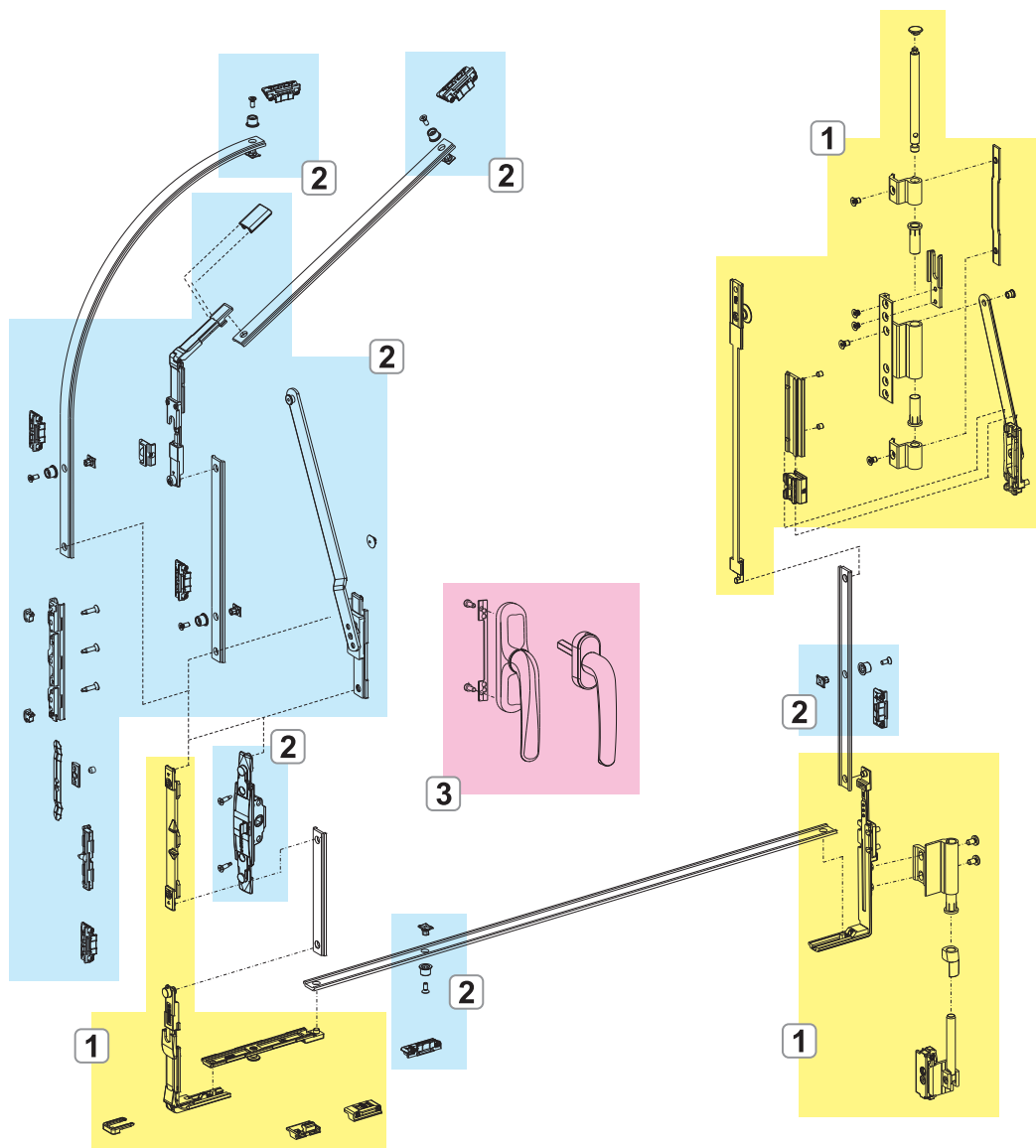

1. FUTURA 3D A & F BASIC MECHANISM
2. FUTURA 3D A & F ADDITIONAL FASTENING MECHANISMS AND ACCESSORIES
3. CREMONES AND WINDOW HANDLES

FUTURA 3D A & F BASIC MECHANISM

Functions

The hinges are supplied completely pre-assembled and ready to be installed on the profile, the hardware consists of ready-assembled accessories that make installation easy and instant.

Materials

Arm

Body, fixing block and slider in zamak with GS Silver Plus finish (up to 500 h of corrosion resistance) and stainless steel rod. Rod, connecting bracket, grub screws and screws in stainless steel. Stop disk in polyamide.

Hinges

Extruded aluminium and brass hinge body Zamak supports with GS Silver Plus finish (up to 500 h corrosion resistance). Pins, screws and grub screws in stainless steel.

Mechanism

Drive, drive rod, bolt tip and strikers in zamak with GS Silver Plus finish (up to 500 h of corrosion resistance). Screws and grub screws in stainless steel. Polyamide raiser.

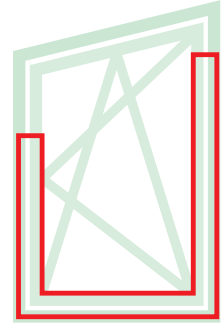

Online data sheet



04671K

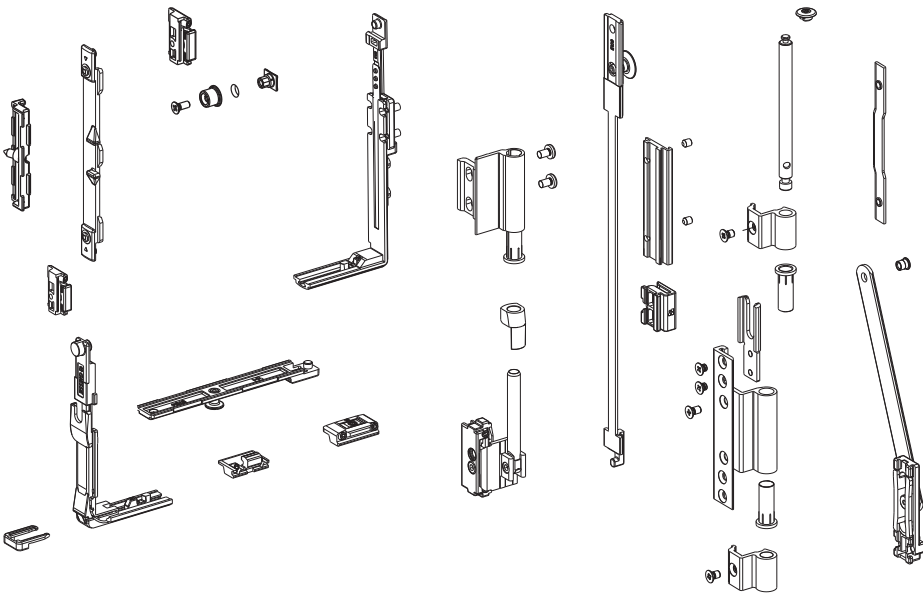

Item code	Description	PROFILE CROSS - SECTION	Base Raw	Anodised Elox	Painted	Trend/Gold Brass	Pieces per pack
04671K	T/T FUTURA ARCHED & SLOPING WINDOW MECHANISM	C001-C002			X	X	5

FUTURA 3D A & F ADDITIONAL FASTENING MECHANISMS AND ACCESSORIES

Functions

The additional arm is mandatory for L>1000 mm. The variable corner drive is fixed without any need for machining the profile, but by means of a polyamide clip and two contrast grub screws. Allows making sloping windows with an angle between the cremone upright and the top cross-beam that goes from 95° to 135°.

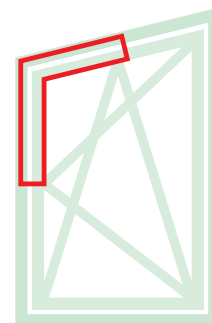

Online data sheet



04023K

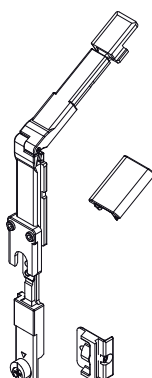

04301K

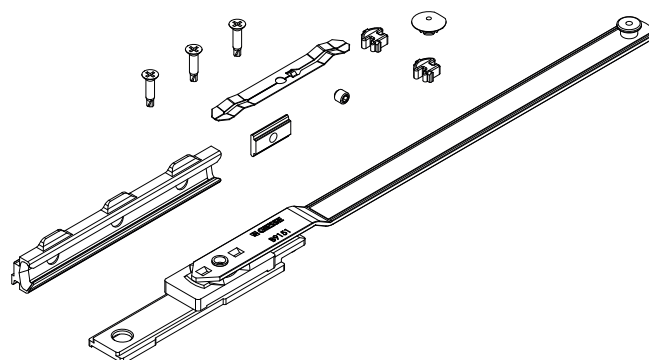

Item code	Description	PROFILE CROSS - SECTION	Range (mm)	Version	Base Raw	Anodised Elox	Painted	Trend/Gold Brass	Pieces per pack
04023K	VARIABLE CORNER DRIVE	C001-C002	-	-	X				10
04301K	T/T FUTURA ADDITIONAL ARM	C001-C002-C003-C004-C005-C006	W > 1000	-	X				5

CONFIGURATION EXAMPLES

FUTURA 3D A & F

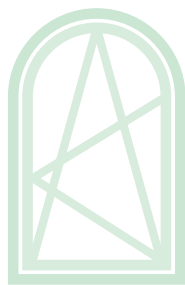

Basic arched configuration with Cremone

MAIN SASH		
Sash width	320 ÷ 1000	1001 ÷ 1700
Mechanism	04671K	04671K
Additional arm	-	04301K
Cremone	01039 - 01090K	01039 - 01090K

Basic arched configuration with window handle

MAIN SASH		
Sash width	320 ÷ 1000	1001 ÷ 1700
Mechanism	04671K	04671K
Mechanism	01061	01061
Additional arm	-	04301K
Window handle	02476 - 02415 - 00997	02476 - 02415 - 00997

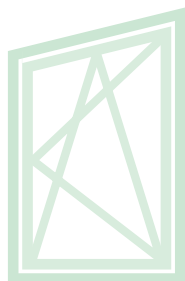

Basic sloping window configuration with Cremone

MAIN SASH		
Sash width	320 ÷ 1000	1001 ÷ 1700
Mechanism	04671K	04671K
Variable corner drive	04023K	04023K
Additional arm	-	04301K
Cremone	01039 - 01090K	01039 - 01090K

Basic sloping window configuration with window handle

MAIN SASH		
Sash width	320 ÷ 1000	1001 ÷ 1700
Mechanism	04671K	04671K
Mechanism	01061	01061
Variable corner drive	04023K	04023K
Additional arm	-	04301K
Window handle	02476 - 02415 - 00997	02476 - 02415 - 00997

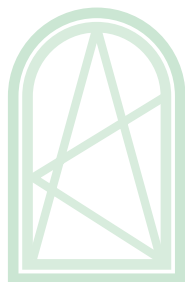

Basic arched configuration with NP Supra

MAIN SASH		
Sash width	320 ÷ 1000	1001 ÷ 1700
Mechanism	04671K	04671K
Mechanism	0395301	0395301
Additional arm	-	04301K
NP Supra	03962 - 03963	03962 - 03963

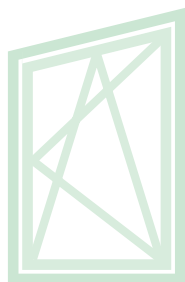

Basic sloping window configuration with NP Supra

MAIN SASH		
Sash width	320 ÷ 1000	1001 ÷ 1700
Mechanism	04671K	04671K
Mechanism	0395301	0395301
Variable corner drive	04023K	04023K
Additional arm	-	04301K
NP Supra	03962 - 03963	03962 - 03963

FUTURA 3D R

Functions

Complete system for the construction of tilt-and-turn windows with load capacities of up to 110 kg. Available in the standard and logica versions.

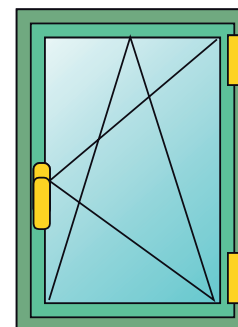

Technical Features

Making a FUTURA 3D R tilt-and-turn window mechanism requires:

- Hinge kit
- Set of fastening mechanisms for Cremones and window handles
- Arms, available in two versions (standard and logic).
- Cremona or window handle (available in different models to choose from in the specific catalogue section)

Adjustments

The FUTURA 3D tilt-and-turn window enables micrometric adjustment in every direction, ideal after installing the casement.

Logica

The logica operation consists in first tilt-and-turn opening (with the cremona at 90°) and secondly side-hung opening (with the cremona at 180°). Its use is particularly recommended in public buildings (schools, hospitals, etc.) in combination with a cremona with a key in order to have only tilt-and-turn window opening for safety reasons and to allow full opening only for staff with the key.

ADJUSTMENTS [mm]

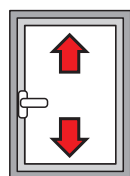

Height:
+1.5 / -0.5

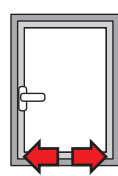

Side:
±1,2

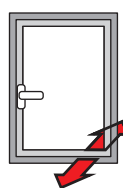

Bottom hinge compression:
±0.3

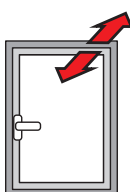

Top hinge compression:
±1.5

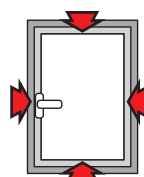

Striker compression:
±1,2

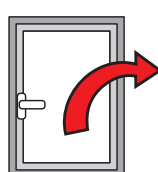

Sash fall:
+4 / -2

Logica mechanism operation

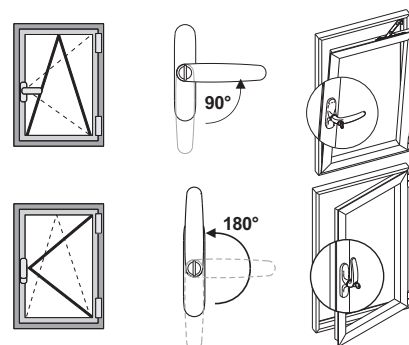

Table of maximum glass thickness [mm]

2500	35	29	25	22	19	17	16	14	13	12	12	11	10	
2400	36	30	26	22	20	18	16	15	14	13	12	11	11	
2300	38	31	27	23	21	19	17	16	14	13	13	12	11	
2200	39	33	28	25	22	20	18	16	15	14	13	12	12	
2100	41	34	29	26	23	21	19	17	16	15	14	13	12	
2000	43	36	31	27	24	22	20	18	17	15	14	13	13	
1900	45	38	32	28	25	23	21	19	17	16	15	14	13	
1800	48	40	34	30	27	24	22	20	18	17	16	15	14	
1700	50	42	36	32	28	25	23	21	20	18	17	15	14	
1600	50	45	39	34	30	27	25	22	21	19	17	15	14	
1500	50	48	41	36	32	29	26	24	22	20	17	15	14	
1400	50	50	44	39	34	31	28	26	23	20	17	15	14	
1300	50	50	47	42	37	33	30	27	23	20	17	15		
1200	50	50	50	45	40	36	32	27	23	20	17			
1100	50	50	50	49	44	39	32	27	23	20				
1000	50	50	50	50	48	39	32	27	23					
900	50	50	50	50	48	39	32	27						
800	50	50	50	50	48	39	32							
700	50	50	50	50	48	39								
600	390	500	600	700	800	900	1000	1100	1200	1300	1400	1500	1600	1700

Table of maximum load capacity [kg]

2500	110	110	110	110	110	110	110	110	110	110	110	110	110	
2400	110	110	110	110	110	110	110	110	110	110	110	110	110	
2300	110	110	110	110	110	110	110	110	110	110	110	110	110	
2200	110	110	110	110	110	110	110	110	110	110	110	110	110	
2100	110	110	110	110	110	110	110	110	110	110	110	110	110	
2000	110	110	110	110	110	110	110	110	110	110	110	110	110	
1900	110	110	110	110	110	110	110	110	110	110	110	110	110	
1800	110	110	110	110	110	110	110	110	110	110	110	110	106	
1700	110	110	110	110	110	110	110	110	110	110	110	106	100	
1600	110	110	110	110	110	110	110	110	110	110	107	100	94	
1500	110	110	110	110	110	110	110	110	110	110	100	94	88	
1400	110	110	110	110	110	110	110	110	108	100	83	88	82	
1300	110	110	110	110	110	110	110	108	100	93	87	81		
1200	110	110	110	110	110	110	108	100	92	86	80			
1100	110	110	110	110	110	100	92	85	79	73				
1000	110	110	110	110	100	91	83	77	72					
900	110	110	110	100	90	82	75	69						
800	110	110	100	89	80	73	67							
700	110	100	88	78	70	64								
600	390	500	600	700	800	900	1000	1100	1200	1300	1400	1500	1600	1700

FUTURA 3D
R

Futura 3D R traditional

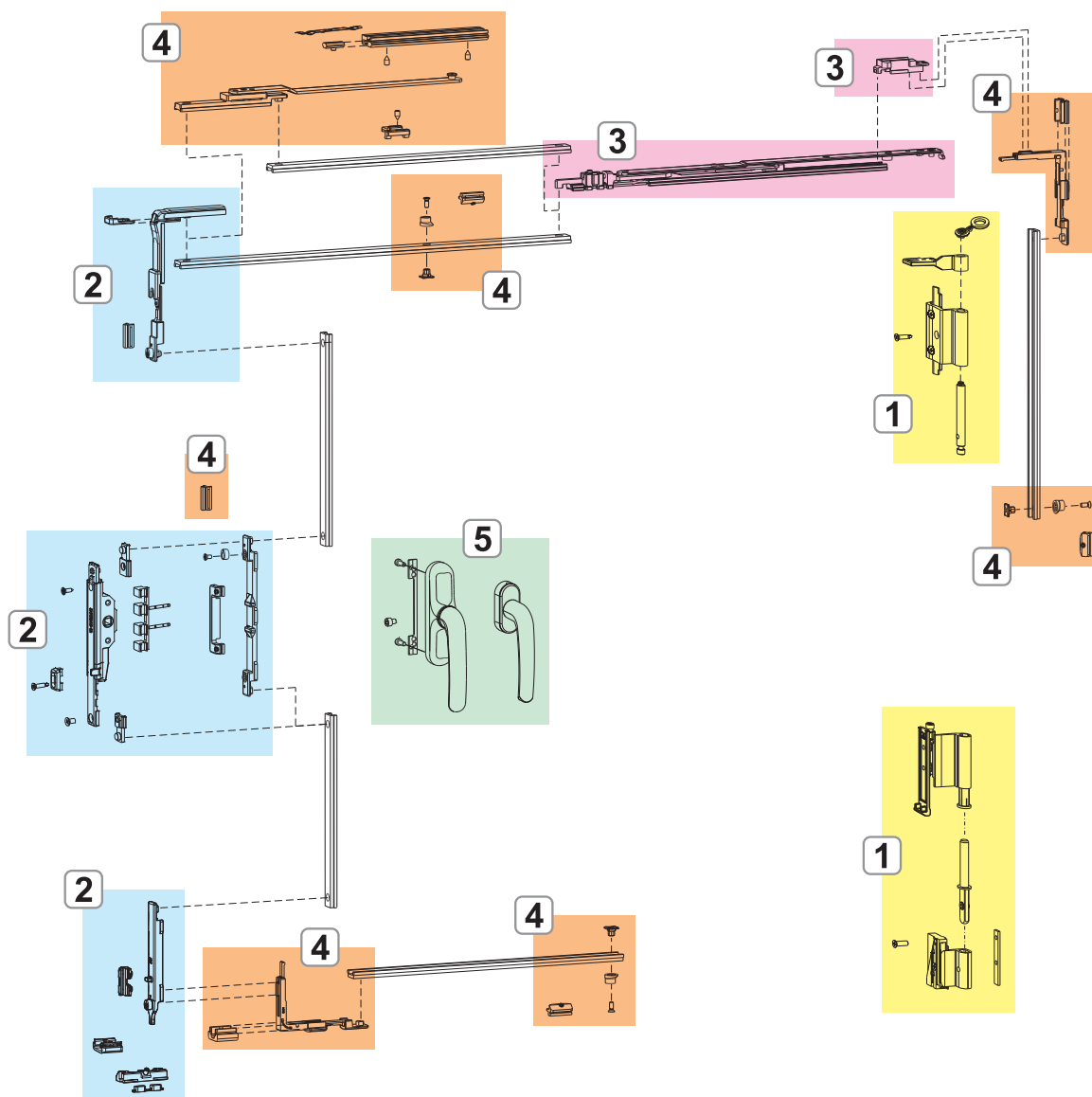

- 1. FUTURA 3D R HINGES
- 2. FUTURA 3D R FASTENING MECHANISMS
- 3. FUTURA 3D R ARMS
- 4. FUTURA 3D R ADDITIONAL FASTENING MECHANISMS AND ACCESSORIES
- 5. CREMONES AND WINDOW HANDLES



Futura 3D R logica

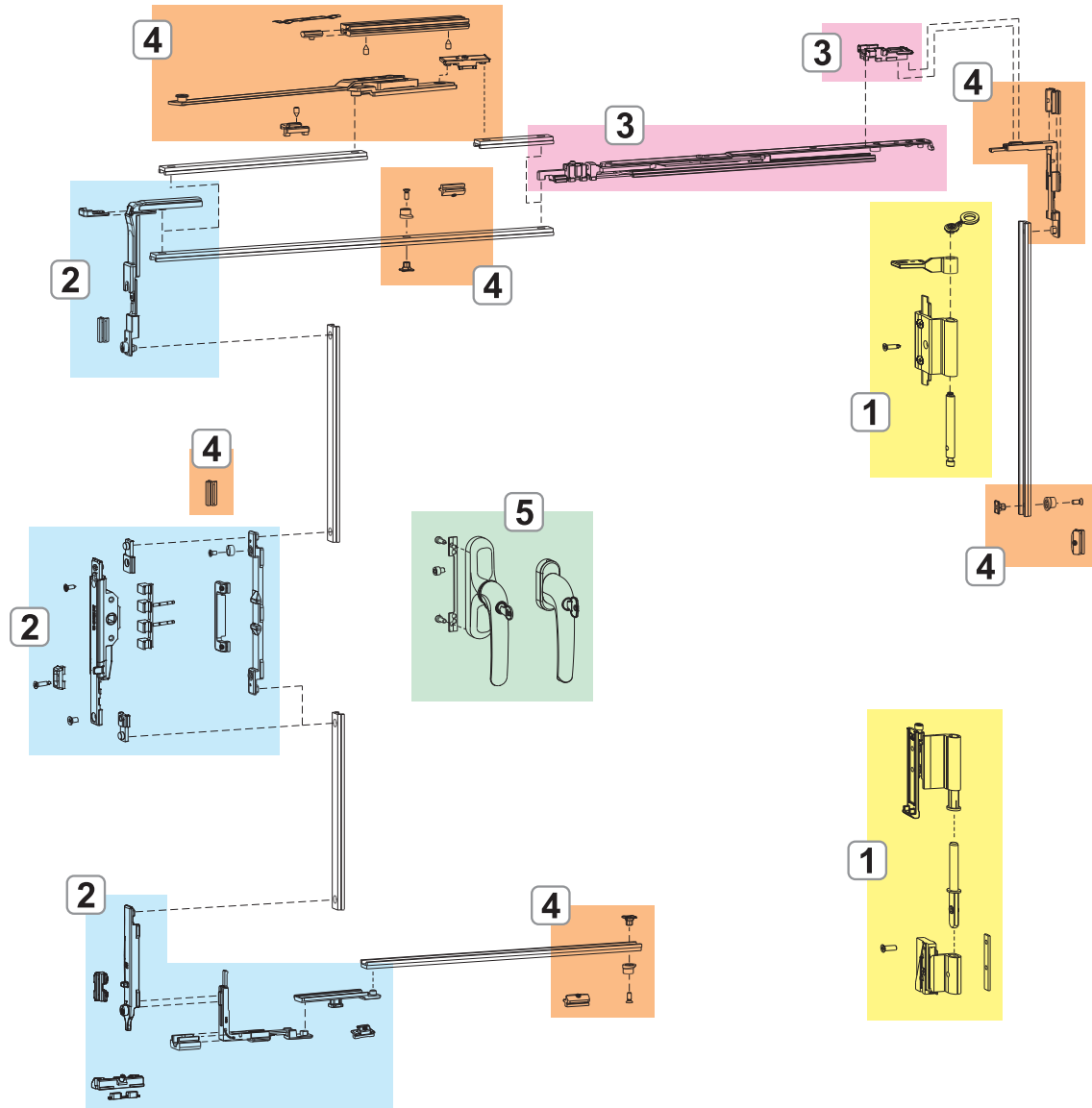

1. FUTURA 3D R HINGES
2. FUTURA 3D R FASTENING MECHANISMS
3. FUTURA 3D R ARMS
4. FUTURA 3D R ADDITIONAL FASTENING MECHANISMS AND ACCESSORIES
5. CREMONES AND WINDOW HANDLES

FUTURA 3D R HINGES

Functions

Hinge set (upper and lower), completely pre-assembled and ready to be installed on the profile.

Materials

Body of hinges in extruded aluminium and brass.

Supports in zamak with GS Silver Plus finish (up to 500 hr corrosion resistance).

Pins, screws and grub screws in stainless steel.

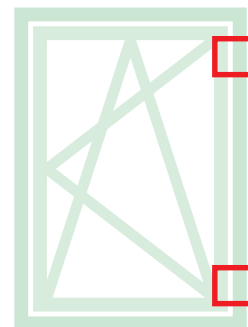

Online data sheet



04721

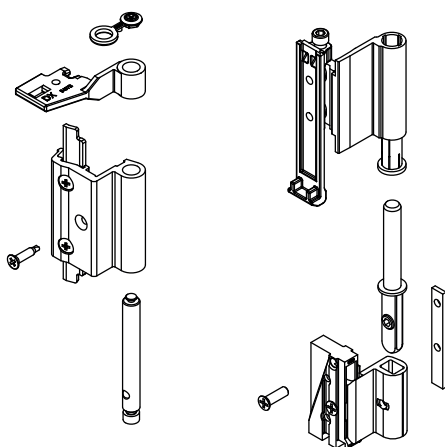

Item code	Description	PROFILE CROSS - SECTION	Base Raw	Anodised Elox	Painted	Trend/Gold Brass	Pieces per pack
04721	HINGE T/T FUTURA 3D R	C007	X		X	X	10

FUTURA 3D R FASTENING MECHANISMS

Functions

Tilt-and-turn window fastening mechanisms for cremone or window handle, available in Base and Logica versions.

Materials

Drive, drive rod, mechanism bolt tip and strikers in zamak with GS Silver Plus finish (up to 500 h of corrosion resistance).

Screws and grub screws in stainless steel.

Polyamide raiser.

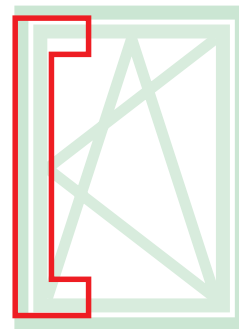

Online data sheet

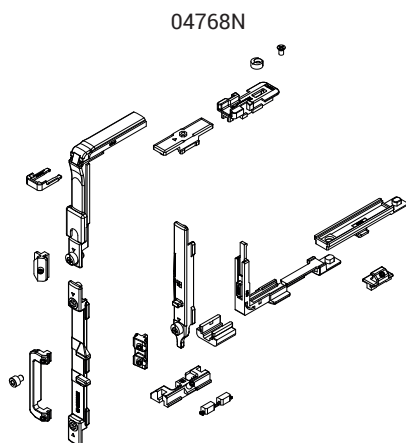
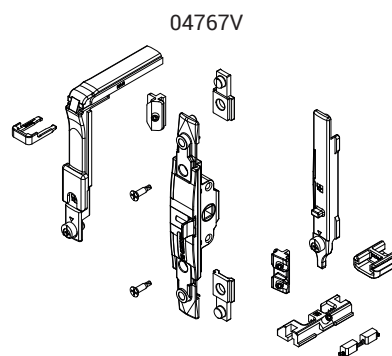
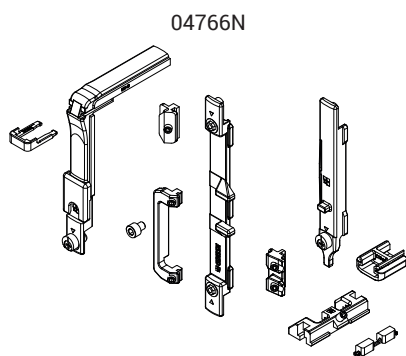

Item code	Description	PROFILE CROSS - SECTION	Mechanism	Version	Base Raw	Anodised Elox	Painted	Trend/Gold Brass	Pieces per pack
04766N	T/T FASTENING MECHANISM	C007	Cremone	-	X				10
04767V	T/T M 180 FASTENING MECHANISM	C007	Window handle	-	X				10
04768N	T/T LOGICA FASTENING MECHANISM	C007	Cremone	Logica	X				10

FUTURA 3D R ARMS

Functions

They enable tilt-and-turn opening combined with the mechanisms.

Materials

Body, fixing block and slider in zamak with GS Silver Plus finish (up to 500 h of corrosion resistance).
Rod, connecting bracket, grub screws and screws in stainless steel. Stop disk in polyamide.

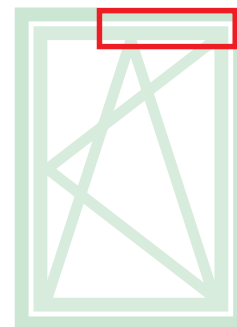

Online data sheet



04380

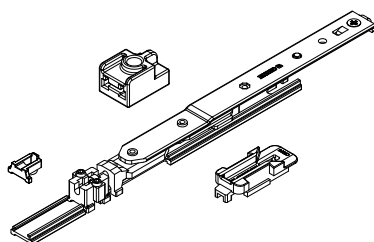

0422901

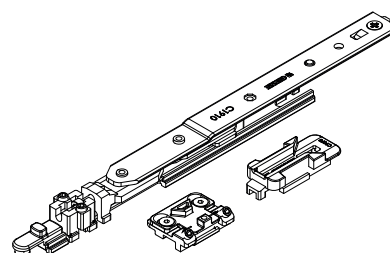

0423001

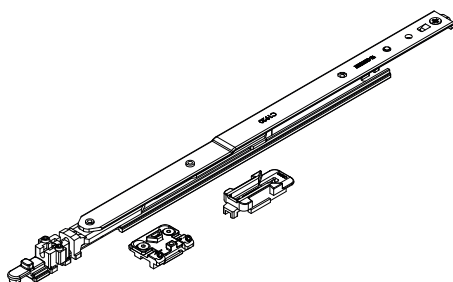

Item code	Description	PROFILE CROSS - SECTION	Range (mm)	Base Raw	Anodised Elox	Painted	Trend/Gold Brass	Pieces per pack
04380	ARM TYPE 0 T/T FUTURA R	C007	W 360 ÷ 425	X				10
0422901	ARM TYPE 1 T/T FUTURA R	C007	L 426 ÷ 580	X				10
0423001	ARM TYPE 2 T/T FUTURA R	C007	L 581 ÷ 1700	X				10

FUTURA 3D R ADDITIONAL FASTENING MECHANISMS AND ACCESSORIES

Functions

The additional fasteners make it possible to add further fastening elements that either increase the dimensions of the casement or that can be used when locking points are needed on the cross beams or hinge-side upright.

On the basis of the dimensions of the casement, additional fasteners (for H>1200 mm and W>1000 mm) and the additional arm (which is mandatory for W>1000 mm) are to be used in combination with this mechanism.

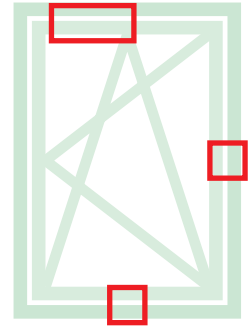

Online data sheet



04017K

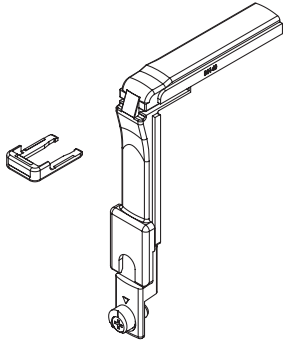

04308K

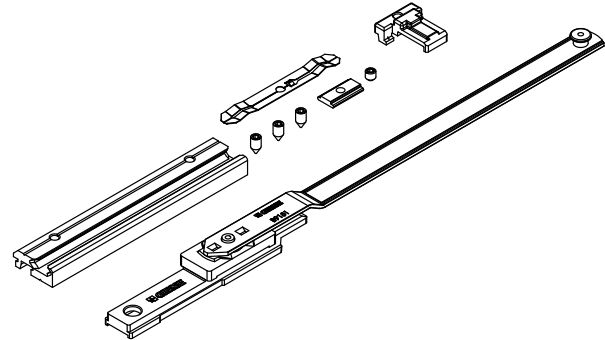

04311

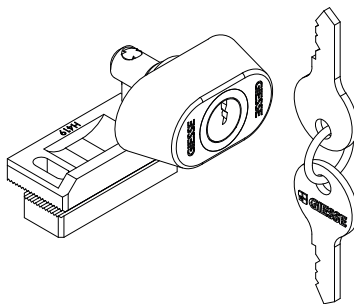

04648K

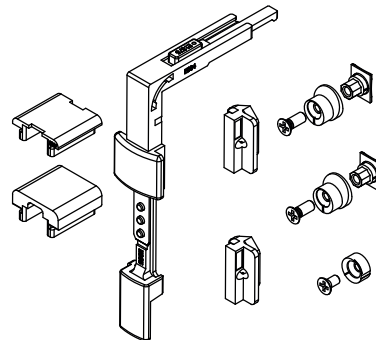

Item code	Description	PROFILE CROSS - SECTION	Range (mm)	Base Raw	Anodised Elox	Painted	Trend/Gold Brass	Pieces per pack
04017K	FUTURA CORNER DRIVE	C007		X				10
04308K	ADDITIONAL ARM FOR T/T	C007	W > 1000	X				5
04311	SASH OPENING BLOCK LOCK	C001-C002-C003-C004-C005-C006-C007-C013-C014-C015-C016-C017	-	X				10
04648K	VERT/HOR.ADD.FAST. GS999	C007	H > 1200 L > 1000	X				10

FUTURA 3D R SECONDARY SASH HINGE KIT

Functions

FUTURA 3D R features specific hinges for the secondary sash, with the same styling line and the same adjustments.

Materials

Body of hinges in extruded aluminium and brass.

Supports in zamak with GS Silver Plus finish (up to 500 hr corrosion resistance).

Pins, screws and grub screws in stainless steel.

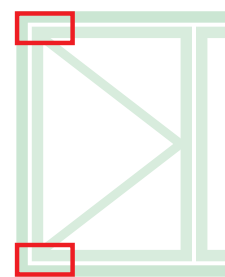

Online data sheet



04721

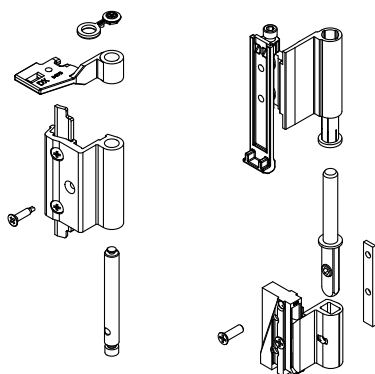

04423

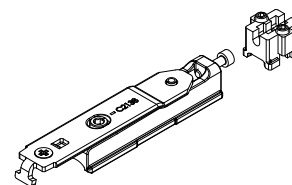

Mandatory to use the FRIZ arm

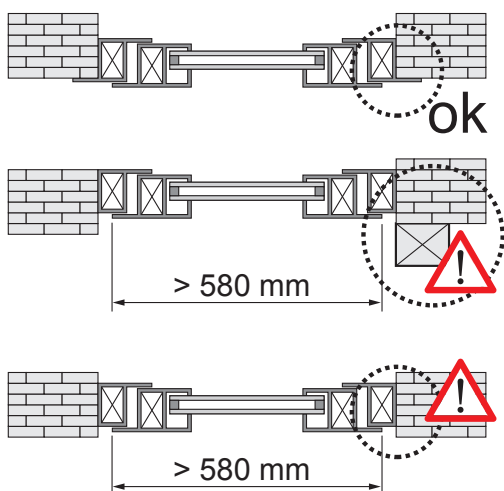

FRIZ arm positioning

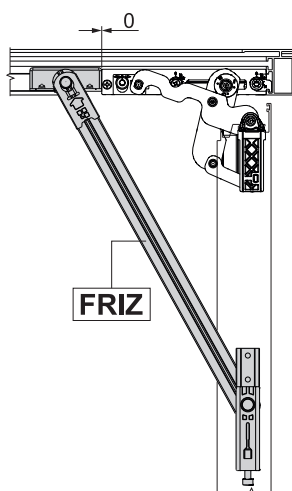

Opening angle with FRIZ arm

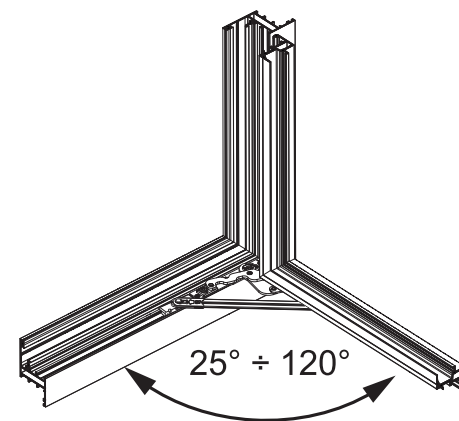

Item code	Description	PROFILE CROSS - SECTION	Base Raw	Anodised Elox	Painted	Trend/Gold Brass	Pieces per pack
04721	HINGE T/T FUTURA 3D R	C007	X		X	X	10
04423	ERRE - SEC. SASH ADAPTER	C007	X				10

CONFIGURATION EXAMPLES

FUTURA 3D R

Basic configuration with Cremone

MAIN SASH			
Sash width	426 ÷ 580	581 ÷ 1000	1001 ÷ 1700
Hinges	04721	04721	04721
Mechanism	04766N	04766N	04766N
Arm	0422901	0423001	0423001
Additional arm	-	-	04308K
Cremone	01039 - 01090K	01039 - 01090K	01039 - 01090K
SECONDARY SASH			
Hinges	04721	04721	04721
Adapter	04423	04423	04423
Two-way bolt	04231	04231	04231

Basic configuration with window handle

MAIN SASH			
Sash width	426 ÷ 580	581 ÷ 1000	1001 ÷ 1800
Hinges	04721	04721	04721
Mechanism	04767V	04767V	04767V
Arm	0422901	0423001	0423001
Additional arm	-	-	04308K
Window handle	02476 - 02415 - 00997	02476 - 02415 - 00997	02476 - 02415 - 00997
SECONDARY SASH			
Hinges	04721	04721	04721
Adapter	04423	04423	04423
Two-way bolt	04231	04231	04231

Logica configuration with Cremone

MAIN SASH			
Sash width	426 ÷ 580	581 ÷ 1000	1001 ÷ 1700
Hinges	04721	04721	04721
Mechanism	04768N	04768N	04768N
Arm	0422901	0423001	0423001
Additional arm	-	-	04308K
Cremone	01192 - 01193	01192 - 01193	01192 - 01193
SECONDARY SASH			
Hinges	04721	04721	04721
Adapter	04423	04423	04423
Two-way bolt	04231	04231	04231

Logica configuration with window handle

MAIN SASH			
Sash width	426 ÷ 580	581 ÷ 1000	1001 ÷ 1700
Hinges	04721	04721	04721
Mechanism	04768N	04768N	04768N
Mechanism	01062	01062	01062
Arm	0422901	0423001	0423001
Additional arm	-	-	04308K
Window handle	02486	02486	02486
SECONDARY SASH			
Hinges	04721	04721	04721
Adapter	04423	04423	04423
Two-way bolt	04231	04231	04231

CLASSIC 3D 80

CLASSIC 3D
80

Functions

Complete system for the construction of tilt-and-turn windows with load capacities of up to 80 kg.
Available in the standard, logic and microventilation versions.

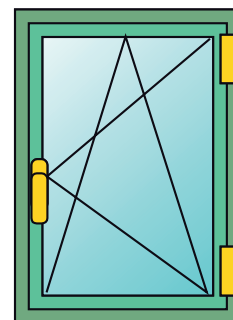

CLASSIC 3D
80 micro

CLASSIC 3D
80 lgc

Technical Features

Making a CLASSIC 3D 80 tilt-and-turn window mechanism requires:

- Hinge kit
- Set of fastening mechanisms for Cremones and window handles
- Arms, available in three versions (standard, micro-ventilation and logic)
- Cremona or window handle (available in different models to choose from in the specific catalogue section)

Adjustments

The CLASSIC 3D tilt-and-turn window enables micrometric adjustment in every direction, ideal after installing the casement.

Micro-ventilation

Microventilation enables having simultaneously both the tilt-and-turn position and micro-ventilation (precision opening of the sash) on the casement.

Logica

The logical operation consists in first tilt-and-turn opening (with the cremona at 90°) and secondly side-hung opening (with the cremona at 180°). Its use is particularly recommended in public buildings (schools, hospitals, etc.) in combination with a cremona with a key in order to have only tilt-and-turn window opening for safety reasons and to allow full opening only for staff with the key.

Logica mechanism operation

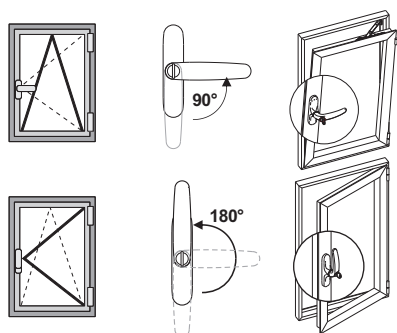

Standard microventilation

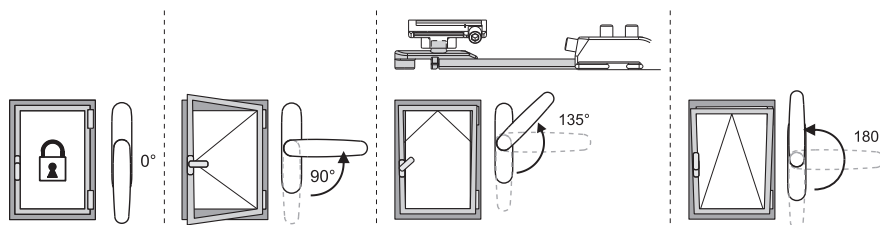

ADJUSTMENTS [mm]

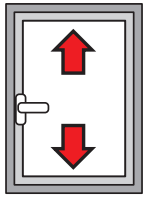

Height:
+1.5 / -0.5

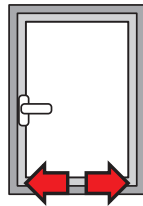

Side:
±1

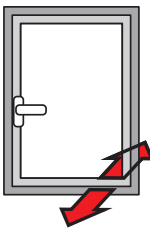

Bottom hinge compression:
±0.3

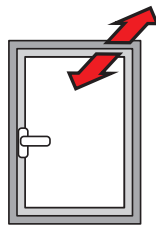

Top hinge compression:
±1.5

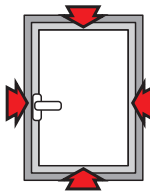

Striker compression:
±1.8

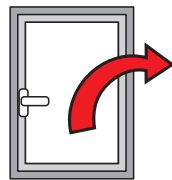

Sash fall:
+3.5 / -1.5

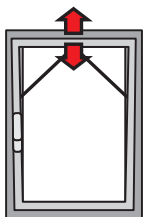

Micro-ventilation:
+3.6 / -1.8

Table of maximum glass thickness [mm]

2500										
2400	25	21	18	16	14	13	11	10	10	
2300	26	22	19	16	15	13	12	11	10	
2200	27	23	19	17	15	14	12	11	10	
2100	29	24	20	18	16	14	13	12	11	
2000	30	25	21	19	17	15	14	12	11	
1900	31	26	22	20	17	16	14	13	12	
1800	33	28	24	21	18	17	15	14	13	
1700	35	29	25	22	19	17	16	15	13	
1600	37	31	26	23	21	18	17	15	14	
1500	39	33	28	25	22	20	18	16	15	
1400	42	35	30	26	23	21	19	17	16	
1300	45	37	32	28	25	22	20	19	17	
1200	48	40	34	30	27	24	22	20	17	
1100	50	44	37	33	29	26	24	20	17	
1000	50	48	41	36	32	29	24	20		
900	50	50	45	39	35	29	24			
800	50	50	50	44	35	29				
700	50	50	50	45	35					
600	50	50	50	45						
	350	500	600	700	800	900	1000	1100	1200	1300

Table of maximum load capacity [kg]

2500										
2400	80	80	80	80	80	80	80	80	80	80
2300	80	80	80	80	80	80	80	80	80	80
2200	80	80	80	80	80	80	80	80	80	80
2100	80	80	80	80	80	80	80	80	80	80
2000	80	80	80	80	80	80	80	80	80	80
1900	80	80	80	80	80	80	80	80	80	80
1800	80	80	80	80	80	80	80	80	80	80
1700	80	80	80	80	80	80	80	80	80	80
1600	80	80	80	80	80	80	80	80	80	80
1500	80	80	80	80	80	80	80	80	80	80
1400	80	80	80	80	80	80	80	80	80	80
1300	80	80	80	80	80	80	80	80	78	78
1200	80	80	80	80	80	80	79	73	67	
1100	80	80	80	80	80	80	73	67		
1000	80	80	80	80	80	73	66			
900	80	80	80	80	73	66				
800	80	80	80	73	65					
700	80	80	80	73	64					
600	80	80	73	64						
	350	500	600	700	800	900	1000	1100	1200	1300

CLASSIC 3D
80 micro

Classic 3D 80 traditional

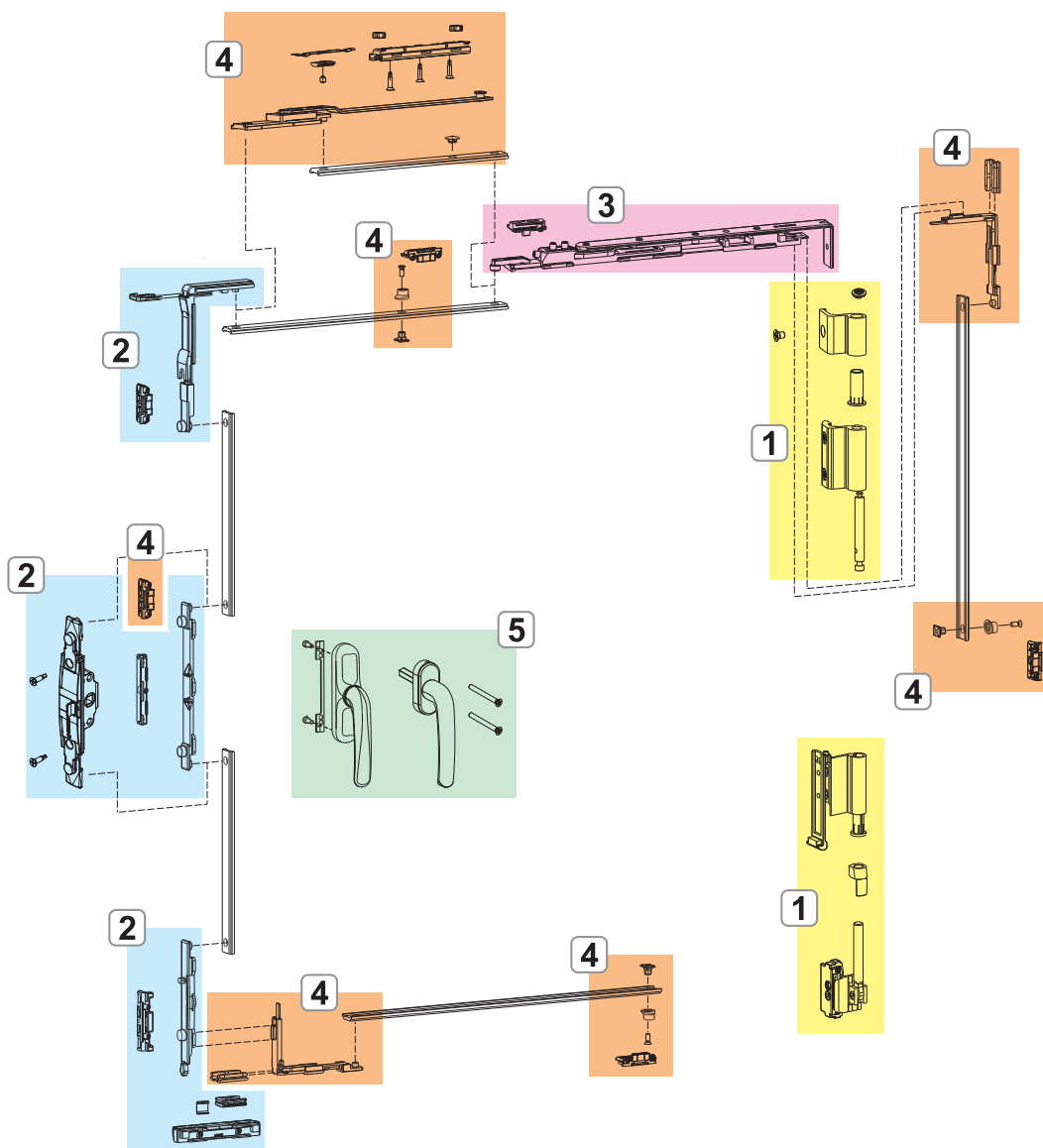

- 1. CLASSIC 3D 80 HINGES
- 2. CLASSIC 3D 80 FASTENING MECHANISMS
- 3. CLASSIC 3D 80 ARMS
- 4. CLASSIC 3D 80 ADDITIONAL FASTENING MECHANISMS AND ACCESSORIES
- 5. CREMONES AND WINDOW HANDLES

CLASSIC 3D
80 lgc

Classic 3D 80 logica

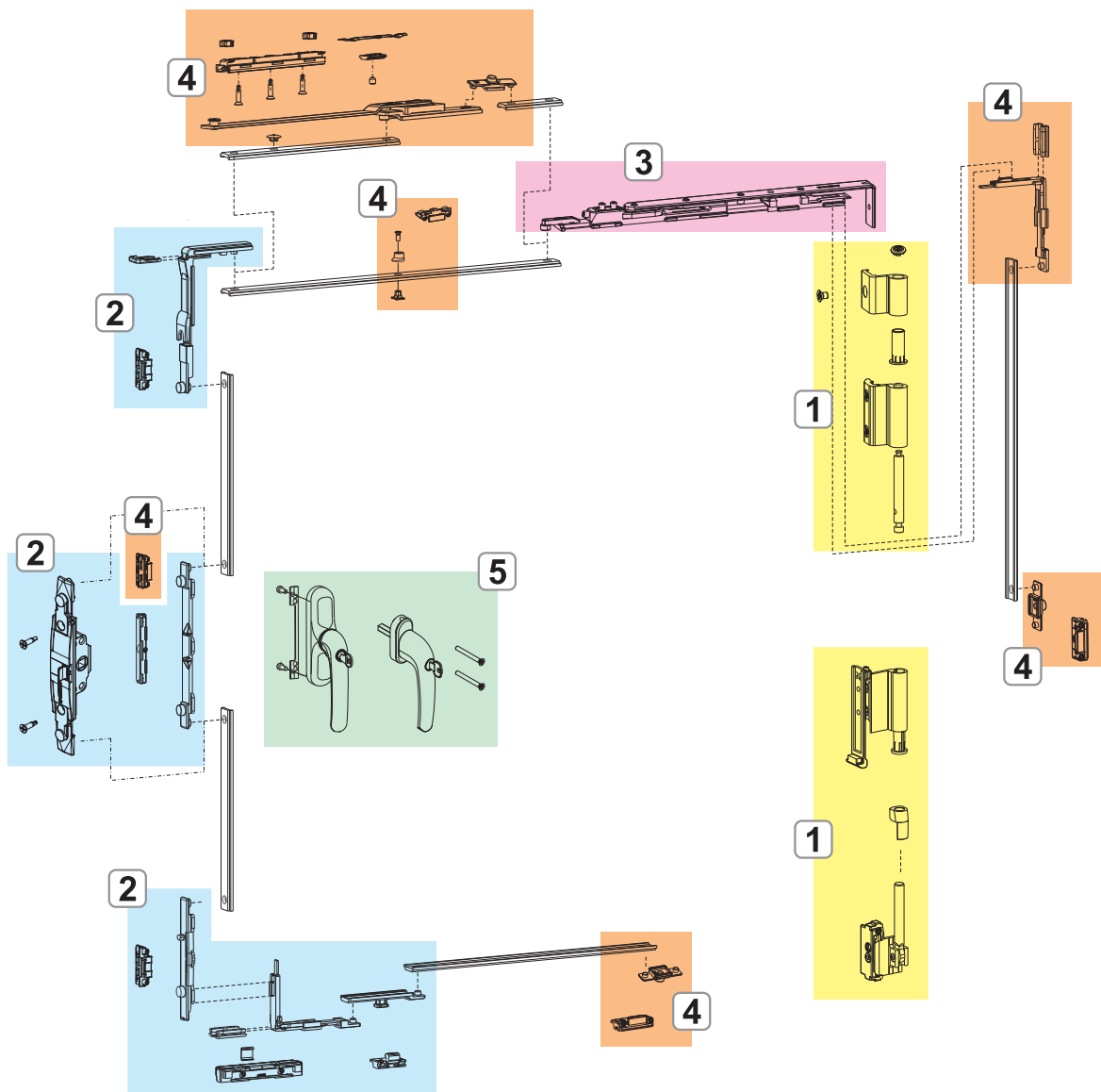

1. CLASSIC 3D 80 HINGES
2. CLASSIC 3D 80 FASTENING MECHANISMS
3. CLASSIC 3D 80 ARMS
4. CLASSIC 3D 80 ADDITIONAL FASTENING MECHANISMS AND ACCESSORIES
5. CREMONES AND WINDOW HANDLES

CLASSIC 3D 80 HINGES

Functions

Hinge set (upper and lower), completely pre-assembled and ready to be installed on the profile.

Materials

Extruded aluminium hinge body.

Supports in zamak with GS Silver Plus finish (up to 500 hr corrosion resistance).

Pins, screws and grub screws in stainless steel.

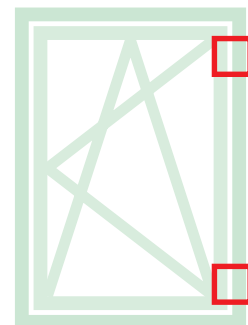

Online data sheet



04739

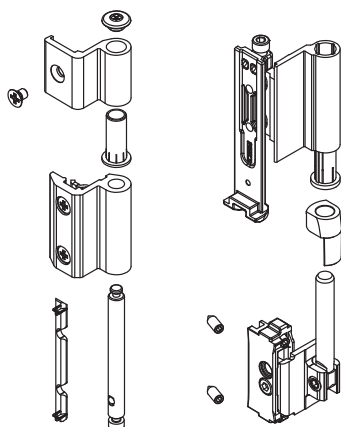

Table of maximum glass thickness [mm]

2500	25	21	18	16	14	13	11	10	10
2400	26	22	19	16	15	13	12	11	10
2300	27	23	19	17	15	14	12	11	10
2200	29	24	20	18	16	14	13	12	11
2100	30	25	21	19	17	15	14	12	11
2000	31	26	22	20	17	16	14	13	12
1900	33	28	24	21	18	17	15	14	13
1800	35	29	25	22	19	17	16	15	13
1700	37	31	26	23	21	18	17	15	14
1600	39	33	28	25	22	20	18	16	15
1500	42	35	30	26	23	21	19	17	16
1400	45	37	32	28	25	22	20	19	17
1300	48	40	34	30	27	24	22	20	17
1200	50	44	37	33	29	26	24	20	17
1100	50	48	41	36	32	29	24	20	
1000	50	50	45	39	35	29	24		
900	50	50	50	44	35	29			
800	50	50	50	45	35				
700	50	50	50	45					
600	50	50	50	45					

Table of maximum load capacity [kg]

2500	80	80	80	80	80	80	80	80	80
2400	80	80	80	80	80	80	80	80	80
2300	80	80	80	80	80	80	80	80	80
2200	80	80	80	80	80	80	80	80	80
2100	80	80	80	80	80	80	80	80	80
2000	80	80	80	80	80	80	80	80	80
1900	80	80	80	80	80	80	80	80	80
1800	80	80	80	80	80	80	80	80	80
1700	80	80	80	80	80	80	80	80	80
1600	80	80	80	80	80	80	80	80	80
1500	80	80	80	80	80	80	80	80	80
1400	80	80	80	80	80	80	80	80	80
1300	80	80	80	80	80	80	80	80	78
1200	80	80	80	80	80	80	80	79	73
1100	80	80	80	80	80	80	79	73	67
1000	80	80	80	80	80	80	73	67	
900	80	80	80	80	80	73	66		
800	80	80	80	80	73	66			
700	80	80	80	73	65				
600	80	80	73	64					

Item code	Description	PROFILE CROSS - SECTION	Base Raw	Anodised Elox	Painted	Trend/Gold Brass	Pieces per pack
04739	HINGE T/T CLASSIC 80	C001-C002-C003-C005	X	X	X		10

CLASSIC 3D 80 INDUSTRIAL HINGES

Functions

Hinge set (upper and lower), completely pre-assembled and ready to be installed on the profile.

Materials

Extruded aluminium hinge body.

Supports in zamak with GS Silver Plus finish (up to 500 hr corrosion resistance).

Pins, screws and grub screws in stainless steel.

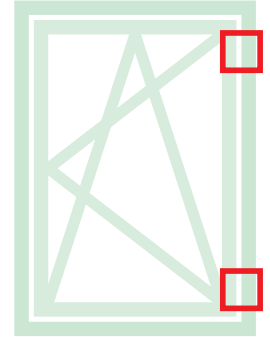

Online data sheet

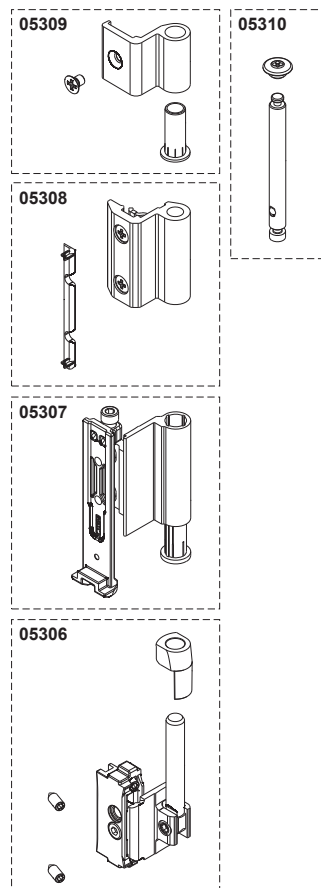

Item code	Description	PROFILE CROSS - SECTION	Base Raw	Anodised Elox	Painted	Trend/Gold Brass	Pieces per pack
05306	CLASSIC - BOTTOM FRAME HINGE	C001-C002-C003-C005			X		50
05307	CLASSIC - BOTTOM SASH HINGE	C001-C002-C003-C005			X		50
05308	CLASSIC - TOP FRAME HINGE	C001-C002-C003-C005			X		50
05309	CLASSIC - TOP SASH HINGE	C001-C002-C003-C005			X		50
05310	CLASSIC - PIN KIT	C001-C002-C003-C005	X				50

CLASSIC 3D 80 FASTENING MECHANISMS

Functions

Tilt-and-turn window fastening mechanisms for cremone or window handle, available in Base and Logica versions.

Materials

Drive, drive rod, mechanism bolt tip and strikers in zamak with GS Silver Plus finish (up to 500 h of corrosion resistance).

Screws and grub screws in stainless steel.

Polyamide raiser.

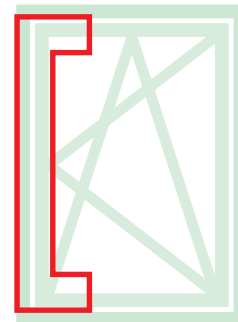

Online data sheet

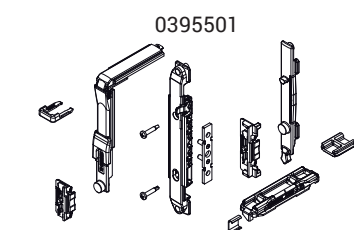

0395501

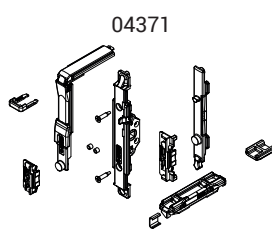

04371

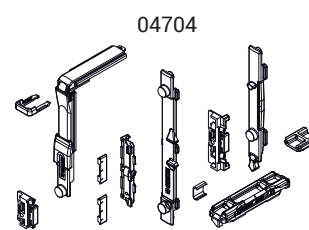

04704

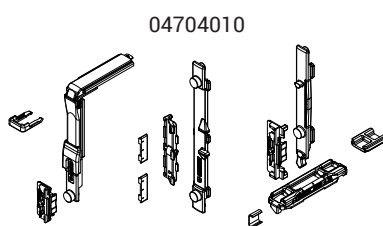

04704010

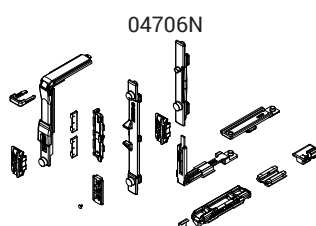

04706N

Item code	Description	PROFILE CROSS - SECTION	Mechanism	Version	Base Raw	Anodised Elox	Painted	Trend/Gold Brass	Pieces per pack
0395501	T/T FASTENING MECHANISM	C001-C002-C003-C005-C006-C013-C014-C015-C017	NP SUPRA	-	X				10
04371	FASTENING MECHANISM T/T MOVEMENT M 180	C001-C002-C004-C005-C006-C013-C014-C015-C016-C017	Window handle	-	X				10
04704	T/T FASTENING MECHANISM	C001-C002-C004-C005-C006-C013-C014-C015-C016-C017	Cremone	-	X				10
04704010	T/T FASTENING MECHANISM	C003	Cremone	-	X				10
04706N	T/T LOGICA FASTENING MECHANISM	C001-C002-C004-C005-C006-C013-C014-C015-C016-C017	Cremone	Logica	X				10

CLASSIC 3D 80 INDUSTRIAL FASTENING MECHANISMS

Functions

Tilt-and-turn window fastening mechanisms for cremone or window handle, available in Base and Logica versions.

Materials

Drive, drive rod, mechanism bolt tip and strikers in zamak with GS Silver Plus finish (up to 500 h of corrosion resistance).

Screws and grub screws in stainless steel.

Polyamide raiser.

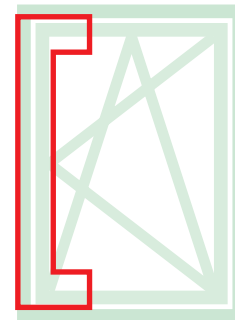

Online data sheet

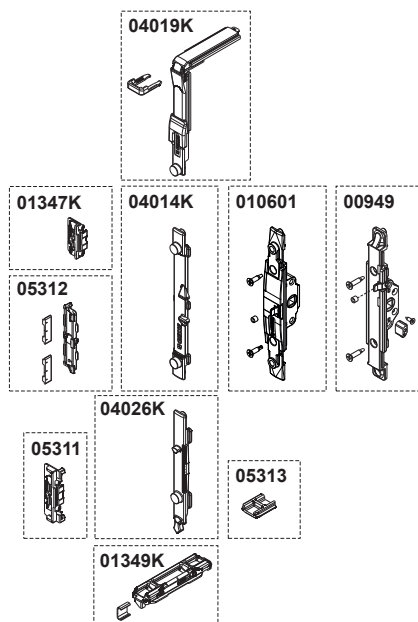

Item code	Description	PROFILE CROSS - SECTION	Base Raw	Anodised Elox	Painted	Trend/Gold Brass	Pieces per pack
00949	ONE-WAY MECHANISM M180	C001-C002-C003-C004-C005-C006-C012-C013-C014-C015-C016-C017	X				10
0106101	ONE-WAY MECHANISM	C001-C002-C003-C004-C005-C006-C012-C013-C014-C015-C016-C017	X				10
01347K	SINGLE ADJUSTABLE STRIKER	C001-C002-C003-C005-C011-C013-C014-C015-C016-C017-P001-P002-P004-P005-P006-P008-P009	X				200
01349K	ZAMAK DOUBLE STRIKER	C001-C002-C003-C004-C006-C011-C010-C011-C013-C014-C015	X				100
04014K	FUTURA T/T DRIVE ROD	C001-C002-C003-C004-C005-C006-C013-C014-C015-C016-C017	X				10
04019K	CORNER DRIVE GROOVE 15/20 FUTURA	C001-C002-C003-C005-C006-C013-C014-C015-C016-C017	X				10
04026K	FUTURA T/T BOLT TIP	C001-C002-C003-C005-C006-C013-C014-C015-C017	X				10
05311	TILT-AND-TURN WINDOW - ANTI-FALL STRIKER	C001-C002-C004-C005-C006-C013-C014-C015-C016-C017	X				50
05312	TILT-AND-TURN WINDOW - INCORRECT MOVEMENT SAFETY DEVICE STRIKER	C001-C002-C004-C005-C006-C013-C014-C015-C016-C017	X				50
05313	SASH-RAISER	C001-C002-C004-C005-C006-C013-C014-C015-C016-C017	X				50

CLASSIC 3D 80 ARMS

Functions

They enable tilt-and-turn opening in conjunction with the mechanisms and are available in three versions (standard, microventilation and logic).

Materials

Body, fixing block and slider in zamak with GS Silver Plus finish (up to 500 h of corrosion resistance). Rod, connecting bracket, grub screws and screws in stainless steel. Stop disk in polyamide.

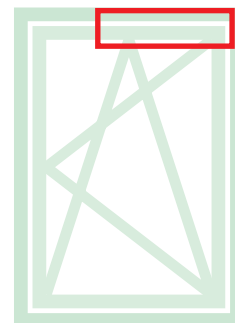

Online data sheet



04329

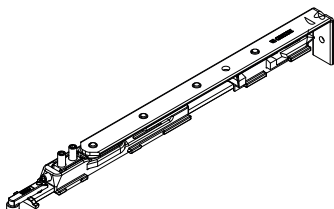

04330

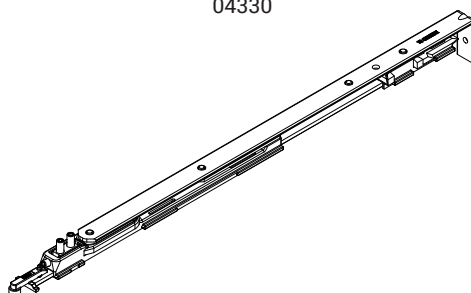

04339

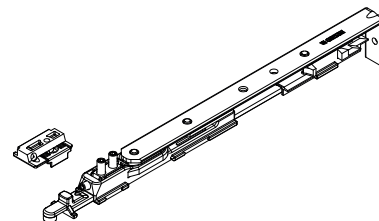

04340

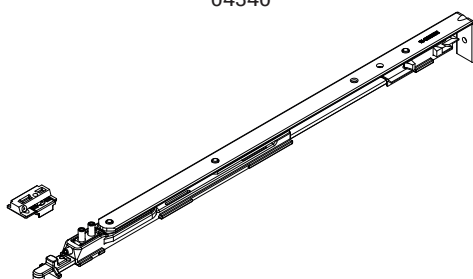

04352

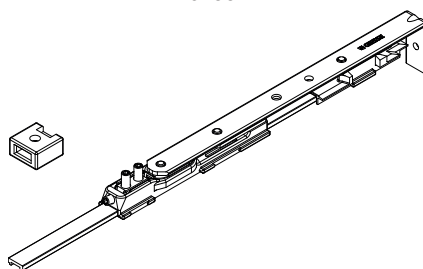

Sash opening

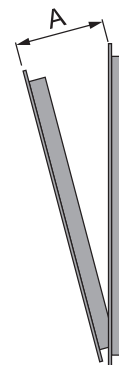

Item code	Description	PROFILE CROSS - SECTION	Range (mm)	Version	A (mm)	Base Raw	Anodised Elox	Painted	Trend/Gold Brass	Pieces per pack
04329	ARM TYPE 1 T/T CLASSIC 3D 80 LOGICA	C001-C002-C003-C005	W 390 ÷ 1300	Logica	110	X				10
04330	ARM TYPE 2 T/T CLASSIC 3D 80 LOGICA	C001-C002-C003-C005	W 550 ÷ 1700	Logica	180	X				10
04339	ARM TYPE 1 T/T CLASSIC 3D 80 MICRO	C001-C002-C003-C005	W 410 ÷ 1300	Micro	110	X				10
04340	ARM TYPE 2 T/T CLASSIC 3D 80 MICRO	C001-C002-C003-C005	W 570 ÷ 1700	Micro	180	X				10
04352	ARM TYPE 0 T/T CLASSIC 80	C001-C002-C003-C005	W 350 ÷ 410	-	110	X				10

CLASSIC 3D 80 ADDITIONAL FASTENING MECHANISMS AND ACCESSORIES

Functions

The additional fasteners make it possible to add further fastening elements that either increase the dimensions of the casement or that can be used when locking points are needed on the cross beams or hinge-side upright.

On the basis of the dimensions of the casement, additional fasteners (for H>1200 mm and W>1000 mm) and the additional arm (which is mandatory for W>1000 mm if the sash weighs more than 60 kg) are to be used in combination with this mechanism.

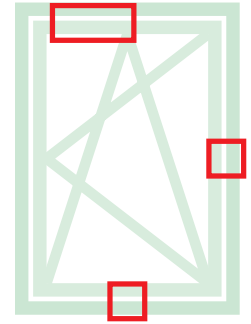

Online data sheet

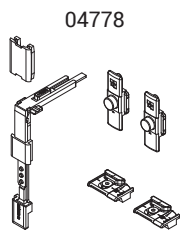
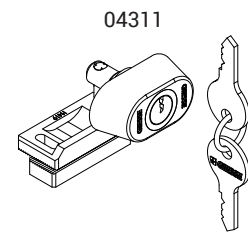
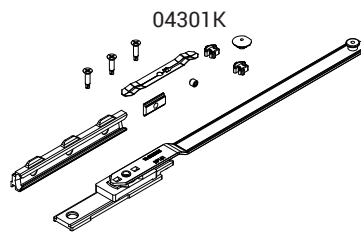
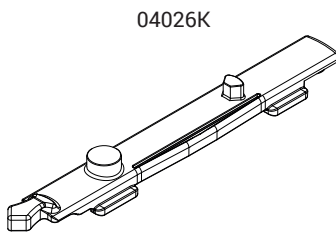
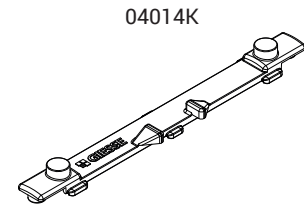
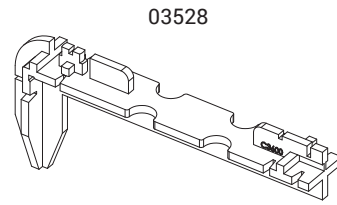
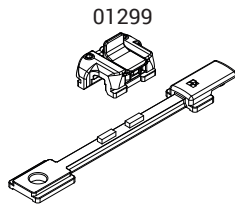

Item code	Description	PROFILE CROSS - SECTION	Range (mm)	Version	Base Raw	Anodised Elox	Painted	Trend/Gold Brass	Pieces per pack
01299	INCORRECT MOVEMENT SAFETY DEVICE	C001-C002-C003-C004-C005-C006-C013-C014-C015-C016-C017	H > 620 HC > 250	-	X				10
03528	TEMPLATE	C001-C002-C003-C004-C005-C006	-	-	X				20
04014K	FUTURA T/T DRIVE ROD	C001-C002-C003-C004-C005-C006-C013-C014-C015-C016-C017	-	-	X				10
04026K	FUTURA T/T BOLT TIP	C001-C002-C003-C005-C006-C013-C014-C015-C017	-	-	X				10
04301K	T/T FUTURA ADDITIONAL ARM	C001-C002-C003-C004-C005-C006	W > 1000	-	X				5
04311	SASH OPENING BLOCK LOCK	C001-C002-C003-C004-C005-C006-C007-C013-C014-C015-C016-C017	-	-	X				10
04778	FUTURA ADDITIONAL FASTENING MECHANISM	C001-C002-C003-C005	H > 1200 L > 1000	-	X				10

CLASSIC 80 SECONDARY SASH

Functions

Adapter for CLASSIC 3D 80 tilt-and-turn secondary sash hinges.
The adapter lets you turn the set of tilt-and-turn hinges into hinges for a secondary sash, keeping the same design, adjustments, dimensions and capacities achievable with a main sash.

Materials

Grub screws and false arm rod made of steel
Support in zamak

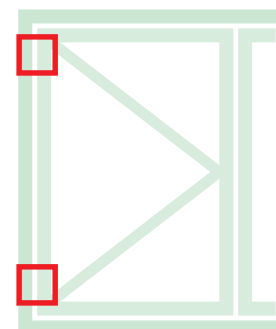

Online data sheet



04727

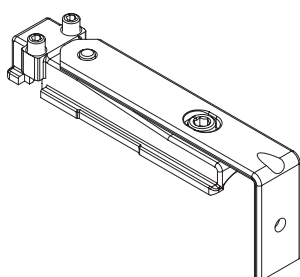

04739

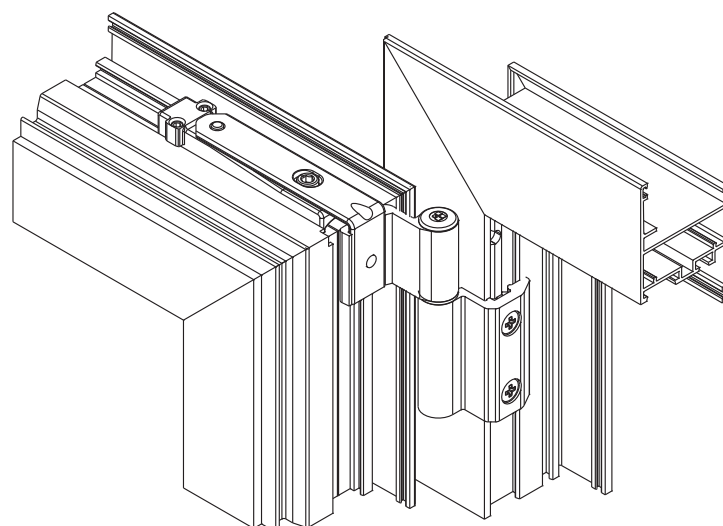
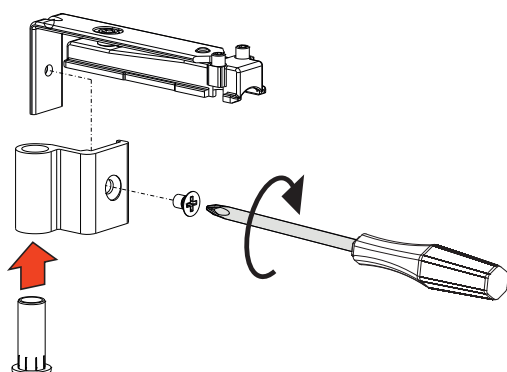
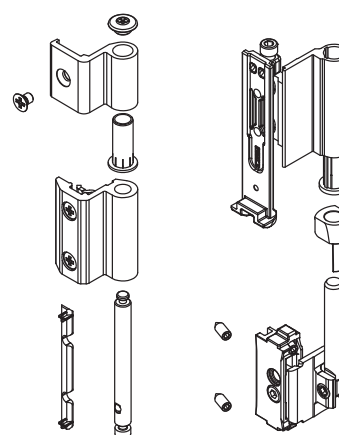

Table of maximum load capacity [kg]

2500	80	80	80	80	80	80	80	80	80	
2400	80	80	80	80	80	80	80	80	80	
2300	80	80	80	80	80	80	80	80	80	
2200	80	80	80	80	80	80	80	80	80	
2100	80	80	80	80	80	80	80	80	80	
2000	80	80	80	80	80	80	80	80	80	
1900	80	80	80	80	80	80	80	80	80	
1800	80	80	80	80	80	80	80	80	80	
1700	80	80	80	80	80	80	80	80	80	
1600	80	80	80	80	80	80	80	80	80	
1500	80	80	80	80	80	80	80	80	80	
1400	80	80	80	80	80	80	80	80	80	
1300	80	80	80	80	80	80	80	80	78	
1200	80	80	80	80	80	80	80	79	73	
1100	80	80	80	80	80	80	73	67		
1000	80	80	80	80	80	73	66			
900	80	80	80	80	73	66				
800	80	80	80	73	65					
700	80	80	73	64						
600	80	80	73	64						
	350	500	600	700	800	900	1000	1100	1200	1300

Table of maximum glass thickness [mm]

2500	25	21	18	16	14	13	11	10	10	
2400	26	22	19	16	15	13	12	11	10	
2300	27	23	19	17	15	14	12	11	10	
2200	29	24	20	18	16	14	13	12	11	
2100	30	25	21	19	17	15	14	12	11	
2000	31	26	22	20	17	16	14	13	12	
1900	33	28	24	21	18	17	15	14	13	
1800	35	29	25	22	19	17	16	15	13	
1700	37	31	26	23	21	18	17	15	14	
1600	39	33	28	25	22	20	18	16	15	
1500	42	35	30	26	23	21	19	17	16	
1400	45	37	32	28	25	22	20	19	17	
1300	48	40	34	30	27	24	22	20	17	
1200	50	44	37	33	29	26	24	20	17	
1100	50	48	41	36	32	29	24	20		
1000	50	50	45	39	35	29	24			
900	50	50	50	44	35	29				
800	50	50	50	45	35					
700	50	50	50	45						
600	50	50	50	45						
	350	500	600	700	800	900	1000	1100	1200	1300

Item code	Description	PROFILE CROSS - SECTION	Base Raw	Anodised Elox	Painted	Trend/Gold Brass	Pieces per pack
04727	CLASSIC 3D 80 SECONDARY SASH ADAPTER	C001	X				10
04739	HINGE T/T CLASSIC 80	C001-C002-C003-C005-C006	X	X	X		10

CONFIGURATION EXAMPLES

CLASSIC 3D 80

Micro configuration with Cremone

MAIN SASH		
Sash width	410 ÷ 1000	1001 ÷ 1300
Hinges	04739	04739
Mechanism	04704	04704
Arm	04339	04339
Additional arm	-	04301K*
Cremone	01039 - 01094	-
SECONDARY SASH		
Hinges	04739	04739
Adapter	04727	04727
Adjustable bolt	02168K	02168K
Striker	01348	01348

* Capacity > 60 kg

Micro configuration with window handle

MAIN SASH		
Sash width	410 ÷ 1000	1001 ÷ 1300
Hinges	04739	04739
Mechanism	0470501	0470501
Arm	04339	04339
Additional arm	-	04301K*
Window handle	02476 - 02415 - 00997	02476 - 02415 - 00997
SECONDARY SASH		
Hinges	04739	04739
Adapter	04727	04727
Adjustable bolt	02168K	02168K
Striker	01348	01348

* Capacity > 60 kg

Micro configuration with NP Supra

MAIN SASH		
Sash width	410 ÷ 1000	1001 ÷ 1300
Hinges	04739	04739
Mechanism	0395501	0395501
Arm	04339	04339
Additional arm	-	04301K*
NP Supra	03962 - 03963	03962 - 03963
SECONDARY SASH		
Hinges	04739	04739
Adapter	04727	04727
Adjustable bolt	02168K	02168K
Striker	01348	01348

* Capacity > 60 kg

Logica configuration with Cremone

MAIN SASH		
Sash width	390 ÷ 1000	1001 ÷ 1300
Hinges	04739	04739
Mechanism	04706N	04706N
Arm	04329	04329
Additional arm	-	04301K*
Cremone	01192 - 01193	-
SECONDARY SASH		
Hinges	04739	04739
Adapter	04727	04727
Adjustable bolt	02168K	02168K
Striker	01348	01348

* Capacity > 60 kg

Logica configuration with window handle

MAIN SASH		
Sash width	390 ÷ 1000	1001 ÷ 1300
Hinges	04739	04739
Mechanism	0470701	0470701
Arm	04329	04329
Additional arm	-	04301K*
Window handle	02486	02486
SECONDARY SASH		
Hinges	04739	04739
Adapter	04727	04727
Adjustable bolt	02168K	02168K
Striker	01348	01348

* Capacity > 60 kg

GS990

ADJUSTMENTS [mm]

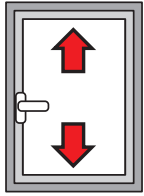

Height:
+1.5 / -0.5

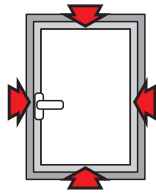

Striker compression:
±0,9

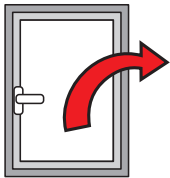

Sash fall:
+3.5 / -1.5

GS990

Functions

Complete system for the construction of GS990 tilt-and-turn windows.

Technical Features

The GS990 tilt-and-turn window is composed of:

- T/T GS990 STANDARD FASTENING MECHANISMS
- ARMS, available in two versions depending on the width of the sash
- Cremona or window handle (available in various models)

Adjustments

The adjustments are micrometric and independent.

Graph of sizes and load capacities for art.: 04507, 04529

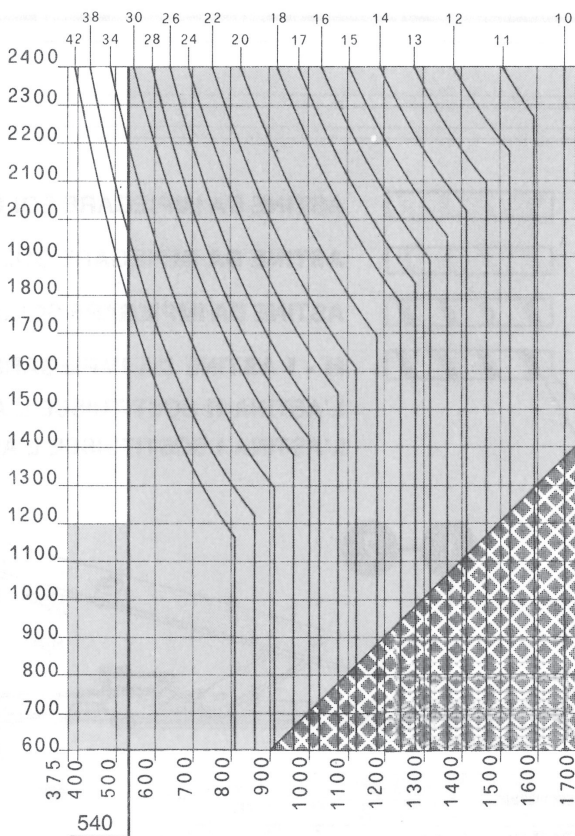

Graph of sizes and load capacities for art.: 04516, 04518

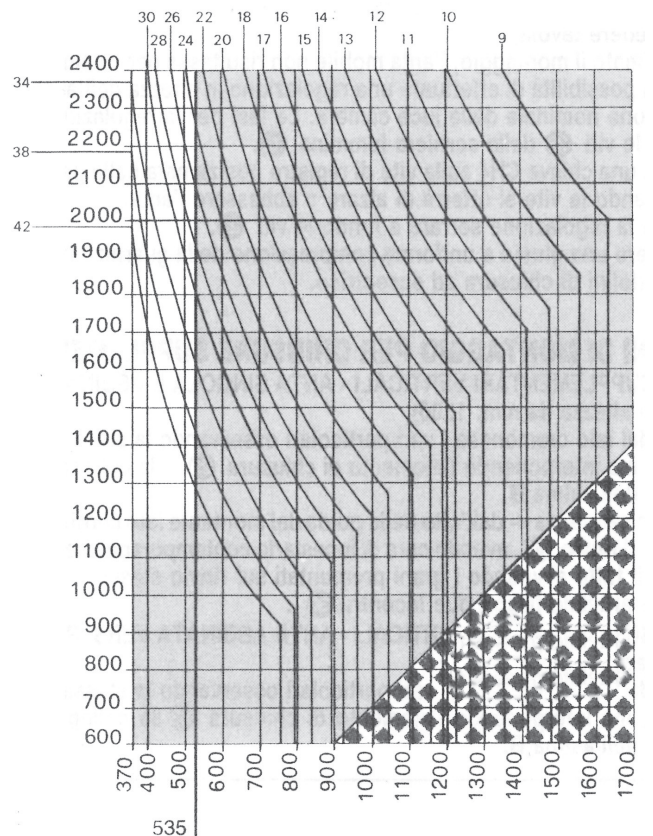

GS990

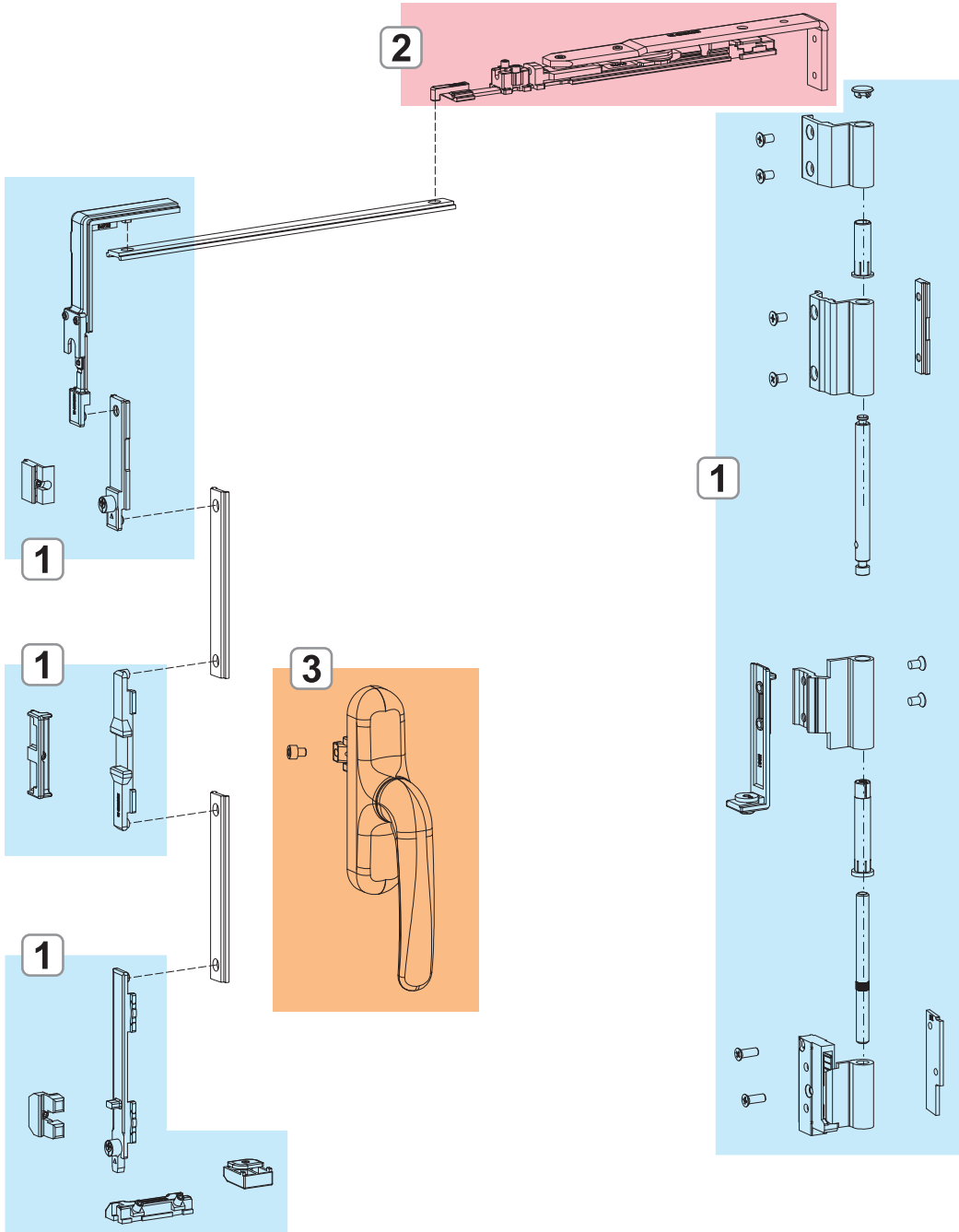

- 1. GS990 BASIC MECHANISM
- 2. GS990 ARMS
- 3. CREMONES

GS990 BASIC MECHANISM

Functions

Complete system for the construction of GS990 tilt-and-turn windows

Technical Features

Mechanisms including hinges and hardware: available in various finishes. The hinges are supplied completely pre-assembled and ready to be installed on the profile, the hardware consists of ready-assembled accessories that make installation easy and instant

Materials: Hinges

Body of hinges in extruded aluminium and zamak supports. Pins, screws and grub screws in stainless steel.

Materials: Mechanism

Drive, drive rod, mechanism bolt tip and strikers in zamak. Screws and grub screws in stainless steel. Polyamide raiser.

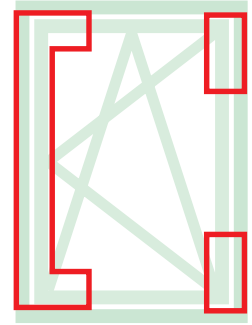

Online data sheet

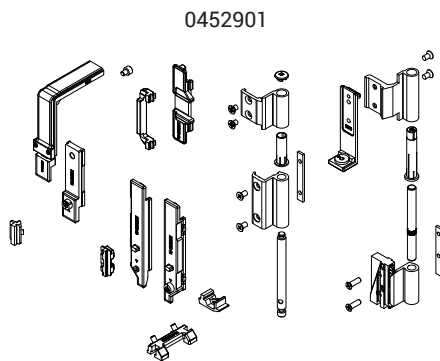
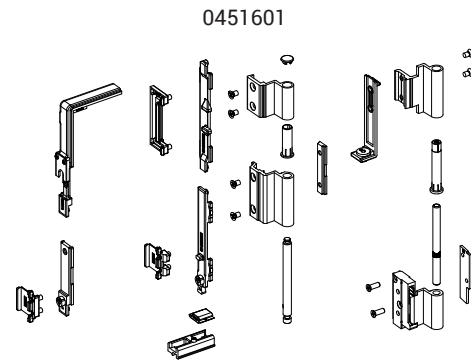
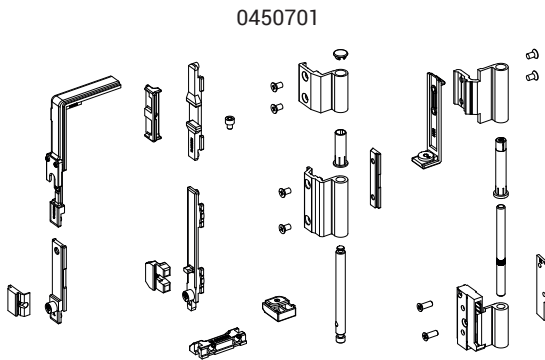

Item code	Description	PROFILE CROSS - SECTION	Mechanism	Base Raw	Anodised Elox	Painted	Trend/Gold Brass	Pieces per pack
0450701	AR GS990 BASIC MECHANISM	C009	Cremona	X	X	X	X	5
0451601	AR GS990 BASIC MECHANISM	C010	Cremona		X	X	X	5
0452901	AR GS990 BASIC MECHANISM	C008	Cremona	X	X	X	X	5

GS990 ARMS

Functions

Complete system for the construction of GS990 tilt-and-turn windows

Technical Features

Mechanisms including hinges and hardware: available in various finishes. The hinges are supplied completely pre-assembled and ready to be installed on the profile, the hardware consists of ready-assembled accessories that make installation easy and instant

Materials

Body, fixing block and slider in zamak, mechanism rod in aluminium.
 Arm rod, connecting bracket, grub screws and screws in stainless steel.
 Stop disk in polyamide.

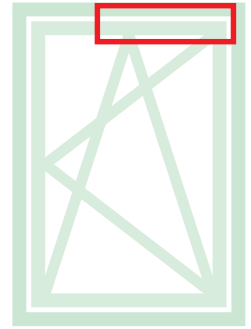

Online data sheet

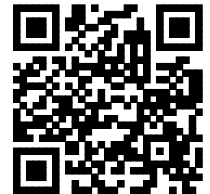

ARM T1 GS990

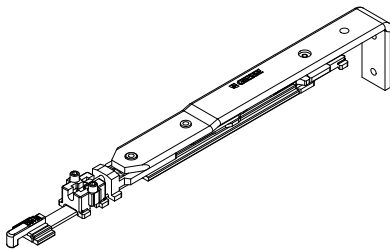

ARM T2 GS990

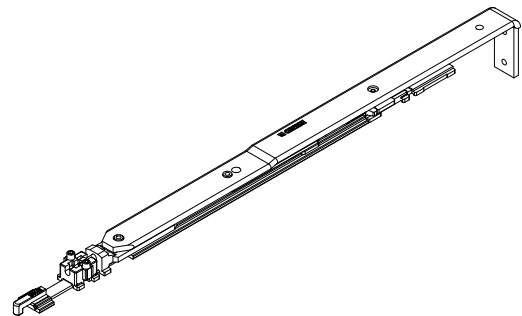

Item code	Description	PROFILE CROSS - SECTION	Range (mm)	Base Raw	Anodised Elox	Painted	Trend/Gold Brass	Pieces per pack
0421101	ARM T1 GS990	C001-C002-C005-C006-C010-C011-C013-C014-C015-C017	W 370 ÷ 535	X				5
0421701	ARM T1 GS990	C009	W 375 ÷ 540	X				5
0422301	ARM T2 GS990	C001-C010-C011-C015	W 536 ÷ 1700	X				5
0422701	ARM T2 GS990	C009	W 541 ÷ 1700	X				5

GS990 ADDITIONAL FASTENING MECHANISMS AND ACCESSORIES

Functions

Arm that allows the bottom-hung opening in combination with the GS990 tilt-and-turn mechanisms.

Technical Features

They enable tilt-and-turn opening in conjunction with the mechanisms and are available in two versions depending on the width of the sash.

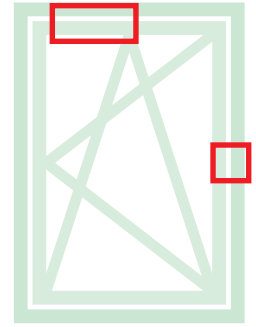

Online data sheet



0424001

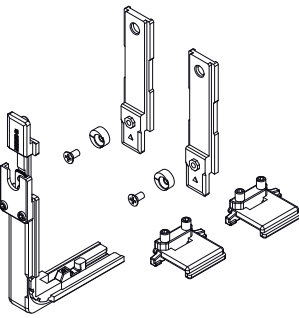

0424101

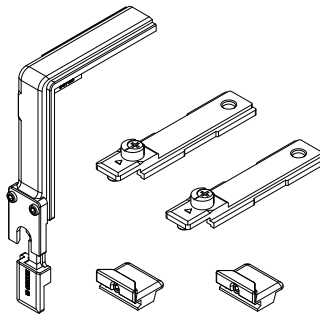

0424601

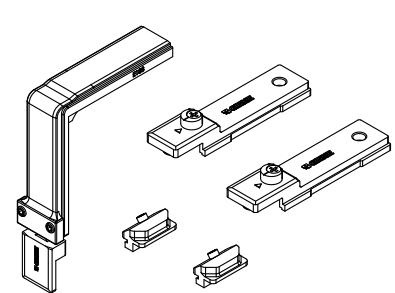

0424701

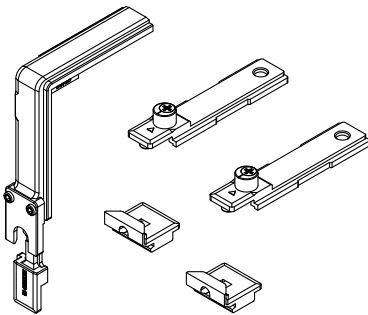

0430601

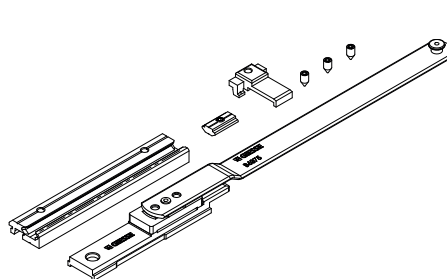

Item code	Description	PROFILE CROSS - SECTION	Range (mm)	Base Raw	Anodised Elox	Painted	Trend/Gold Brass	Pieces per pack
0424001	VERTICAL ADDITIONAL FASTENING MECHANISM GS990	C010	H > 1200	X				10
0424101	VERTICAL ADDITIONAL FASTENING MECHANISM GS990	C001-C002-C011-C013-C014-C015-C017	H > 1200	X				10
0424601	VERTICAL ADDITIONAL FASTENING MECHANISM GS990	C008	H > 1200	X				10
0424701	VERTICAL ADDITIONAL FASTENING MECHANISM GS990	C009	H > 1200	X				10
0430601	ADDITIONAL ARM	C008	W > 1000	X				5

CONFIGURATION EXAMPLES

GS990

Basic configuration with Cremone
(profile cross-sections type 8 and 9)

MAIN SASH		
Sash width	375 ÷ 540	541 ÷ 1700
Mechanism	0452901 - 0450701	0452901 - 0450701
Arm	0421701	0422701
Additional arm	-	0430601 - 0430701
Cremone	01039 - 01090K	01039 - 01090K

Basic configuration with window handle
(profile cross-section type 11)

MAIN SASH		
Sash width	370 ÷ 535	536 ÷ 1700
Mechanism	0451801	0451801
Arm	0421101	0422301
Additional arm	-	04301K
Window handle	02476 - 02415 - 00997	02476 - 02415 - 00997

Basic configuration with Cremone
(profile cross-section type 10)

MAIN SASH		
Sash width	370 ÷ 535	536 ÷ 1700
Mechanism	0451601	0451601
Arm	0421101	0422301
Additional arm	-	04301K
Cremone	01039 - 01090K	01039 - 01090K



**ACCESSORIES
AND
FASTENING
MECHANISMS
FOR SLIDERS**



ADJUSTABLE CARRERA 1 PULLEYS

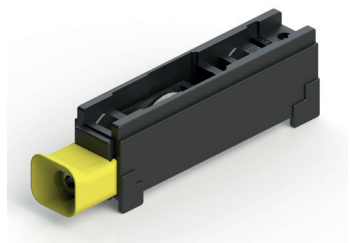

Functions

Adjustable pulley with one wheel for doors and windows in aluminium.

Online data sheet



Technical Features

The pulley is fixed with a clamping grub screw, without requiring specific machining.
 Micrometrically adjustable, it enables moving the sash vertically in an overall range of on average 4 mm (see adjustment column in the table).
 Adjustment is easy since the adjustment screw is located inside the yellow centring element which facilitates insertion of the key. The adjustment can also be made with the sash already mounted and installed.
 The wheels are mounted on ball bearings or needle bearings depending on the model and can be removed together with the support without having to disassemble the pulley.
 The wheels with bearings are shielded to keep the grease inside them.

Materials

External support in grey polyamide
 Yellow polyamide centring element
 Wheel internal support in Silver Plus zamak or polyamide depending on the version (see table)
 Wheel with bearing in steel and neutral reinforced polyamide cover
 Mounting grub screw and adjustment screw in stainless steel

Capacities

see table

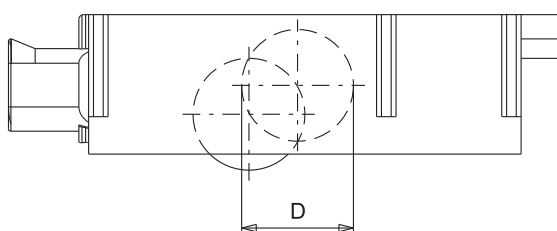
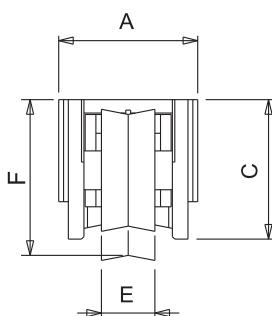
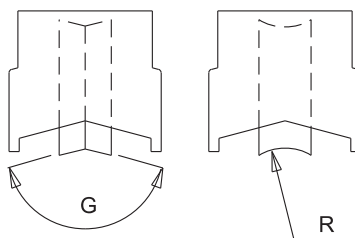
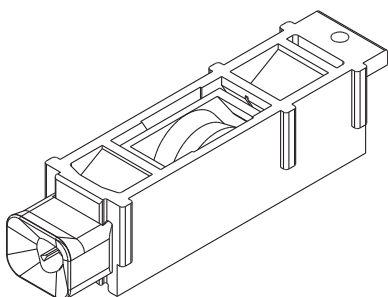

ADJUSTABLE PULLEYS

Item code	Description	Note	Pulley Load Capacity (kg)	A [mm]	C [mm]	D [mm]	E [mm]	F [mm]	Adjustment [mm]	G [°] R [mm]	Bearing type	External support	Internal support	Base Raw	Anodised Elox	Painted	Trend/Gold Brass	Pieces per pack
02914	CARRERA 1 ADJUSTABLE PULLEY	Bulk packaging	40	25,5	26,1	27	11	29,7	+2.5/-2.5	5 mm	Balls	Polyamide	Zamak	X				100
03104	CARRERA 1 ADJUSTABLE PULLEY	Bulk packaging	45	27,4	23,4	19	8	26,6	+2,6/-2,3	150°	Balls	Polyamide	Zamak	X				100
03146N	CARRERA 1 ADJUSTABLE PULLEY	Bulk packaging	55	28	30	28,8	12	32	+2.4/-3.4	156°	Balls	Polyamide	Zamak	X				200
03147N	CARRERA 1 ADJUSTABLE PULLEY	Bulk packaging	55	28	30	27,3	11	30,2	+2.2/-2.8	10.1 mm	Balls	Polyamide	Zamak	X				200
03148N	CARRERA 1 ADJUSTABLE PULLEY	Bulk packaging	45	24,5	23,6	21,7	9	26,9	+4.7/-2.1	150°	Balls	Polyamide	Zamak	X				200
03290	CARRERA 1 ADJUSTABLE PULLEY	Bulk packaging	45	22,7	25,8	20,4	8	24,6	+2.7/-2.1	150°	Roller	Polyamide	Zamak	X				40
03297	CARRERA 1 ADJUSTABLE PULLEY	Bulk packaging	25	28	30	28,6	11	32	+2.4/-3.4	156°	Balls	Polyamide	Zamak	X				200
03398	CARRERA 1 ADJUSTABLE PULLEY	Bulk packaging	45	22,7	25,8	19	8	23,7	+2.7/-2.1	150°	Balls	Polyamide	Zamak	X				100
03473	CARRERA 1 ADJUSTABLE PULLEY	Bulk packaging	55	27,7	30	26	11	30,6	+3.3/-2.5	4 mm	Balls	Polyamide	Zamak	X				200
04560	CARRERA 1 ADJUSTABLE PULLEY	Bulk packaging	45	22,7	25	19	8	24,5	+/- 2.3	150°	Balls	Polyamide	Zamak	X				100
06504	CARRERA 1 ADJUSTABLE PULLEY	Bulk packaging	40	22,2	23	19	8	23	+2.1/-2.7	5 mm	Balls	Polyamide	Zamak	X				100
06955	CARRERA 1 ADJUSTABLE PULLEY	Bulk packaging	45	22,7	25,8	19	8	24,6	+2.7/-2.1	150°	Balls	Polyamide	Zamak	X				40
00806	CARRERA 1 ADJUSTABLE PULLEY	Set of 4 pcs.	45	22,7	25,8	19	8	23,7	+2.7/-2.1	150°	Balls	Polyamide	Zamak	X				16
03178	CARRERA 1 ADJUSTABLE PULLEY	Set of 4 pcs.	45	22,7	25	19	8	24,5	+/- 2.3	150°	Balls	Polyamide	Zamak	X				50

ADJUSTABLE CARRERA 2 PULLEYS

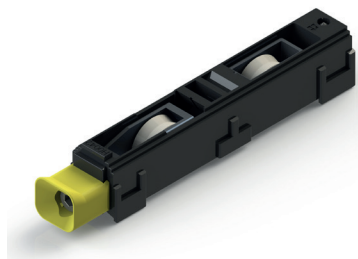

Functions

Adjustable pulley with two wheels for doors and windows in aluminium.

Online data sheet



Technical Features

The pulley is fixed with a clamping grub screw, without requiring specific machining.

Micrometrically adjustable, it enables moving the sash vertically in an overall range of on average 4 mm (see adjustment column in the table).

Adjustment is easy since the adjustment screw is located inside the yellow centring element which facilitates insertion of the key. The adjustment can also be made with the sash already mounted and installed.

The wheels are normally mounted on ball bearings or needle bearings depending on the model and can be removed together with the support without having to disassemble the pulley.

The wheels with bearings are shielded to keep the grease inside them.

Materials

Support in grey polyamide

Yellow polyamide centring element

Wheel support in Silver Plus zamak

Wheel with bearing in steel and neutral reinforced polyamide cover

Mounting grub screw and adjustment screw in stainless steel

Capacities

see table

Pulley fixing

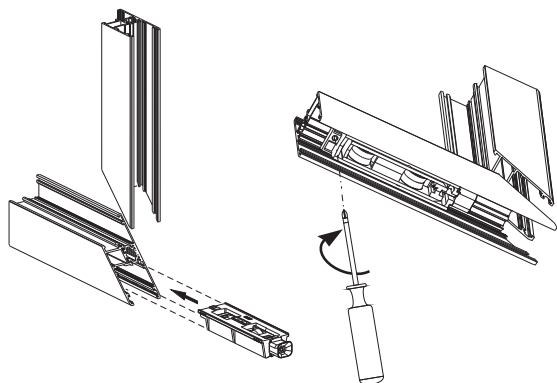

Wheel replacement

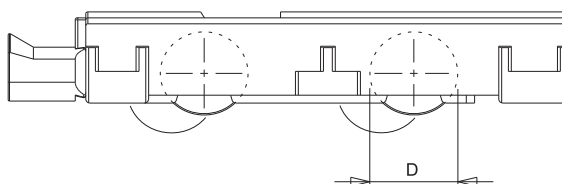
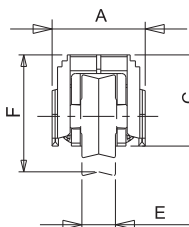
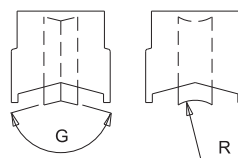
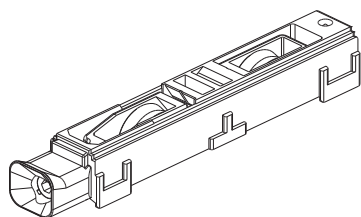
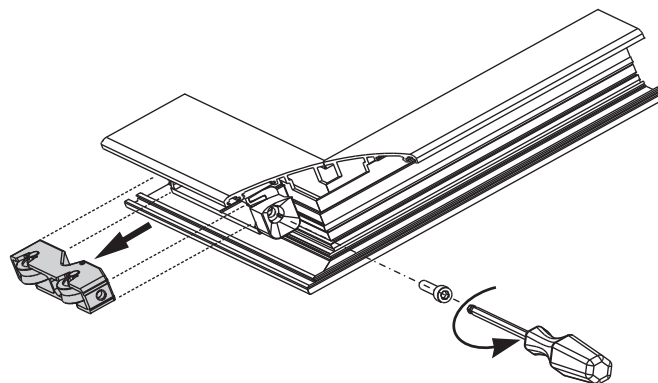

ADJUSTABLE PULLEYS

Item code	Description	Note	Pulley Load Capacity [kg]	A [mm]	C [mm]	D [mm]	E [mm]	F [mm]	Adjustment [mm]	G [°] R [mm]	Bearing type	External support	Internal support	Base Raw	Anodised Elox	Painted	Trend/Gold Brass	Pieces per pack
03105	CARRERA 2 ADJUSTABLE PULLEY	Bulk packaging	90	27,4	23,6	19	8	26,6	+2,6/-2,3	150°	Balls	Polyamide	Zamak	X				100
03136N	CARRERA 2 ADJUSTABLE PULLEY	Bulk packaging	110	28	30	28,8	12	31,3	+2,6/-2,8	156°	Balls	Polyamide	Zamak	X				200
03137N	CARRERA 2 ADJUSTABLE PULLEY	Bulk packaging	110	28	30	27,3	11	29,4	+3,3/-1,7	10,1 mm	Balls	Polyamide	Zamak	X				200
03141N	CARRERA 2 ADJUSTABLE PULLEY	Bulk packaging	90	24,5	23,6	21,7	9	27	+2,3/-3	150°	Balls	Polyamide	Zamak	X				200
03291	CARRERA 2 ADJUSTABLE PULLEY	Bulk packaging	90	22,7	25,8	19	8	24,6	+2,8/-2,1	150°	Roller	Polyamide	Zamak	X				40
03298	CARRERA 2 ADJUSTABLE PULLEY	Bulk packaging	50	17,7	30	27	11	31,3	+2,6/-2,8	156°	Balls	Polyamide	Zamak	X				200
03390	CARRERA 2 ADJUSTABLE PULLEY	Bulk packaging	90	27,7	22,4	19,2	9	26,3	+2,6/-2,2	120°	Balls	Polyamide	Zamak	X				100
03397	CARRERA 2 ADJUSTABLE PULLEY	Bulk packaging	90	19	23,2	19	8	23,7	+1,4/-2,3	150°	Balls	Polyamide	Zamak	X				100
03471	CARRERA 2 ADJUSTABLE PULLEY	Bulk packaging	90	36	28,7	24,4	11	28,5	+2,9/-2,5	158°	Balls	Polyamide	Zamak	X				200
03472	CARRERA 2 ADJUSTABLE PULLEY	Bulk packaging	110	27,7	30	26	11	29	+3,5/-1	4 mm	Balls	Polyamide	Zamak	X				200
03534	CARRERA 2 ADJUSTABLE PULLEY	Bulk packaging	60	31,5	22	22,5	9	25,3	+2,5/-2,5	2,6 mm	Balls	Polyamide	Zamak	X				100
03557	CARRERA 2 ADJUSTABLE PULLEY	Bulk packaging	110	31,5	23,2	20	9	26,3	+2,3/-3	160°	Balls	Polyamide	Zamak	X				50
04542	CARRERA 2 ADJUSTABLE PULLEY	Bulk packaging	90	22,2	21	19	8	21,5	+3,5/-1	150°	Balls	Polyamide	Zamak	X				100
04546	CARRERA 2 ADJUSTABLE PULLEY	Bulk packaging	90	22,2	23	19	8	22,5	+2,6/-2,2	150°	Balls	Polyamide	Zamak	X				100
04549	CARRERA 2 ADJUSTABLE PULLEY	Bulk packaging	110	28,5	23,2	20	9	26,3	+2,3/-3	156°	Balls	Polyamide	Zamak	X				100
04563	CARRERA 2 ADJUSTABLE PULLEY	Bulk packaging	90	28,5	23,2	20	9	25,6	+2,6/-2,4	150°	Balls	Polyamide	Zamak	X				100
04572	CARRERA 2 ADJUSTABLE PULLEY	Bulk packaging	70	24,6	32	18,4	8	30,5	+2,5/-2,2	140°	Balls	Polyamide	Zamak	X				100
04600	CARRERA 2 ADJUSTABLE PULLEY	Bulk packaging	90	38,2	19,5	20	9	25	+3,5/-1,7	156°	Balls	Polyamide	Zamak	X				100
06512	CARRERA 2 ADJUSTABLE PULLEY	Bulk packaging	80	22,2	23	19	8	19,3	+2,1/-2,7	2,6 mm	Balls	Polyamide	Zamak	X				100
00801	CARRERA 2 ADJUSTABLE PULLEY	Set of 4 pcs.	90	19	23,2	19	8	27,7	+1,4/-2,3	150°	Balls	Polyamide	Zamak	X				22
02985	CARRERA 2 ADJUSTABLE PULLEY	Set of 4 pcs.	90	22,2	21	18	12	22	+2,6/-2,2	120°	Balls	Polyamide	Zamak	X				50
03116	CARRERA 2 ADJUSTABLE PULLEY	Set of 4 pcs.	110	31,5	23,2	20	9	26,3	+2,3/-2,9	156°	Balls	Polyamide	Zamak	X				50
03118	CARRERA 2 ADJUSTABLE PULLEY	Set of 4 pcs.	110	28,5	23,2	20	9	26,3	+2,3/-2,9	156°	Balls	Polyamide	Zamak	X				50
03120	CARRERA 2 ADJUSTABLE PULLEY	Set of 4 pcs.	90	22,2	21	19	8	21,5	+3,5/-1	150°	Balls	Polyamide	Zamak	X				50
03125	CARRERA 2 ADJUSTABLE PULLEY	Set of 4 pcs.	90	22,2	23	19	8	22,5	+2,6/-2,2	150°	Balls	Polyamide	Zamak	X				50
03133	CARRERA 2 ADJUSTABLE PULLEY	Set of 4 pcs.	110	28,5	23,2	20	9	26,3	+2,3/-3	156°	Balls	Polyamide	Zamak	X				50
03139	CARRERA 2 ADJUSTABLE PULLEY	Set of 4 pcs.	90	22,2	23	19	8	22,5	+2,6/-2,2	150°	Balls	Polyamide	Zamak	X				50
03183	CARRERA 2 ADJUSTABLE PULLEY	Set of 4 pcs.	90	37,8	22	19	12	23,3	+3/-1,3	160°	Roller	Polyamide	Polyamide	X				20
03289	CARRERA 2 ADJUSTABLE PULLEY	Set of 4 pcs.	90	29,4	22,5	19	12	22,5	+2,5/-1,5	150°	Roller	Polyamide	Polyamide	X				50
06503	CARRERA 2 ADJUSTABLE PULLEY	Set of 4 pcs.	80	22,2	23	19	8	23	+2,1/-2,7	5 mm	Balls	Polyamide	Zamak	X				50

ADJUSTABLE PULLEYS 1 WHEEL

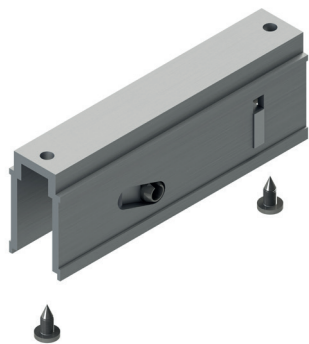

Functions

Adjustable pulley with one wheel for doors and windows in aluminium.

Online data sheet



Technical Features

The pulley is fixed with a clamping grub screw, without requiring specific machining.

Micrometrically adjustable, it enables moving the sash vertically in an overall range of approximately 4 mm (depends on the model).

The adjustment can also be made with the sash already mounted and installed.

The wheel is mounted on ball bearings and can be removed together with its support without having to disassemble the pulley.

Materials

Support in grey polyamide

Wheel support in Silver Plus zamak

Wheel with bearing in steel and neutral reinforced polyamide cover

Mounting grub screw and adjustment screw in stainless steel

Capacities

40 kg with two pulleys

00859

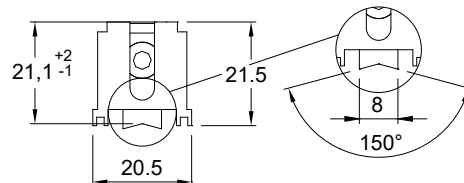
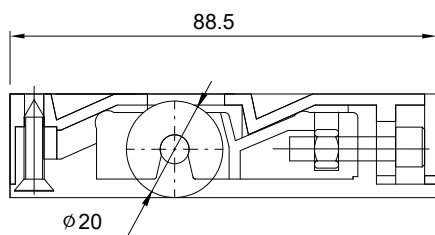
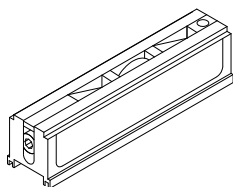

03122

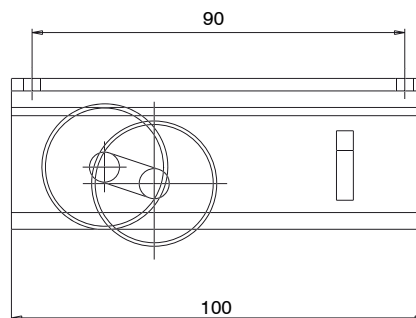
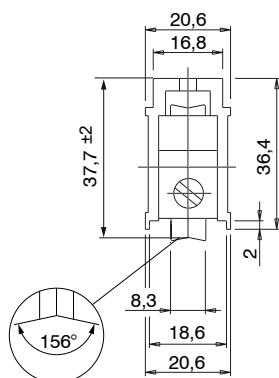
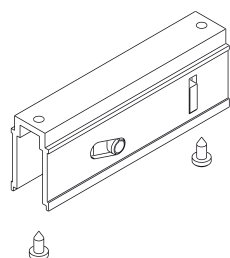

Item code	Description	Note	Pulley Load Capacity [kg]	Adjustment [mm]	Base Raw	Anodised Elox	Painted	Trend/Gold Brass	Pieces per pack
00859	ADJUSTABLE 1 WHEEL PULLEY	set of 4 pieces	20	+2 / -1	X				16
03122	ADJUSTABLE 1 WHEEL PULLEY	set of 4 pieces	35	± 2	X				40

ADJUSTABLE PULLEYS 2 WHEELS

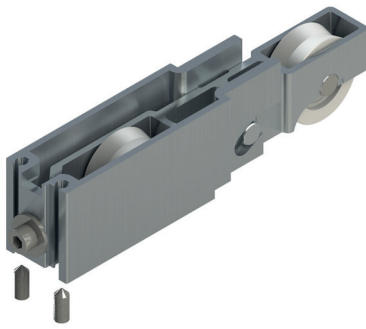

Functions

Adjustable pulley, with two wheels, for windows and sliding doors in aluminium.

Online data sheet



Technical Features

The pulley is micro-adjustable and allows vertical movement of the sash through a range of 4 mm (0315202) or of 8 mm (07195). Its special feature is that it can be inspected without having to disassemble the sash, by screwing in the adjustment screw. The wheels are mounted on ball bearings.

Materials

Art. 0315202: support in extruded aluminium
 Art. 07195: support in steel (AISI 304)
 Wheels with bearing in steel and reinforced polyamide cover
 Self-braking plug in fibreglass reinforced polyamide
 Screws and grub screws in stainless steel

Capacities

See table

0315202

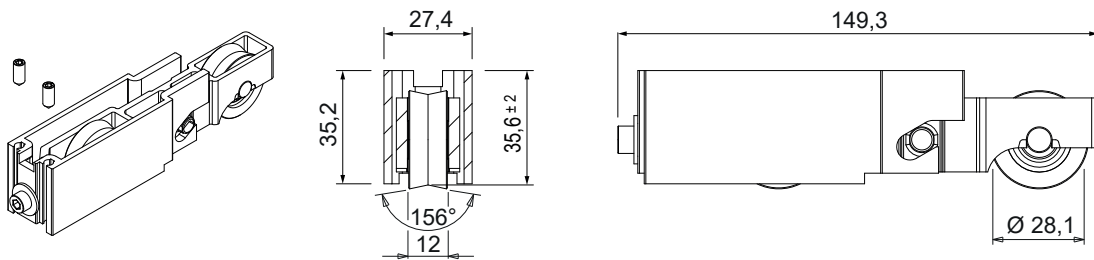

07195

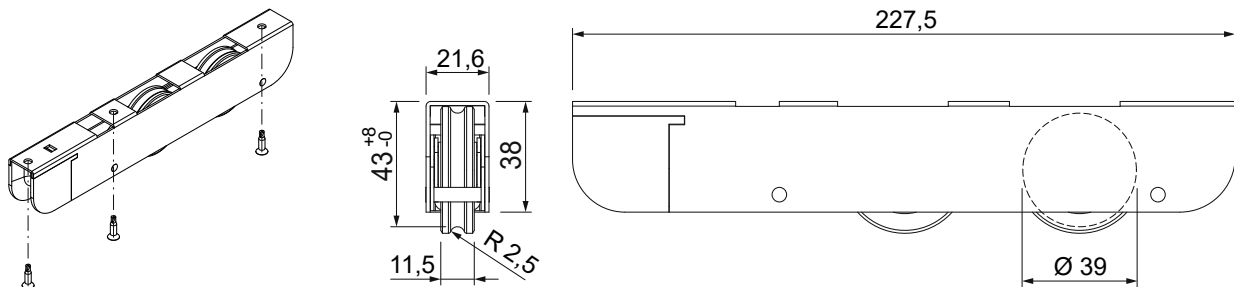

Item code	Description	Note	Pulley Load Capacity [kg]	Adjustment [mm]	Base Raw	Anodised Elox	Painted	Trend/Gold Brass	Pieces per pack
0315202	2-WHEEL ADJUSTABLE PULLEY	set of 4 pieces	120	± 2	X				10
07195	2-WHEEL ADJUSTABLE PULLEY	Bulk packaging	100	+ 8 / - 0	X				10

ADJUSTABLE PULLEYS 4 WHEELS

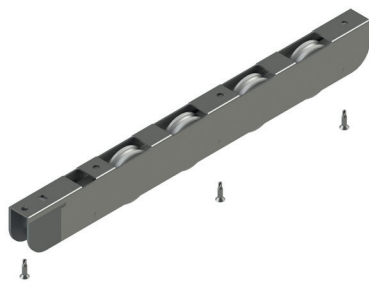

Functions

Adjustable pulley, with four wheels, for windows and sliding doors in aluminium.

Online data sheet



Technical Features

The pulley is micro-adjustable and allows vertical movement of the sash through a range of 8 mm. Its special feature is that it can be inspected without having to disassemble the sash, by screwing in the adjustment screw. The wheels are mounted on ball bearings.

Materials

Support in steel (AISI 304)
Wheels with bearing in steel and reinforced polyamide cover
Stroke adjustment block in steel
Screws and grub screws in stainless steel

Capacities

kg 300 with 2 pulleys

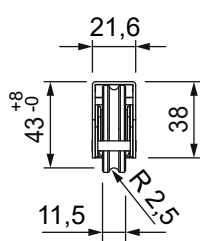
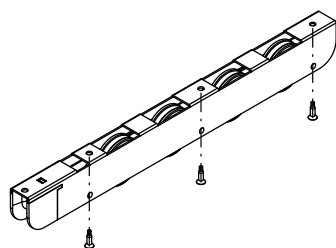

07196

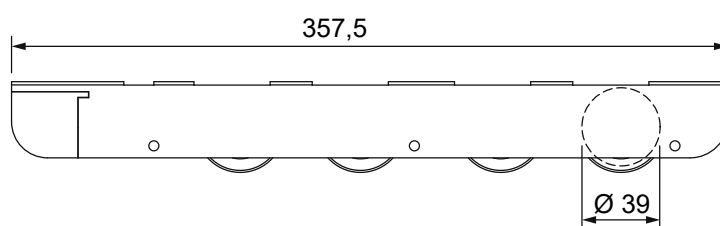

Item code	Description	Note	Pulley Load Capacity [kg]	Adjustment [mm]	Base Raw	Anodised Elox	Painted	Trend/Gold Brass	Pieces per pack
07196	4-WHEEL ADJUSTABLE PULLEY	Bulk packaging	150	+ 8 / - 0	X				10

FIXED CARRERA 1 PULLEYS

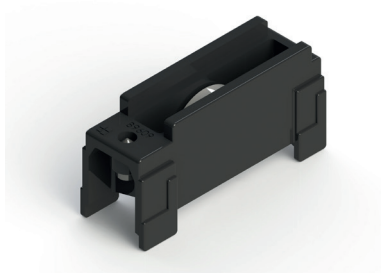
**Functions**

Fixed pulley with one wheel for doors and windows in aluminium.

[Online data sheet](#)

**Technical Features**

The pulley is fixed with a clamping grub screw, without requiring specific machining.

The pulley does not allow micrometric adjustment of the sash. It is in any case possible to vary the position of the wheel with a range that on average varies from +1 to -1 mm (in fixed positions). This adjustment is achieved by moving the wheel into different locations inside the pulley body.

The wheels are normally mounted on ball bearings or needle bearings depending on the model and can be removed without having to disassemble the pulley.

The wheels with bearings are shielded to keep the grease inside them.

Materials

Support in grey polyamide
Wheel with bearing or rollers in steel and neutral reinforced polyamide cover.

Stainless steel mounting grub screw

Capacities

see table

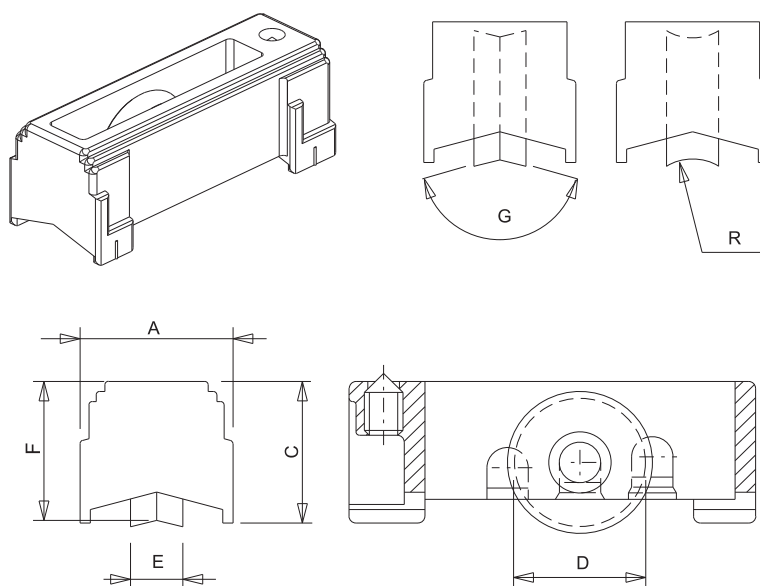

FIXED PULLEYS

Item code	Description	Note	Load capacity (kg)	A [mm]	C [mm]	D [mm]	E [mm]	F [mm]	Adjustment [mm]	G [°]	Bearing	External support	Base Raw	Anodised Elox	Painted	Trend/Gold Brass	Pieces per pack
03319	FIXED CARRERA 1 PULLEY	Bulk packaging	45	15,9	21	19	8	21,9	+1/-1	150°	Ball	Polyamide with fiberglass	X				100
04545	FIXED CARRERA 1 PULLEY	Bulk packaging	45	22,7	23	19	8	22,5	+0.8/-0.8	150°	Ball	Polyamide with fiberglass	X				100
04561	FIXED CARRERA 1 PULLEY	Bulk packaging	45	28,5	23	20	9	26,3	+2/-1	150°	Ball	Polyamide with fiberglass	X				100
03079	FIXED CARRERA 1 PULLEY	Set of 4 pcs.	45	25	21	20	11,5	24,7	+1/-1	150°	Ball	Polyamide with fiberglass	X				200
03115	FIXED CARRERA 1 PULLEY	Set of 4 pcs.	55	31,5	23	20	9	26,3	+2/-1	156°	Ball	Polyamide with fiberglass	X				50
03119X	FIXED CARRERA 1 PULLEY	Set of 4 pcs.	45	22,5	21,1	19	8	21,5	+0.8/-0.8	150°	Ball	Polyamide with fiberglass	X				50
03123	FIXED CARRERA 1 PULLEY	Set of 4 pcs.	45	22,7	23	19	8	22,5	+0.8/-0.8	150°	Ball	Polyamide with fiberglass	X				50
03132	FIXED CARRERA 1 PULLEY	Set of 4 pcs.	45	28,5	23	20	9	26,3	+2/-1	156°	Ball	Polyamide with fiberglass	X				50
03138	FIXED CARRERA 1 PULLEY	Set of 4 pcs.	45	22,8	23	19	8	22,5	+/-0,8	150°	Ball	Polyamide with fiberglass	X				50

FIXED CARRERA 2 PULLEYS

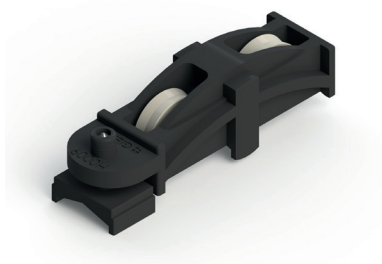

Functions

Fixed pulley with two wheels for doors and windows in aluminium.

Online data sheet



Technical Features

The pulley is fixed with a clamping grub screw, without requiring specific machining.
The wheels are mounted on ball bearings and are shielded to keep the grease inside them.

Materials

Support in grey polyamide.
Wheels with bearing in steel and neutral reinforced polyamide cover.
Stainless steel mounting grubscrew.

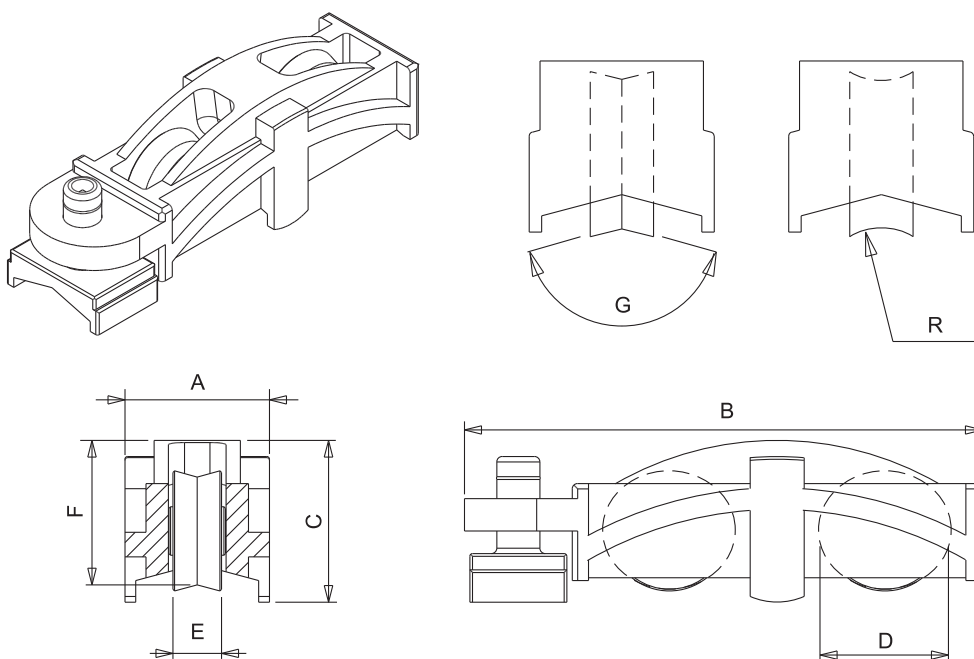

Item code	Description	Note	Load capacity (kg)	A [mm]	C [mm]	D [mm]	E [mm]	F [mm]	G [°]	Bearing	External support	Internal support	Base Raw	Anodised Elox	Painted	Trend/Gold Brass	Pieces per pack
04559	CARRERA 2 FIXED PULLEY	Bulk packaging	90	26,8	30	19	9	26.8 (pivoting)	150°	Balls	Polyamide	-	X				100
06954	CARRERA 2 FIXED PULLEY	Bulk packaging	90	23	25,8	20	8	-	150°	Balls	Polyamide	zamac	X				40

FIXED PULLEYS 1 WHEEL



Functions

Pulley in extruded aluminium with one wheel for windows or sliding doors in aluminium.

Online data sheet



Technical Features

The wheel is mounted on a ball bearing. Its special feature is that it can be inspected without having to disassemble the sash, by removing the fixing screws.

03529

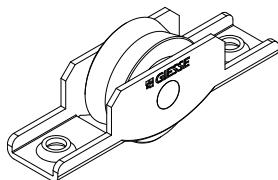

03539

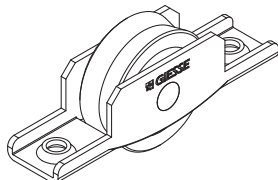

03558

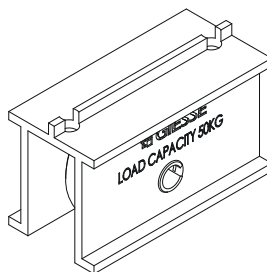

03151N

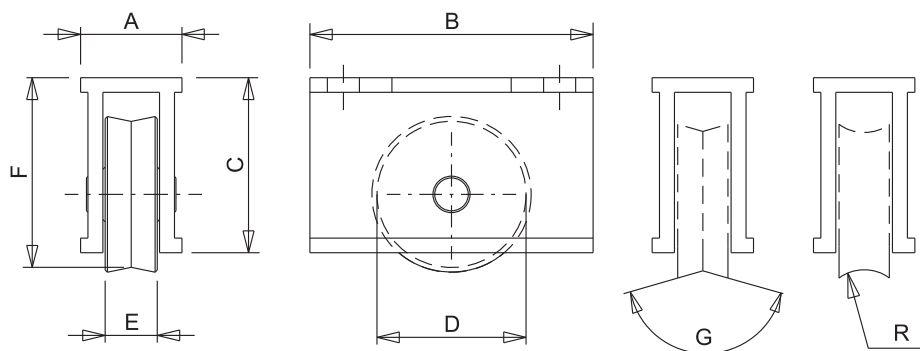
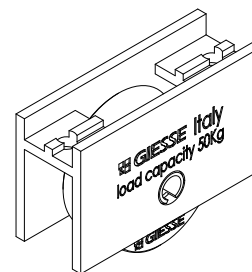

Item code	Description	Note	Load capacity (kg)	A [mm]	B [mm]	C [mm]	D [mm]	E [mm]	F [mm]	G [°]	Bearing	External support	Base Raw	Anodised Elox	Painted	Trend/Gold Brass	Pieces per pack
03529	FIXED PULLEY 1 WHEEL	Bulk packaging	50	16	70	15,6	24	11	/	156°	Balls	Steel	X				200
03539	FIXED PULLEY 1 WHEEL	Bulk packaging	50	16	70	18	28	11	-	156°	Balls	Steel	X				200
03558	FIXED PULLEY 1 WHEEL	Bulk packaging	60	24	50	30,4	28	12	34,85	156°	Balls	Aluminium	X				200
03151N	FIXED PULLEY 1 WHEEL	Set of 4 pcs.	50	17,8	50	29,2	28	12	35,25	156°	Balls	Aluminium	X				100

FIXED PULLEYS 2 WHEELS

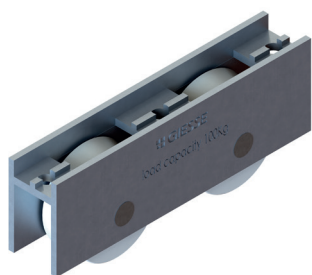

Functions

Fixed double-wheel pulleys for aluminium sliding doors and windows.

Online data sheet



Technical Features

The pulley can be removed without disassembling the sash.
It is fixed with 2 self-tapping screws
The wheels are mounted on ball bearings.

Materials

Pulley external support in extruded aluminium
Reinforced polyamide wheel on steel ball bearings

Capacities

Max. 200 kg with 2 pulleys

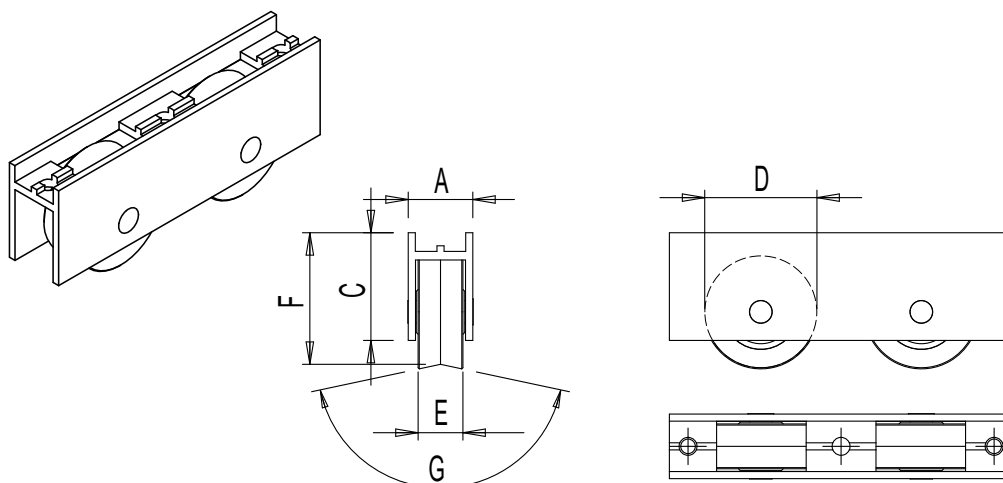

Item code	Description	Note	Load capacity (kg)	A [mm]	C [mm]	D [mm]	E [mm]	F [mm]	G [°]	Bearing	Base Raw	Anodised Elox	Painted	Trend/Gold Brass	Pieces per pack
03041	DOUBLE WHEEL PULLEY	set of 4 pieces	100	17,3	28,9	28	12	35,3	156°	Balls	X				25



BRIO EVO HANDLE

Functions

Reversible recessed handle, with the possibility of manual mode operation (for door) or automatic operation (for window), to enable side locking of sliding sashes.

Online data sheet



Technical Features

The Brio Evo handle allows crossing and overlapping of the two sashes and it is fixed to the profile quickly and precisely by inserting the bottom part of the handle in the slot and then pressing down the top part.

After determining the optimum position of the nib (and therefore locking), it is secured with a grub screw, located under the covering cap.

The polyamide slider has two green and red surfaces that indicate respectively sash open and sash closed.

The Brio Evo handle is fitted with an antilifting system to ensure that the casement can only be opened by moving the small polyamide recess handle on the interior.

The product is preset as standard for automatic operation (for window); for manual mode operation (for door) the pre-assembled spring on the product must be eliminated. The screw supplied must be screwed onto the nib carrier if the handle has to perform the burglar-proof function in manual mode operation.

The product is available in two different styles: rounded design and square design. Each style is available with 2-teeth or 1-tooth spring fixing, a solution to be chosen based on the type of sash profile used.

Materials

Body in extruded aluminium

Slider in white die-cast zinc plated Zamak

Polyamide recess handle

Stainless steel grub screw

Harmonic steel spring for automatic operation

Bottom fixing spring in C70 Geomet steel

Parts

1 screw for burglar-proof function

0299202

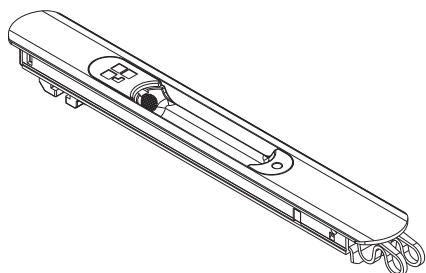

06004

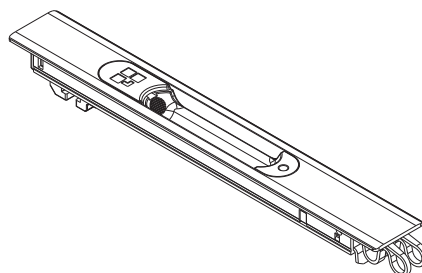

0298201

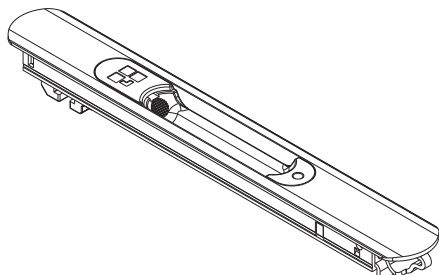

06006

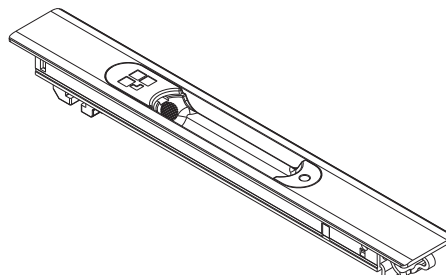

Machining on profile

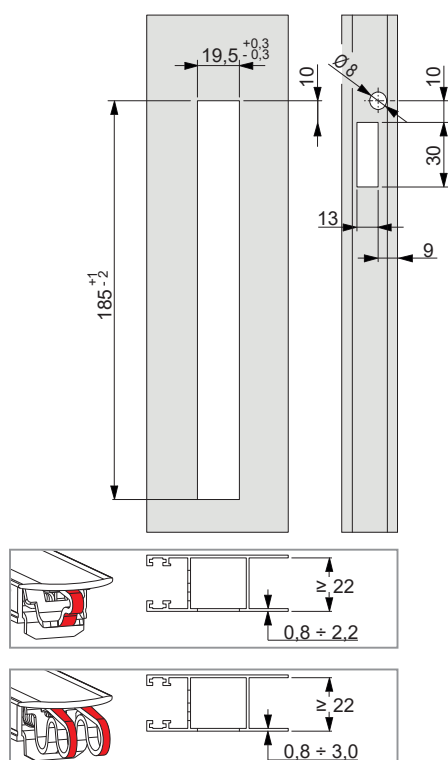

A: 2-teeth spring - B: 1-tooth spring

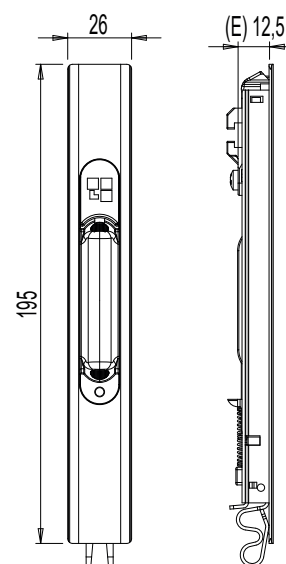
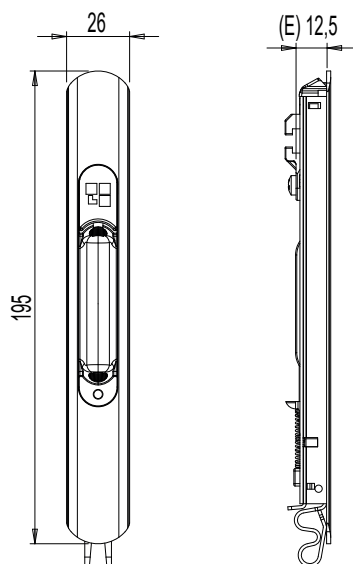
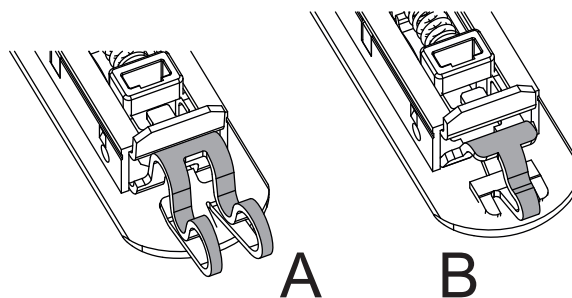

Item code	Description	Design	Backset E [mm]	Fixing spring	Matching handles (Inside)	Matching handles (Outside)	Base Raw	Anodised Elox	Painted	Trend/Gold Brass	Pieces per pack
0298201	BRIO EVO MD HANDLE	Rounded	12,5	1-tooth (B)	03043 - 03050 - 03064	02966N - 02967V - 02996	X		X		20
0299202	BRIO EVO HANDLE	Rounded	12,5	2 teeth (A)	03043 - 03050 - 03064	02966N - 02967V - 02996	X	X	X	X	20
06004	BRIO EVO HANDLE	Square	12,5	2 teeth (A)	03043 - 03050 - 03064	-	X		X	X	20
06006	BRIO EVO MD HANDLE	Square	12,5	1-tooth (B)	03043 - 03050 - 03064	-	X		X	X	20



BRIO EVO KEY HANDLE

Functions

Reversible recessed handle, with manual mode operation (for door) enabling side locking of sliding sashes.

Online data sheet



Technical Features

The Brio Evo Key handle allows crossing and overlapping of the two sashes and the end-user can lock the handle in the closed or open position by means of the special key supplied.

After determining the optimum position of the nib (and therefore locking), it is secured with a grub screw, located under the covering cap.

The polyamide slider has two green and red surfaces that indicate respectively sash open and sash closed.

The Brio Evo Key handle is fitted with an antilifting system to ensure that the casement can only be opened by moving the small polyamide recess handle on the interior.

The product is available in two different styles: rounded design and square design. Each style is available with 2-teeth or 1-tooth spring fixing, a solution to be chosen based on the type of sash profile used.

The cylinder is provided with the same keys, on request you can have different keys with 50 different combinations.

Materials

Body in extruded aluminium

Slider in white die-cast zinc plated Zamak

Polyamide recess handle

Zinc plated steel keys

Zamak key cylinder

Stainless steel grub screw

Harmonic steel spring for automatic operation

Bottom fixing spring in C70 Geomet steel

0288201

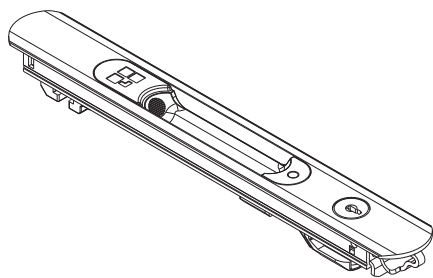

0289201

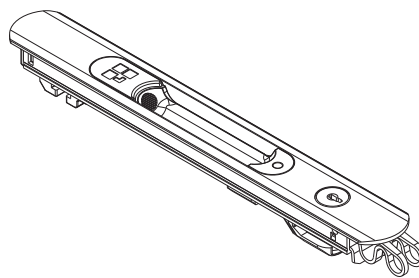

06005

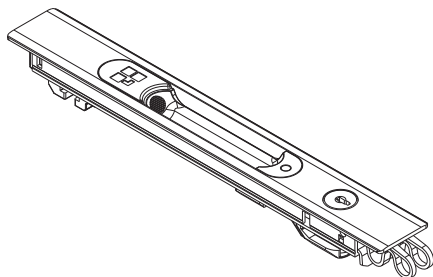

06007

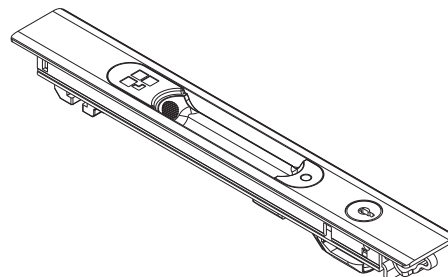

Machining on profile

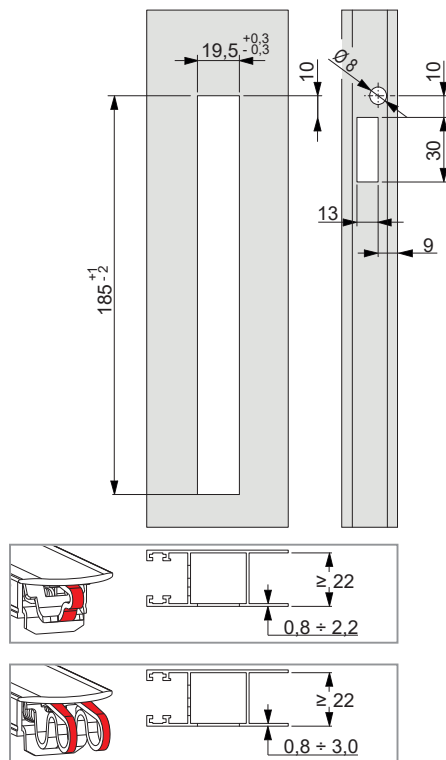

A: 2-teeth spring - B: 1-tooth spring

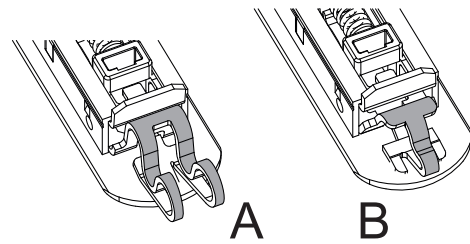

Block on closing and opening

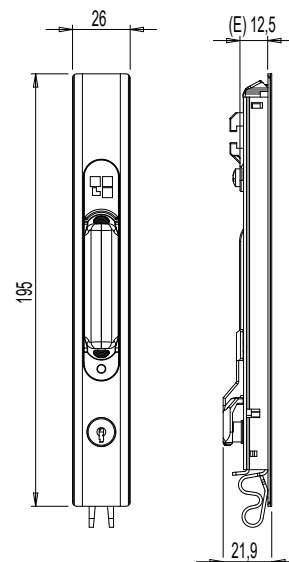
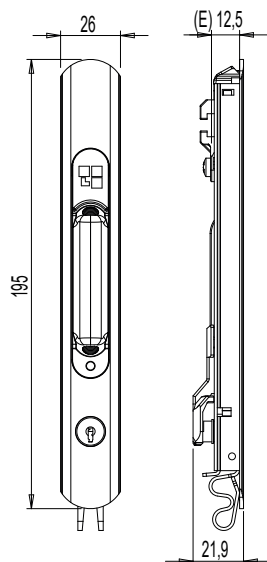
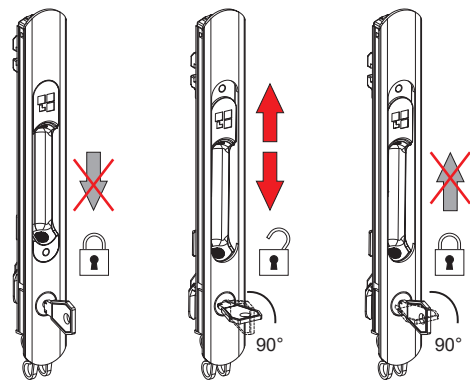

Item code	Description	Design	Backset E [mm]	Fixing spring	Matching handles (Inside)	Matching handles (Outside)	Base Raw	Anodised Elox	Painted	Trend/Gold Brass	Pieces per pack
0288201	BRIO EVO KEY MD HANDLE	Rounded	12,5	1-tooth (B)	03043 - 03050 - 03064	02966N	X		X		5
0289201	BRIO EVO KEY HANDLE	Rounded	12,5	2 teeth (A)	03043 - 03050 - 03064	02966N	X		X		5
06005	BRIO EVO KEY HANDLE	Square	12,5	2 teeth (A)	03043 - 03050 - 03064	02966N	X		X	X	5
06007	BRIO EVO KEY MD HANDLE	Square	12,5	1-tooth (B)	03043 - 03050 - 03064	02966N	X		X		5



BRIO KEY DRIVE HANDLE WITH BRIO EVO

Functions

Recessed Brio Evo handle with snap coupling, with external security key-lock handle for side closure of the sashes of an aluminium sliding door.

Online data sheet



Technical Features

The handle's slider on the inside of the sash can be operated externally with a key to open or close the sash. From inside, the sash's lock can be made by directly using the slider.

The product features a different key (KD) lock, on request it is possible to have the product in the same key (KA) version.

Sash profile width: min. 25 mm max. 47 mm.

Fitting is quick, accurate and easy.

Two slots must be made (187x19.5mm) in perfect alignment and of the same size on the sash stile.

Materials

Recessed handle - inside:

- Extruded aluminium body
- Slider in white die-cast zinc plated Zamak
- Recess handle in nylon
- Stainless steel grub screw
- White zinc plated steel spring for automatic operation

External handle with key - outside:

- Body in die-cast zamak
- Upper and lower fork in white zinc plated zamak
- Lower fixing HSCH screw M5x10 in stainless steel
- Nickel-plated brass cylinder

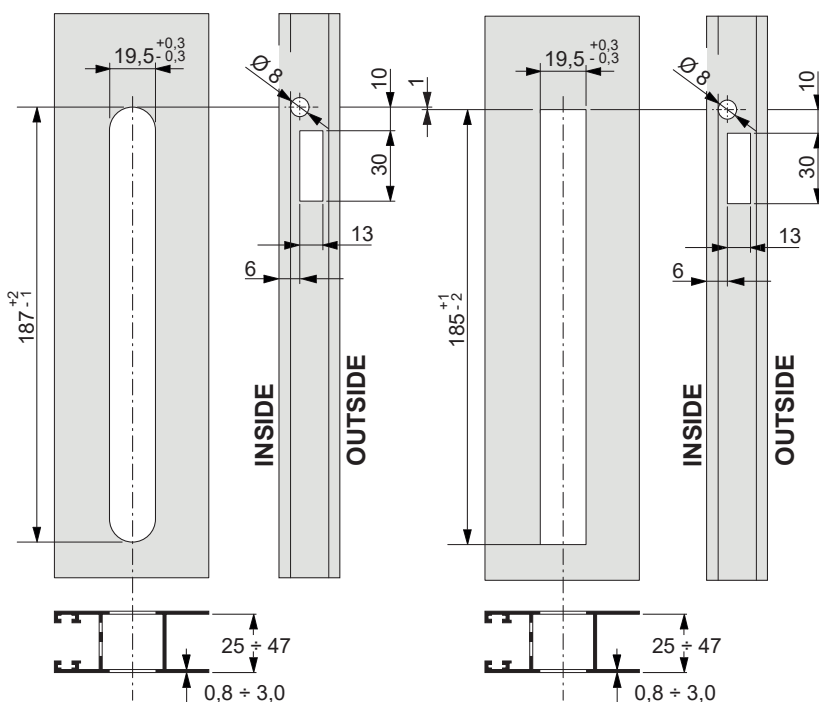

A: 2-teeth spring - B: 1-tooth spring

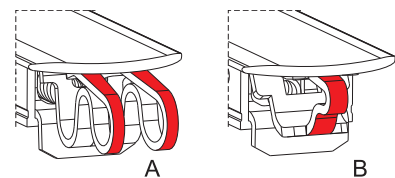

Handle setup - A: 2 teeth - B: 1 tooth

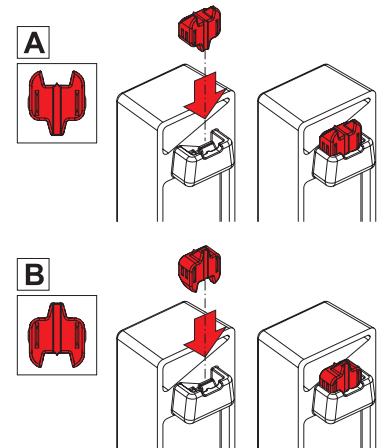

06037

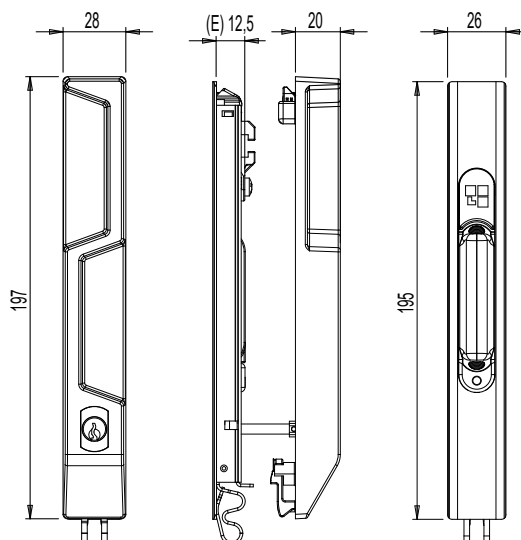
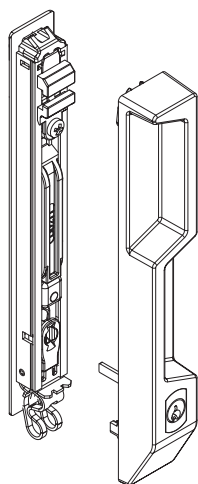

06052

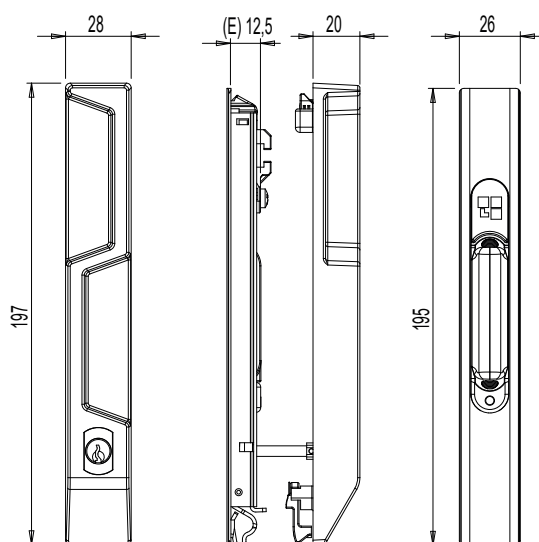
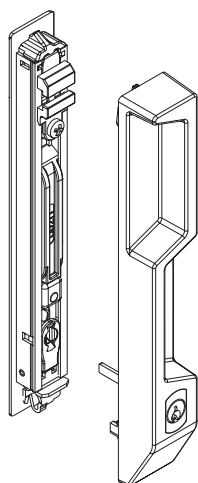

Item code	Description	Backset E [mm]	Design	Fixing spring	Base Raw	Anodised Elox	Painted	Trend/Gold Brass	Pieces per pack
06037	SQUARE BRIO EVO EXTERNAL HANDLE WITH KEY	12,5	Square	2 teeth (A)	X		X		5
06052	SQUARE BRIO EVO MD EXTERNAL HANDLE WITH KEY	12,5	Square	1-tooth (B)	X		X		5

RECESSED HANDLES



BRIO KEY RECESSED HANDLE WITH BRIO EVO

Functions

Recessed Brio Evo handle with snap coupling, with external security key-lock recess handle for side closure of the sashes of an aluminium sliding door.

Online data sheet



Technical Features

The handle's slider on the inside of the sash can be operated externally with a key to open or close the sash.

From inside, the sash's lock can be made by directly using the recessed handle slider.

The product features a same key (KA) lock.

Sash profile width: minimum 25 mm - maximum 55 mm.

Fitting is quick, accurate and easy.

Two slots must be made (187x19.5mm) in perfect alignment and of the same size on the sash stile.

Materials

Recessed handle - inside:

- Extruded aluminium body
- Slider in white die-cast zinc plated Zamak
- Recess handle in nylon
- Stainless steel grub screw
- White zinc plated steel spring for automatic operation

Recessed handle with key - outside:

- Body in die-cast zamak
- Upper and lower fork in white zinc plated zamak
- Lower fixing HSCH screw M5x8 in stainless steel
- Nickel-plated brass cylinder

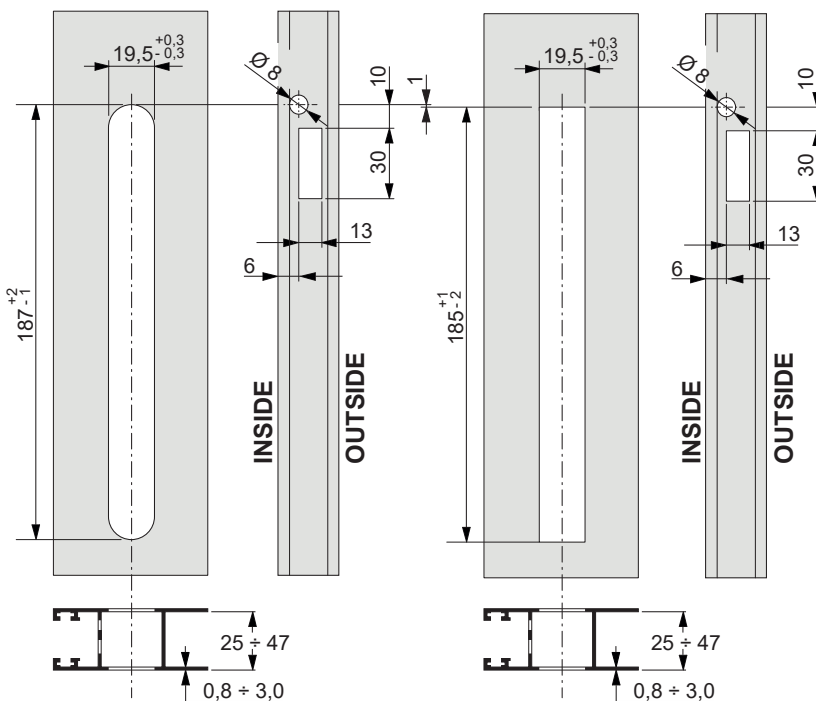

A: 2-teeth spring - B: 1-tooth spring

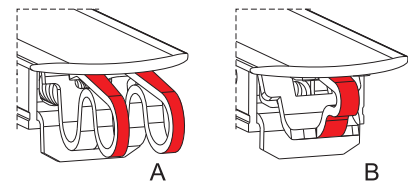

Handle setup - A: 2 teeth - B: 1 tooth

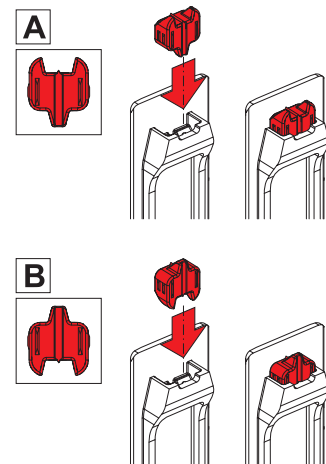

06019

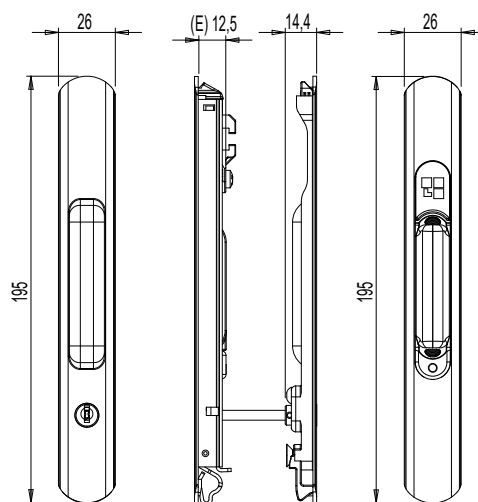
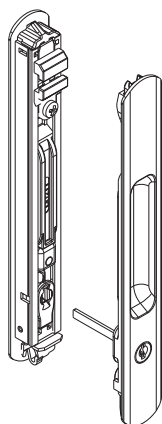

06039

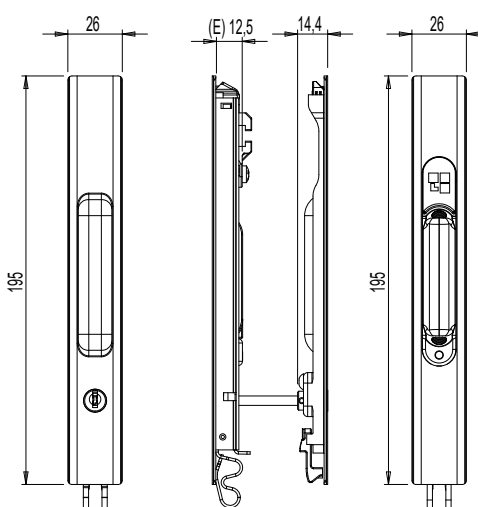
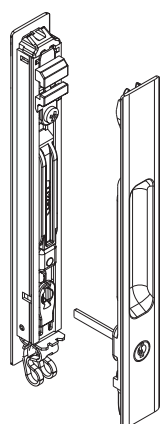

06054

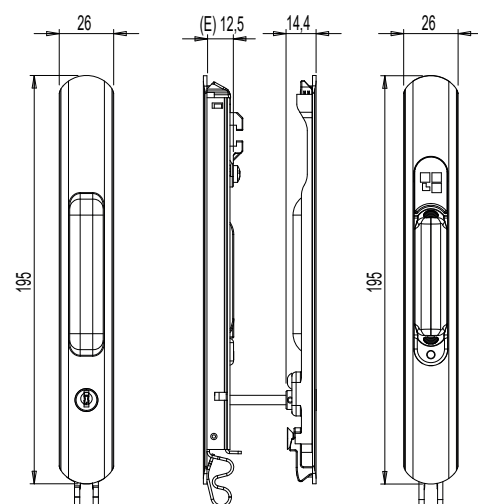
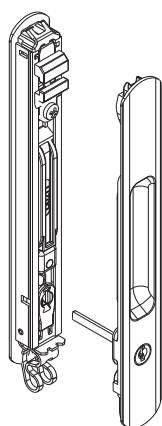

Item code	Description	Backset E [mm]	Design	Fixing spring	Base Raw	Anodised Elox	Painted	Trend/Gold Brass	Pieces per pack
06019	ROUNDED BRIO EVO MD EXTERNAL RECESSED HANDLE WITH KEY	12,5	Rounded	1-tooth (B)	X		X		5
06039	SQUARED BRIO EVO EXTERNAL RECESS HANDLE WITH KEY	12,5	Square	2 teeth (A)	X		X		5
06054	ROUNDED BRIO EVO EXTERNAL RECESS HANDLE WITH KEY	12,5	Rounded	2 teeth (A)	X		X		5



BRIO MINI EVO HANDLE

Functions

Reversible recessed handle, with automatic operation (for window) to enable side locking of sliding sashes.

[Online data sheet](#)



Technical Features

The Brio Mini Evo handle allows crossing and overlapping of the two sashes and is fixed to the profile quickly and precisely by inserting the bottom part of the handle in the slot, then pressing down the top part.

After setting the optimal position of the nib (and thus the lock) it is secured by means of a grub screw on its front, while holding the polyamide recess handle down.

The product is available in two different styles: rounded design and square design. Each style is available with 2-teeth or 1-tooth spring fixing, a solution to be chosen based on the type of sash profile used.

Materials

Body in extruded aluminium

Polyamide control slider

Polyamide recess handle

Upper fixing component and nib-holder in zinc plated zamak

Stainless steel grub screw

Harmonic steel spring for automatic operation

Bottom fixing spring in C70 Geomet steel

0298802

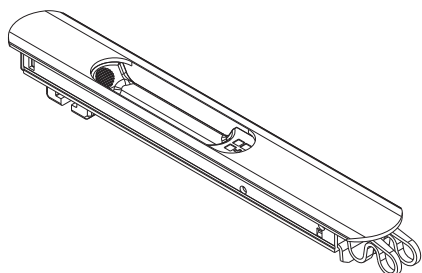

06038

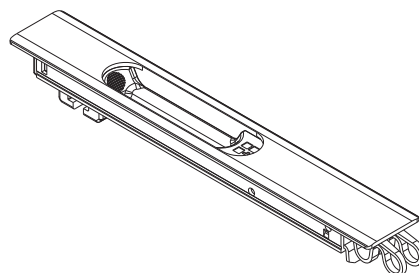

0297801

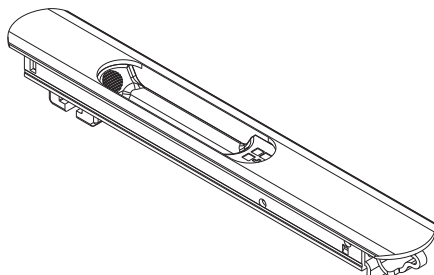

06018

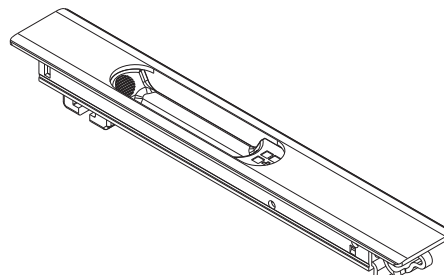

Machining on profile

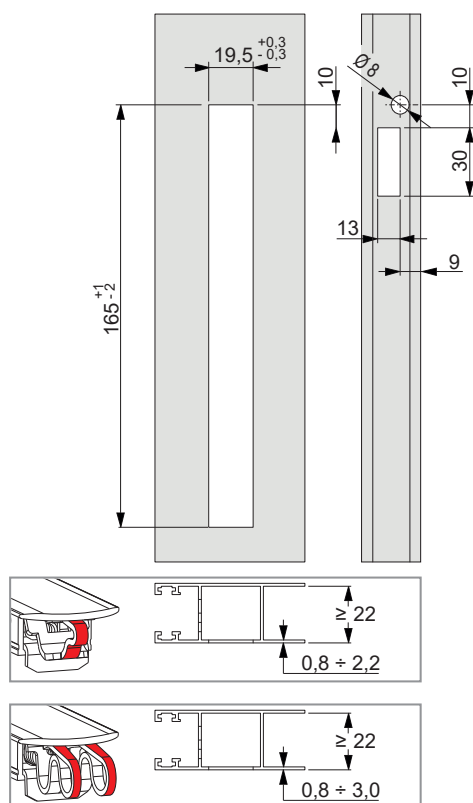

A: 2-teeth spring - B: 1-tooth spring

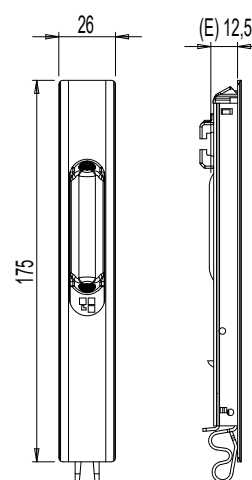
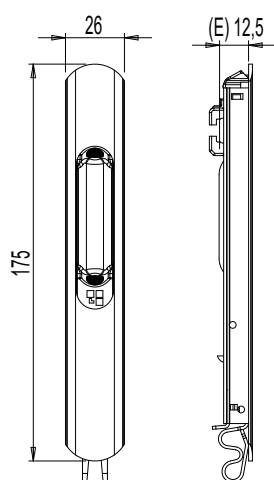
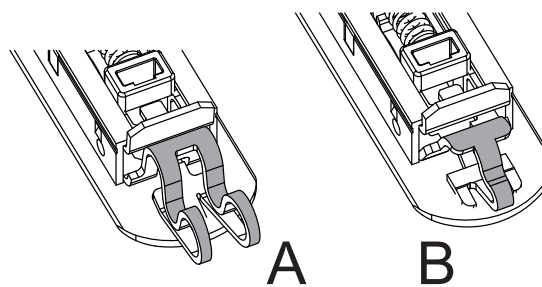

Item code	Description	Design	Backset E [mm]	Fixing spring	Matching handles (Inside)	Matching handles (Outside)	Base Raw	Anodised Elox	Painted	Trend/Gold Brass	Pieces per pack
0297802	BRIO MINI EVO MD HANDLE	Rounded	12,5	1-tooth (B)	03043 - 03050 - 03064	-	X		X		20
0298802	BRIO MINI EVO HANDLE	Rounded	12,5	2 teeth (A)	03043 - 03050 - 03064	-	X	X	X	X	20
0601801	BRIO MINI EVO MD HANDLE	Square	12,5	1-tooth (B)	03043 - 03050 - 03064	-	X		X		20
0603801	BRIO MINI EVO HANDLE	Square	12,5	2 teeth (A)	03043 - 03050 - 03064	-	X		X		20



BRIO EVO L HANDLE

Functions

Reversible recessed handle, with the possibility of manual mode operation (for door) or automatic operation (for window), to enable side locking of sliding sashes.

Online data sheet



Technical Features

The Brio Evo L handle allows crossing and overlapping of the two sashes and it is fixed to the profile quickly and precisely by inserting the bottom part of the handle in the slot and then pressing down the top part.

After determining the optimum position of the nib (and therefore locking), it is secured with a grub screw, located under the covering cap.

A distinctive feature of Brio Evo L is the nib carrier depth of 18.8 mm (compared to 12.5 in the standard Brio Evo version) which, in the case of particularly wide sash profiles, makes it possible to reduce the nib anchoring.

The polyamide slider has two green and red surfaces that indicate respectively sash open and sash closed.

The Brio Evo handle is fitted with an antilifting system to ensure that the case-ment can only be opened by moving the small polyamide recess handle on the interior.

The product is preset as standard for automatic operation (for window); for manual operation (for door) the pre-assembled spring on the product must be eliminated.

The screw supplied must be screwed onto the nib carrier if the handle has to perform the burglar-proof function in manual mode operation.

Brio Evo L is available in two different styles: rounded design and square design, with two-teeth fixing spring.

Materials

Body in extruded aluminium

Slider in white die-cast zinc plated Zamak

Polyamide recess handle

Stainless steel grub screw

Harmonic steel spring for automatic operation

Bottom fixing spring in C70 Geomet steel

Parts

1 screw for burglar-proof function

0289401

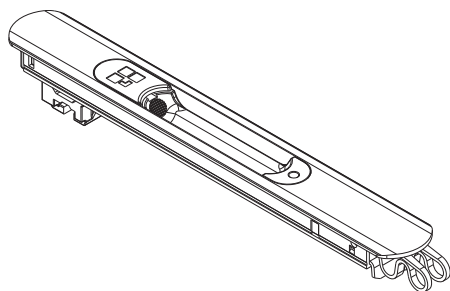

06008

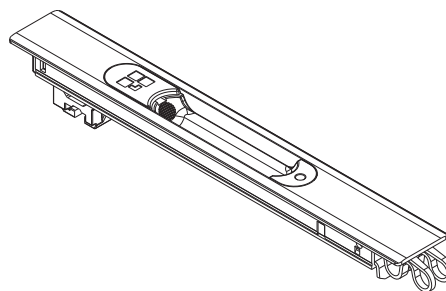

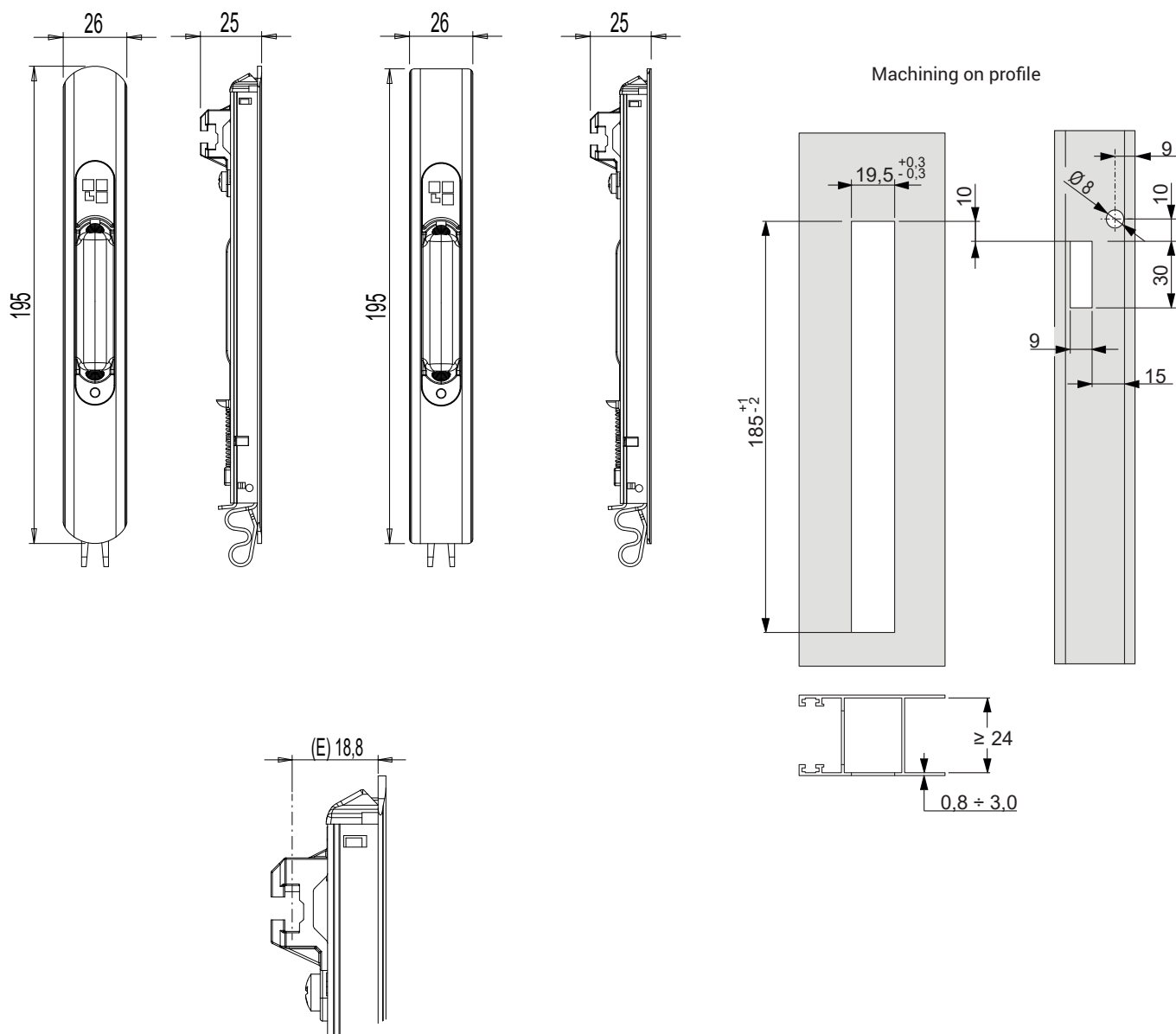

Item code	Description	Design	Backset E [mm]	Fixing spring	Matching handles (Inside)	Matching handles (Outside)	Base Raw	Anodised Elox	Painted	Trend/Gold Brass	Pieces per pack
0289401	BRIO EVO L HANDLE	Rounded	18,8	2 teeth (A)	03043 - 03050 - 03064	02966N	X		X		20
06008	BRIO EVO L HANDLE	Square	18,8	2 teeth (A)	03043 - 03050 - 03064	02966N	X	X	X	X	20



BRIO EVO XL HANDLE

Functions

Reversible recessed handle, with the possibility of manual mode operation (for door) or automatic operation (for window), to enable side locking of sliding sashes.

Online data sheet



Technical Features

The Brio Evo XL handle allows crossing and overlapping of the two sashes and it is fixed to the profile quickly and precisely by inserting the bottom part of the handle in the slot and then pressing down the top part.

After determining the optimum position of the nib (and therefore locking), it is secured with a grub screw, located under the covering cap.

A distinctive feature of Brio EVO XL is the nib carrier depth of 24.3 mm (compared to 12.5 in the standard Brio Evo version) which, in the case of particularly wide sash profiles, makes it possible to reduce the nib anchoring.

The polyamide slider has two green and red surfaces that indicate respectively sash open and sash closed.

The Brio Evo XL handle is fitted with an antilifting system to ensure that the casement can only be opened by moving the small polyamide recess handle on the interior.

The product is preset as standard for automatic operation (for window).

For manual operation (for door) the pre-assembled spring on the product must be eliminated.

BRIO XL is available in two different styles: rounded design and square design, with two-teeth fixing spring.

Materials

Body in extruded aluminium

Slider in white die-cast zinc plated Zamak

Polyamide recess handle

Stainless steel grub screw

Harmonic steel spring for automatic operation

Bottom fixing spring in C70 Geomet steel

0087302

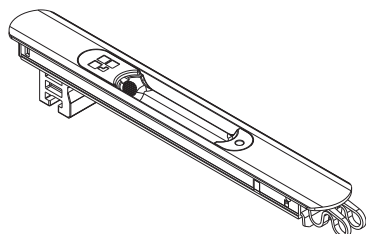

06009

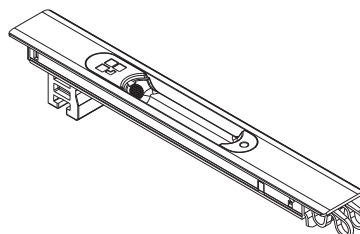

00878

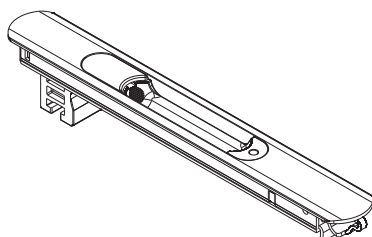

06015

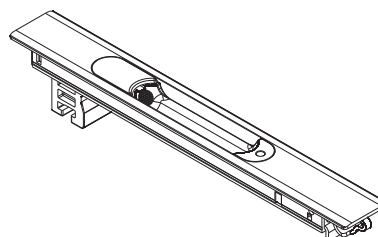

Machining on profile

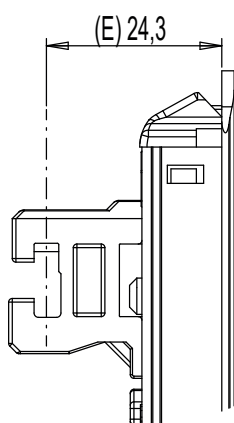
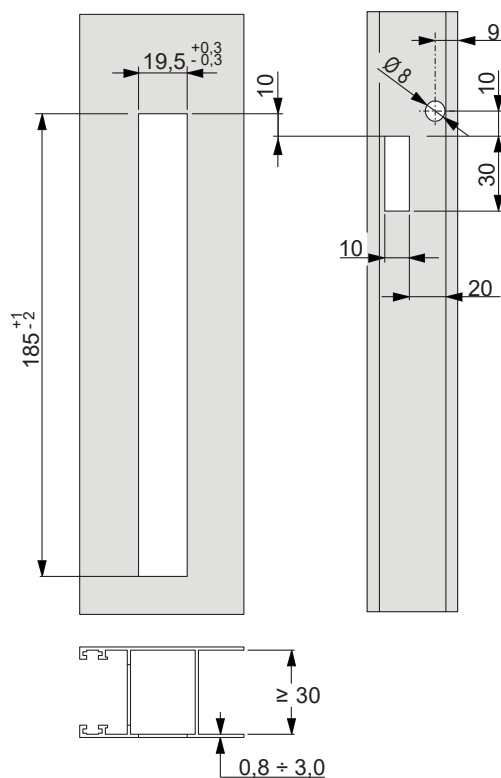
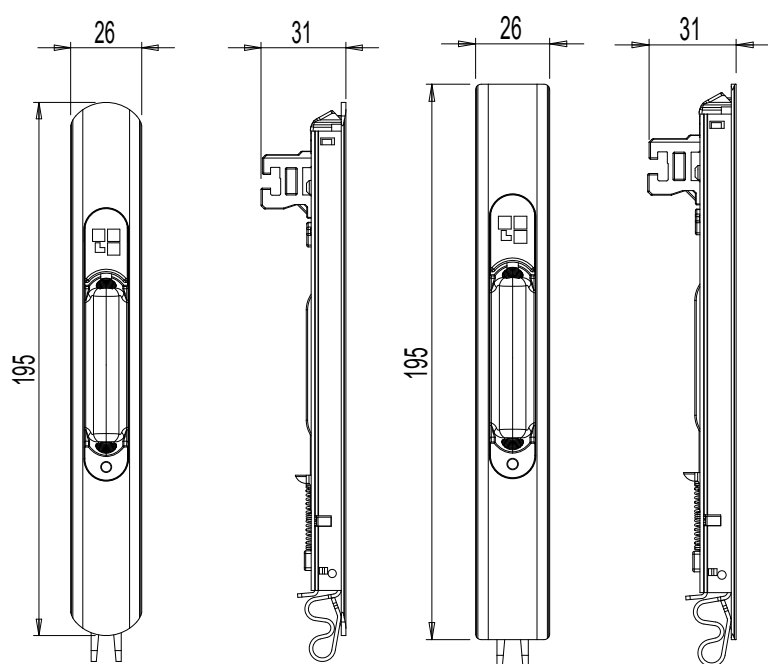

A: 2-teeth spring - B: 1-tooth spring

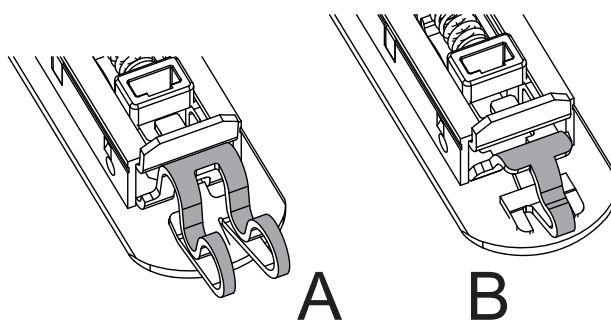

Item code	Description	Design	Backset E [mm]	Fixing spring	Matching handles (Inside)	Matching handles (Outside)	Base Raw	Anodised Elox	Painted	Trend/Gold Brass	Pieces per pack
0087302	BRIO EVO XL	Rounded	24,3	2 teeth (A)	03043 - 03050 - 03064	02966N - 06014	X		X		20
00878	BRIO EVO XL	Rounded	24,3	1-tooth (B)	03043 - 03050 - 03064	02966N - 06014	X		X		20
06009	BRIO EVO XL	Square	24,3	2 teeth (A)	03043 - 03050 - 03064	02966N - 06014	X		X		20
06015	BRIO EVO XL	Square	24,3	1-tooth (B)	03043 - 03050 - 03064	02966N - 06014	X		X		20

RECESSED HANDLES



ROUNDED BRIO RAPID EVO HANDLE

Functions

Reversible recessed handle, with the possibility of manual operation (for doors) or automatic operation (for windows), to enable side locking of sliding sashes.

Online data sheet



Technical Features

The Brio handle allows crossing and overlapping of the two sashes. Prepared for the manual function, it is equipped with a spring that when installed enables the automatic function. The Brio handle is secured by tightening the two screws which oppose two fixing plates. After determining the optimum position of the nib (and therefore locking), it is secured with a grub screw, located under the covering cap. The polyamide slider has two green and red surfaces that indicate respectively sash open and sash closed. The Brio handle is equipped with an antilifting system that increases the security of the casement, preventing the nib from unhooking in the event the sash is lifted from its seat. This system is active when the Brio handle is used on its own or when combined with the recess handle or with the external drive rod handle. It is not active when the Brio is combined with the Brio external handle with key.

Materials

Body in extruded aluminium
Slider and fixing plates in die-cast zamak
Plug to enable automatic mode and recess handle in polyamide
Grub screws and screws in stainless steel
Steel spring for automatic operation

Parts

1 Spring for automatic function

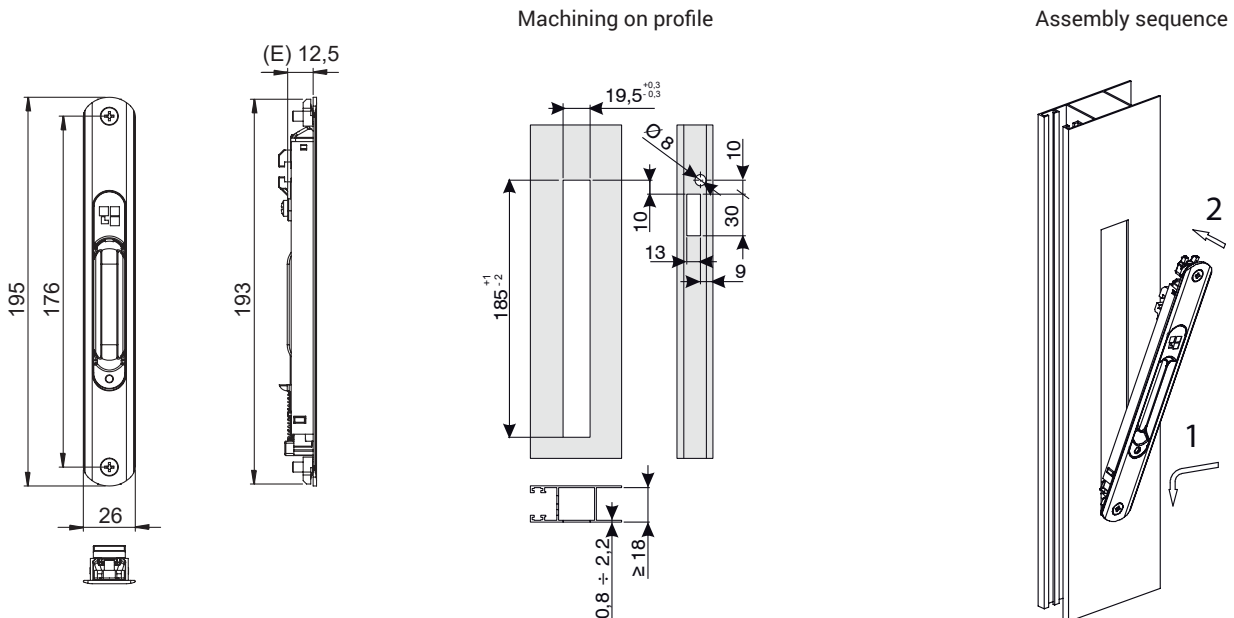

Item code	Description	Backset E [mm]	Base Raw	Anodised Elox	Painted	Trend/Gold Brass	Pieces per pack
0083101	ROUNDED BRIO RAPID EVO HANDLE	12,5	X		X		20



BLIND BRIO EVO HANDLE

Functions

The Brio Evo Cieca handle performs the simple function of driving a sliding rod in the case of 4-sash casements with opposing sashes.

Online data sheet



Technical Features

The product is fitted to the internal side of the casement with the function of driving a sliding sash.
This hardware is generally fitted to one of the 2 opposing sashes of a 4-sash sliding casement to obtain an aesthetic match with the main recessed handle that operates the window locking point.

Materials

Body made of extruded aluminium
Recess handle in nylon
Lower fixing spring made of harmonic steel
Top fixing component made of galvanised zamak

Machining on profile

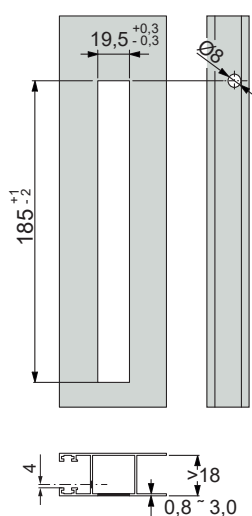

Assembly sequence

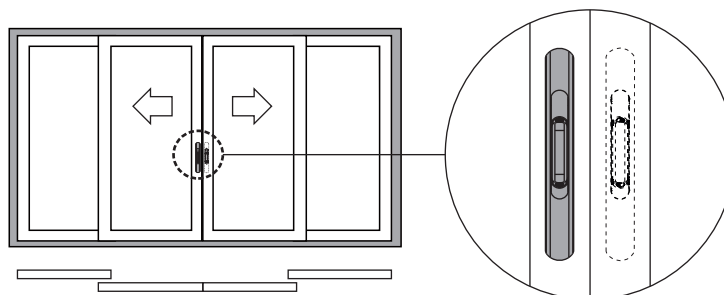
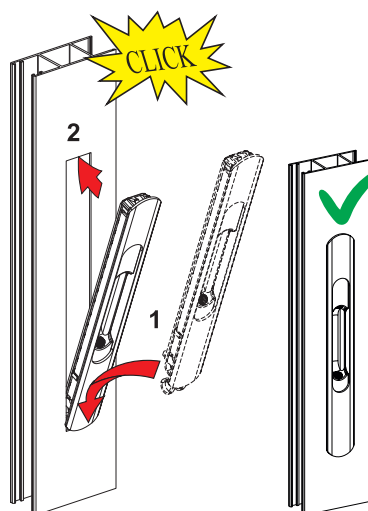

Item code	Description	Fixing type	Base Raw	Anodised Elox	Painted	Trend/Gold Brass	Pieces per pack
0289501	BLIND BRIO EVO HANDLE	Snap-mounting	X	X	X	X	20

RECESSED HANDLES



NADA HANDLE

Functions

Recessed reversible handle with automatic and manual locking for side closure and simultaneous overlap of the sashes of an aluminium sliding door/window.

Online data sheet



Technical Features

The handle is intended for automatic operation. It may however be set for manual use by removing the spring at its rear. The nib protrusion can be adjusted even with the handle mounted. The nib is set with a grub screw located on the front of the slider. The NADA handle features simple front fixing using pre-assembled brackets.

Materials

Black polyamide body.
Extruded aluminium control slider.
Zinc plated steel plates.

The X dimension depends on the series used

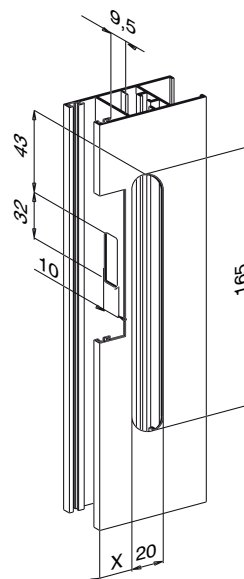
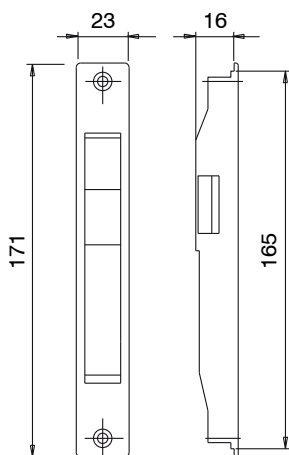

Item code	Description	Note	Base Raw	Anodised Elox	Painted	Trend/Gold Brass	Pieces per pack
03000	NADA HANDLE	only finish 500		X	X		20



PRATIKA HANDLE

Functions

Reversible recessed handle with automatic and manual locking for side closure and simultaneous overlap of the sashes of an aluminium sliding door or window.

Online data sheet



Technical Features

Locking can be manual or automatic.
Simply remove the surplus spring to select the type of operation desired.
The protrusion of the fixture kit nib can be adjusted precisely with the grub screw, which is accessible even with the handle already installed.
Once the optimal closure position has been determined, set it by tightening down the grub screw.
The slider has two coloured surfaces, green for handle open, red for handle closed.
The PRATIKA handle features simple front fixing using pre-assembled brackets.

Materials

Body in extruded aluminium
Slider, fixing plates and internal components in die-cast zamak.
Stainless steel grub screws and springs
Internal components in zinc plated Zamak

The X dimension depends on the series used

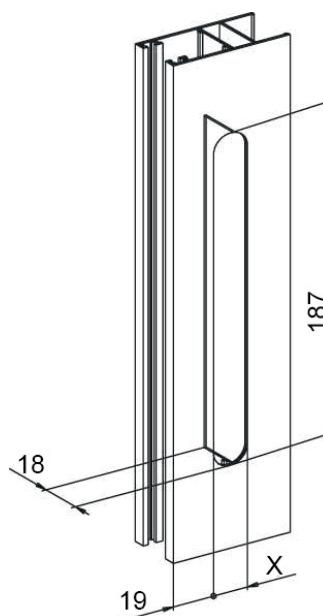
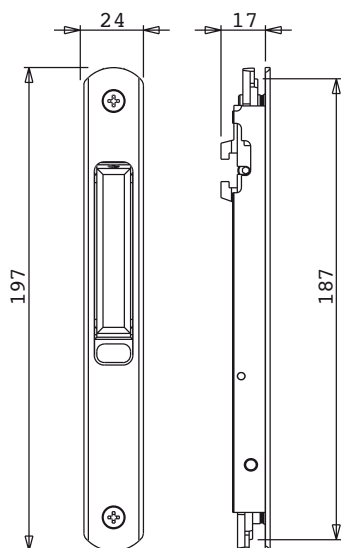

Item code	Description	Note	Base Raw	Anodised Elox	Painted	Trend/Gold Brass	Pieces per pack
03351	PRATIKA HANDLE	only painted finishes	X	X	X	X	20

PRATIKA DUO HANDLE



Functions

Recessed PRATIKA handle with manual locking, with external security key-lock for side closure and simultaneous overlap of the sashes of an aluminium sliding window, but more specifically for use on doors.

Online data sheet



Technical Features

From inside, the sash's lock can be engaged or left unengaged with the slider. Externally, the recess functions solely to provide a better grip for moving the sash.

The two housings are connected and secured with the supplied screws to ensure solid installation to the profile section.

Materials

Body in extruded aluminium.

Slider, fixing plate and internal components in die-cast zamak.

Stainless steel grub screws and spring.

The X dimension depends on the series used

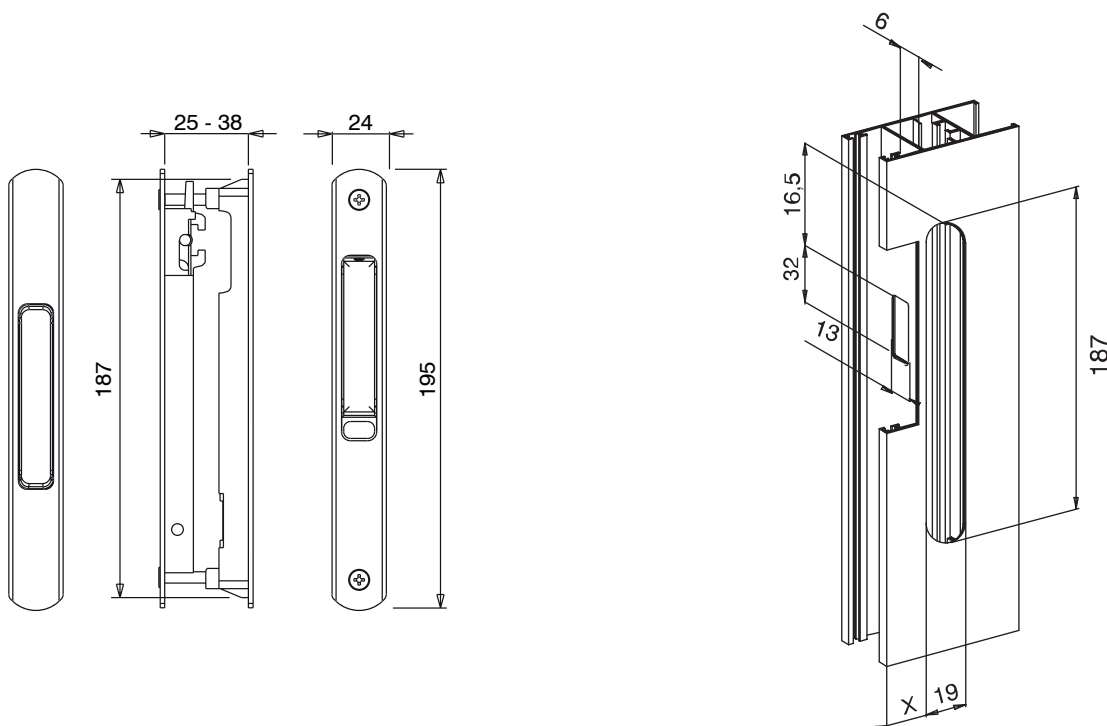

Item code	Description	Note	Base Raw	Anodised Elox	Painted	Trend/Gold Brass	Pieces per pack
03353	PRATIKA DUO HANDLE	only painted finishes	X	X	X	X	10



PRATIKA DUO KEY HANDLE

Functions

Recessed PRATIKA handle with manual locking, with external security key-lock for side closure and simultaneous overlap of the sashes of an aluminium sliding window, but more specifically for use on doors.

Online data sheet



Technical Features

The handle's slider can be operated externally with a key to open or close the sash.

From inside, the sash's lock can be engaged or left unengaged with the slider. The two housings are connected and secured with the supplied screws to ensure solid installation to the profile section.

The lock allows an excellent number of combinations and the possibility of having systems with the same key (KA) or master key (MK).

Materials

Body in extruded aluminium.

Slider, fixing plates and internal components in die-cast zamak.

Stainless steel grub screws and spring.

The X dimension depends on the series used

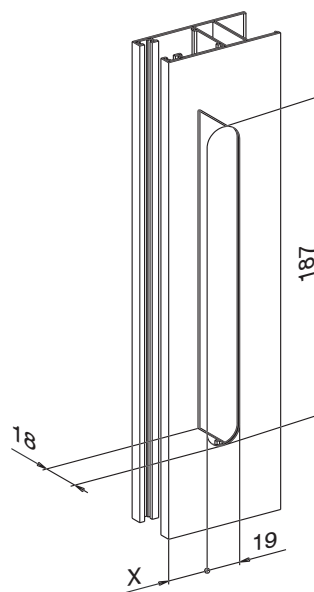
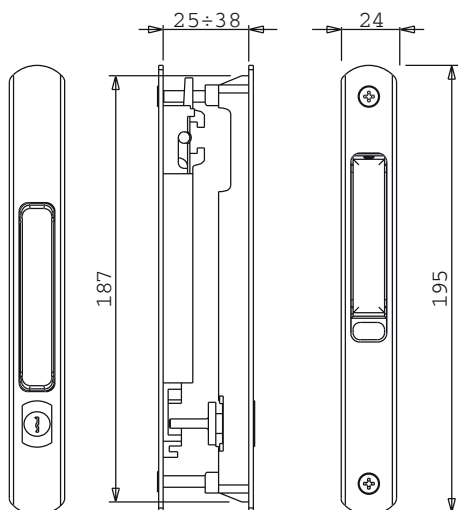

Item code	Description	Note	Base Raw	Anodised Elox	Painted	Trend/Gold Brass	Pieces per pack
03352	PRATIKA DUO HANDLE + LOCK	only painted finishes	X	X	X	X	10

EXTERNAL PULL HANDLES

BRIO PULL HANDLES



Functions

The external Brio pull handle, combined with a Brio or Brio MD recessed handle, enables the end user to move the wing of a sliding door with ease.

[Online data sheet](#)



Technical Features

The special ergonomic shape of the Brio external pull handle allows easy handling of a sliding door from the exterior side.

This article must always be mounted in combination with a Brio or Brio MD recessed handle.

Assembly is quick and precise. Two slots must be made (187x19.5mm) in perfect alignment and of the same size on the sash upright.

Materials

Body in die-cast zamak

Upper and lower fork in white zinc plated zamak

Upper and lower TSE M5x14 fixing screws in stainless steel

02966N

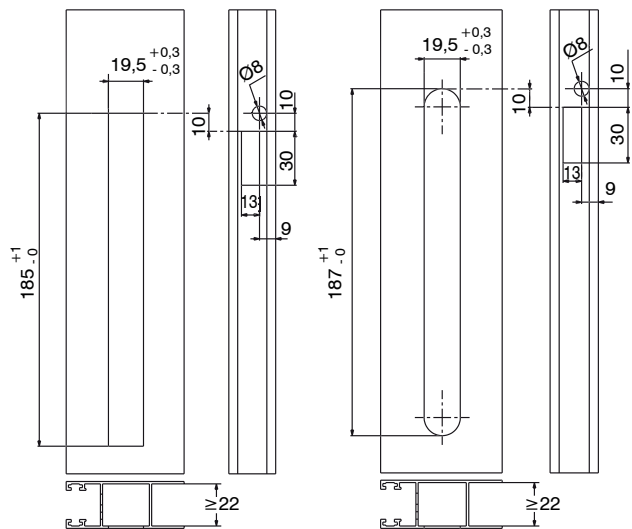
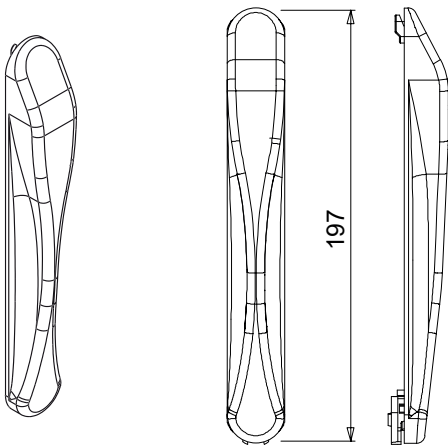

06014

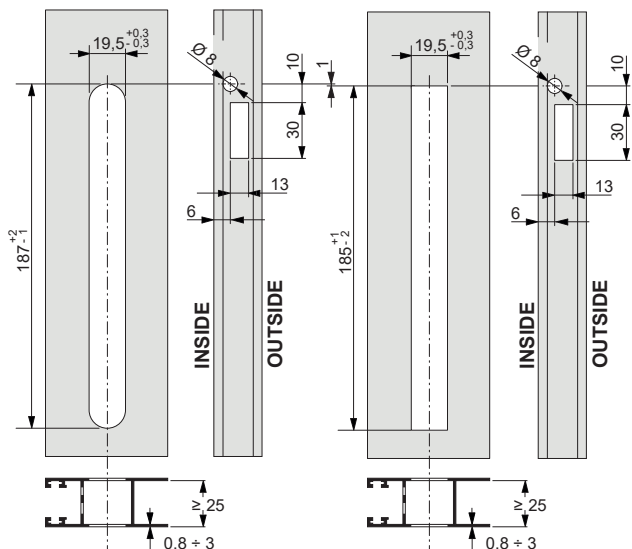
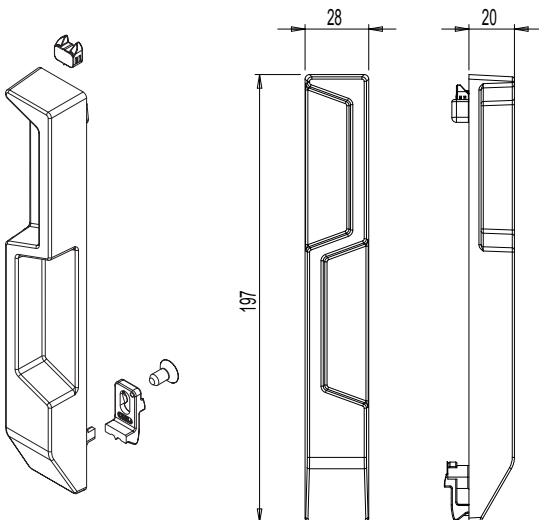

EXTERNAL PULL HANDLES

Assembly sequence art. 02966N

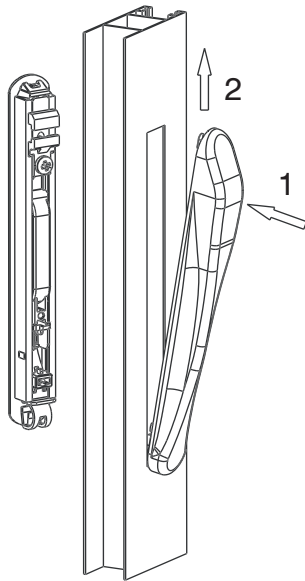

Assembly sequence art. 06014

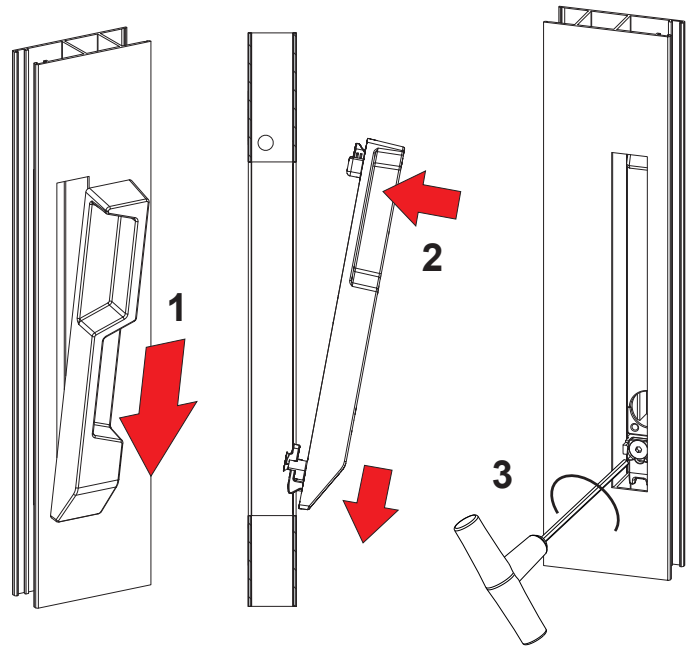

Art. 06014: 2-teeth coupling

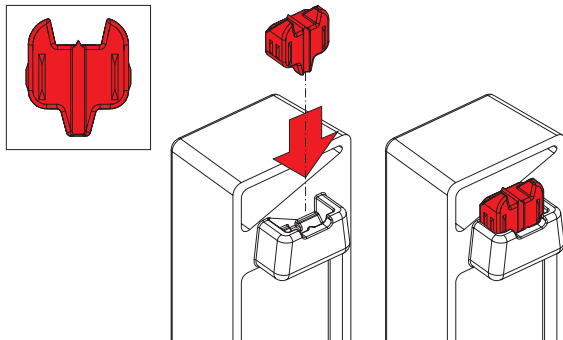

Art. 06014: 1-tooth coupling

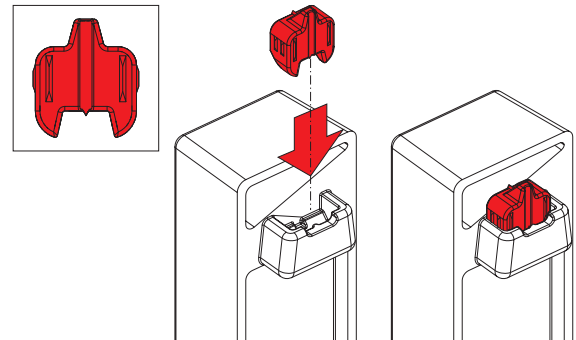

Item code	Description	Design	Matching handles (Inside)	Matching handles	Base Raw	Anodised Elox	Painted	Trend/Gold Brass	Pieces per pack
02966N	BRIO EXTERNAL PULL HANDLE	Rounded	03043 - 03064	0288201 - 0289201 - 0298201 - 0299202	X		X		5
06014	SQUARE EXTERNAL HANDLE	Square	03050	06004 - 06005 - 06006 - 06008 - 06009	X		X		5

EXTERNAL PULL HANDLES

BRIO KEY DRIVE ROD



Functions

The external Brio Key pull handle, combined with a Brio Evo or Brio Evo MD recessed handle, enables the end user to open and close a sliding door safely and easily.

Online data sheet



Technical Features

Available in two versions with European and Special cylinder (Giese). The special ergonomic shape of the Brio Key external pull handle allows easy handling of a sliding door.

On the external side, the key is used to activate the cylinder that opens and closes the sash. From inside, the sash's lock can be engaged or left unengaged by directly using the polyamide recess handle.

It should always be applied in combination with a Brio Evo or Brio Evo MD recessed handle, suitably prepared.

Assembly is quick and precise. Two slots must be made (187x19.5mm) in perfect alignment and of the same size on the sash upright.

The lock allows a high number of combinations and the possibility of having systems with the same key (KA) or master key (MK).

Materials

Body in die-cast zamak

Upper and lower fork and key bit in white zinc plated Zamak

Upper and lower TSE M5x14 fixing screws in stainless steel

Fibreglass reinforced polyamide shim

Fibreglass reinforced polyamide release element

Version with European cylinder and Special cylinder (Giese)

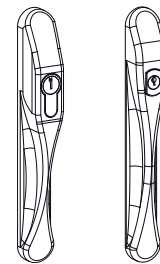
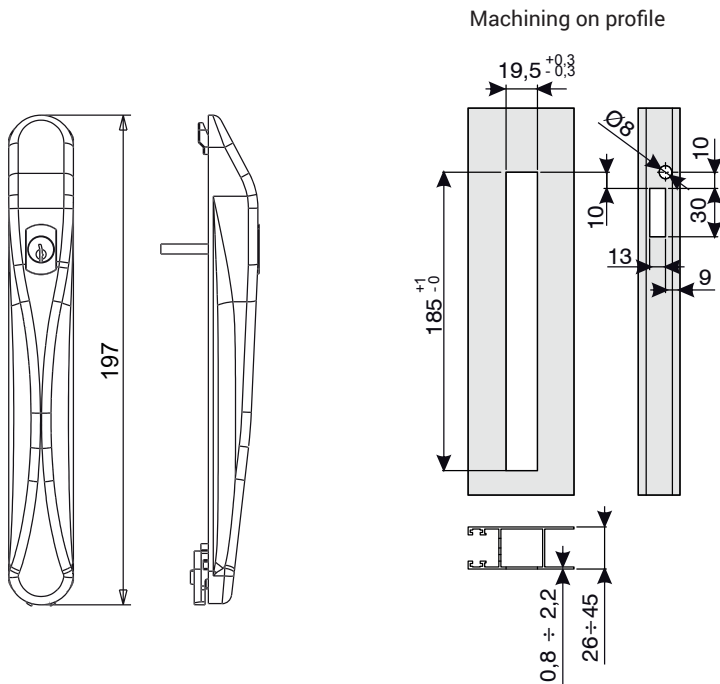

Assembly sequence

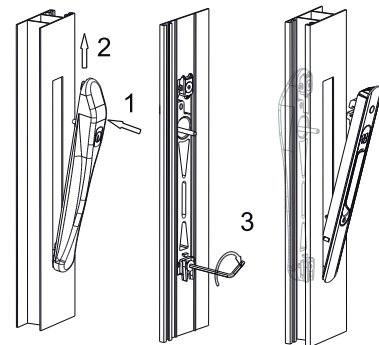

Item code	Description	Cylinder	Base Raw	Anodised Elox	Painted	Trend/Gold Brass	Pieces per pack
02967V	BRIO KEY EXTERNAL PULL HANDLE	Special	X		X		5
02996	BRIO KEY EXTERNAL PULL HANDLE	European	X		X		5

BRIO EVO RECESSED HANDLES

Functions

The external Brio pull handle, combined with a Brio EVO and Brio Evo MD recessed handle, enables the end user to move the sash of a sliding door easily and effortlessly.

[Online data sheet](#)



Technical Features

The Brio external flush-mounted pull handle allows easy handling of a sliding door from the exterior side.

The use of this product enables the overlap of the main and secondary sash. It should always be combined with a Brio EVO and Brio EVO MD recessed handle.

Sash profile width: min. 25 mm, max with no limits.

Fitting is quick, accurate and easy.

Two slots must be made (187x19.5mm) in perfect alignment and of the same size on the sash stile.

Materials

Body in die-cast zamak

Upper and lower fork in white zinc plated zamak

Lower fixing HSCH screw M5x8 in stainless steel

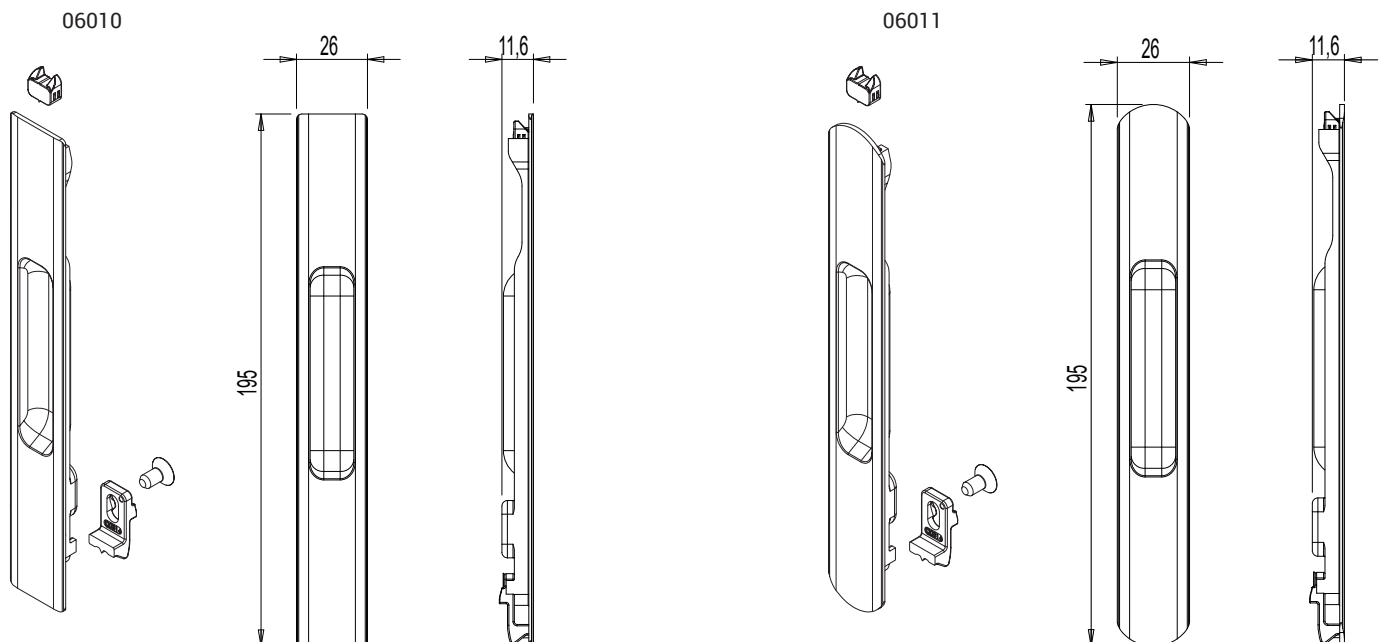

EXTERNAL PULL HANDLES

2-teeth coupling

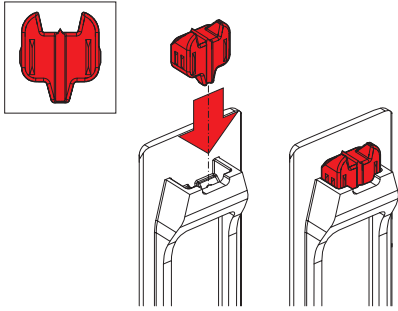

1-tooth coupling

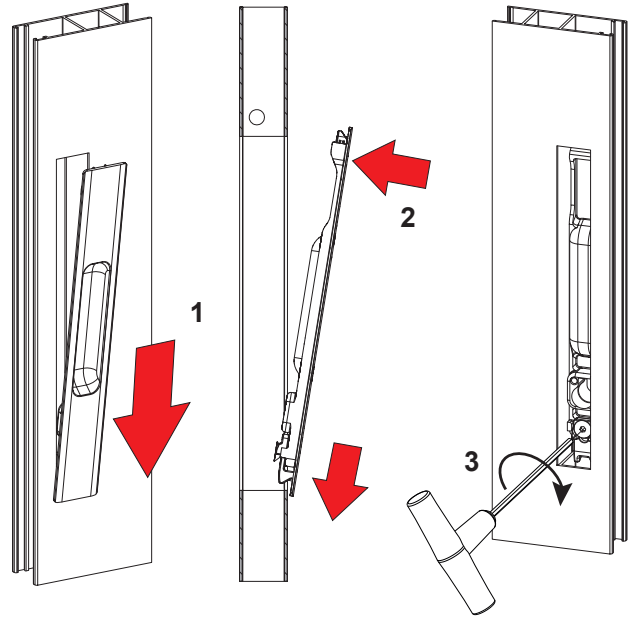
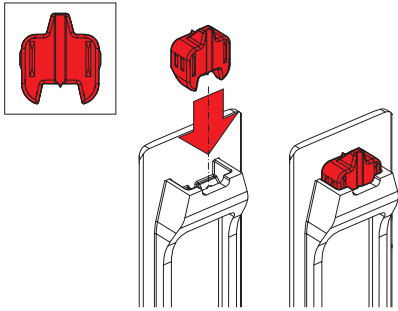

Machining on profile

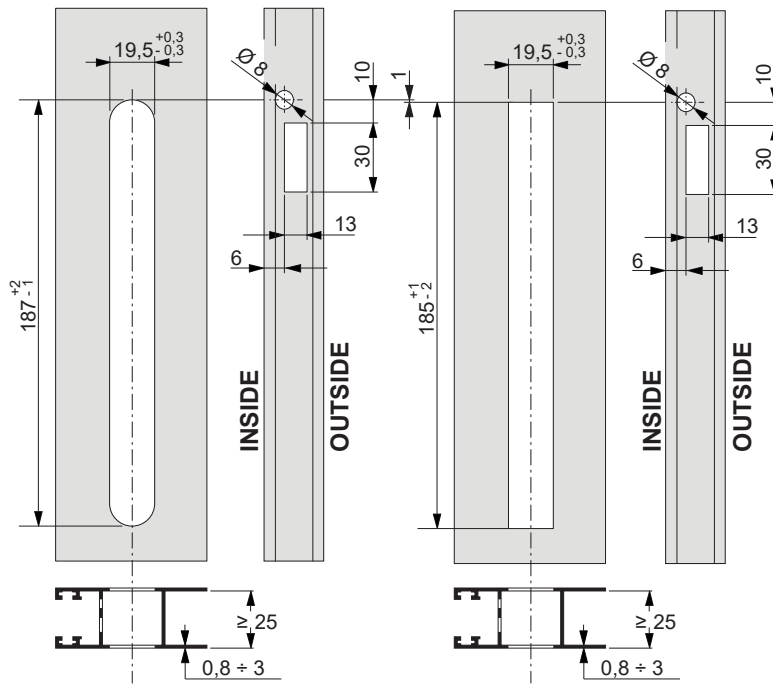

Item code	Description	Design	Matching handles (Inside)	Matching handles	Base Raw	Anodised Elox	Painted	Trend/Gold Brass	Pieces per pack
06010	SQUARE EXTERNAL RECESS PULL HANDLE	Square	03050	06004 - 06008 - 06009 - 06006 - 06005	X		X		5
06011	ROUNDED EXTERNAL RECESS PULL HANDLE	Rounded	03064 - 03034	0299202 - 0298201 - 0289401 - 0298201 - 0087302	X		X		5



RECESSED HANDLES

Functions

Recessed carry handle to facilitate moving the sashes of a sliding door or window from the outside.

Online data sheet



Technical Features

It is applied with specific machining and fixed with 2 self-tapping screws that are screwed into the handle reinforcement wall.

Materials

Black polyamide

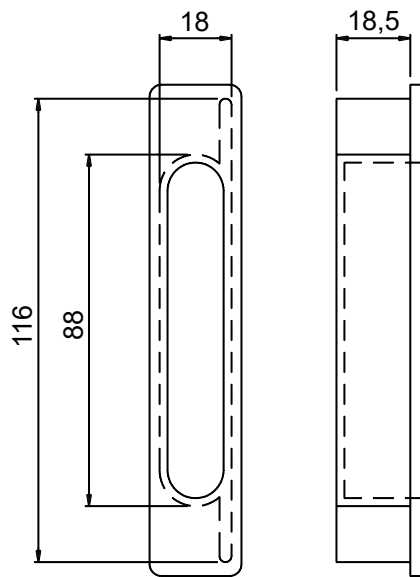

Item code	Description	Note	Base Raw	Anodised Elox	Painted	Trend/Gold Brass	Pieces per pack
02341	RECESSED CARRY HANDLE	black nylon	X				100

BRIO EVO SIDE DRIVE HANDLE

Functions

It is applied in combination with another Brio Evo recessed handle. Recommended for use on heavy aluminium sliding doors/windows to facilitate handling of the sashes.

Online data sheet

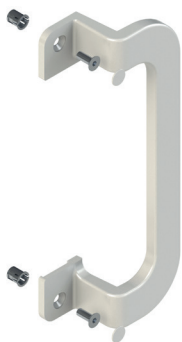

Technical Features

The Brio Evo side drive handle has an ergonomic grip to facilitate handling of heavy doors and windows.

Available in two versions with fixing in axis with the handle and a version with offset fixing, especially useful in the case of particularly heavy sashes, to avoid bending the wall.

This article is designed to give unrestricted access to the recess of the recessed handle.

Assembly is particularly fast, ensuring maximum durability.

Materials

Handle made of die-cast aluminium

HSCH screws in stainless steel

Rapid inserts in zinc plated steel

Screw cover caps in polyamide

Parts

2 TSE 6x16 screws

2 Rapid Inserts

2 Screw cover plugs

03043

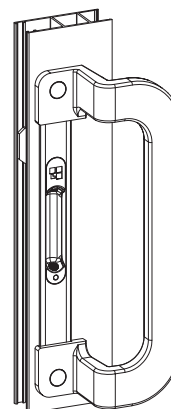
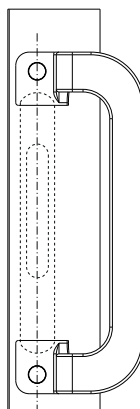
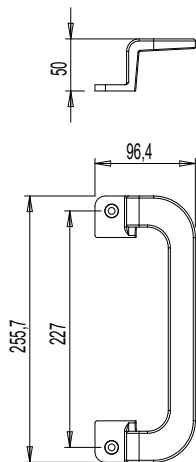
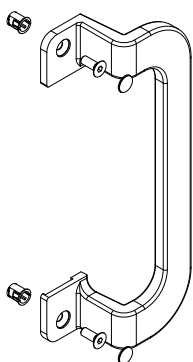

03050

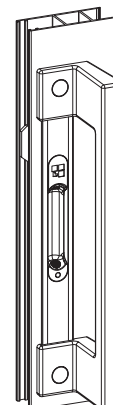
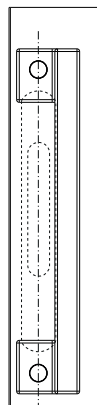
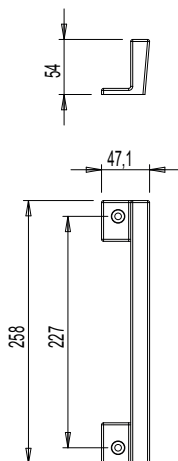
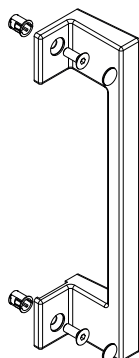

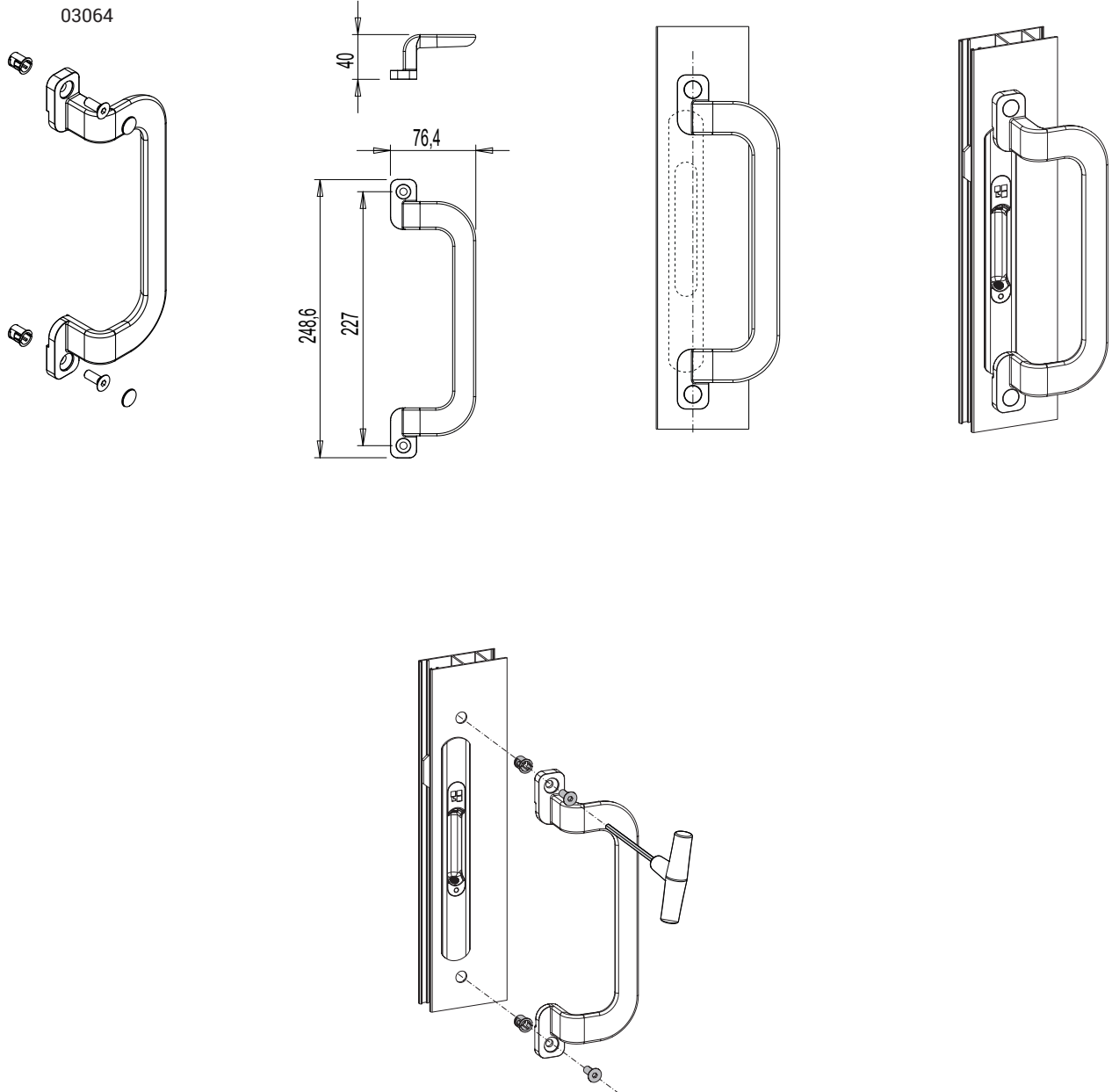

Item code	Description	Fixing	Base Raw	Anodised Elox	Painted	Trend/Gold Brass	Pieces per pack
03043	ROUNDED INTERNAL DRIVE HANDLE	centred	X		X	X	5
03050	SQUARE INTERNAL DRIVE HANDLE	centred	X		X	X	5
03064	SMALL ROUNDED INTERNAL DRIVE HANDLE	offset	X		X	X	5

INTERNAL PULL HANDLES

PRATIKA SIDE PULL HANDLE



Functions

The product is applied in combination with another Pratika recessed handle. Recommended for use on heavy aluminium sliding doors/windows to facilitate handling of the sashes.

[Online data sheet](#)



Technical Features

The Pratika side pull handle has an ergonomic grip to facilitate handling of heavy doors and windows.

This article is designed to give unrestricted access to the recess of the recessed handle.

Assembly is particularly fast, ensuring maximum durability.

Fixing is done with the same fixing plates as for the Pratika handle.

Materials

Body in extruded aluminium.

Nickel-plated brass HSCH screws

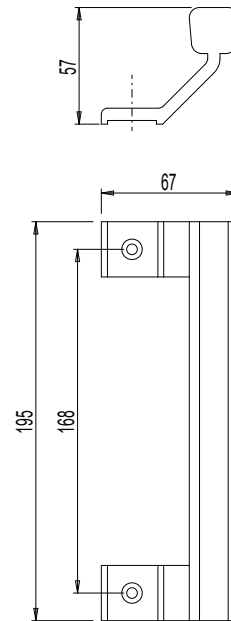
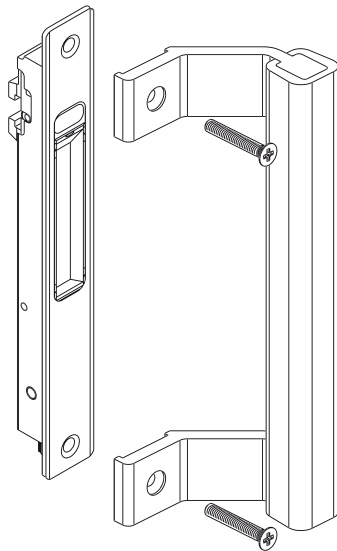

Item code	Description	Note	Base Raw	Anodised Elox	Painted	Trend/Gold Brass	Pieces per pack
03055	SIDE PULL HANDLE	only painted finishes standard RAL	X	X	X		5



CITY CREMONES

Functions

Complete system of cremones for closing and operating the internal sash of an aluminium sliding door or window.

Online data sheet



Technical Features

The City cremone allows an automatic or manual fastening mechanism depending on the needs of the window maker and end user.

The automatic fastening mechanism is typically used on sliding windows: when the sash is set ajar it closes, the pull handle can in any case remain locked in the open position.

The manual fastening mechanism is instead typically used on sliding doors: when the leaf is set ajar it does not close until the pull handle is turned into the vertical position.

With the manual function, the City Cremone is compatible with the Brio Top Security Multilock.

The CITY cremone has a Red/Green visual indicator to signal the Closed/Open status of the Sash even at a distance.

To create the fastening, the article requires a Nib (sash side) and a counter-plate (frame side).

Materials

Case and handle in die-cast aluminium

Slider and fixing plates in white zinc plated die-cast zamak

Mounting grubscrew and spring in stainless steel

Positioner in Hostaform

Pins and screws in stainless steel

The X dimension depends on the series used

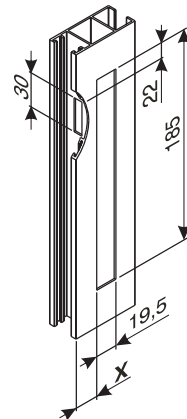

03018N

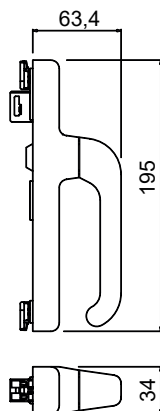
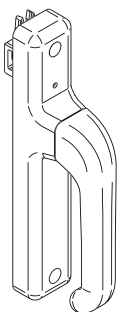

03360V

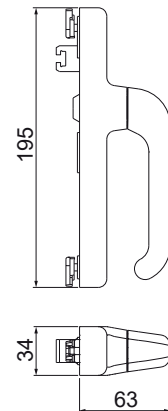

Item code	Description	Notes	Base Raw	Anodised Elox	Painted	Trend/Gold Brass	Pieces per pack
03018N	CITY CREMONE	Compatible with PRATIKA/NADA nib	X		X		5
03360V	CITY CREMONE	Compatible with BRIO EVO nib	X		X		10

CITY KEY CREMONE



Functions

Reversible cremone handle, with key lockable pull handle, for drawing the internal sash of a sliding aluminium door or window.

Online data sheet



Technical Features

The City Key cremone allows an automatic or manual fastening mechanism depending on the needs of the window maker and end user.

The automatic fastening mechanism is typically used on sliding windows: when the sash is set ajar it closes, the pull handle can in any case remain locked in the open position.

The manual fastening mechanism is instead typically used on sliding doors: when the leaf is set ajar it does not close until the pull handle is turned into the vertical position.

With the manual function, the City Cremone is compatible with the Brio Top Security Multilock.

The CITY cremone has a Red/Green visual indicator to signal the Closed/Open status of the Sash even at a distance.

To create the fastening, the article requires a Brio nib (sash side) and a counterplate (frame side).

The key cylinder on the pull handle allows the mechanism to be locked in the close position.

City Key cremones with a small nib include a "Different keys" type of cylinder (with a maximum of 50 different codes). On request it is possible to have the version with "Same keys" or "Master key".

The cylinder used has standard European dimensions. When necessary you can replace the cylinder with a commercial item available on the market.

City Key cremones include a "Same keys" type of cylinder. On request it is possible to have the version with "Different keys" (with a maximum of 50 different codes).

Materials

Case and handle in die-cast aluminium

Slider and fixing plates in white zinc plated die-cast zamak

Mounting grubscrew and spring in stainless steel

Positioner in Hostaform

Pins and screws in stainless steel

Art. 03361V

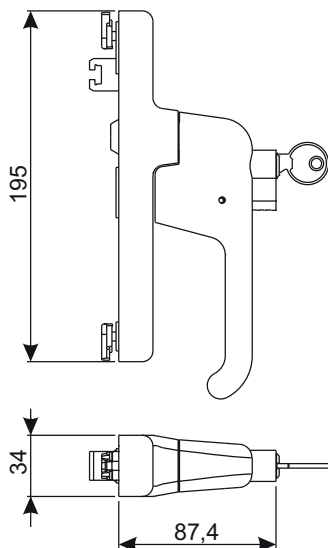

Art. 07057N

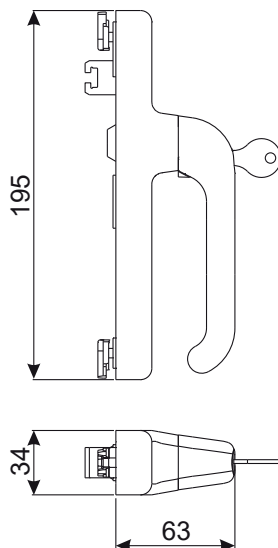

The X dimension depends on the series used

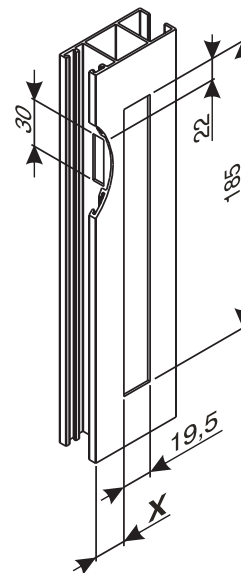

SLIDING SYSTEM CREMONES

Item code	Description	Note	Base Raw	Anodised Elox	Painted	Trend/Gold Brass	Pieces per pack
03361V	CITY KEY CREMONE W/ SMALL NIB		X		X		5
07057N	CITY KEY CREMONE				X		5

BRIO EVO BIG NIBS

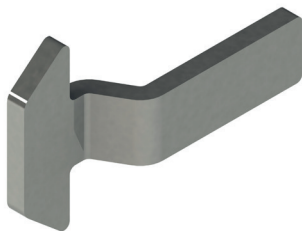

Functions

Brio Evo Big nibs, combined with a counterplate, enable making the fastening mechanism of sliding casements.

The Brio Evo Big nibs can be used in combination with the entire Brio Evo range.

Online data sheet



Technical Features

Brio Evo Big nibs are made of stainless steel and are characterized by their exceptional strength.

They are fitted with oversized heads to enable efficient use on the counterplate, and guarantee improved sealing and more range of adjustment of the lock point elements.

Brio Evo Big nibs can be combined with a great variety of Giesse counterplates (see relative section) depending on the series used.

Materials

Stainless Steel

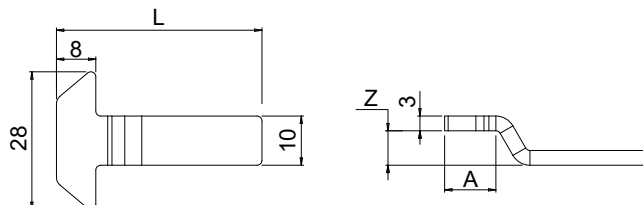

Item code	Description	L [mm]	A [mm]	Z [mm]	Base Raw	Anodised Elox	Painted	Trend/Gold Brass	Pieces per pack
02087	BRIO EVO BIG NIB	48,5	0	0	X				100
0259701	BRIO EVO BIG NIB	42	11	7	X				100
0333001	BRIO EVO BIG NIB	33	9,5	1	X				100
0333101	BRIO EVO BIG NIB	38	14,8	2,5	X				100
0333301	BRIO EVO BIG NIB	42	10	5	X				100
0453001	BRIO EVO BIG NIB	37	14,5	6	X				100
0457701	BRIO EVO BIG NIB	38,3	0	0	X				100
0457901	BRIO EVO BIG NIB	45,3	0	0	X				100
0458001	BRIO EVO BIG NIB	51	0	0	X				100
0458101	BRIO EVO BIG NIB	29	9,5	1,5	X				100
0458201	BRIO EVO BIG NIB	37,5	9,5	1,5	X				100
0458301	BRIO EVO BIG NIB	44,5	12,4	1,5	X				100
0458401	BRIO EVO BIG NIB	28,5	10,4	3,5	X				100
0458601	BRIO EVO BIG NIB	31,5	9,5	3,5	X				100
0458801	BRIO EVO BIG NIB	42	12,4	4	X				100
0458901	BRIO EVO BIG NIB	32	9	5	X				100
0459001	BRIO EVO BIG NIB	34,5	11,5	5	X				100
0459101	BRIO EVO BIG NIB	40,5	11,5	5	X				100
0459201	BRIO EVO BIG NIB	49,6	17	5	X				100
0459401	BRIO EVO BIG NIB	43	12,5	5,5	X				100
0469501	BRIO EVO BIG NIB	41	10,4	5,5	X				100
04865	BRIO EVO BIG NIB	33	9,3	1,5	X				100
0499002	BRIO EVO BIG NIB	36,3	0	0	X				100
0499101	BRIO EVO BIG NIB	44	14	3,5	X				100
0499202	BRIO EVO BIG NIB	38	14	3,5	X				100
0499902	BRIO EVO BIG NIB	46,5	14,6	2	X				100
0500401	BRIO EVO BIG NIB	42	14,6	2,5	X				100

BRIO SMALL NIBS

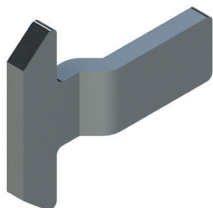

Functions

Brio Small nibs, combined with a counterplate, enable making the fastening mechanism of sliding casements.

Brio Small nibs can be used in combination with Brio mini Evo, Brio Rapid, City handles including Key versions.

Online data sheet



Technical Features

Brio Small nibs are made of stainless steel and are characterized by their exceptional strength.

They are fitted with oversized heads to enable efficient use on the counterplate, and guarantee improved sealing and more range of adjustment of the lock point elements.

Brio Small nibs can be combined with a great variety of Giesse counterplates (see relative section) depending on the series used.

Materials

Stainless Steel

Type A

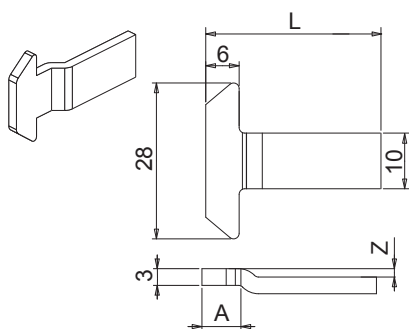

Type B

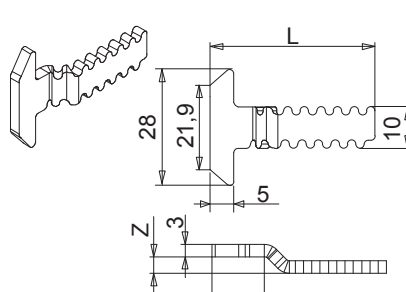

Type C

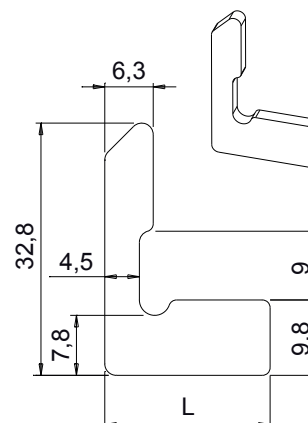

FASTENING MECHANISM COMPONENTS

Item code	Description	Drawing	L [mm]	A [mm]	Z [mm]	Base Raw	Anodised Elox	Painted	Trend/Gold Brass	Pieces per pack
02691	BRIO SMALL NIB	B	31	9	6	X				100
04923	BRIO SMALL NIB	A	38	7	6,7	X				100
04924	BRIO SMALL NIB	A	45,5	7	6,7	X				100
07373	BRIO SMALL NIB	B	34	9	3	X				100
07374	BRIO SMALL NIB	B	42	9	3	X				100
90049	BRIO SMALL NIB	A	41	10	4,5	X				100
90055	BRIO SMALL NIB	A	31	10	3	X				100
90056	BRIO SMALL NIB	A	37,2	0	0	X				100
90057	BRIO SMALL NIB	A	26	10	1,5	X				100
90058	BRIO SMALL NIB	A	39	10	4,5	X				100
90061	BRIO SMALL NIB	A	36	10	3	X				100
90062	BRIO SMALL NIB	A	34,7	0	0	X				100
90063	BRIO SMALL NIB	A	29	0	0	X				100
90064	BRIO SMALL NIB	A	35	7	1,5	X				100
90067	BRIO SMALL NIB	A	32	0	0	X				100
90068	BRIO SMALL NIB	A	32	10	1,5	X				100
90070	BRIO SMALL NIB	A	51	10	3	X				100
90075	BRIO SMALL NIB	A	42	7	1,5	X				100
90081	BRIO SMALL NIB	A	44	10	3	X				100
90082	BRIO SMALL NIB	A	38	10	3	X				100
90083	BRIO SMALL NIB	A	38	10	4,5	X				100
90084	BRIO SMALL NIB	A	50	10	4,5	X				100
90088N	BRIO SMALL NIB	C	21	0	0	X				100

BRIO ZAMAK NIBS

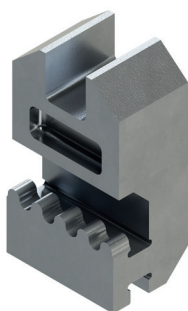

Functions

Brio zamak nibs, combined with a counterplate, enable making the fastening mechanism of sliding casements.

Recommended for those series that have the handle fitted on the shoulder of the sash profile.

Online data sheet



Technical Features

Brio zamak nibs can be used on all the handles of the Brio line in conjunction with the front counterplates.

They are fitted with oversized heads to enable efficient use on the counterplate, and guarantee improved sealing and more range of adjustment of the lock point elements.

Materials

Zinc plated zamak

Example of application

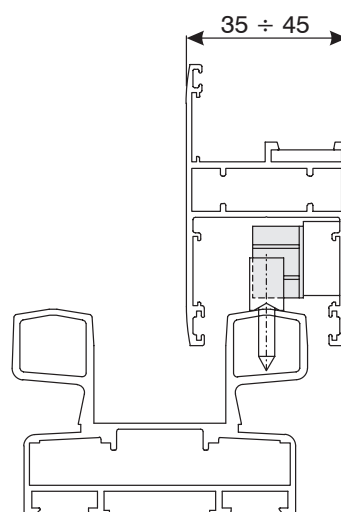
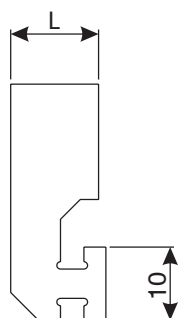
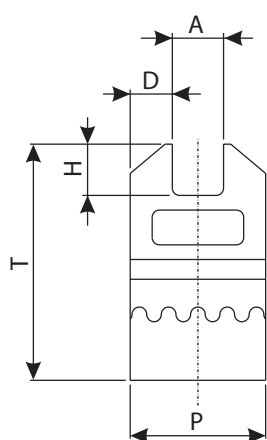

Item code	Description	A [mm]	D [mm]	P [mm]	H [mm]	T [mm]	L [mm]	Base Raw	Anodised Elox	Painted	Trend/Gold Brass	Pieces per pack
04598	BRIO NIB - ZAMAK	7,0	6,0	18,5	7,0	32,0	12,0	X				100
05011	BRIO NIB - ZAMAK	7,0	6,0	18,5	9,0	34,5	6,0	X				100
9008701	BRIO NIB - ZAMAK	7,0	4,0	15,0	5,0	32,0	10,0	X				100

PRATIKA/NADA NIBS

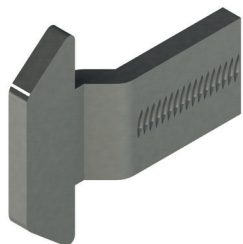

Functions

Pratika and Nada nibs, combined with a counterplate, enable making the fastening mechanism of sliding casements.

Online data sheet



Technical Features

Pratika and Nada nibs are made of stainless steel and are characterized by their exceptional strength.

They are fitted with oversized heads to enable efficient use on the counterplate, and guarantee improved sealing and more range of adjustment of the lock point elements.

Pratika and Nada nibs can be combined with a great variety of Giesse counterplates (see relative section) depending on the series used.

Materials

Stainless Steel

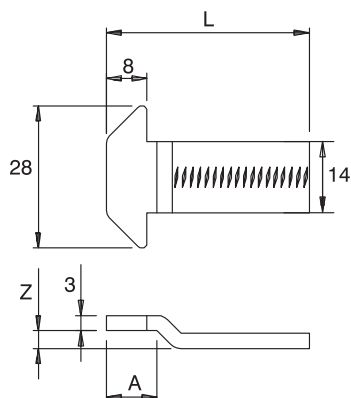

Item code	Description	L [mm]	A [mm]	Z [mm]	Base Raw	Anodised Elox	Painted	Trend/Gold Brass	Pieces per pack
02675	PRATIKA/NADA NIB	32	9,5	3,5	X				100
02676	PRATIKA/NADA NIB	38	0	0	X				100
02677	PRATIKA/NADA NIB	37,5	9,5	1,5	X				100
02679	PRATIKA/NADA NIB	44	14	3,5	X				100
02682	PRATIKA/NADA NIB	51	0	0	X				100

INSERTED COUNTERPLATES



Functions

The counterplate to be inserted, combined with a nib for a recessed handle, creates the fastener of a sliding sash.

Online data sheet



Technical Features

Inserted counterplates are to be inserted into the frame profile upright before assembly.

The counterplate is fixed to the frame by means of contrast grub screws. This type of counterplate has the advantage of being able to be height adjusted by simply loosening the grub screws and then repositioning them. They feature high tear strength as they are held by the profile.

Materials

Zamak body (GS Silver Plus/GS500)
Stainless steel grub screws

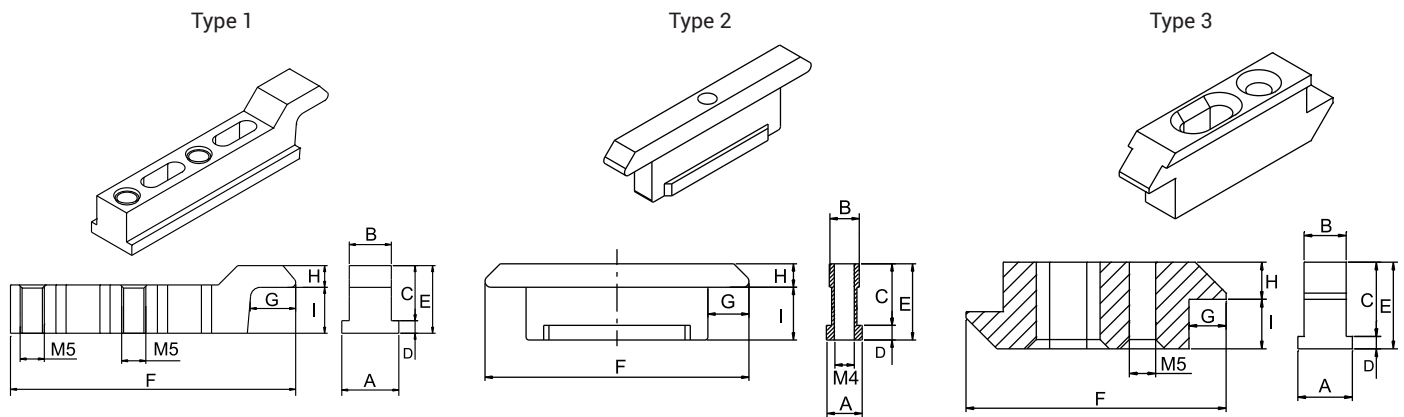

Item code	Description	Type	A	B	C	D	E	F	G	H	I	Com- patible with Brio Small nib	Compat- ible with Brio Big nib	Com- patible with Brio Zamak nib	Base Raw	Anodised Elox	Painted	Trend/Gold Brass	Pieces per pack
03326	INSERTED COUNTERPLATE	2	6	5	10,5	2,5	13	45	7	4	9	YES	YES	NO	X				100
0332701	INSERTED COUNTERPLATE	2	10	8	10,5	2,5	13	45	7	4	9	YES	YES	NO	X				100
0332801	INSERTED COUNTERPLATE	2	8	6	10,5	2,5	13	45	7	4	9	YES	YES	NO	X				100
03930	INSERTED COUNTERPLATE	3	10,5	8	11	3	14	42	6	4	10	YES	YES	NO	X				30
03947	INSERTED COUNTERPLATE	1	12,1	9,4	11,7	2,3	14	59	9,3	4,5	9,5	YES	YES	NO	X				30
04685	INSERTED COUNTERPLATE	1	11,8	8,7	11,4	2,6	14	59	9,3	4,5	9,5	YES	YES	NO	X				100
9003001	INSERTED COUNTERPLATE	3	10,5	8	11	3	14	42	6	4	10	YES	YES	NO	X				100
9003301	INSERTED COUNTERPLATE	3	10	9	11	2	13	33	5,5	5,5	7,5	YES		NO	X				100
9003601	INSERTED COUNTERPLATE	3	7,8	6,8	9	1,5	10,5	42	6	4	6,5	YES		NO	X				100
90039	INSERTED COUNTERPLATE	3	8,8	6,8	12	2	14	42	6	6	8	YES		NO	X				100
90040	INSERTED COUNTERPLATE	1	12,1	8,7	11,4	2,6	14	59	9,3	4,5	9,5	YES	YES	NO	X				100
90044N	INSERTED COUNTERPLATE	1	12,1	9,4	11,7	2,3	14	59	9,3	4,5	9,5	YES	YES	NO	X				100
90079	INSERTED COUNTERPLATE	1	8	7	11	3,5	14,5	37	5	4,5	10	YES	YES	NO	X				100
9008001	INSERTED COUNTERPLATE	1	10	7	10,5	3,5	14	35	9,5	4,5	9,5	YES	YES	NO	X				100

FRONT-MOUNTED COUNTERPLATES



Functions

The front application counterplate combined with a nib for a recessed handle creates the fastener of a sliding sash.

Online data sheet



Technical Features

The front-mounting counterplates are fitted with the frame already assembled, on the frame upright usually with self-tapping screws.

This type of counterplate has the advantage of being able to be height adjusted thanks to the slots for accommodating screws, by simply loosening them and then repositioning the counterplate.

Available in different versions depending on the profile on which they are to be mounted.

For Type 1 counterplates there is also a cosmetic cover and an 8 mm shim.

Materials

Zamak body (GS Silver Plus/GS500)

Stainless steel fixing screws

Type 1

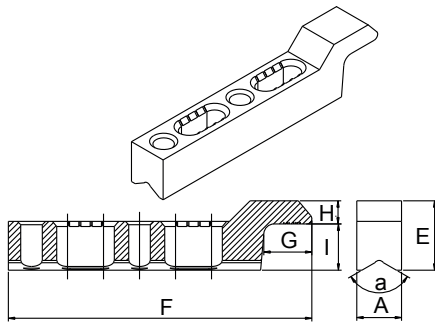

Type 2

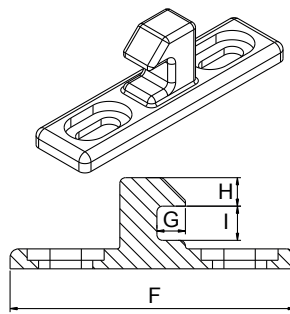

Type 3

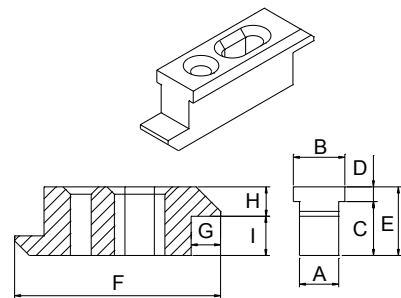

Item code	Description	Type	Shims	A	B	C	D	E	F	G	H	I	a°	Compatible with Brio Small nib	Compatible with Brio Big nib	Compatible with Brio Zamak nib	Base Raw	Anodised Elox	Painted	Trend/Gold Brass	Pieces per pack
03337	FRONT-MOUNTED COUNTERPLATE	1	no	8,7	-	-	-	13,5	59	9,3	4,5	9	120°	YES	YES	YES	X				100
03338	FRONT-MOUNTED COUNTERPLATE	1	no	8,7	-	-	-	13,5	59	9,3	4,5	9	120°	YES	YES	YES	X				100
03389	FRONT-MOUNTED COUNTERPLATE	1	≤ 12.5 mm	8,7	-	-	-	13,5	59	9,3	-	-	120°	YES	YES	YES	X				20
9002901	FRONT-MOUNTED COUNTERPLATE	2	no	13	7,5	12,5	3,5	16	50	5	4	7	-	YES	NO	NO	X				100
90032	FRONT-MOUNTED COUNTERPLATE	3	no	6,8	8,8	2	12	14	42	6	6	8	-	YES	NO	NO	X				100
9003401	FRONT-MOUNTED COUNTERPLATE	3	no	8	10,5	3	11	14	42	6	6	8	-	YES	NO	NO	X				100
9003801	FRONT-MOUNTED COUNTERPLATE	1	no	10	-	-	-	14	43	5	6	8	120°	YES	NO	NO	X				100
9004201	FRONT-MOUNTED COUNTERPLATE	1	no	8,2	-	-	-	18,5	42	6	6	12,5	150°	YES	YES	YES	X				100
90047	FRONT-MOUNTED COUNTERPLATE	1	no	12,1	9,4	11,7	2,3	14	59	9,3	4,5	9,5	-	YES	YES	YES	X				100
90085	FRONT-MOUNTED COUNTERPLATE	1	no	8	6,2	11	3,5	14,5	37	5,1	4,5	10	-	YES	YES	YES	X				100



COUNTERPLATES FOR MILLED RAIL

Functions

The front application counterplate combined with a nib for a recessed handle creates the fastener of a sliding sash.

Online data sheet



Technical Features

The counterplate is applied on the frame of a sliding casement by means of the self-threading screws supplied.

It is specific to those profiles that require the rail on the cross beam of the frame.

The slots on the counterplate body enable height adjustment in order to correctly position it for a better grip on the nib.

The base of the counterplate provides for an angle of 150° so that it can be applied on frames with rail and frames with flat slot.

The counterplate is compatible with Giesse Brio and Pratika line nibs.

Available in two versions without (type 1) and with shutter (type 2).

According to need, the version without a shutter can be combined with polyamide shims so that it can be moved away from the frame.

Materials

Corrosion-proof stainless steel counterplate
Zamak shutter (GS Silver Plus/GS500)
Stainless steel screws

Type 1

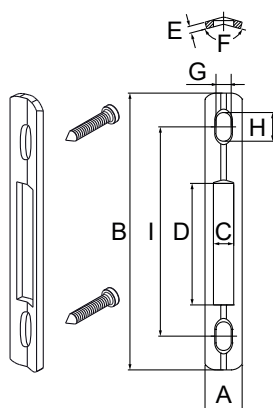

Type 2

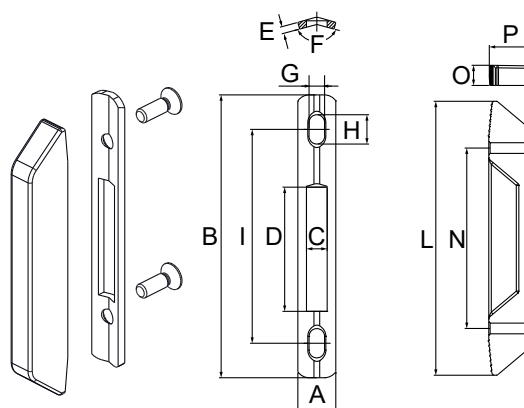

Item code	Description	Type	A	B	C	D	E	F	G	H	I	L	N	O	P	Com- pat- ible with Brio Small nib	Com- pat- ible with Brio Big nib	Com- pat- ible with Brio Zam- ak nib	Base Raw	Anodised Elox	Painted	Trend/Gold Brass	Pieces per pack
03336	FRONT-MOUNTED COUNTERPLATE	1	11	82	6	36	2	150°	4,5	8,5	62	-	-	-	-	YES	YES	NO	X			100	
03336L	FRONT-MOUNTED COUNTERPLATE	1	16	82	10	36	2	150°	5	8,5	54	-	-	-	-	YES	YES	NO	X			100	
04688	FRONT-MOUNTED COUNTER- PLATE+SHUTTER	2	11	82	6	36	2	150°	6	6	54	80	54	8	9	YES	YES	NO	X			100	
04690	FRONT-MOUNTED COUNTER- PLATE+SHUTTER	2	16	82	10	36	2	150°	5	8,5	54	80	54	12	9	YES	YES	NO	X			100	
90035	COUNTERPLATE + SHUTTER	2	11	82	6	36	2	150°	6	6	54	82	54	6	17	YES	YES	NO	X			100	
90041N	FRONT-MOUNTED COUNTERPLATE	1	11	82	6	36	2	150°	4,5	8,5	62	-	-	-	-	YES	YES	NO	X			100	
90043	COUNTERPLATE + SHUTTER	2	11	82	6	36	2	150°	6	6	54	82	54	8	14	YES	YES	NO	X			100	

VARIOUS COUNTERPLATES



Functions

The counterplate, combined with a nib for a recessed handle, creates the fastener of a sliding sash.

Online data sheet



Technical Features

These counterplates are difficult to classify as they are specific for sliding profiles (in particular frames) that have unique characteristics. For the application it is advisable to see Giesse Where Used. They are fixed depending on the version or by self-threading screws, or by pre-assembled grub screws.

Materials

Zamak with GS Silver Plus finish
Screws and grub screws in stainless steel

0299101

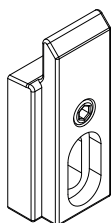

0469401

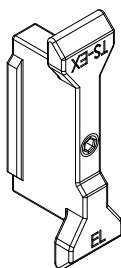

04922

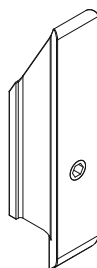

0737201

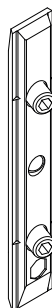

0737801

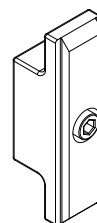

9007601

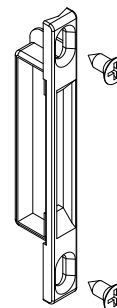

Item code	Description	Fixing	Base Raw	Anodised Elox	Painted	Trend/Gold Brass	Pieces per pack
0299101	INSERTED COUNTERPLATE	grub screw	X				100
0469401	INSERTED COUNTERPLATE	grub screw	X				100
04922	INSERTED COUNTERPLATE	grub screw	X				100
0737201	FRONT-MOUNTED COUNTERPLATE	grub screws	X				100
0737801	INSERTED COUNTERPLATE	grub screw	X				100
9007601	COUNTERPLATE	self - threading	X				100

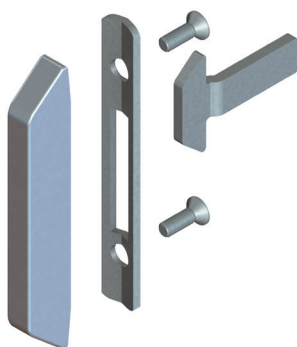

BRIO EVO COUPLING KIT

Functions

Brio coupling kits comprise the components necessary for creating a fastening mechanism on aluminium sliding windows or doors. They can be used in combination with the full Brio range (Brio Evo, Brio Mini Evo, Brio Evo Rapid, City Cremona handles, including Key versions).

Online data sheet



Technical Features

The coupling kits are composed of nib and a counterplate, packed together so that the window maker has everything required for making the fastening mechanism for the sliding door or window.

The nib is available in stainless steel and zamak.

The length and anchoring varies depending on the profile to be used.

The counterplate is available in stainless steel or zamak.

Depending on the frame in which it is to be fitted, it is available in the following versions:

A – insert

B – front mounting

C – front mounting with milled rail

D – front mounting with milled rail and shutter

E – miscellaneous

Materials

Stainless steel nibs

Counterplates: A – zamak counterplate and stainless steel grub screws

B – zamak counterplate and stainless steel screws

C – counterplate and screws in stainless steel

D – shutter in zinc plated zamak and counterplate and screws in stainless steel

E – zamak

Example of Brio Evo coupling kit

1 - Nib

2 - Counterplate (variable depending on the product)

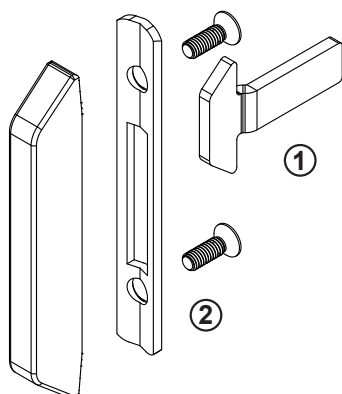

Possible counterplates

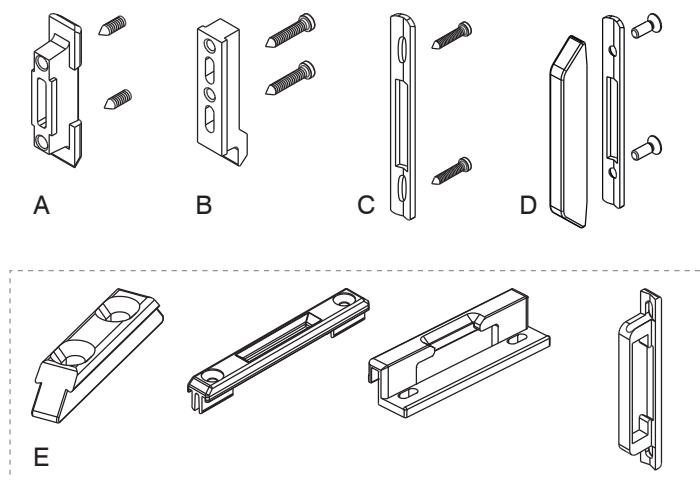

FASTENING MECHANISM COMPONENTS

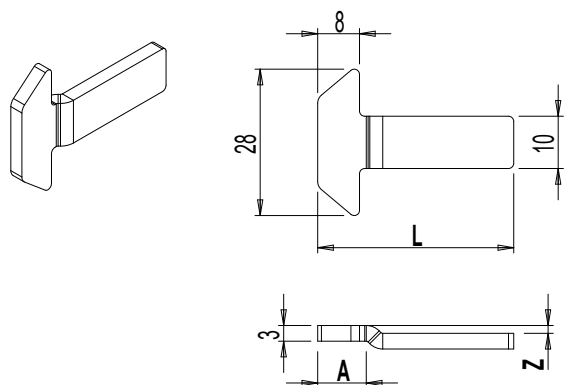

Item code	Description	Nib	L	A	Z	Counterplate	Counterplate type	Base Raw	Anodised Elox	Painted	Trend/Gold Brass	Pieces per pack
0078902	BRIO EVO COUPLING KIT	0333301	33	9,5	1	9007601	E	X				20
0080201	BRIO EVO COUPLING KIT	0458901	36,3	0	0	90032	A	X				20
0488801	BRIO EVO COUPLING KIT	0457701	38,3	0	0	specific	C/D	X				20
0489101	BRIO EVO COUPLING KIT	0458001	51	0	0	90047	B	X				20
0489301	BRIO EVO COUPLING KIT		50	14	3,5	90047	B	X				20
0489401	BRIO EVO COUPLING KIT	0458201	37,5	9,5	1,5	specific	C/D	X				20
0489501	BRIO EVO COUPLING KIT	0458301	44,5	9,5	1,5	03337	B	X				20
0489601	BRIO EVO COUPLING KIT	0499101	44	14	3,5	specific	C/D	X				20
0489701	BRIO EVO COUPLING KIT	0459401	43	12,5	5,5	specific	C/D	X				20
0489901	BRIO EVO COUPLING KIT	0458201	37,5	9,5	1,5	specific	C/D	X				20
0490201	BRIO EVO COUPLING KIT	0458901	32	9	5	03336L	C/D	X				20
04902L1	BRIO EVO COUPLING KIT	0458901	32	9	5	03336L	C/D	X				20
0490301	BRIO EVO COUPLING KIT	0458901	32	9	5	04687	A	X				20
0490401	BRIO EVO COUPLING KIT	0458601	32,2	9,5	3,5	04688	C/D	X				20
0490501	BRIO EVO COUPLING KIT	0458601	32,2	9,5	3,5	specific	C/D	X				20
0491001	BRIO EVO COUPLING KIT	0458201	37,5	9,5	1,5	03947	A	X				20
04912L1	BRIO EVO COUPLING KIT	0459501	30	11	8	04690	C/D	X				20
0491301	BRIO EVO COUPLING KIT	0458401	28,5	10,4	3,5	specific	C/D	X				20
0491601	BRIO EVO COUPLING KIT	0458101	29	9,5	1,5	specific	C/D	X				20
0491701	BRIO EVO COUPLING KIT	0499002	36,3	0	0	90047	B	X				20
0491902	BRIO EVO COUPLING KIT	0500401	42	14,8	2,5	90076	E	X				20
0492001	BRIO EVO COUPLING KIT	0459201	50	17	5	90047	B	X				20
0492101	BRIO EVO COUPLING KIT	0499202	38	14	3,5	specific	C/D	X				20
0496601	BRIO EVO COUPLING KIT	0499002	36,3	0	0	specific	C/D	X				20
04994L1	BRIO EVO COUPLING KIT		32	12,5	8	04690	C/D	X				20
0714102	BRIO EVO-CITY COUPLING KIT MONACO TOP LINE	0459001	36,3	0	0	9007601	E	X				20
0714202	BRIO EVO-CITY COUPLING KIT MEDITERRANEA M3	0499202	38	13,7	3,5	9007601	E	X				20

BRIO COUPLING KIT



Functions

Brio coupling kits comprise the components necessary for creating a fastening mechanism on aluminium sliding windows or doors. They can be used in combination with the full Brio Evo range (Rapid, Mini, City, including the Key versions).

Online data sheet



Technical Features

The coupling kits are composed of nib and a counterplate, packed together so that the window maker has everything required for making the fastening mechanism for the sliding door or window.

Front-mounted counterplate

Brio coupling kits can be fitted on:

- Brio Evo
- Brio Mini Evo
- Brio Rapid Evo
- City Cremone
- City Key Cremone

Materials

Nib and Counterplate in Zamak
Stainless steel screws

0500201

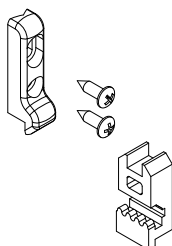

05005

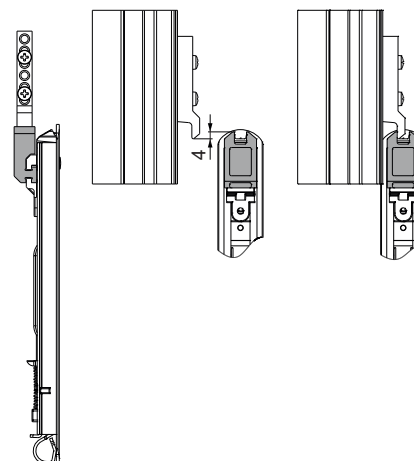
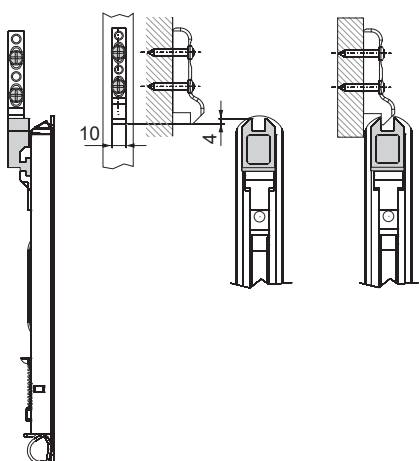
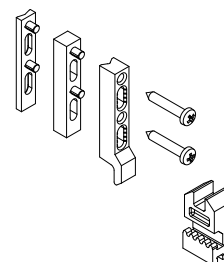

Item code	Description	Nib	Counterplate	Base Raw	Anodised Elox	Painted	Trend/Gold Brass	Pieces per pack
0500201	BRIO PLUS/BRIO MINI COUPLING KIT	90087N	90038	X				20
05005	BRIO PLUS/BRIO MINI COUPLING KIT	04598	03337	X				20

PRATIKA/NADA COUPLING KIT



Functions

The coupling kits comprise the components necessary for creating a fastening mechanism on aluminium sliding windows or doors. They can be used in combination with the whole PRATIKA range (including the key version) and NADA range.

Online data sheet



Technical Features

The coupling kits are composed of nib and a counterplate, packed together so that the window maker has everything required for making the fastening mechanism for the sliding door or window.

The nib is made of stainless steel and is available with various lengths and anchorings based on the series used.

The counterplate is available in stainless steel or zamak.

Depending on the frame in which it is to be fitted, it is available in the following versions:

A – insert

B – front application

C – front mounting with milled rail

D – front mounting with milled rail and shutter

Pratika and Nada coupling kits can be applied to:

- Pratika
- Pratika Duo Key
- Pratika Duo
- Nada
- City Cremone

Materials

Stainless steel nibs

Counterplates:

A – zamak counterplate and stainless steel grub screws

B – zamak counterplate and stainless steel screws

C – counterplate and screws in stainless steel

D – shutter in zinc plated zamak and counterplate and screws in stainless steel

- 1 - Nib
2 - Counterplate (variable depending on the product)

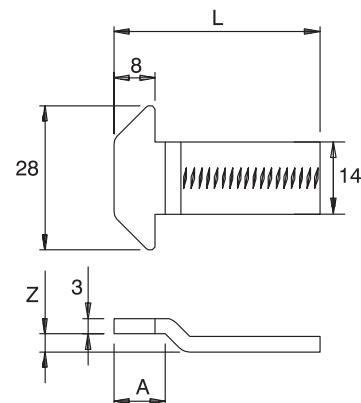
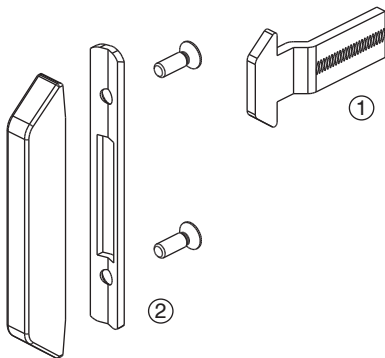

Possible counterplates

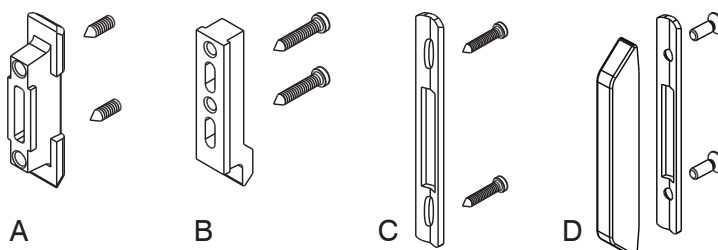

FASTENING MECHANISM COMPONENTS

Item code	Description	Nib	L	A	Z	Counterplate	Counterplate type	Base Raw	Anodised Elox	Painted	Trend/Gold Brass	Pieces per pack
02149	PRATIKA/NADA COUPLING KIT	02675	32	9,5	3,5	Specific	C	X				20
03063L	PRATIKA/NADA COUPLING KIT	02674	30	11	8	04690	C	X				20
03068	PRATIKA/NADA COUPLING KIT	02675	32	9,5	3,5	04688	C	X				20
03069L	PRATIKA/NADA COUPLING KIT	02686	32	12,5	8	04690	C	X				20
03082	PRATIKA/NADA COUPLING KIT	02676	38	0	0	Specific	C	X				20
03083	PRATIKA/NADA COUPLING KIT	02677	37,5	9,5	1,5	Specific	C	X				20
03084	PRATIKA/NADA COUPLING KIT	02678	44,5	9,5	1,5	Specific	C	X				20
03085	PRATIKA/NADA COUPLING KIT	02679	44	14	3,5	Specific	C	X				20
03087	PRATIKA/NADA COUPLING KIT	02680	29	9,5	1,5	Specific	C	X				20
03088	PRATIKA/NADA COUPLING KIT	02681	32	9,5	5	04688	C	X				20
03088L	PRATIKA/NADA COUPLING KIT	02681	32	9,5	5	03336L	C	X				20
03092	PRATIKA/NADA COUPLING KIT	02683	50	14	3,5	90047	B	X				20
03098	PRATIKA/NADA COUPLING KIT	02678	44,5	9,5	1,5	03337	B	X				20
03346	NIB HOLDER FOR STEM SIZE 10 mm							X				50



DELTA PLUS LUG HANDLE

Functions

Lug handle for the lock on the central upright of a door or a sliding window made of aluminium.

Online data sheet



Technical Features

The Delta Plus handle fixing system is accomplished using expansion dowels. The machining required on the profile comprises two simple 10 mm holes and one 9 mm hole which is needed for the pin to pass through.

The stroke of the lock pin is = 15 mm.

The Delta Plus handle has a selector that locks the main lug in the closed position.

This function prevents unintentional opening of the handle, improving security. When the selector is in the block position you cannot move the main open/close lug.

Materials

Handle body made of die-cast aluminium

Lugs, side guards and shims made of polyamide with glass fibre

Zinc-coated steel pin

Protective caps for fixing screws made of rubber

Stainless steel fixing screws

Fixing inserts made of zinc plated steel

Overall dimensions

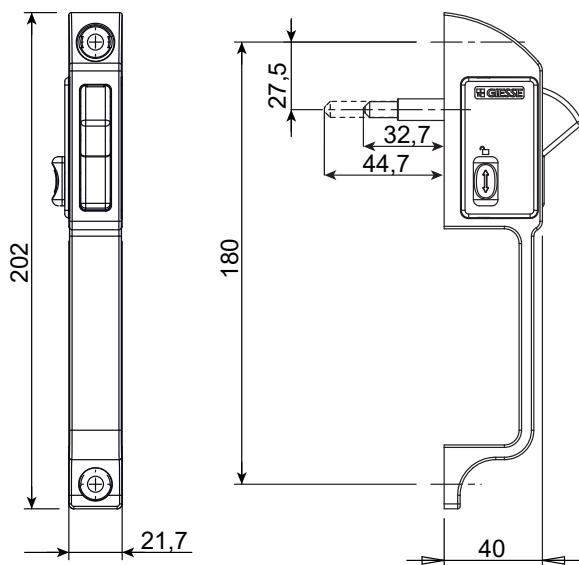

Handle assembly

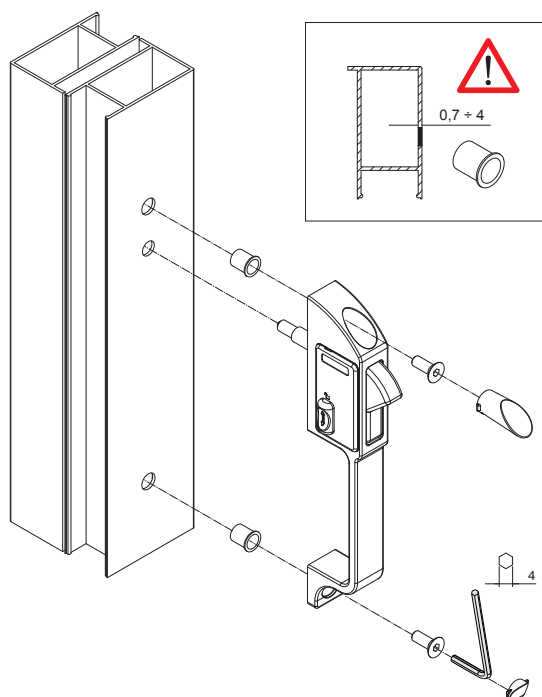

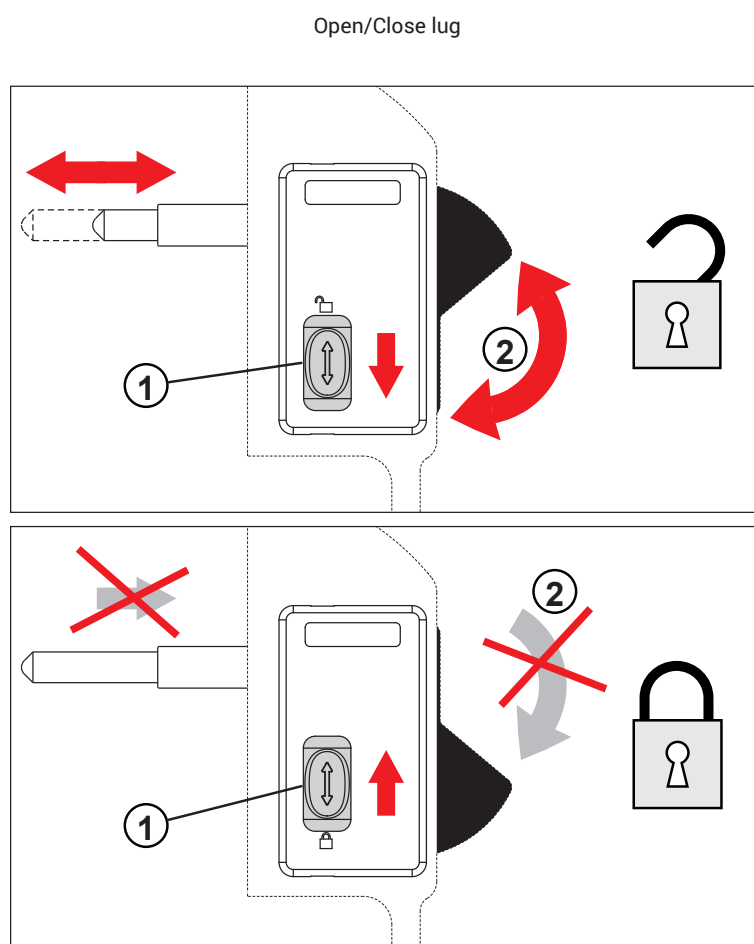
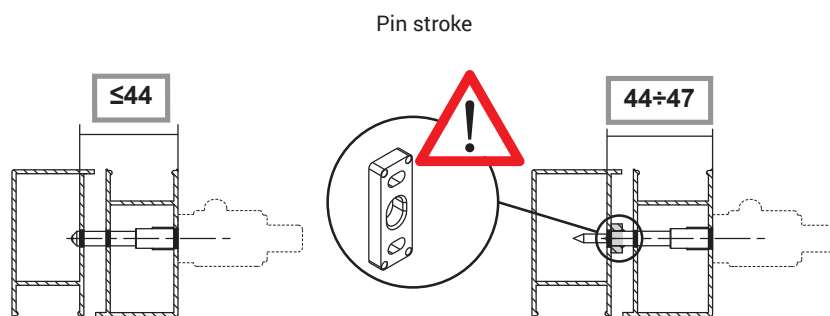
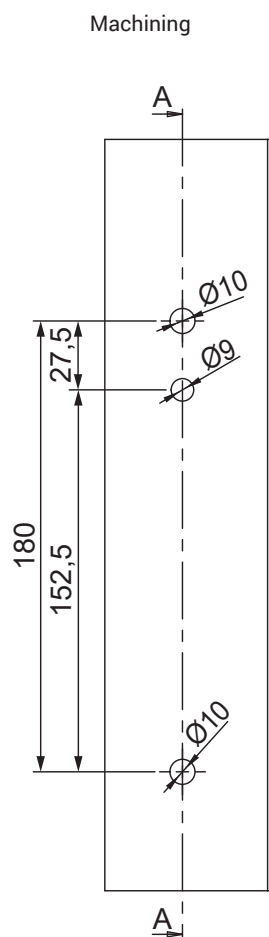

Item code	Description	Pin length (sash open) mm	Pin length (sash closed) mm	Pin stroke mm	Base Raw	Anodised Elox	Painted	Trend/Gold Brass	Pieces per pack
02701	DELTA PLUS LUG HANDLE	32,7	47,7	15	X		X		20

FRONT APPLICATION HANDLES

BUTTERFLY HANDLE



Functions

External carry handle, with snap coupling, to be fitted laterally on aluminium sliding doors.

Online data sheet



Technical Features

The handle is disengaged and the sash opened by simply pressing on the side. Available with closing Block H of 106 and 181 mm (by turning the special device) or without block H = 106 mm.

Materials

Handle body made of extruded aluminium
Casing, striker and shim in black polyamide
Spring in zinc plated steel

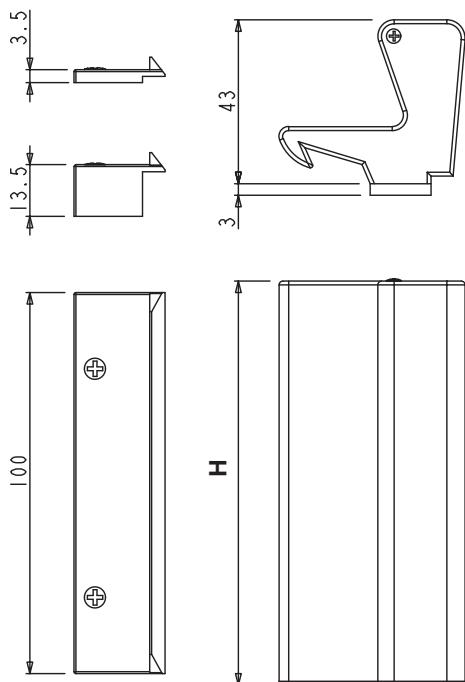

Item code	Description	Closing block	Handle height H	Base Raw	Anodised Elox	Painted	Trend/Gold Brass	Pieces per pack
03172	BUTTERFLY HANDLE	NO	106	X	X	X		20
03177	BUTTERFLY HANDLE	YES	181	X	X	X		20



MISMO

Functions

The Mismo fastening element is composed of a nib carrier on which is housed the nib that, engaging in the corresponding counterplate, makes a locking point.

Online data sheet



Technical Features

The nib is secured in the nib-holder with the grub screw. In the Mismo multilock the number of fastening components can be varied according to the desired grade of security of the casement. The nib-holders are interconnected with a rod 15/20 with an 8 mm diameter hole.

Materials

Housing in Zamak
Mounting grub screw and nib in stainless steel

A=Nib (03345) B=Nib carrier (03340)

C= ASIA PLUS 0-90 (01401 + 02025)

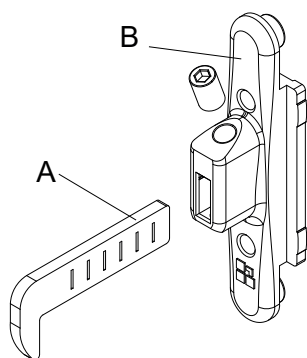

Dimensions

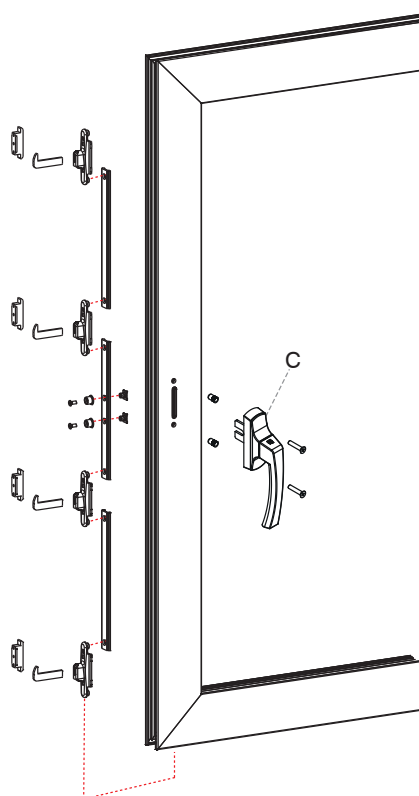
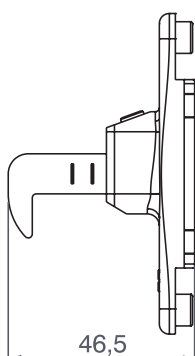

Item code	Description	Note	Base Raw	Anodised Elox	Painted	Trend/Gold Brass	Pieces per pack
0334001	MISMO NIB HOLDER		X				50
03345	MISMO STRAIGHT NIB	2 mm	X				50

BRIO TOP SECURITY

Functions

Multi-lock for slider operated by a recessed handle, which allows closing with 2 (window) or 3 (door) locking points.

Online data sheet

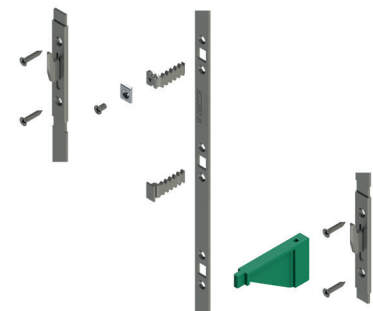

Technical Features

The BRIO TOP SECURITY multi-lock is fitted on sashes with 90° cuts in which the recessed handle is applied inside the tubular section.

The hardware is made of stainless steel to guarantee optimum resistance to wear. The opening and closing movement is transmitted by the recessed handle to the hardware by means of a zamak connector (versions available both for insertion and for screwing in).

The lock points engage with the counterplates on the frame (not supplied).

Brio Top Security comprises three fastening nibs and is applied to the profile at the front using self-tapping screws, the machining is simple and fast thanks to the use of a drilling template.

Not suitable for use on insulating profiles.

For the centring of the hardware use the template 02612.

Materials

Nib, fixing plate, multi locking rod and drive element in stainless steel.

Fixing for connection elements in zinc plated zamak.

Polyamide positioning template.

Version A: Connection to nib

Version B: Connection to nib screwed in

Centring template

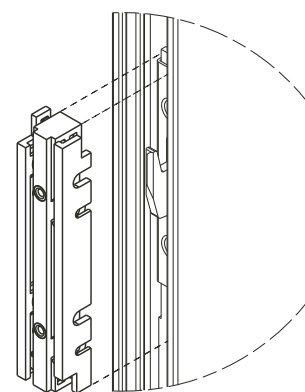
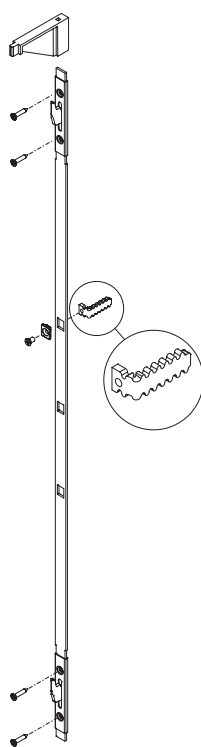
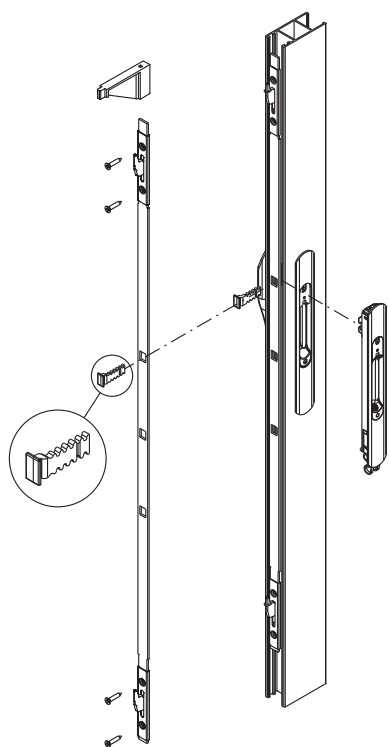

Version C: Connection to Cremone and Drive rod (04109)

Version C: Connection to Brio Evo

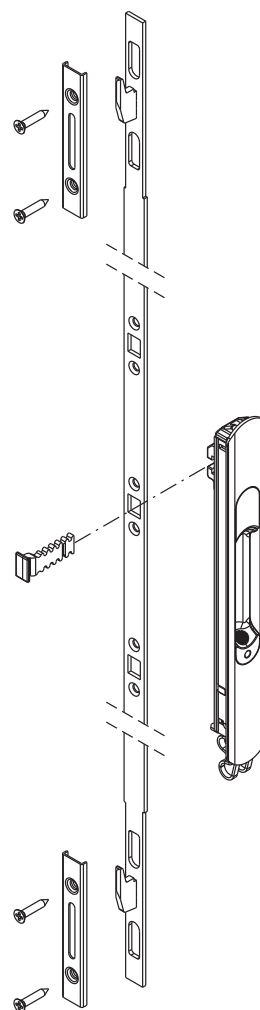
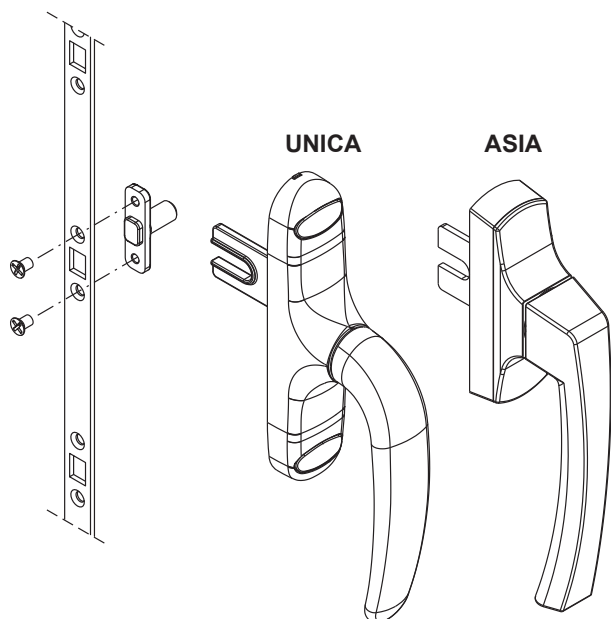

04109 Drive rod for Top Security multilock

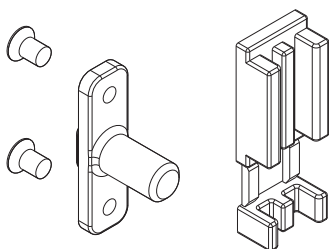

Item code	Description	Sash height	Locking points	Base Raw	Anodised Elox	Painted	Trend/Gold Brass	Pieces per pack
0373301	TOP SECURITY BRIO MULTILOCK2P	800 - 1600 mm	2	X				10
0373401	TOP SECURITY BRIO MULTILOCK 3P	> 1600 mm	3	X				10
02612	BRIO MULTILOCK CENTRING TEMPLATE			X				5
04109	DRIVE ROD FOR TOP SECURITY MULTILOCK			X				20

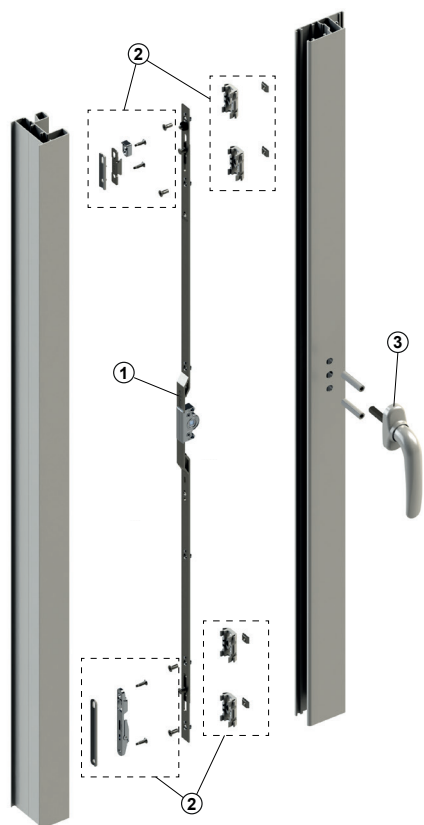

CHAMPION PLUS MULTILOCK

Functions

Multilocking system, for aluminium sliding doors and windows, that can be operated with a single mechanism (window handle or recess handle).

Technical Features

Champion Plus is a locking system consisting of 3 different components:

1. Standard fastening rod or fastening rod with micro-ventilation
2. Fixing kit for standard fastening rods or fastening rods with micro-ventilation
3. Mechanisms

Depending on the type of sliding system used and the size of the sash, the appropriate fastening rod and fixing kit must be selected.

CHAMPION PLUS - VERSION WITH MICRO-VENTILATION

1. Closed window

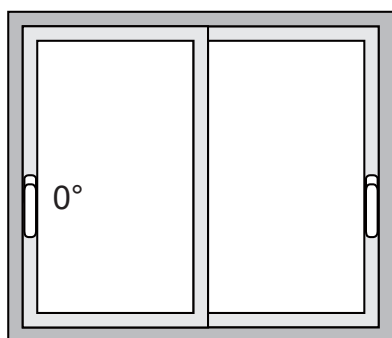

2. Opening window

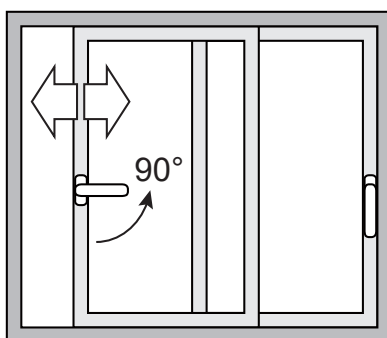

3. Window in micro-ventilation position

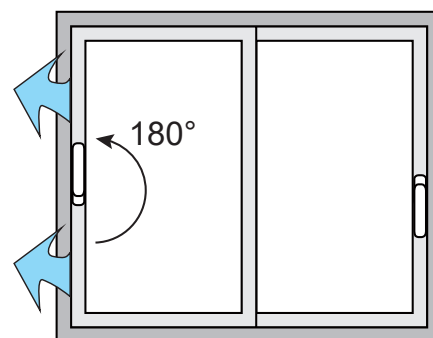

CHAMPION PLUS - STANDARD VERSION (WITHOUT MICRO-VENTILATION)

1. Closed window

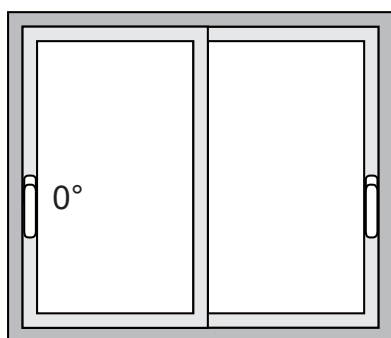

2. Opening window

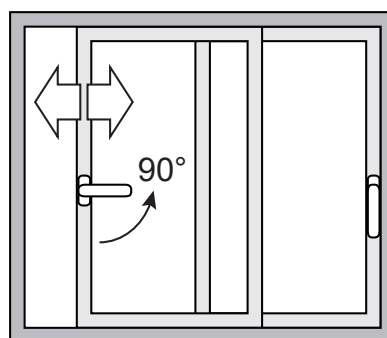



CHAMPION PLUS FASTENING RODS WITH MICRO-VENTILATION

Functions

Rods that provide a 2- or 3-point multi-lock in an aluminium window or sliding door.

Online data sheet



Technical Features

The Champion Plus fastening rods with micro-ventilation are available with two different backsets: 7.5 and 15 mm in 3 different lengths: 600 (2 points), 1000 (2 points) and 1600 mm (3 points).

A version with key is also available for the 15 mm backset, with a length of 1600 mm (3 points).

These rods, if applied in combination with the appropriate fixing kit, allow for a position in which the sash moves away by a few millimeters from the closed position, allowing for air recirculation/passage (micro-ventilation).

These multi-locks have 3 operating positions:

- 1) 0° CLOSED SASH
- 2) 90° OPEN SASH
- 3) 180° MICRO-VENTILATED SASH

The 180° position can be inhibited by using a screw that limits the rotation of the mechanism to the 90° position only (open sash).

In this case, the micro-ventilation function will be excluded.

All CHAMPION PLUS rods WITH MICRO-VENTILATION are compatible with all window handles having a 7 mm square pin and fixing screws with 43 mm c/c distance.

Materials

Zinc-plated steel lift-proof pin and rods
Box for rotor and nibs in Stainless Steel

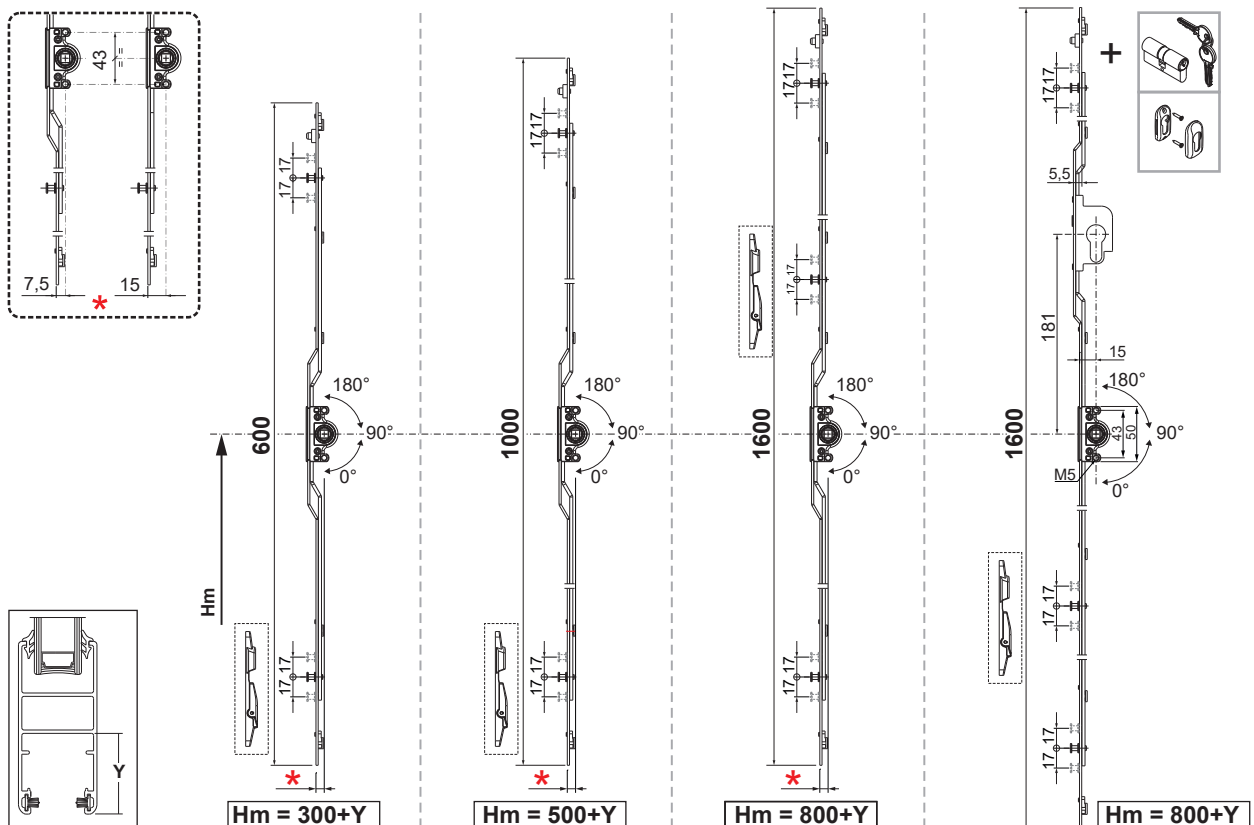

CHAMPION PLUS MULTILOCK

Item code	Description	Backset	Lock	Incorrect Movement Safety Device Compatibility	Length	Window handle height	Locking points	Base Raw	Anodised Elox	Painted	Trend/Gold Brass	Pieces per pack
06334	CHAMPION PLUS ROD WITH MICRO-VENTILATION	7,5	NO	NO	600	> 300 + Y	2	X				4
06335	CHAMPION PLUS ROD WITH MICRO-VENTILATION	7,5	NO	NO	1000	> 500 + Y	2	X				4
06336	CHAMPION PLUS ROD WITH MICRO-VENTILATION	7,5	NO	NO	1600	> 800 + Y	3	X				4
06337	CHAMPION PLUS ROD WITH MICRO-VENTILATION	15	NO	NO	600	> 300 + Y	2	X				4
06338	CHAMPION PLUS ROD WITH MICRO-VENTILATION	15	NO	NO	1000	> 500 + Y	2	X				4
06339	CHAMPION PLUS ROD WITH MICRO-VENTILATION	15	NO	NO	1600	> 800 + Y	3	X				4
06340	CHAMPION PLUS ROD WITH MICRO-VENTILATION	15	YES	NO	1600	> 800 + Y	3	X				4

CHAMPION PLUS FIXING KIT WITH MICRO-VENTILATION



Functions

The fixing kit is necessary to correctly and durably fix a Champion rod with micro-ventilation in a specific aluminium sliding system and to obtain the micro-air circulation function.

Online data sheet



Technical Features

The Champion Plus fixing kit with micro-ventilation is available in two versions:

- for 2 point multi-lock
- for 3 point multi-lock

The Champion Plus fixing kit with micro-ventilation usually includes all those components necessary to apply the fastening rod in a specific aluminium sliding system.

These kits therefore generally include:

- Shims to adapt the rod to the sash profile
- Frame counterplates
- Frame micro-ventilation counterplate
- Frame counterplate adjustment shims
- Lift-proof component
- Fixing screws
- Window handle spacer tubes

By acting on the grub screw located at the front of the counterplate, it is possible to adjust the amount of micro-ventilation from a sash-frame crossing of +3 mm to +6 mm.

The rod adjustment shims snap into place, facilitating hardware installation operations.

Depending on the sliding system used, these adapters provide different fixing systems:

- direct to the profile, in which the screw grips directly in the sash profile
- with expansion (patented by Giesse) in which the adapter expands and anchors to the sash profile without the need for drilling

Materials

Shims for adapting the rod to the profile, counterplate shims and window handle spacers of grey polyamide

Screws for fixing rod to profile in stainless steel

Frame counterplate made of zinc plated steel

Micro-ventilation counterplate, anti-lift component and retractor (where applicable) made of die-cast zamak

Micro-ventilation counterplate

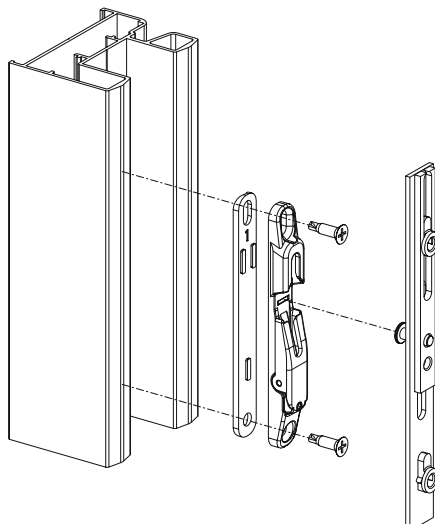

CHAMPION PLUS MULTILOCK

Micro-ventilation

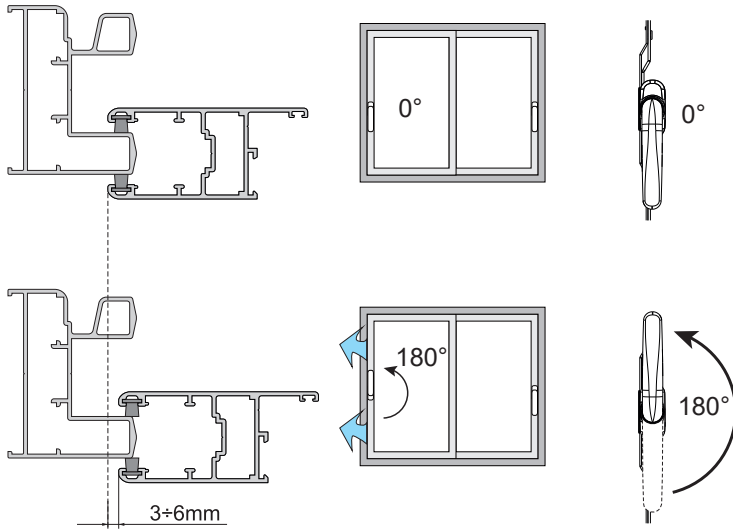

Micro-ventilation adjustment

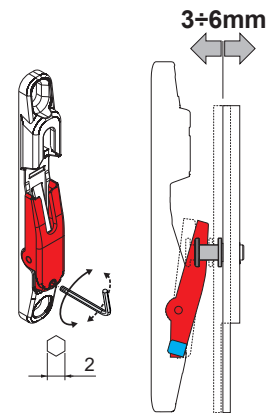

Type 1

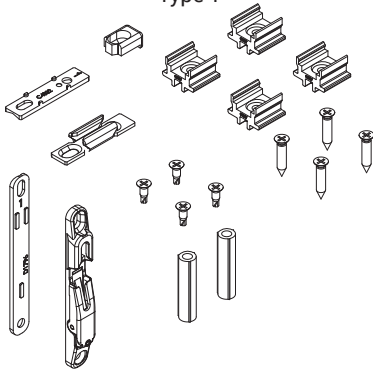

Type 2

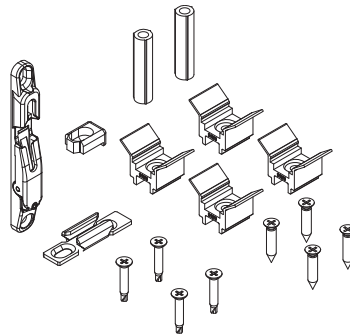

Type 3

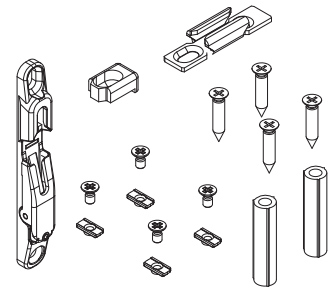

Type 4

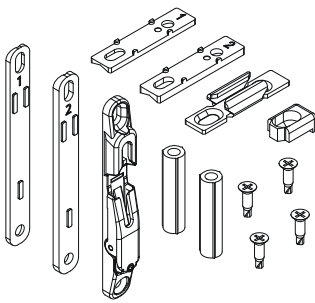

Type 5

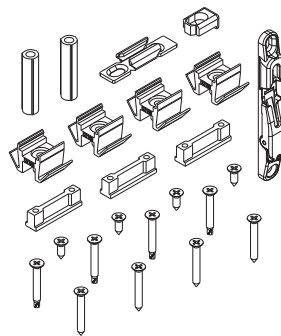

Type 6

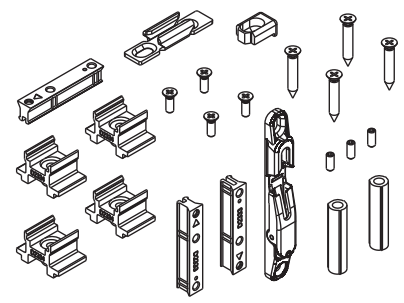

Type 7

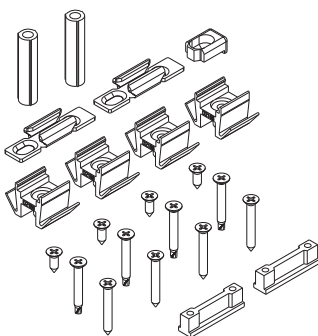

06370

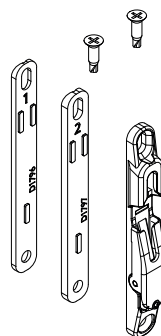

06390

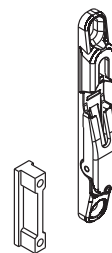

Direct fixing (A1)

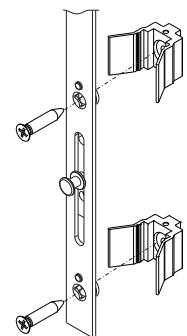

Item code	Description	Rod for matching	Type	Rod fixing to sash	Base Raw	Anodised Elox	Painted	Trend/Gold Brass	Pieces per pack
06344	Champion Plus Micro-ventilation FIXING KIT with 2 locking points	06334 - 06335 - 06337 - 06338	1	Direct (A1)	X				8
06345	Champion Plus Micro-ventilation FIXING KIT with 3 locking points	06336 - 06339 - 06340	1	Direct (A1)	X				8
06346	Champion Plus Micro-ventilation FIXING KIT with 2 locking points	06334 - 06335 - 06337 - 06338	2	Direct (A1)	X				8
06347	Champion Plus Micro-ventilation FIXING KIT with 3 locking points	06336 - 06339 - 06340	2	Direct (A1)	X				8
06348	Champion Plus Micro-ventilation FIXING KIT with 2 locking points	06334 - 06335 - 06337 - 06338	1	Direct (A1)	X				8
06349	Champion Plus Micro-ventilation FIXING KIT with 3 locking points	06336 - 06339 - 06340	1	Direct (A1)	X				8
06354	Champion Plus Micro-ventilation FIXING KIT with 2 locking points	06334 - 06335 - 06337 - 06338	1	Direct (A1)	X				8
06355	Champion Plus Micro-ventilation FIXING KIT with 3 locking points	06336 - 06339 - 06340	1	Direct (A1)	X				8
06356	Champion Plus Micro-ventilation FIXING KIT with 2 locking points	06334 - 06335 - 06337 - 06338	2	Direct (A1)	X				8
06357	Champion Plus Micro-ventilation FIXING KIT with 3 locking points	06336 - 06339 - 06340	2	Direct (A1)	X				8
06358	Champion Plus Micro-ventilation FIXING KIT with 2 locking points	06334 - 06335 - 06337 - 06338	2	Direct (A1)	X				8
06359	Champion Plus Micro-ventilation FIXING KIT with 3 locking points	06336 - 06339 - 06340	2	Direct (A1)	X				8
06364	Champion Plus Micro-ventilation FIXING KIT with 2 locking points	06334 - 06335 - 06337 - 06338	1	Direct (A1)	X				8
06365	Champion Plus Micro-ventilation FIXING KIT with 3 locking points	06336 - 06339 - 06340	1	Direct (A1)	X				8
06366	Champion Plus Micro-ventilation FIXING KIT with 2 locking points	06334 - 06335 - 06337 - 06338	1	Direct (A1)	X				8
06367	Champion Plus Micro-ventilation FIXING KIT with 3 locking points	06336 - 06339 - 06340	1	Direct (A1)	X				8
06368	Champion Plus Micro-ventilation FIXING KIT with 2 locking points	06334 - 06335 - 06337 - 06338	3	Direct (A1)	X				8
06369	Champion Plus Micro-ventilation FIXING KIT with 3 locking points	06336 - 06339 - 06340	3	Direct (A1)	X				8
06370	CHAMPION PLUS UNIVERSAL MICRO-VENTILATION FIXING KIT	06334-06335-06336-06337-06338-06339-06340	-	-	X				8
06374	Universal Champion Plus Micro-ventilation FIXING KIT with 2 locking points	06334-06335-06337-06338	4	Direct (A1)	X				8
06375	Universal Champion Plus Micro-ventilation FIXING KIT with 3 locking points	06336-06339-06340	4	Direct (A1)	X				8

CHAMPION PLUS MULTILOCK

Item code	Description	Rod for matching	Type	Rod fixing to sash	Base Raw	Anodised Elox	Painted	Trend/Gold Brass	Pieces per pack
06384	Champion Plus Micro-ventilation FIXING KIT with 2 locking points	06334-06335-06337-06338	1	Direct (A1)	X				8
06385	Champion Plus Micro-ventilation FIXING KIT with 3 locking points	06336-06339-06340	1	Direct (A1)	X				8
06386	Champion Plus Micro-ventilation FIXING KIT with 2 locking points	06334-06335-06337-06338	5	Direct (A1)	X				8
06387	Champion Plus Micro-ventilation FIXING KIT with 3 locking points	06336-06339-06340	5	Direct (A1)	X				8
06388	Champion Plus Micro-ventilation FIXING KIT with 2 locking points	06334-06335-06337-06338	6	Direct (A1)	X				8
06389	Champion Plus Micro-ventilation FIXING KIT with 3 locking points	06336-06339-06340	6	Direct (A1)	X				8
06390	CHAMPION PLUS MICRO-VENTILATION FIXING KIT	06334-06335-06336-06337-06338-06339-06340	-	-	X				8
06394	Champion Plus Micro-ventilation FIXING KIT with 2 locking points	06334-06335-06337-06338	7	Direct (A1)	X				8
06395	Champion Plus Micro-ventilation FIXING KIT with 3 locking points	06336-06339-06340	7	Direct (A1)	X				8

CHAMPION PLUS CLOSING RODS

Functions

Complete system of multi-lock rods (1 to 3 points) for sliding windows or balcony-doors made of aluminium.

Online data sheet



Technical Features

Three versions are available:

- Backset 7.5 mm (1 to 3 locking points)
- Backset 15 mm (1 to 3 locking points)
- Backset 15 mm with lock (3 locking points)

All the rods are operated by traditional window handles or recess handles equipped with a 7 mm square pin.

These multi-locks have 2 operating positions:

- 1) 0° CLOSED SASH
- 2) 90° OPEN SASH

Depending on the series used, the rods have to be matched with specific coupling kits designed to adapt them to the various shapes of the profile.

The strength of the mushroom nib is greater than 150 kg.

The Champion Plus fastening rods with 2 and 3 locking points are compatible with the incorrect movement safety device art. 02770, which prevents the window handle from returning to the closed position with the sash open.

Materials

Zinc-plated steel lift-proof pin and rods
Box for rotor and nibs in zamak

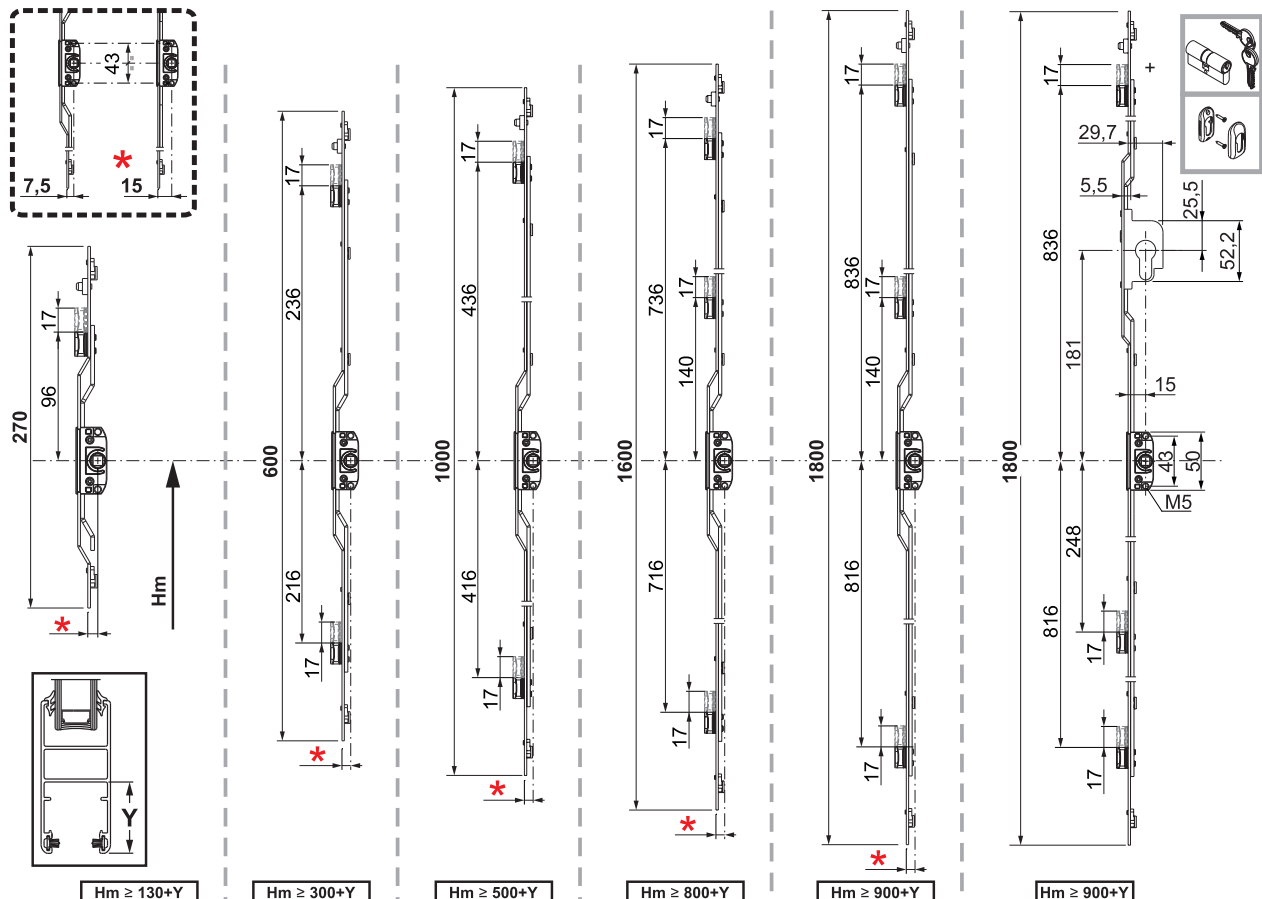

CHAMPION PLUS MULTILOCK

Item code	Description	Backset	Lock	Incorrect Movement Safety Device Compatibility	Length	Window handle height	Locking points	Base Raw	Anodised Elox	Painted	Trend/Gold Brass	Pieces per pack
0272001	CHAMPION PLUS ROD	7,5	NO	NO	270	> 130 + Y	1	X				4
0272101	CHAMPION PLUS ROD	7,5	NO	YES	600	> 300 + Y	2	X				4
0272201	CHAMPION PLUS ROD	7,5	NO	YES	1000	> 500 + Y	2	X				4
0630901	CHAMPION PLUS ROD	7,5	NO	Yes	1600	> 800 + Y	3	X				4
0272301	CHAMPION PLUS ROD	7,5	NO	YES	1800	> 900 + Y	3	X				4
0272401	CHAMPION PLUS ROD	15	NO	NO	270	> 130 + Y	1	X				4
0272501	CHAMPION PLUS ROD	15	NO	YES	600	> 300 + Y	2	X				4
0272601	CHAMPION PLUS ROD	15	NO	YES	1000	> 500 + Y	2	X				4
0631001	CHAMPION PLUS ROD	15	NO	YES	1600	> 800 + Y	3	X				4
0272701	CHAMPION PLUS ROD	15	NO	YES	1800	> 900 + Y	3	X				4
0272801	CHAMPION PLUS ROD WITH LOCK	15	YES	YES	1800	> 900 + Y	3	X				4



CHAMPION PLUS FIXING KIT

Functions

The fixing kit is necessary to correctly and durably apply a Champion rod in a specific aluminium sliding system and to obtain the micro-air circulation function.

Online data sheet



Technical Features

The Champion Plus fixing kit with micro-ventilation is available in 3 versions:

- for 1 point multi-lock
- for 2 point multi-lock
- for 3 point multi-lock

The Champion Plus fixing kit usually includes all those components necessary to apply the fastening rod in a specific aluminium sliding system.

These kits therefore generally include:

- Shims to adapt the rod to the sash profile
- Frame counterplates
- Frame counterplate adjustment shims
- Lift-proof component
- Fixing screws
- Window handle spacer tubes

The rod adjustment shims snap into place, facilitating hardware installation operations.

Depending on the sliding system used, these adapters provide different fixing systems:

- direct to the profile, in which the screw grips directly in the sash profile
- with expansion (patented by Giesse) in which the adapter expands and anchors to the sash profile without the need for drilling

Materials

Shims for adapting the rod to the profile, counterplate shims and window handle spacers of grey polyamide

Screws for fixing rod to profile in stainless steel
 Frame counterplate made of zinc plated steel
 Anti-lift component and retractor (where applicable) made of die-cast zamak

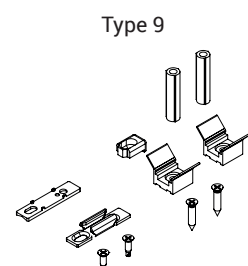
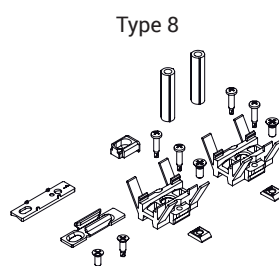
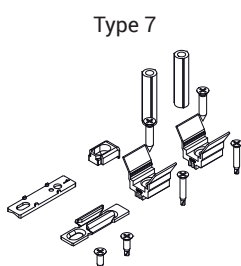
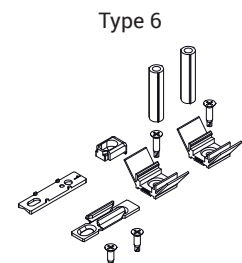
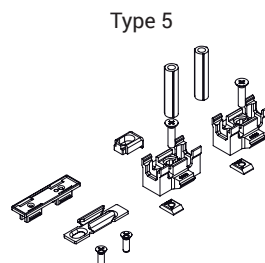
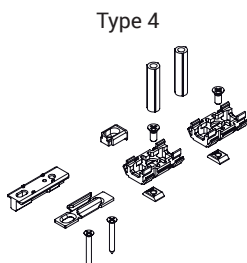
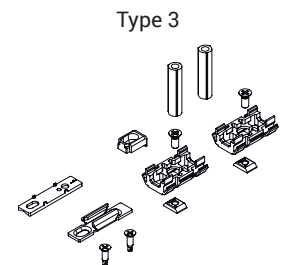
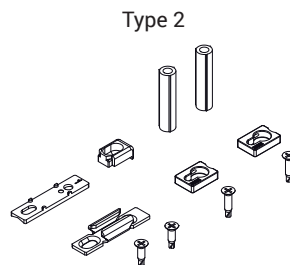
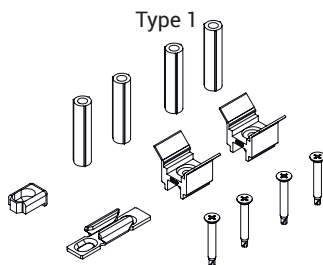

Type 10

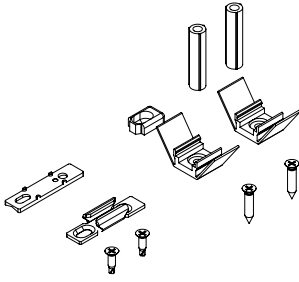

Type 11

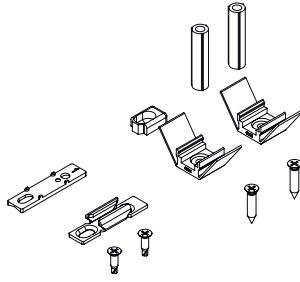

Type 12

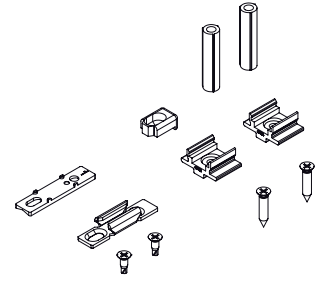

Type 13

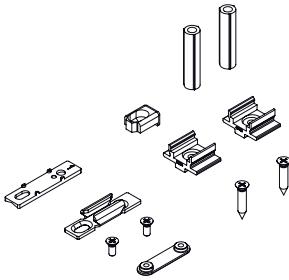

Type 14

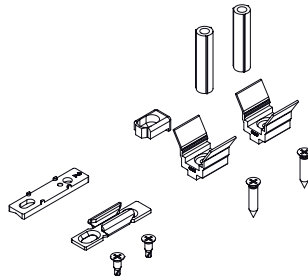

Type 15

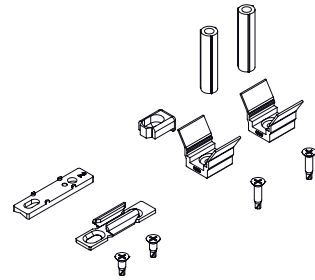

Type 16

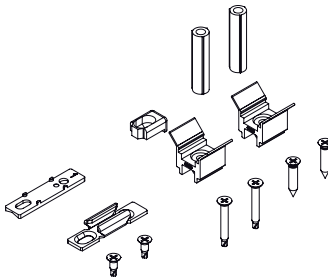

Type 17

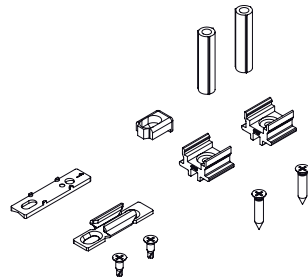

Type 18

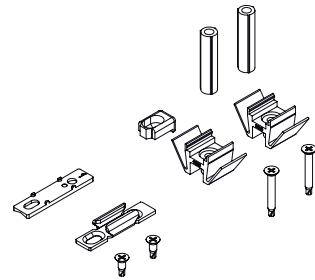

Type 19

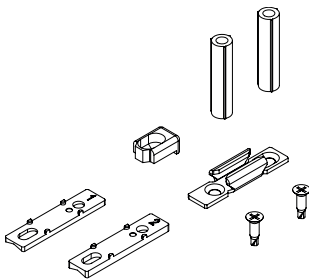

Type 20

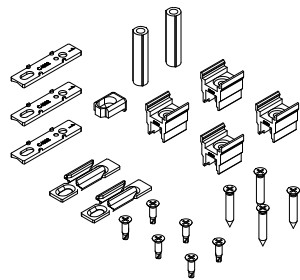

Type 21

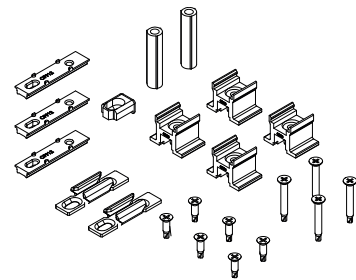

Direct fixing (A1)

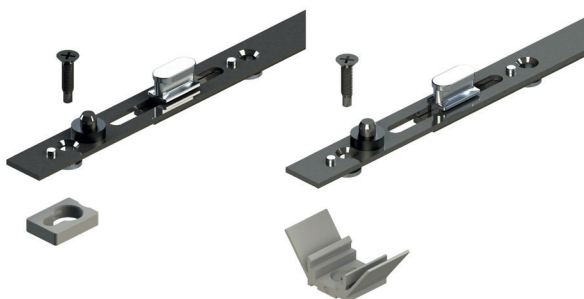

Expansion fixing (A2)

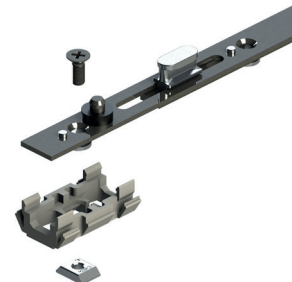

Item code	Description	Rod for matching	Type	Rod fixing to sash	Base Raw	Anodised Elox	Painted	Trend/Gold Brass	Pieces per pack
06040	FIXING KIT for Champion Plus with 2 locking points	02721 - 02722 - 02725 - 02726	20	Direct (A1)	X				8
06044	FIXING KIT for Champion Plus with 2 locking points	02721 - 02722 - 02725 - 02726	15	Direct (A1)	X				8
06045	FIXING KIT for Champion Plus with 3 locking points	02723 - 02727 - 02728 - 06309 - 06710	15	Direct (A1)	X				8
06046	FIXING KIT for Champion Plus with 2 locking points	02721 - 02722 - 02725 - 02726	21	Direct (A1)	X				8
06047	FIXING KIT for Champion Plus with 3 locking points	02723 - 02727 - 02728 - 06309 - 06710	21	Direct (A1)	X				8
06048	FIXING KIT for Champion Plus with 3 locking points	02723 - 02727 - 02728 - 06309 - 06710	20	Direct (A1)	X				8
06112	FIXING KIT for Champion Plus with 2 locking points	02721 - 02722 - 02725 - 02726	20	Direct (A1)	X				8
06113	FIXING KIT for Champion Plus with 3 locking points	02723 - 02727 - 02728 - 06309 - 06710	20	Direct (A1)	X				8
06231	FIXING KIT for Champion Plus with 1 locking point	02720 - 02724	1	Direct (A1)	X				8
06232	FIXING KIT for Champion Plus with 2 locking points	02721 - 02722 - 02725 - 02726	1	Direct (A1)	X				8
06233	FIXING KIT for Champion Plus with 3 locking points	02723 - 02727 - 02728 - 06309 - 06710	1	Direct (A1)	X				8
06301	FIXING KIT for Champion Plus with 1 locking point	02720 - 02724	2	Direct (A1)	X				8
06302	FIXING KIT for Champion Plus with 2 locking points	02721 - 02722 - 02725 - 02726	2	Direct (A1)	X				8
06303	FIXING KIT for Champion Plus with 3 locking points	02723 - 02727 - 02728 - 06309 - 06710	2	Direct (A1)	X				8
06311	FIXING KIT for Champion Plus with 1 locking point	02720 - 02724	3	Expansion fixing (A2)	X				8
06312	FIXING KIT for Champion Plus with 2 locking points	02721 - 02722 - 02725 - 02726	3	Expansion fixing (A2)	X				8
06313	FIXING KIT for Champion Plus with 3 locking points	02723 - 02727 - 02728 - 06309 - 06710	3	Expansion fixing (A2)	X				8
06321	FIXING KIT for Champion Plus with 1 locking point	02720 - 02724	4	Expansion fixing (A2)	X				8
06322	FIXING KIT for Champion Plus with 2 locking points	02721 - 02722 - 02725 - 02726	4	Expansion fixing (A2)	X				8
06323	FIXING KIT for Champion Plus with 3 locking points	02723 - 02727 - 02728 - 06309 - 06710	4	Expansion fixing (A2)	X				8
06325	FIXING KIT for Champion Plus with 2 locking points	02721 - 02722 - 02725 - 02726	9	Direct (A1)	X				8
06326	FIXING KIT for Champion Plus with 3 locking points	02723 - 02727 - 02728 - 06309 - 06710	9	Direct (A1)	X				8
06332	FIXING KIT for Champion Plus with 2 locking points	02721 - 02722 - 02725 - 02726	5	Expansion fixing (A2)	X				8
06333	FIXING KIT for Champion Plus with 3 locking points	02723 - 02727 - 02728 - 06309 - 06710	5	Expansion fixing (A2)	X				8
06342	FIXING KIT for Champion Plus with 2 locking points	02721 - 02722 - 02725 - 02726	6	Direct (A1)	X				8
06343	FIXING KIT for Champion Plus with 3 locking points	02723 - 02727 - 02728 - 06309 - 06710	6	Direct (A1)	X				8
06351	FIXING KIT for Champion Plus with 1 locking point	02720 - 02724	7	Direct (A1)	X				8
06352	FIXING KIT for Champion Plus with 2 locking points	02721 - 02722 - 02725 - 02726	7	Direct (A1)	X				8
06353	FIXING KIT for Champion Plus with 3 locking points	02723 - 02727 - 02728 - 06309 - 06710	7	Direct (A1)	X				8
06362	FIXING KIT for Champion Plus with 2 locking points	02721 - 02722 - 02725 - 02726	8	Expansion fixing (A2)	X				8
06371	FIXING KIT for Champion Plus with 1 locking point	02720 - 02724	2	Direct (A1)	X				8
06372	FIXING KIT for Champion Plus with 2 locking points	02721 - 02722 - 02725 - 02726	2	Direct (A1)	X				8
06373	FIXING KIT for Champion Plus with 3 locking points	02723 - 02727 - 02728 - 06309 - 06710	2	Direct (A1)	X				8

CHAMPION PLUS MULTILOCK

Item code	Description	Rod for matching	Type	Rod fixing to sash	Base Raw	Anodised Elox	Painted	Trend/Gold Brass	Pieces per pack
06381	FIXING KIT for Champion Plus with 1 locking point	02720 - 02724	10	Direct (A1)	X				8
06382	FIXING KIT for Champion Plus with 2 locking points	02721 - 02722 - 02725 - 02726	10	Direct (A1)	X				8
06383	FIXING KIT for Champion Plus with 3 locking points	02723 - 02727 - 02728 - 06309 - 06710	10	Direct (A1)	X				8
06391	FIXING KIT for Champion Plus with 1 locking point	02720 - 02724	11	Direct (A1)	X				8
06392	FIXING KIT for Champion Plus with 2 locking points	02721 - 02722 - 02725 - 02726	11	Direct (A1)	X				8
06393	FIXING KIT for Champion Plus with 3 locking points	02723 - 02727 - 02728 - 06309 - 06710	11	Direct (A1)	X				8
06421	FIXING KIT for Champion Plus with 1 locking point	02720 - 02724	12	Direct (A1)	X				8
06422	FIXING KIT for Champion Plus with 2 locking points	02721 - 02722 - 02725 - 02726	12	Direct (A1)	X				8
06423	FIXING KIT for Champion Plus with 3 locking points	02723 - 02727 - 02728 - 06309 - 06710	12	Direct (A1)	X				8
06431	FIXING KIT for Champion Plus with 1 locking point	02720 - 02724	13	Direct (A1)	X				8
06441	FIXING KIT for Champion Plus with 1 locking point	02720 - 02724	14	Direct (A1)	X				8
06443	FIXING KIT for Champion Plus with 3 locking points	02723 - 02727 - 02728 - 06309 - 06710	14	Direct (A1)	X				8
06451	FIXING KIT for Champion Plus with 1 locking point	02720 - 02724	15	Direct (A1)	X				8
06452	FIXING KIT for Champion Plus with 2 locking points	02721 - 02722 - 02725 - 02726	15	Direct (A1)	X				8
06453	FIXING KIT for Champion Plus with 3 locking points	02723 - 02727 - 02728 - 06309 - 06710	15	Direct (A1)	X				8
06461	FIXING KIT for Champion Plus with 1 locking point	02720 - 02724	16	Direct (A1)	X				8
06462	FIXING KIT for Champion Plus with 2 locking points	02721 - 02722 - 02725 - 02726	16	Direct (A1)	X				8
06463	FIXING KIT for Champion Plus with 3 locking points	02723 - 02727 - 02728 - 06309 - 06710	16	Direct (A1)	X				8
06471	FIXING KIT for Champion Plus with 1 locking point	02720 - 02724	17	Direct (A1)	X				8
06472	FIXING KIT for Champion Plus with 2 locking points	02721 - 02722 - 02725 - 02726	17	Direct (A1)	X				8
06473	FIXING KIT for Champion Plus with 3 locking points	02723 - 02727 - 02728 - 06309 - 06710	17	Direct (A1)	X				8
06481	FIXING KIT for Champion Plus with 1 locking point	02720 - 02724	18	Direct (A1)	X				8
06482	FIXING KIT for Champion Plus with 2 locking points	02721 - 02722 - 02725 - 02726	18	Direct (A1)	X				8
06483	FIXING KIT for Champion Plus with 3 locking points	02723 - 02727 - 02728 - 06309 - 06710	18	Direct (A1)	X				8
06491	FIXING KIT for Champion Plus with 1 locking point	02720 - 02724	19	Sash side adapters and fixing screws not included in the kit	X				8
06492	FIXING KIT for Champion Plus with 2 locking points	02721 - 02722 - 02725 - 02726	19	Sash side adapters and fixing screws not included in the kit	X				8
06493	FIXING KIT for Champion Plus with 3 locking points	02723 - 02727 - 02728 - 06309 - 06710	19	Sash side adapters and fixing screws not included in the kit	X				8
06792	FIXING KIT for Champion Plus with 2 locking points	02721 - 02722 - 02725 - 02726	20	Direct (A1)	X				8
06793	FIXING KIT for Champion Plus with 3 locking points	02723 - 02727 - 02728 - 06309 - 06710	20	Direct (A1)	X				8



CHAMPION PLUS CLOSING RODS 90

Functions

Complete system of multi-lock rods (2 to 3 points) for sliding windows or balcony-doors made of aluminium.

Online data sheet



Technical Features

Available in two versions:

- Backset 15 mm (2 to 3 locking points)
- Backset 15 mm with lock (3 locking points)

All the rods are operated by traditional window handles or recess handles equipped with a 7 mm square pin.

These multi-locks have 2 operating positions:

- 1) 0° CLOSED SASH
- 2) 90° OPEN SASH

Materials

Zinc-plated steel lift-proof pin and rods
Box for rotor and nibs in zamak

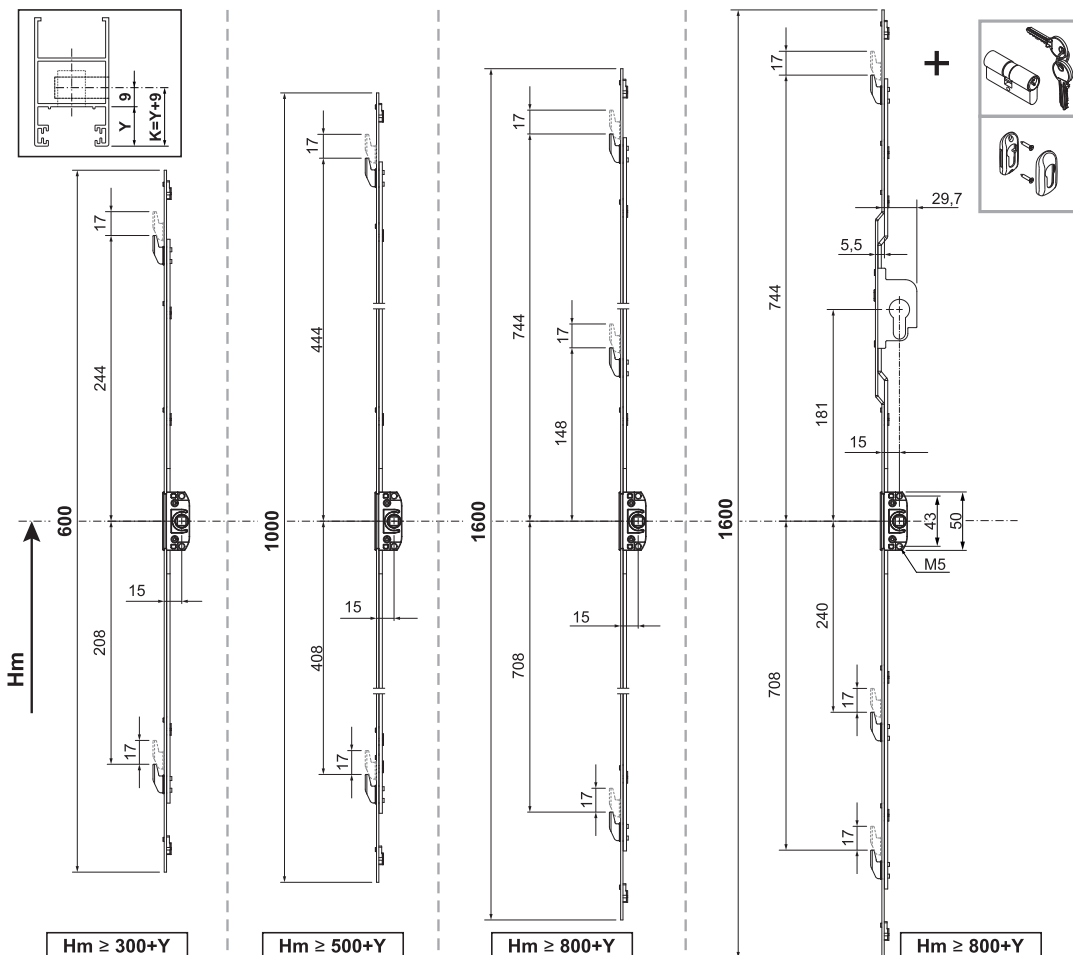

CHAMPION PLUS MULTILOCK

06324

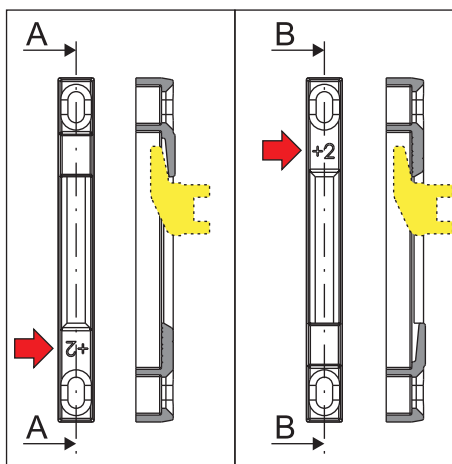
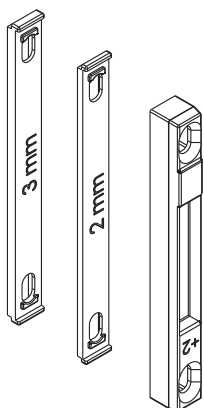

06360

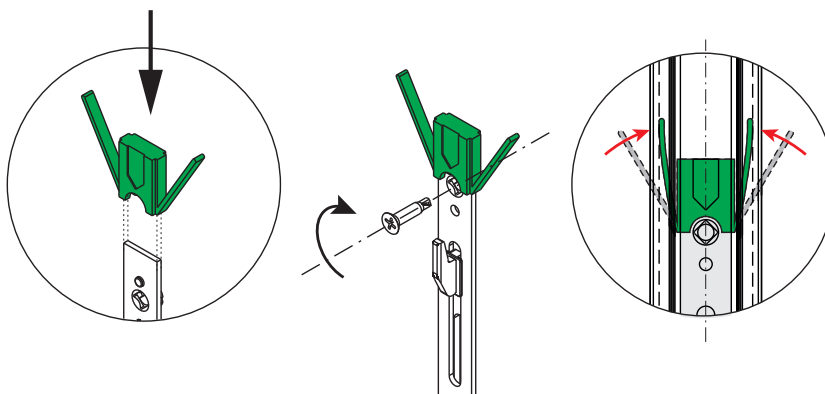
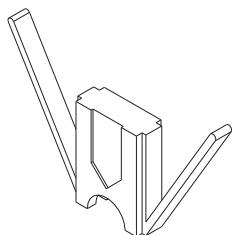

Item code	Description	Backset	Lock	Incorrect Movement Safety Device Compatibility	Length	Window handle height	Locking points	Base Raw	Anodised Elox	Painted	Trend/Gold Brass	Pieces per pack
06327	CHAMPION PLUS ROD 90	15	NO	NO	600	$\geq 300 + Y$	2	X				4
06328	CHAMPION PLUS ROD 90	15	NO	NO	1000	$\geq 500 + Y$	2	X				4
06329	CHAMPION PLUS ROD 90	15	NO	NO	1600	$\geq 800 + Y$	3	X				4
06330	CHAMPION PLUS ROD 90	15	YES	NO	1600	$\geq 800 + Y$	3	X				4

Item code	Description	Note	Base Raw	Anodised Elox	Painted	Trend/Gold Brass	Pieces per pack
06324	CHAMPION PLUS 90 COUNTER-PLATE KIT		X				20
06360	CHAMPION PLUS 90 CENTRING TEMPLATE		X				5



INCORRECT MOVEMENT SAFETY DEVICE

Functions

Device that prevents, with the sash open, bringing the hardware into the closed position.

Online data sheet



Technical Features

Easily fitted on all Champion Plus Multilocks with 2 or 3 locking points.
 Acts as protection for the hardware preventing accidental impact between the ribs and counterplates.
 Prevents the user of the window from inadvertently putting the window handle into the closed position when the sash is open.
 Only when the sash is closed and then moved next to the frame will the device unlock and allow turning the pull handle and subsequently closing the sash.
 It can be used in combination with all Champion Plus rods without micro-ventilation.
 Compatible with Champion Plus rods with micro-ventilation only with cremone locked at 90°.

Materials

Incorrect movement safety device body and button made of die-cast zamak
 Return spring made of harmonic steel
 Stainless steel fixing screw
 Frame striker of polyamide

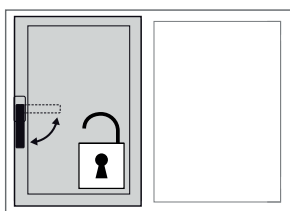
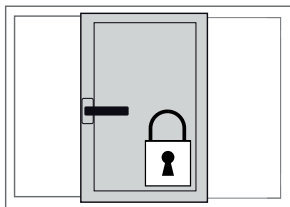

A = contained in the Champion Plus fixing kit

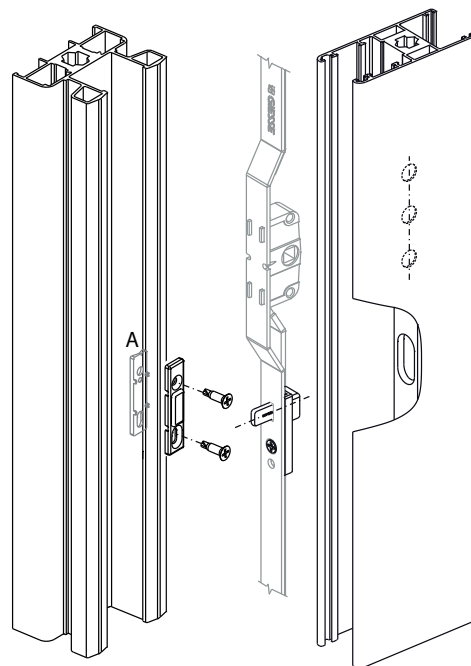

Item code	Description	Can be combined with	Base Raw	Anodised Elox	Painted	Trend/Gold Brass	Pieces per pack
02770	INCORRECT MOVEMENT SAFETY DEVICE	0272101 - 0272201 - 0272301 - 0272501 - 0272601 - 0272701 - 0272801 - 0630901 - 0631001	X				8

PRIMA CHAMPION PLUS WINDOW HANDLE



Functions

Window handle that is applied on the main sash of a sliding casement.

Online data sheet



Technical Features

Two versions are available, single and double (balcony doors), the Prima window handle provides easy operation of the Champion Plus multi-lock. Equipped with a 7 mm square pin and a positioner for stopping the handle at 0° and 180°.

Materials

Handle, plate-cover and rotor in die-cast zamak
Square pin and screws in stainless steel
Polyamide plate

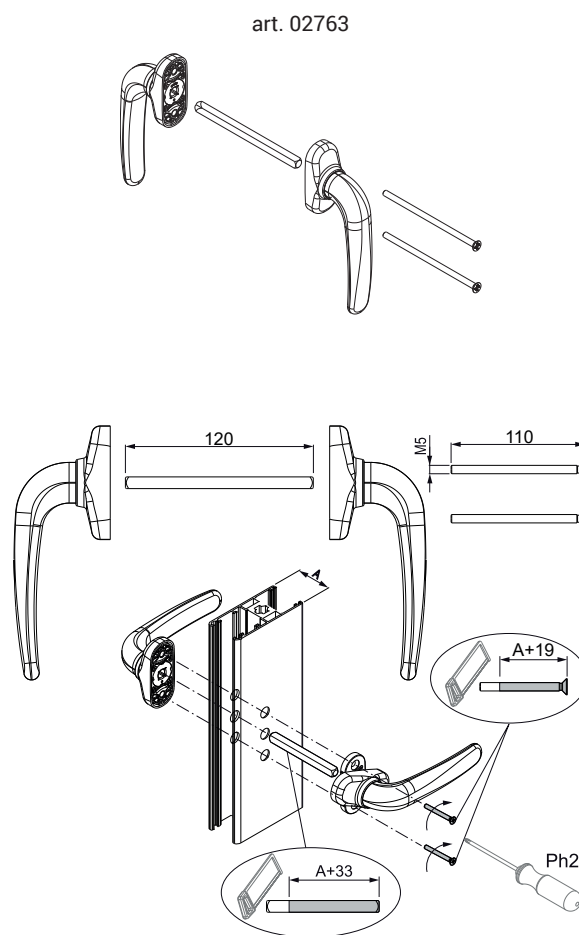
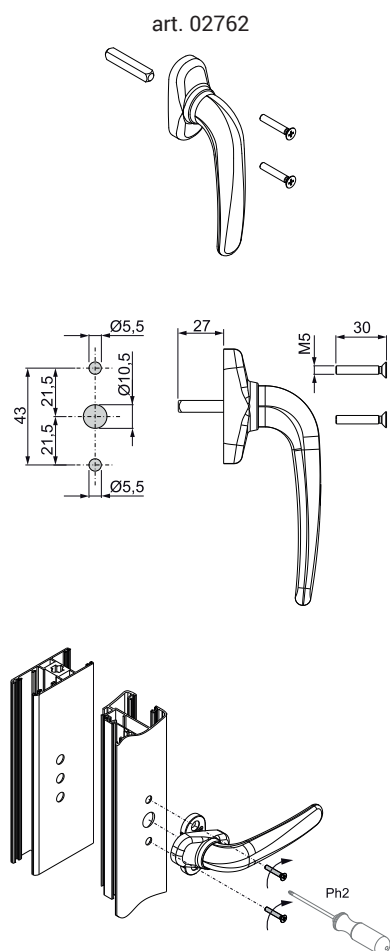

Item code	Description	PROFILE CROSS - SECTION	Applicable	Base Raw	Anodised Elox	Painted	Trend/Gold Brass	Pieces per pack
02762	PRIMA WINDOW HANDLE	C001-C002-C003-C004-C005-C006-C007-C009-C010-C011-C012-C013-C014-C015-C016-C017-P001-P002-P003-P004-P005-P006-P007-P008-P009-P010	internal	X		X	X	5
02763	DOUBLE PRIMA WINDOW HANDLE	-	internal/external	X		X	X	5



RECESSED WINDOW HANDLE

Functions

Window handle that is applied on the secondary sash of a sliding casement.

Online data sheet



Technical Features

Not being top-hung, it allows overlapping the sashes.
 Equipped with a 7 mm square pin and a positioner for stopping the handle at 0° and 180°.
 The product has its own system for fixing to the stand-alone profile compared to the M5x25 screws fastening the window handle to the internal mechanism.
 Depending on the shape of the sash profile, the manufacturer will decide on how to prepare the recessed window handle with parts A or B so that the product is anchored in an effective and long-lasting manner.

Materials

External body, pull handle and fixing components made of die-cast zamak
 Square pin and fixing screws in zinc plated steel
 Hostaform snap disk
 Locking washer made of harmonic steel

art. 02760

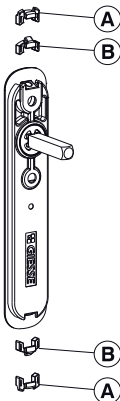
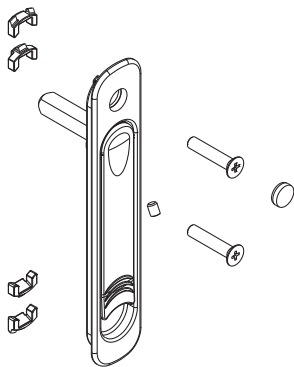

art. 02761

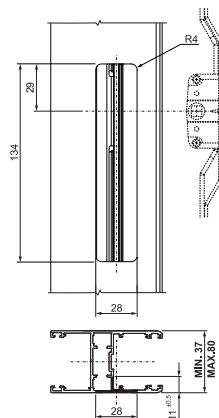
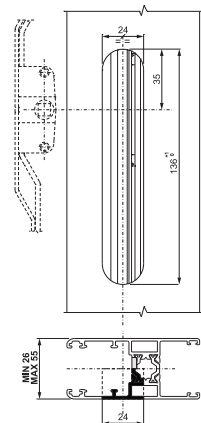
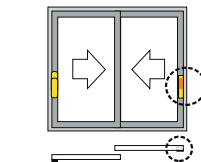
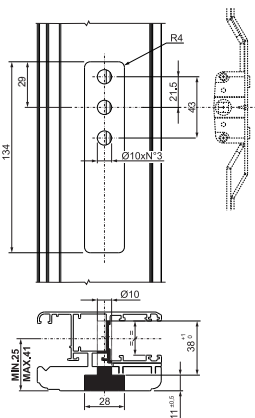
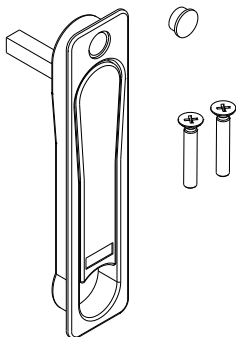

Item code	Description	Applicable	Notes	Base Raw	Anodised Elox	Painted	Trend/Gold Brass	Pieces per pack
02760	RECESSED WINDOW HANDLE	internal		X		X	X	8
02761	RECESSED WINDOW HANDLE	internal	Alu/wood or Alu profiles > 37 mm	X		X	X	8



EXTERNAL RECESS PULL HANDLE

Functions

The external recess pull handle has the function of pulling a sliding sash and works in conjunction with a window handle on the inside of the casement.

Online data sheet



Technical Features

The external recess pull handle has the function of pulling a sliding sash and works in conjunction with a window handle on the inside of the casement. This article is fitted externally and performs the function of pulling a sliding sash.

This product works in combination with the recess window handle or in combination with the Prima window handle.

The metric screws supplied with the window handle for the inside are screwed into the external recess handle, joining the 2 products with the profile

Materials

External body and lever made of die-cast zamak
Zinc plated steel screws

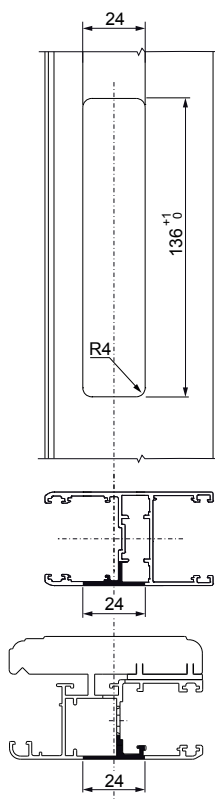

A: out
B: in

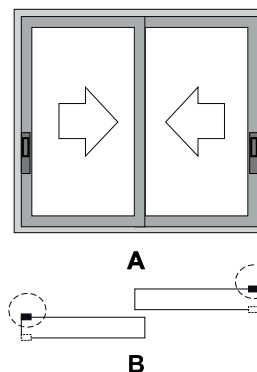

Item code	Description	Applicable	Can be combined with	Base Raw	Anodised Elox	Painted	Trend/Gold Brass	Pieces per pack
02764	EXTERNAL RECESS PULL HANDLE	external	02760-02761-02762	X		X	X	8



BLIND INTERNAL RECESS PULL HANDLE

Functions

Blind recess handle to be applied on the opposite sash which has the sole function of drawing.

Online data sheet



Materials

Die-cast zamak coupling teeth and body
Stainless steel locking grub screw

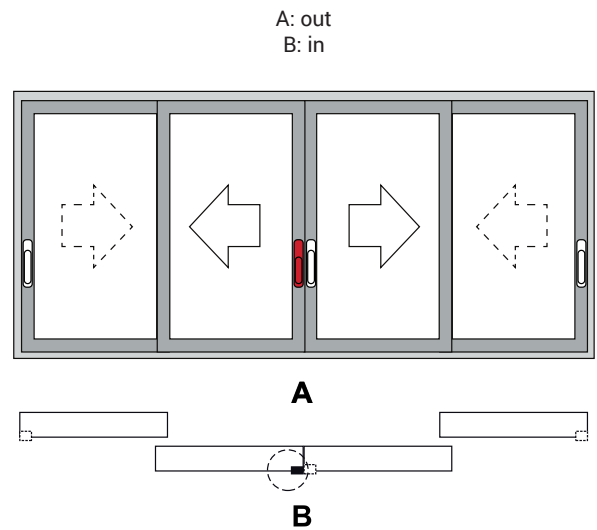
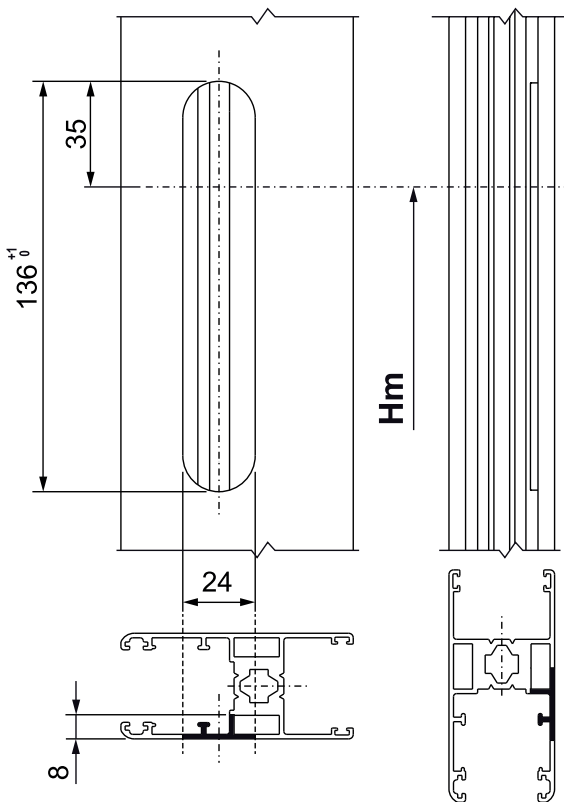

Item code	Description	Applicable	Notes	Base Raw	Anodised Elox	Painted	Trend/Gold Brass	Pieces per pack
02765	BLIND INTERNAL RECESS PULL HANDLE	internal	Opposing sashes	X		X	X	8

2-SASH WINDOW ASSEMBLY KIT

Functions

Set of necessary accessories to complete the assembly of a window or door with two sliding leaves made of aluminium, grouped together in a single package.

Online data sheet

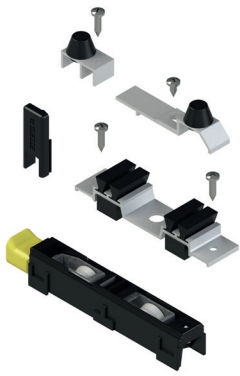

03106

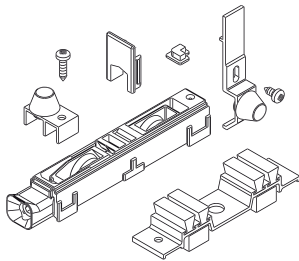

03108

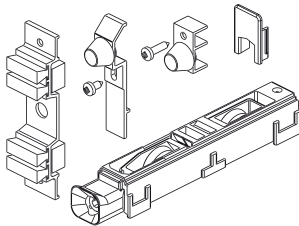

03114

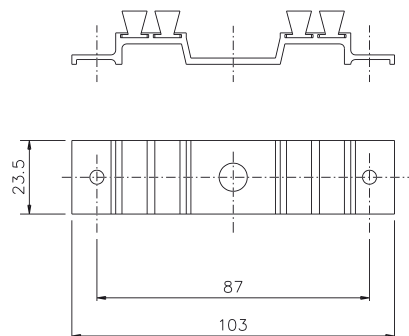
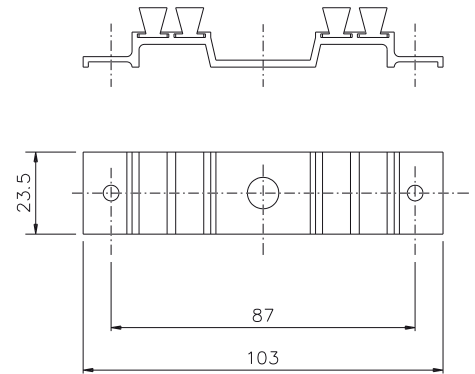
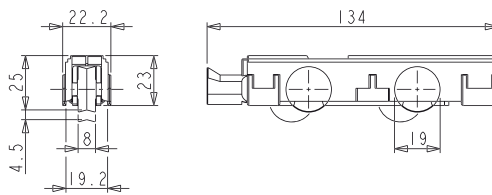
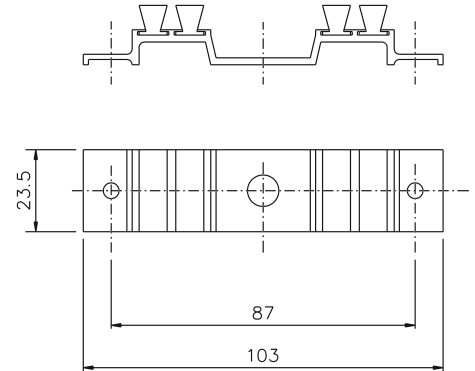
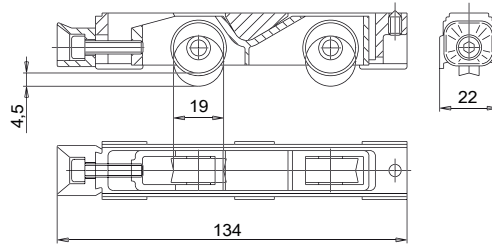

Item code	Description	Note	Base Raw	Anodised Elox	Painted	Trend/Gold Brass	Pieces per pack
03106	2-SASH WINDOW ASSEMBLY KIT		X				5
03108	2-SASH WINDOW ASSEMBLY KIT		X				5
03114	2-SASH WINDOW ASSEMBLY KIT		X				10

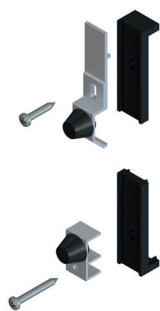

BURGLAR-PROOF AND DAMPER PLUGS

Functions

Burglar-proof damper plugs, specifically designed for aluminium sliding doors and windows.

Online data sheet



Technical features

The longer lug fits to the top part.

The protrusion must be located close to the top cross beam (about 2–3 mm away from it) so as to act as a burglar-proof device (to prevent the sash being removed).

Materials

Shims in black polyamide

Damper body in anodised extruded aluminium

Rubber damper plugs

Zinc plated steel screws

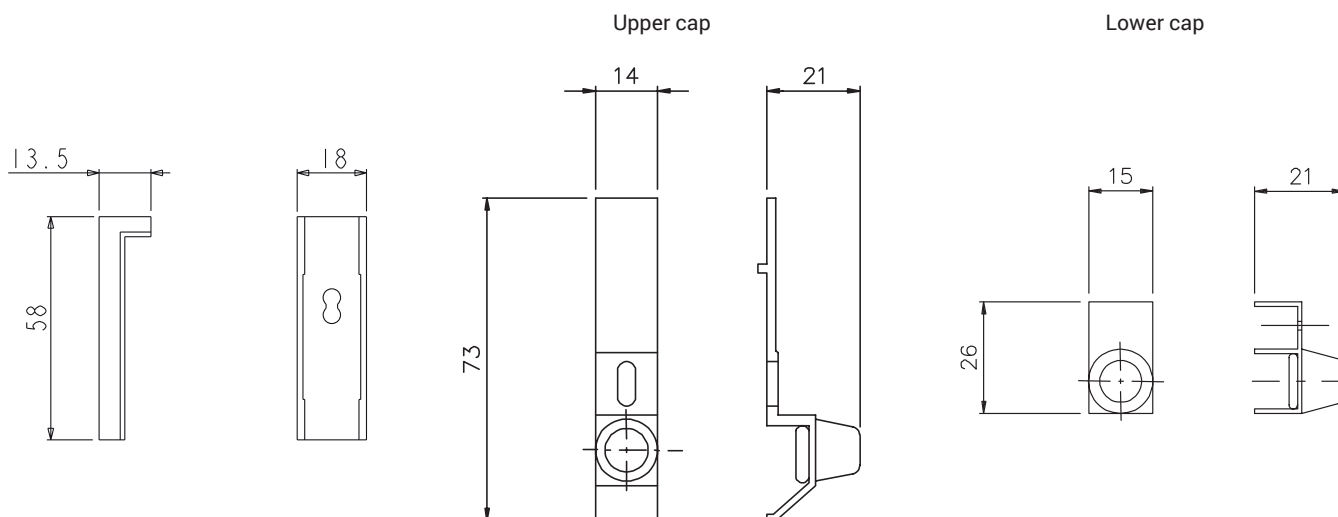

Item code	Description	Note	Base Raw	Anodised Elox	Painted	Trend/Gold Brass	Pieces per pack
02290	BURGLAR-PROOF AND DAMPER PLUGS		X				100

BURGLAR-PROOF AND DAMPER PLUGS

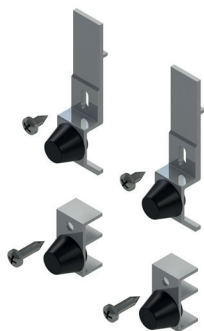

Functions

Burglar-proof damper plugs, specifically designed for aluminium sliding doors and windows.

Online data sheet



Technical features

The top aluminium part must be placed close to the upper cross beam to prevent the sash from being able to be removed (burglar-proof)

Materials

Stainless steel screws
 Damper body in anodised extruded aluminium
 Rubber damper plugs.

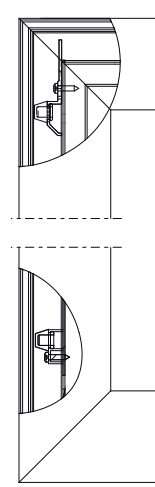
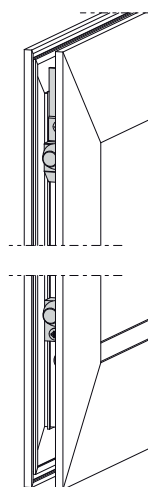
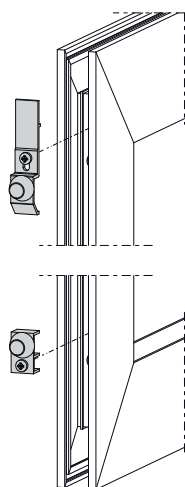
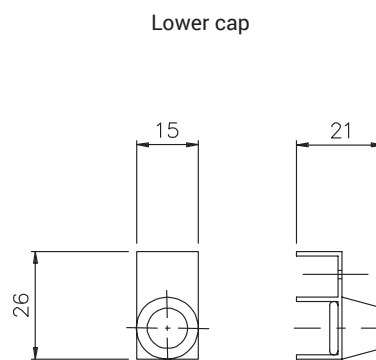
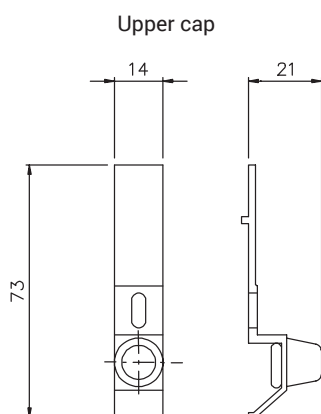

Item code	Description	Note	Base Raw	Anodised Elox	Painted	Trend/Gold Brass	Pieces per pack
03199X	BURGLAR-PROOF AND DAMPER PLUGS		X				200



BURGLAR-PROOF AND DAMPER PLUGS

Functions

Plug with damping and burglar-proof functions.

Online data sheet



Technical features

The plug is inserted on both the upper and lower parts of the sash upright in the channel and fixed by a contrast grub screw.

Materials

Black polyamide cap
Stainless steel M5x10 grub screw

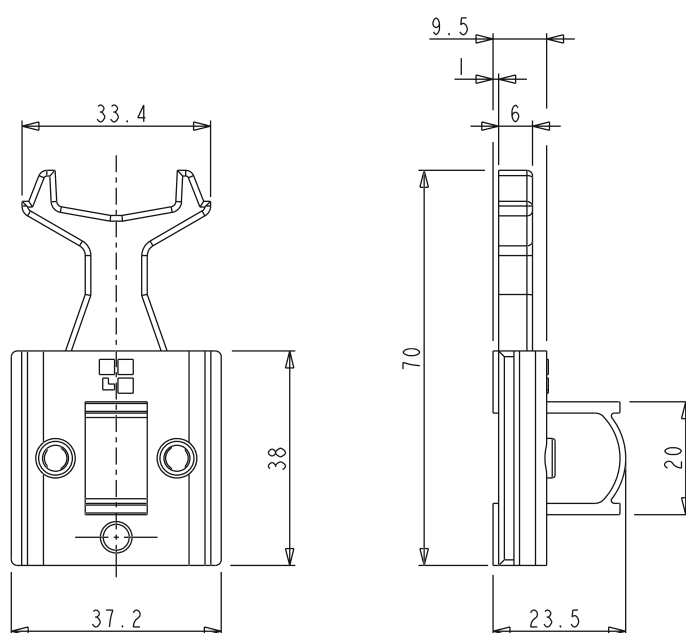

Item code	Description	Note	Base Raw	Anodised Elox	Painted	Trend/Gold Brass	Pieces per pack
03200	BURGLAR-PROOF AND DAMPER PLUGS		X				100

SASH STOP DEVICE

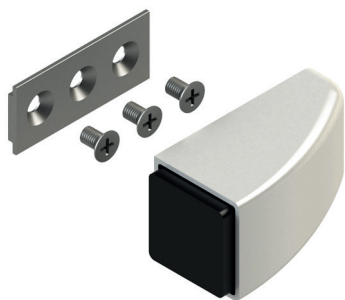

Functions

Device to apply on sliding profiles to stop the sash before it hurts the handle.

[Online data sheet](#)



Technical Features

The sash stop device should be positioned on the lower transom. In case of special dimensions, it should be positioned even on the top transom to avoid the collision between the handle and the other sash.

The device is removable and allows the overlap of the sash.

Polyamide body available in white, grey and black.

Materials

Polyamide reinforced with fiber glass body

Aluminium plate

Foam rubber pad

Zinc plated steel screws

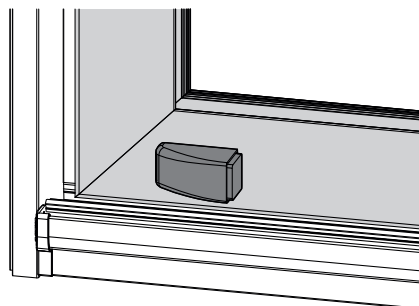
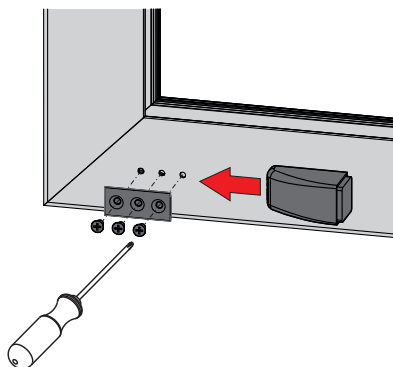
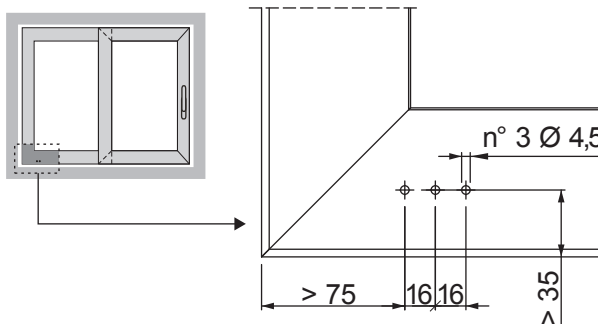
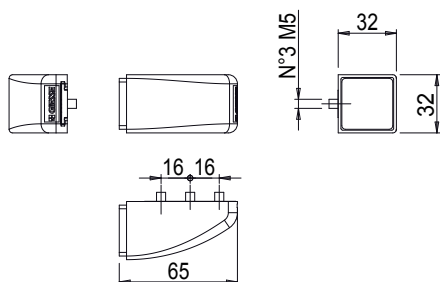

Item code	Description	Note	Base Raw	Anodised Elox	Painted	Trend/Gold Brass	Pieces per pack
03978	SASH STOP DEVICE	Reversible	X				10

DUST-PROOF PLUG



Functions

Component designed to prevent dust and water passing into the interior of the sliding door/window.

Online data sheet



Technical features

The dust cap fits to the upper and lower cross beams of the fixed frame using self-tapping screws.

The sponge fits snugly against the sash to prevent dust and water entering.

Materials

Black anodised extruded aluminium body

Zinc plated steel screws

Brushes and sponge in expanded EPDM

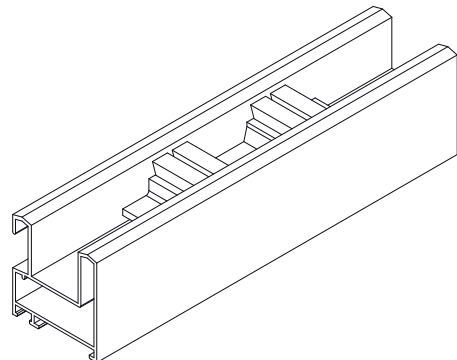
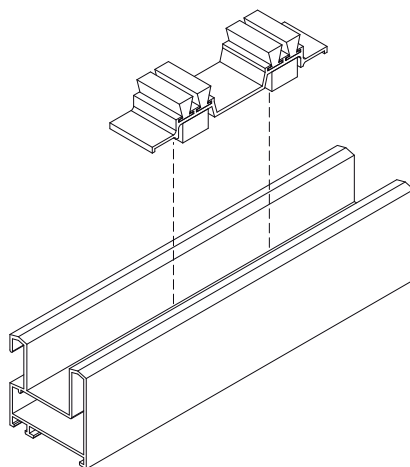
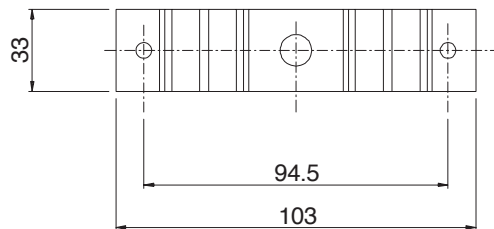
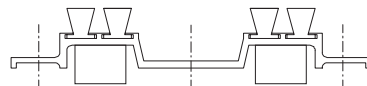

Item code	Description	Note	Base Raw	Anodised Elox	Painted	Trend/Gold Brass	Pieces per pack
01220	DUST-PROOF PLUG		X				50

MACHINING COVER

Functions

Package includes 4 central upright caps, 8 sash guide plugs and 2 dust-proof covers for a window or sliding door made of aluminium.

Online data sheet



Technical features

The machining caps improve the appearance of the sash by covering the machining on the central upright.

The sash guiding plugs stabilize the sash and prevent the pulley from being able to come off the rail.

The dust cap fits to the upper and lower cross beams of the fixed frame using self-tapping screws.

The sponge fits snugly against the sash to prevent dust and water entering.

Materials

Black anodised extruded aluminium body

Screws and grub screws in zinc plated steel

Brushes and sponge in expanded EPDM

Cover for machining and sash guide in black polyamide

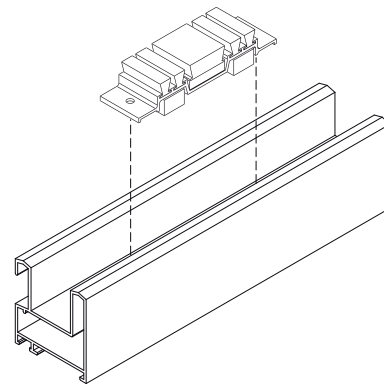
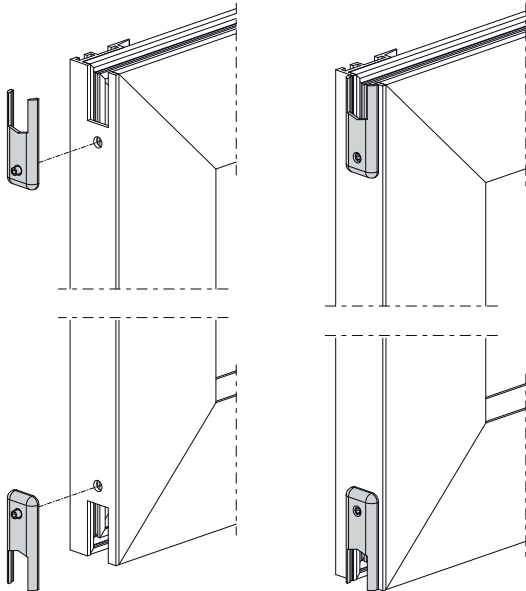
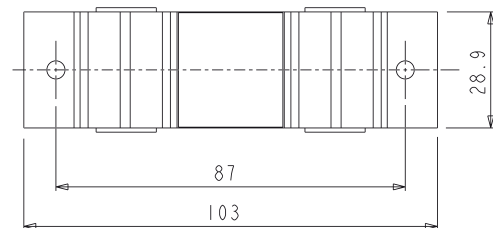
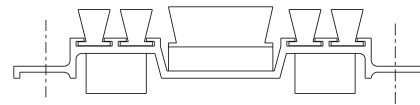
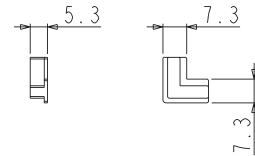
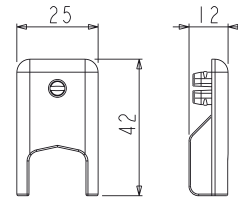

Item code	Description	Note	Base Raw	Anodised Elox	Painted	Trend/Gold Brass	Pieces per pack
01221	MACHINING COVER		X				100

DUST-PROOF PLUG

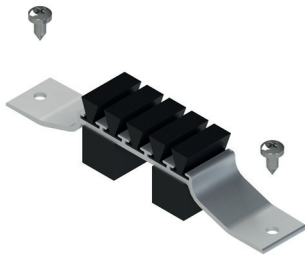

Functions

Component designed to prevent dust and water passing into the interior of the sliding door/window.

Online data sheet



Technical features

The dust cap fits to the upper and lower cross beams of the fixed frame using self-tapping screws.

The sponge fits snugly against the sash to prevent dust and water entering.

Materials

Black anodised extruded aluminium body

Zinc plated steel screws

Brushes and sponge in expanded EPDM

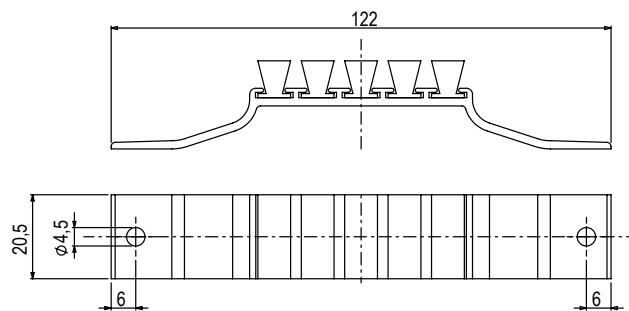
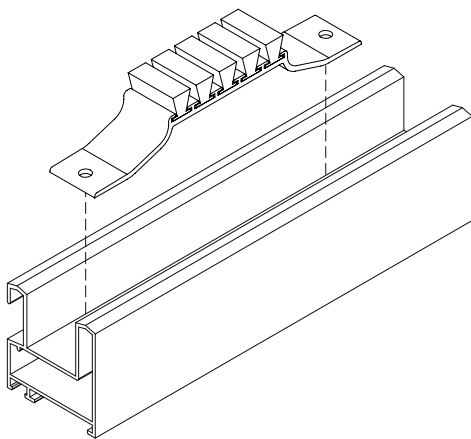

Item code	Description	Note	Base Raw	Anodised Elox	Painted	Trend/Gold Brass	Pieces per pack
01274	DUST-PROOF PLUG		X				100

SASH-CENTRING PLUG



Functions

Component that enables keeping the sliding sash guided while sliding.

[Online data sheet](#)



Technical features

The sash guiding plug stabilizes the sash and prevents the pulley from being able to come off the rail.

Materials

Black polyamide

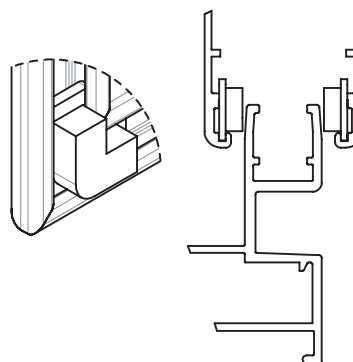
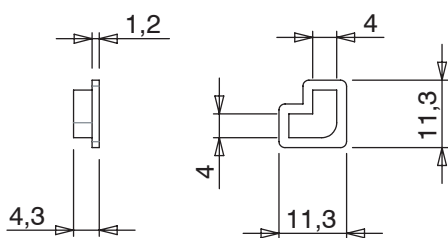

Item code	Description	Note	Base Raw	Anodised Elox	Painted	Trend/Gold Brass	Pieces per pack
01275	SASH-CENTRING PLUG		X				200

DUST-PROOF PLUG

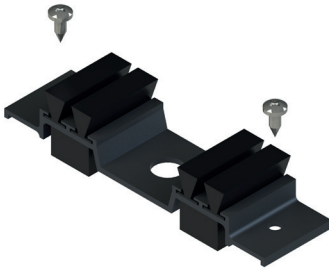

Functions

Component designed to prevent dust and water passing into the interior of the sliding door/window.

Online data sheet



Technical features

The dust cap fits to the upper and lower cross beams of the fixed frame using self-tapping screws.

The sponge fits snugly against the sash to prevent dust and water entering.

Materials

Black anodised extruded aluminium body

Zinc plated steel screws

Brushes and sponge in expanded EPDM

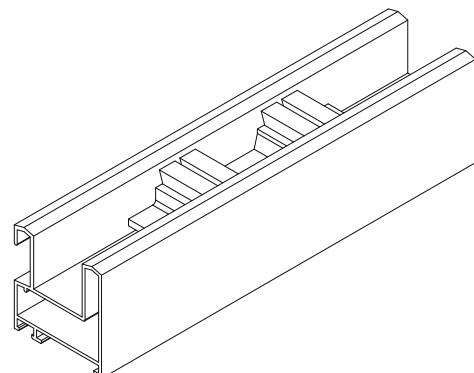
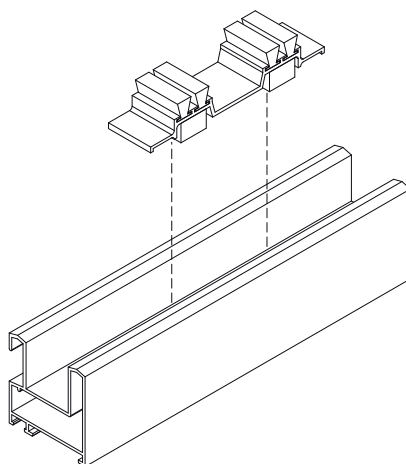
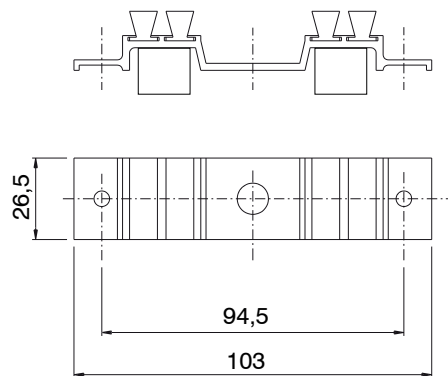

Item code	Description	Note	Base Raw	Anodised Elox	Painted	Trend/Gold Brass	Pieces per pack
02304	DUST-PROOF PLUG		X				100

DUST-PROOF GASKET AND UPRIGHTS PLUGS KIT



Functions

Package includes 4 central upright caps and 2 dust-proof covers for a window or sliding door made of aluminium.

[Online data sheet](#)



Technical features

The machining caps cover the machining on the central upright.
The dust cap fits to the upper and lower cross beams of the fixed frame using self-tapping screws.
The sponge fits snugly against the sash to prevent dust and water entering.

Materials

Black anodised extruded aluminium body
Brushes and sponge in expanded EPDM
Machining cover in black polyamide

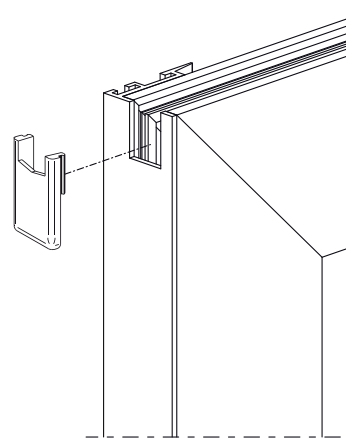
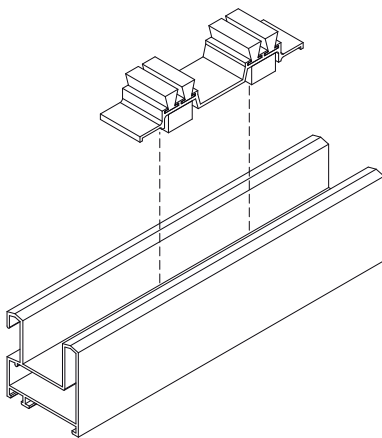
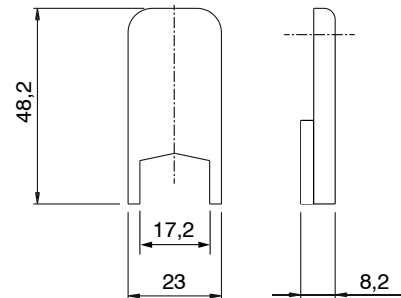
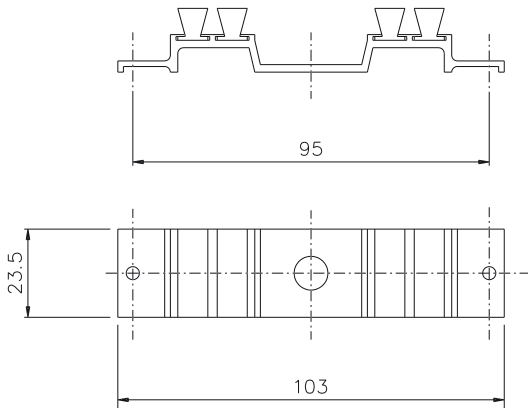
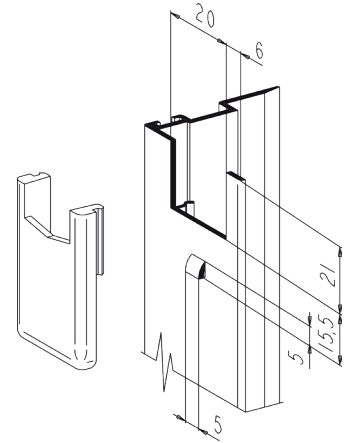

Item code	Description	Note	Base Raw	Anodised Elox	Painted	Trend/Gold Brass	Pieces per pack
03124	DUST-PROOF GASKET and UPRIGHT PLUGS KIT		X				100

DUST-PROOF GASKET AND UPRIGHT PLUGS KIT

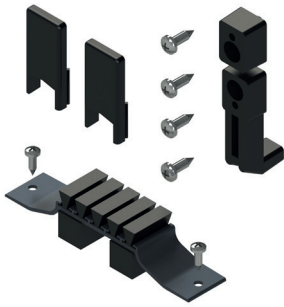

Functions

Package includes 4 central upright caps, 2 pairs of damping covers and 2 dust-proof covers for a window or sliding door made of aluminium.

Online data sheet



Technical features

The machining caps improve the appearance of the sash by covering the machining on the central upright.

The damper plugs, in addition to having a burglar-proof function, prevent the sash from slamming against the frame when closing.

The dust cap fits to the upper and lower cross beams of the fixed frame using self-tapping screws.

The sponge fits snugly against the sash to prevent dust and water entering.

Materials

Black anodised extruded aluminium body

Zinc plated steel screws

Brushes and sponge in expanded EPDM

Machining cover in black polyamide

Rubber damper plug

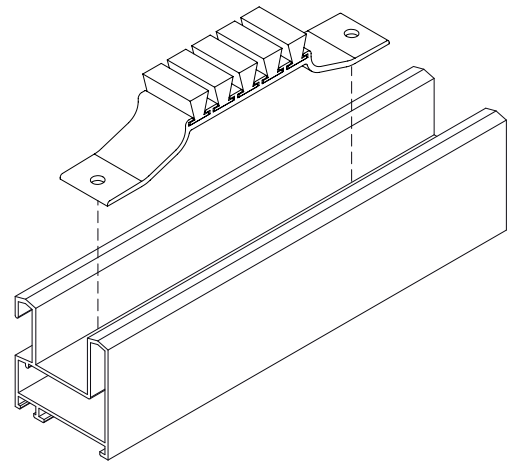
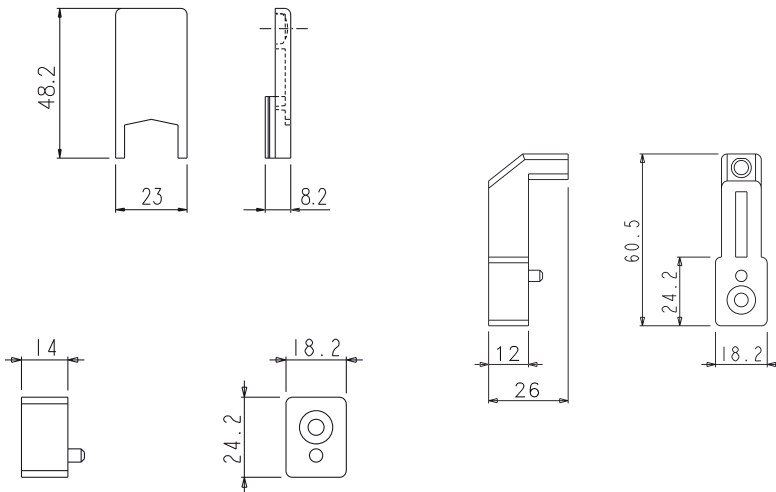
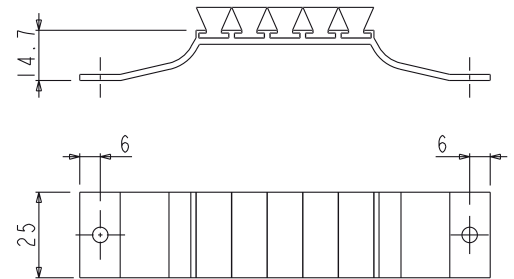

Item code	Description	Note	Base Raw	Anodised Elox	Painted	Trend/Gold Brass	Pieces per pack
03140	DUST-PROOF GASKET AND UPRIGHT PLUGS KIT		X				10

DUST-PROOF PLUGS

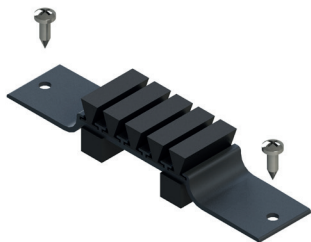

Functions

Designed to prevent dust and water passing into the interior of the sliding door/window.

Online data sheet



Technical features

The dust cap fits to the upper and lower cross beams of the fixed frame using self-tapping screws.

The sponge fits snugly against the sash to prevent dust and water entering.

Materials

Black anodised extruded aluminium body

Zinc plated steel screws

Brushes and sponge in expanded EPDM

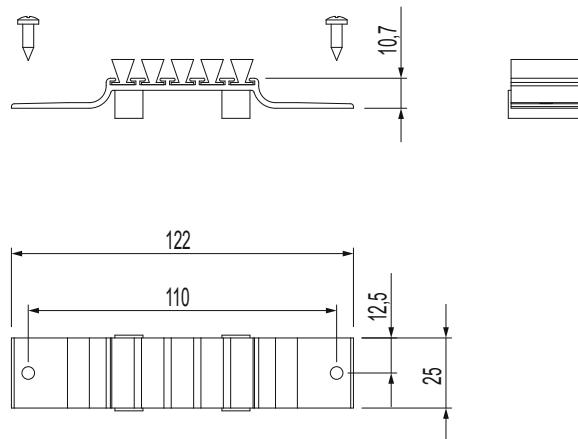
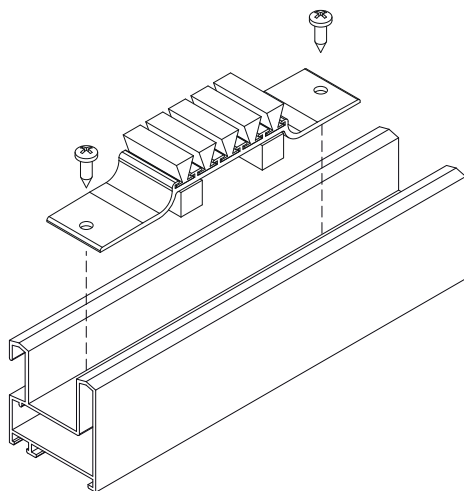

Item code	Description	Note	Base Raw	Anodised Elox	Painted	Trend/Gold Brass	Pieces per pack
03143	DUST-PROOF PLUGS		X				50

MACHINING COVERS



Functions

Cap covering the machining on the central upright of sliding sashes.
Fixing is by means of a self-tapping screw.

Online data sheet



Materials

Black polyamide cap
Zinc plated steel screw

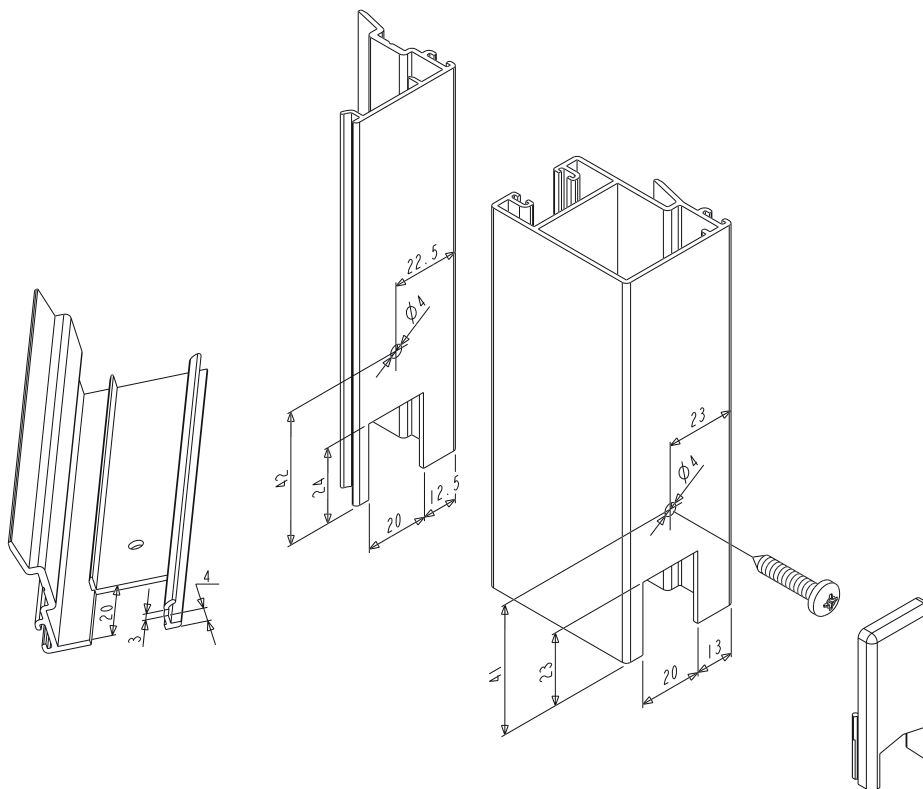

Item code	Description	Note	Base Raw	Anodised Elox	Painted	Trend/Gold Brass	Pieces per pack
03144	MACHINING COVERS		X				50

DUST-PROOF GASKET AND UPRIGHT PLUGS KIT



Functions

Package includes 4 central upright caps, 2 pairs of damping covers and 2 dust-proof covers for a window or sliding door made of aluminium.

Online data sheet



Technical features

The machining caps improve the appearance of the sash by covering the machining on the central upright.

The damper plugs, in addition to having a burglar-proof function, prevent the sash from slamming against the frame when closing.

The dust cap fits to the upper and lower cross beams of the fixed frame using self-tapping screws.

The sponge fits snugly against the sash to prevent dust and water entering.

Materials

Black anodised extruded aluminium body

Zinc plated steel screws

Brushes and sponge in expanded EPDM

Machining and damper plug in black polyamide

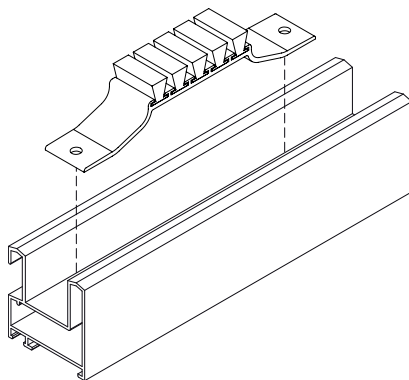
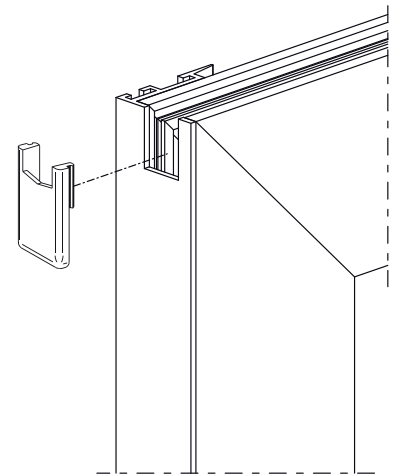
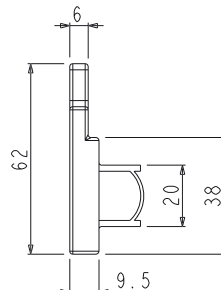
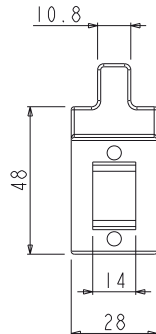
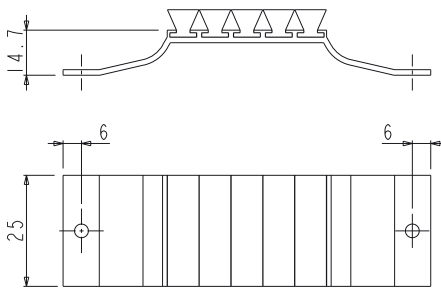
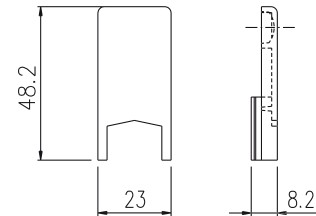

Item code	Description	Note	Base Raw	Anodised Elox	Painted	Trend/Gold Brass	Pieces per pack
03150	DUST-PROOF GASKET AND UPRIGHT PLUGS KIT		X				10

DUST-PROOF GASKET AND UPRIGHTS PLUGS KIT



Functions

Package includes 4 central upright caps and 2 dust-proof covers for a window or sliding door made of aluminium.

Online data sheet



Technical features

The machining caps improve the appearance of the sash by covering the machining on the central upright.

The dust cap fits to the upper and lower cross beams of the fixed frame using self-tapping screws.

The sponge fits snugly against the sash to prevent dust and water entering.

Materials

Black anodised extruded aluminium body

Zinc plated steel screws

Brushes and sponge in expanded EPDM

Machining cover in black polyamide.

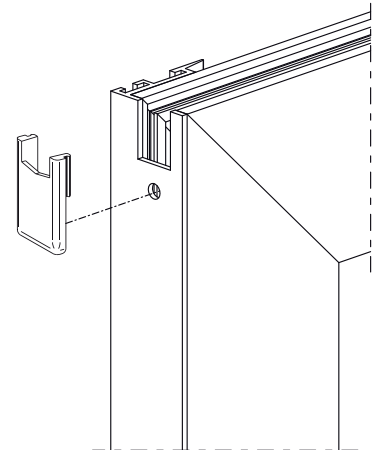
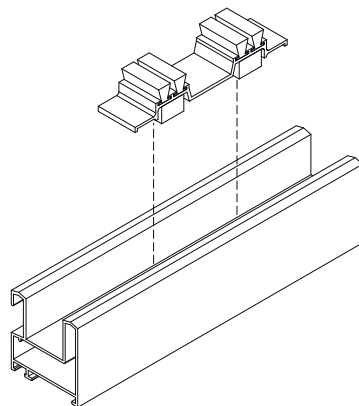
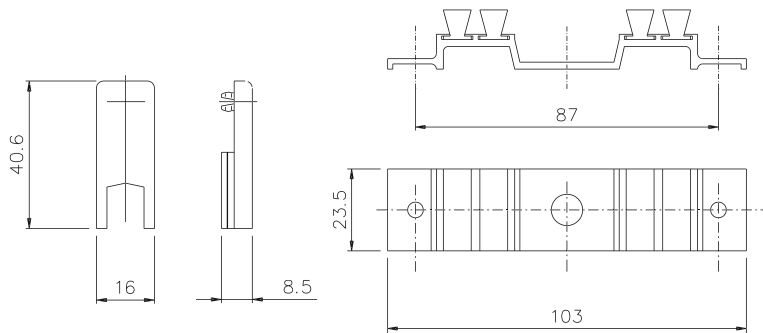

Item code	Description	Note	Base Raw	Anodised Elox	Painted	Trend/Gold Brass	Pieces per pack
03166	DUST-PROOF GASKET and UPRIGHT PLUGS KIT		X				100



2-SASH SLIDER PLUGS KIT

Functions

Package includes 4 central upright caps, 2 pairs of damping covers, 16 alignment corner joints and 2 dust-proof covers for a window or sliding door made of aluminium.

[Online data sheet](#)



Technical features

The machining caps improve the appearance of the sash by covering the machining on the central upright.

The damper plugs, in addition to having a burglar-proof function, prevent the sash from slamming against the frame when closing.

The dust cap fits to the upper and lower cross beams of the fixed frame using self-tapping screws.

The sponge fits snugly against the sash to prevent dust and water entering.

The alignment brackets allow strengthening the junction of the fins.

Materials

Black anodised extruded aluminium body

Zinc plated steel screws

Brushes and sponge in expanded EPDM

Cover for machining, alignment corner joint and damper in black polyamide.

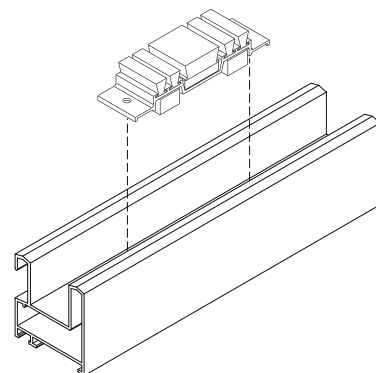
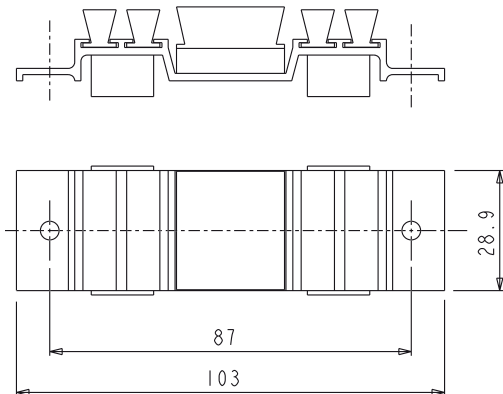
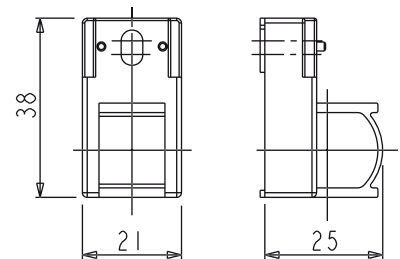
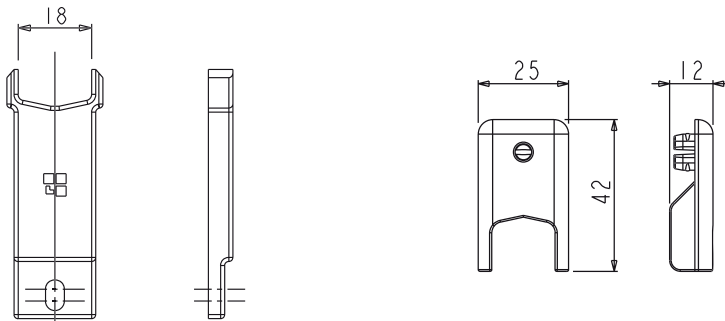
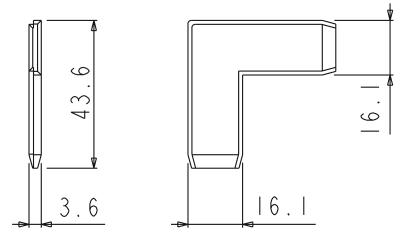

Item code	Description	Note	Base Raw	Anodised Elox	Painted	Trend/Gold Brass	Pieces per pack
03185N	2-SASH SLIDER PLUGS KIT		X				50

DUST-PROOF GASKET AND UPRIGHTS PLUGS KIT



Functions

Package includes 4 central upright caps, 8 sash guide plugs and 2 dust-proof covers for a window or sliding door made of aluminium.

Online data sheet



Technical features

The machining caps improve the appearance of the sash by covering the machining on the central upright.
 The sash guiding plugs stabilize the sash and prevent the pulley from being able to come off the rail.
 The dust cap fits to the upper and lower cross beams of the fixed frame using self-tapping screws.
 The sponge fits snugly against the sash to prevent dust and water entering.

Materials

Black anodised extruded aluminium body
 Brushes and sponge in expanded EPDM
 Cover for machining and sash guide in black polyamide

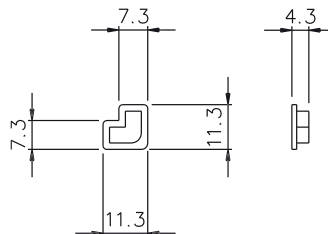
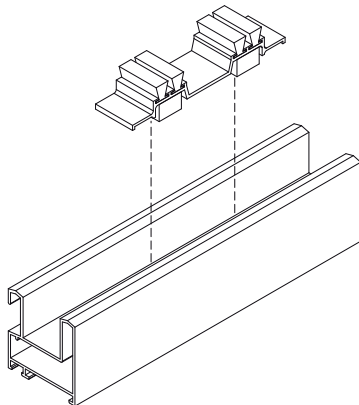
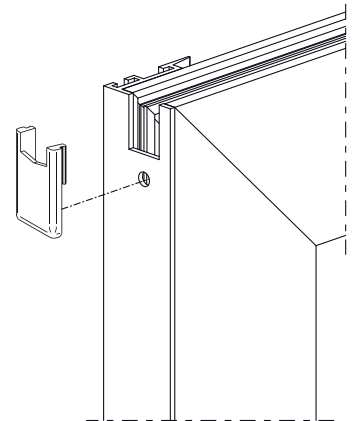
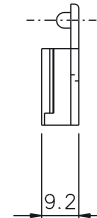
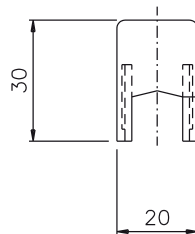
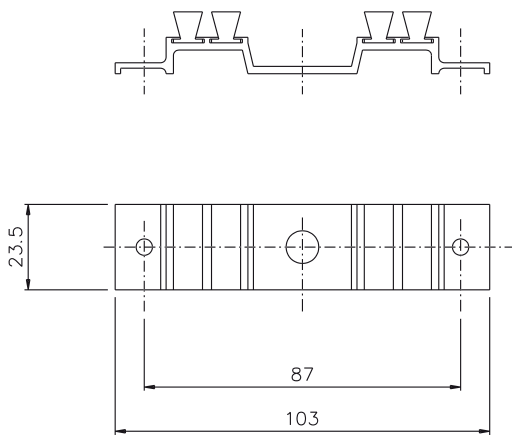
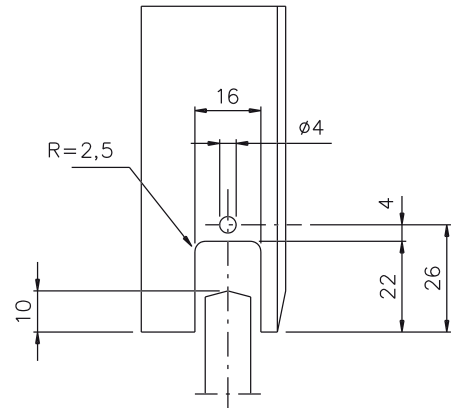

Item code	Description	Note	Base Raw	Anodised Elox	Painted	Trend/Gold Brass	Pieces per pack
03194	DUST-PROOF GASKET and UPRIGHT PLUGS KIT		X				100

DUST-PROOF PLUG



Functions

Component designed to prevent dust and water passing into the interior of the sliding door/window.

Online data sheet



Technical features

The dust cap fits to the upper and lower cross beams of the fixed frame using self-tapping screws.

The sponge fits snugly against the sash to prevent dust and water entering.

Materials

Black anodised extruded aluminium body

Zinc plated steel screws

Brushes and sponge in expanded EPDM

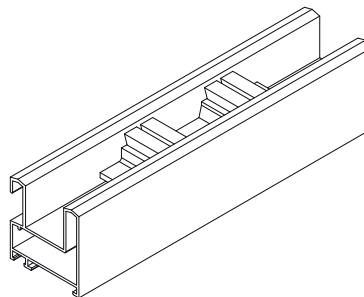
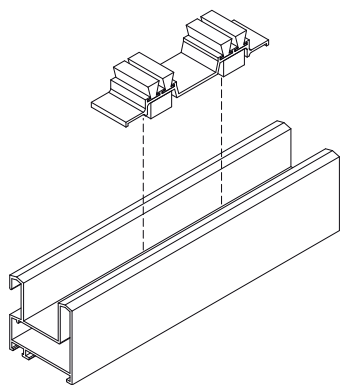
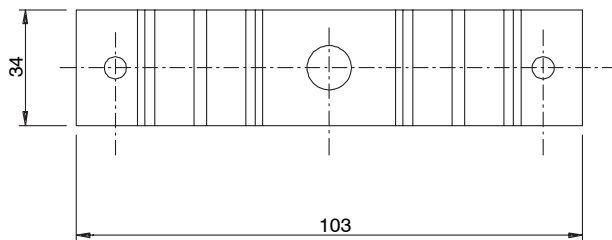
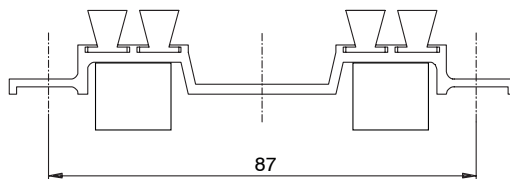

Item code	Description	Note	Base Raw	Anodised Elox	Painted	Trend/Gold Brass	Pieces per pack
03314	DUST-PROOF PLUG	L= 34 mm	X				200



2-SASH SLIDER KIT

Functions

Package includes 4 central upright caps, 2 dust-proof covers and a damping cover for a window or sliding door made of aluminium.

Online data sheet



Technical features

The machining caps improve the appearance of the sash by covering the machining on the central upright.

The dust cap fits to the upper and lower cross beams of the fixed frame using self-tapping screws.

The sponge fits snugly against the sash to prevent dust and water entering. The damper plug, in addition to having a burglar-proof function, prevents the sash from slamming against the frame when closing.

Materials

Dust-proof cover body in black anodized extruded aluminium

Brushes and sponge in expanded EPDM

Screws and grub screws in zinc plated steel

Machining and damper plugs in black polyamide

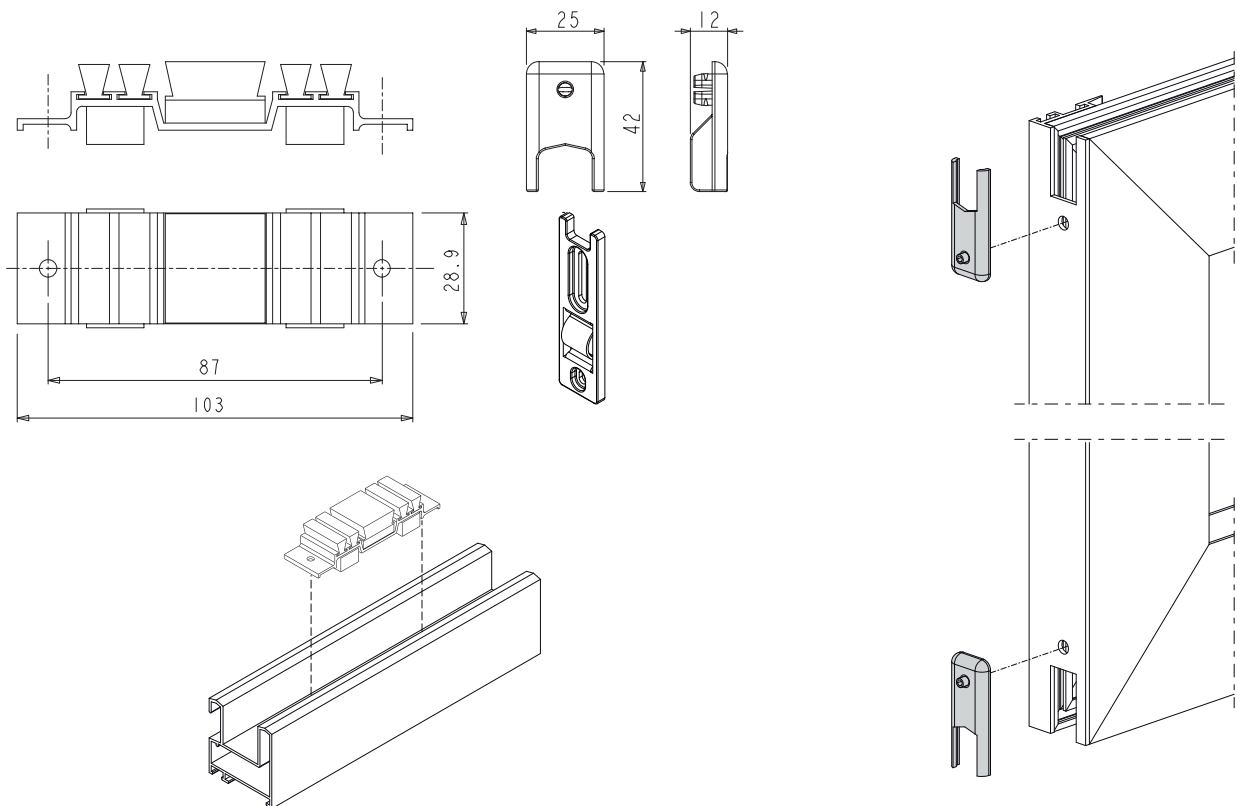

Item code	Description	Note	Base Raw	Anodised Elox	Painted	Trend/Gold Brass	Pieces per pack
03384	2-SASH SLIDER KIT		X				50

MACHINING COVER

Functions

Cap covering the machining on the central upright of sliding sashes.

Online data sheet



Technical features

Fixing is by means of a self-tapping screw.

Materials

Black polyamide cap
Zinc plated steel screw

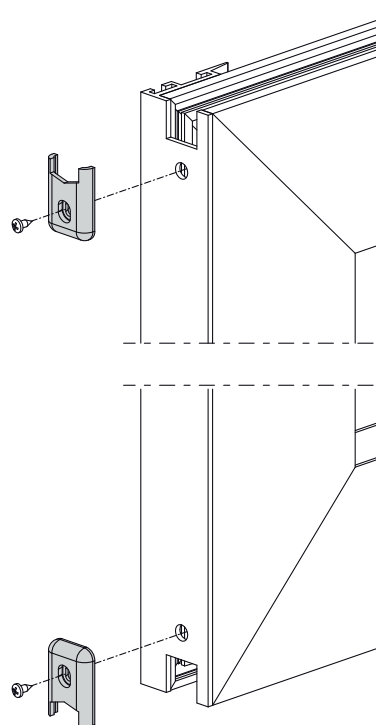
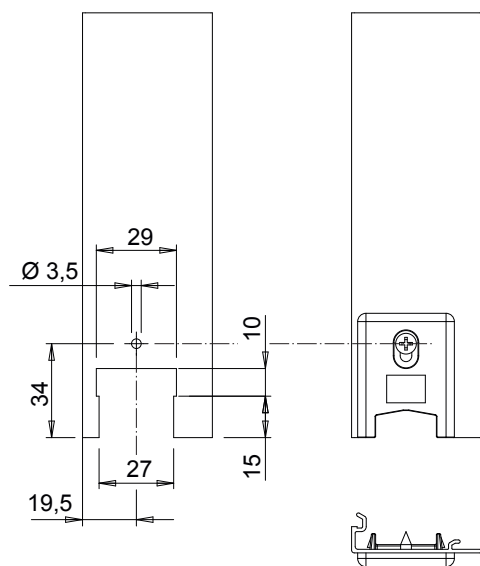
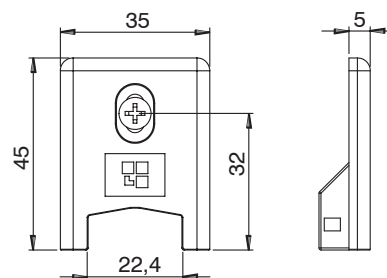

Item code	Description	Note	Base Raw	Anodised Elox	Painted	Trend/Gold Brass	Pieces per pack
03462	MACHINING COVER		X				200

DUST-PROOF PLUG

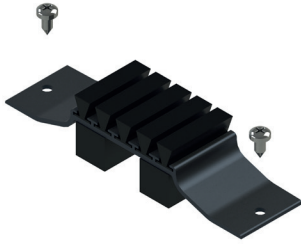

Functions

Component designed to prevent dust and water passing into the interior of the sliding door/window.

Online data sheet



Technical features

The dust cap fits to the upper and lower cross beams of the fixed frame using self-tapping screws.

The sponge fits snugly against the sash to prevent dust and water entering.

Materials

Black anodised extruded aluminium body

Zinc plated steel screws

Brushes and sponge in expanded EPDM

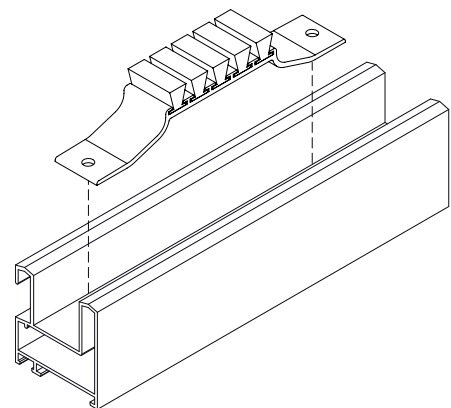
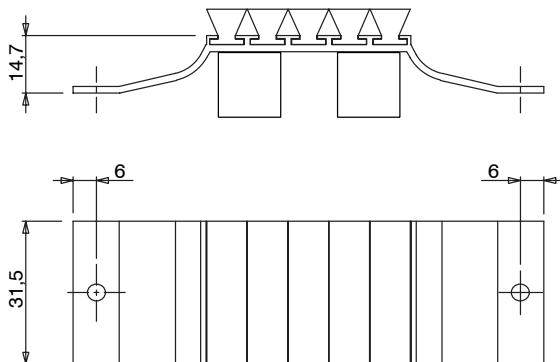

Item code	Description	Note	Base Raw	Anodised Elox	Painted	Trend/Gold Brass	Pieces per pack
03467	DUST-PROOF PLUG		X				100

MACHINING COVER



Functions

Cap covering the machining on the central upright of sliding sashes. Fixing takes place by snap-fitting.

[Online data sheet](#)



Materials

Black polyamide cap

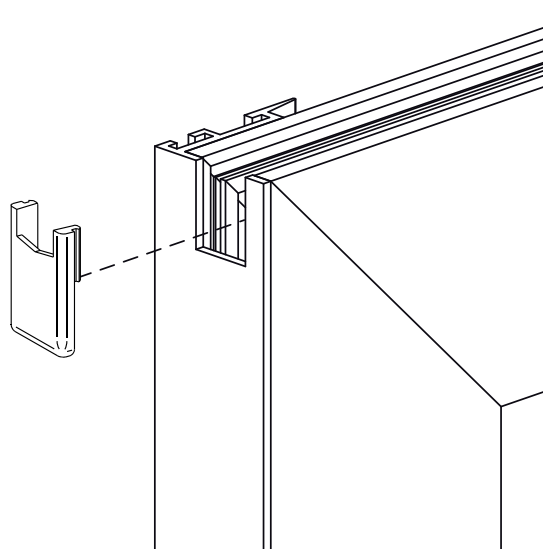
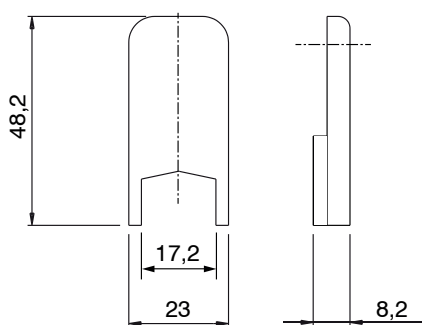

Item code	Description	Note	Base Raw	Anodised Elox	Painted	Trend/Gold Brass	Pieces per pack
03479	MACHINING COVER		X				100

MACHINING COVER



Functions

Cap covering the machining on the central upright of sliding sashes.

Online data sheet



Technical features

Fixing is by means of a grub screw.

Materials

Black polyamide cap

Stainless steel grub screw

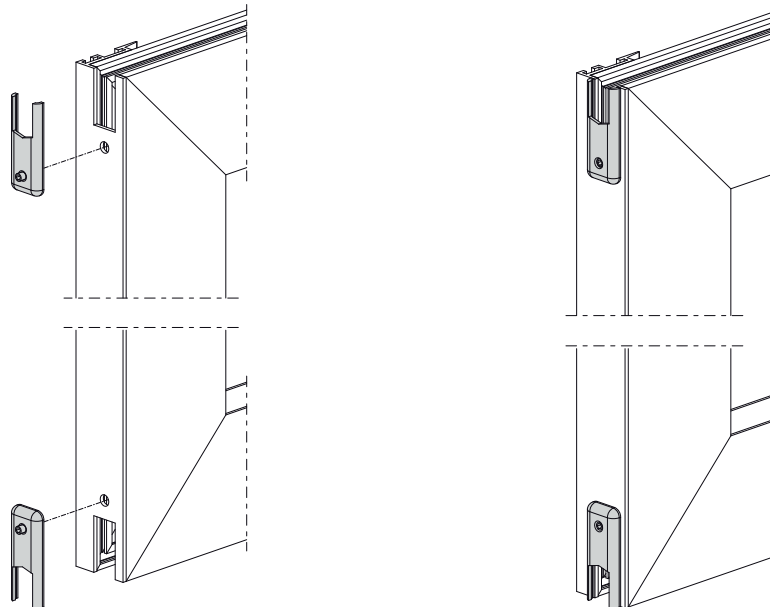
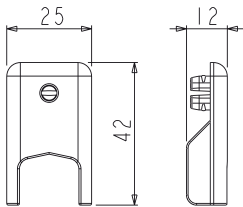

Item code	Description	Note	Base Raw	Anodised Elox	Painted	Trend/Gold Brass	Pieces per pack
03485	MACHINING COVER		X				100

MACHINING COVER



Functions

Component designed to prevent dust and water passing into the interior of the sliding door/window.

Online data sheet



Technical features

The dust cap fits to the upper and lower cross beams of the fixed frame using self-tapping screws.

The sponge fits snugly against the sash to prevent dust and water entering.

Materials

Black anodised extruded aluminium body

Zinc plated steel screws

Brushes and sponge in expanded EPDM

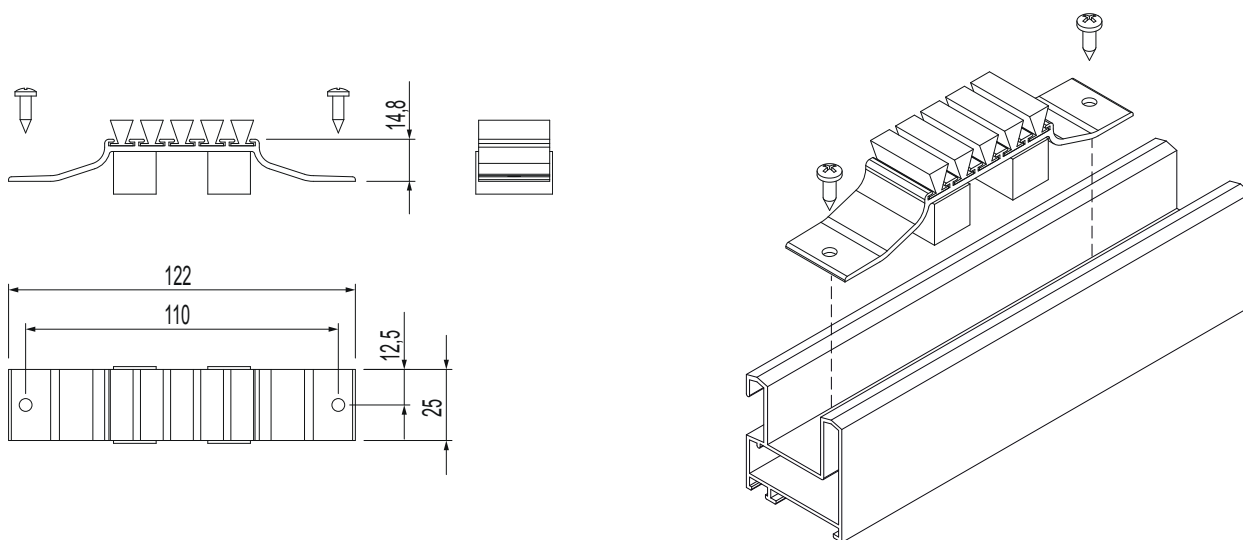

Item code	Description	Note	Base Raw	Anodised Elox	Painted	Trend/Gold Brass	Pieces per pack
03491	MACHINING COVER		X				100

MACHINING COVER



Functions

Cap covering the machining on the central upright of sliding sashes. Fixing is by means of a grub screw.

Online data sheet



Materials

Black polyamide cap
Stainless steel grub screw

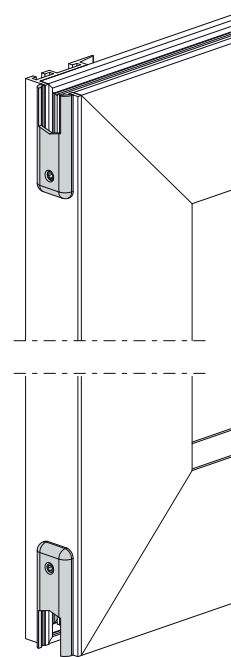
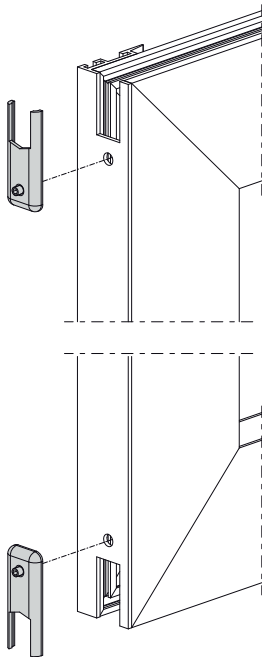

Item code	Description	Note	Base Raw	Anodised Elox	Painted	Trend/Gold Brass	Pieces per pack
03507	MACHINING COVER		X				200

BUSHES



Functions

Component which pressure fits to the bed of an aluminium window or a sliding aluminium door to enable the water to run off.

Materials

Black polyamide

Online data sheet



02367

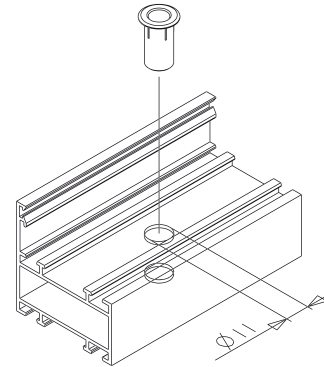
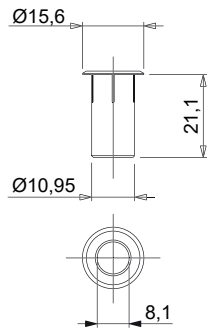
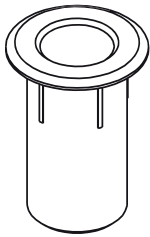

03156

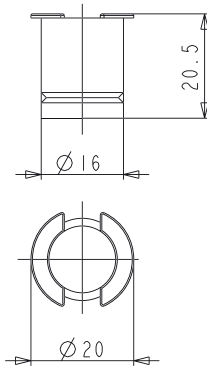
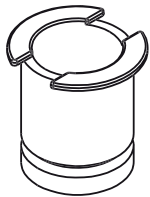

03196

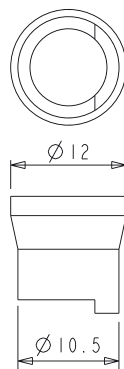
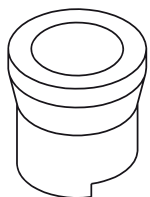

In some series, it is necessary, during assembly, to remove the terminal part at the predetermined break line.



Item code	Description	Note	Base Raw	Anodised Elox	Painted	Trend/Gold Brass	Pieces per pack
02367	PALLET DRAINAGE BUSH		X				500
03156	WATER DRAINAGE BUSH		X				100
03196	WATER DRAINAGE BUSH		X				100

CYLINDERS AND KEYS



Functions

Spare component which enables the fastening function of the PRATICA DUO and BRIO KEY handles.

Online data sheet



Technical Features

The cylinder can be easily applied on the PRATIKA DUO and BRIO KEY handles with a grub screw.

The cylinder allows an excellent number of combinations and the possibility of having systems with the same key (KA) or master key (MK).

Materials

Brass body cylinder
Peg plate in galvanized zamak
Stainless steel grub screw
Key blank in nickel-plated brass

03061

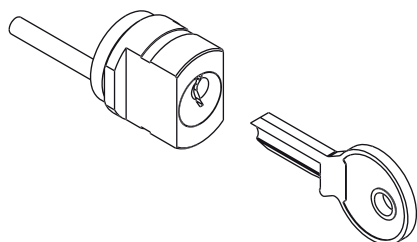

03062

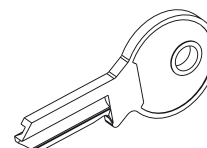

Item code	Description	Note	Base Raw	Anodised Elox	Painted	Trend/Gold Brass	Pieces per pack
03061	CYLINDER WITH KEYS		X				10
03062	BLANK KEY FOR PRATIKA/BRIO		X				100

NYLON PARTS



Functions

Hardware to be used on sliding casements with sealing, joining or adjustment function.

Online data sheet



01239

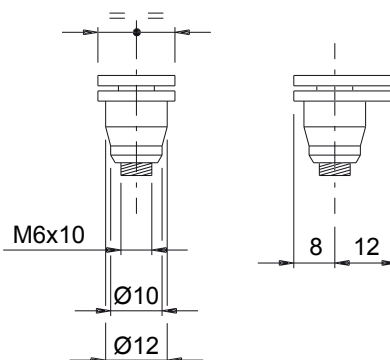
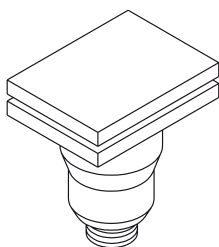

03155

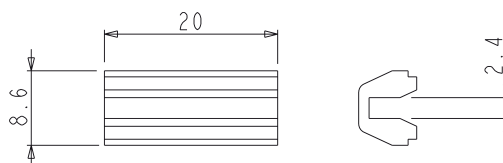
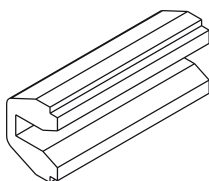

Item code	Description	Note	Base Raw	Anodised Elox	Painted	Trend/Gold Brass	Pieces per pack
01239	GLASS ADJUSTMENT PLUG		X				100
03155	CLIP FOR HOLDING CABLE COVER		X				50



GIESSE

CHIC 150

**HIGHER LOAD CAPACITY.
STILL INVISIBLE.**

- 180° opening
- 3D adjustment
- Quick and easy assembly
- Maximum corrosion resistance
(Grade 5 - EN 1670)
- Designed and manufactured in Italy
- Sustainable packaging
- Environmental Product Declaration

 **EPD**®
THE INTERNATIONAL EPD® SYSTEM



U0940301
10/2024