



Automations

Chain, Rod and Rack
actuators

 **GIESSE**

Index

Chain Actuator	8
Varia Tube	
Tube Lock	
Varia SlimPlus / Varia Slim Plus syncro	
Varia Slim / Varia Slim syncro / Varia Slim radio	
Remote-control device	
Heated rain detector	
Slim Lock	
Varia Slim Base	
Varia Slim Small	
Varia 24 V / Varia Uni	
Bottom-hung multipoint kit	
Rod Actuator	38
Rod Actuator ST450	
Rack Actuator	40
RackMax 450	
RackMax 650	
Control Units	48
Shev RWA	
Power BT / Power AT Control Units	

RWA SYSTEMS

SMOKE AND HEAT EVACUATION

Statistical data has shown that almost all building-fire-related fatalities are caused by poisoning as a result of inhaling smoke and toxic gases rather than thermal damage due to high temperatures. When fires occur on building premises, smoke spreads throughout the rooms, causing considerable damage to the structure itself and the equipment inside. Bringing the temperature down or delaying temperature increase not only helps to preserve the stability of the structure but also makes it easier for firefighters to see their way around, keeps the air cooler at head level and retards the spread of flames sideways.

The primary concern of any fire-fighting team is to stop smoke from building up in the rooms and reaching escape routes, creating safe areas where people can survive.

The safety system must be activated automatically, ensuring that all apertures are unobstructed so that heat and smoke can get out, thus freeing escape routes so people can reach areas with clean fresh air. This very same system regulates air changes in rooms on a daily basis, improving occupants' quality of life and general health.

RWA actuators mean you only have to install one single actuator for both smoke evacuation and natural ventilation.

GIESSE RWA actuators have been designed and tested to be used with integrated systems for smoke and heat evacuation in compliance with the European Standard EN12101-2.

NRWG certification determines the test procedures which the various parts of the system undergo, such as windows, automations, detection devices and the central control and monitoring unit. Even construction materials are subject to this certification.

Building structure should be a prime consideration when creating evacuation systems and deciding where to put them because of the need for outlets on vertical walls, roofs, shafts, etc.

GIESSE produces remote-controllable electric actuators which move windows and ventilation openings in the event of fire.

Using an integrated smoke-and-heat evacuation system in conjunction with the actuators will protect people's lives. When smoke and hot air are released from rooms, chances of survival increases.

Creating a smoke-free space low down at ground level, **freeing stairwells and corridors and diminishing deadly fumes** are all ways to help occupants to quickly identify escape routes and make it easier for emergency-rescue services to gain access. This is why the actuators have been designed and tested for use with integrated systems and frames for extracting smoke and heat in compliance with European Standard EN12101-2.

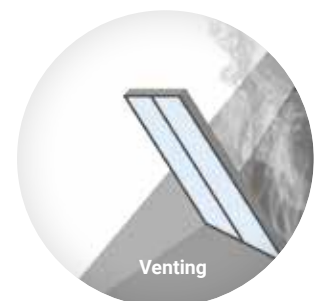
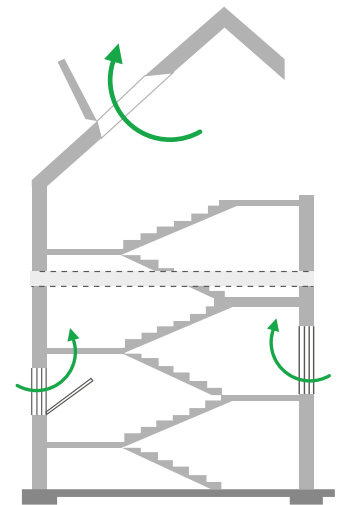

CHOOSE YOUR SOLUTIONS

Windows come in a variety of types, sizes and weights. Sometimes weather factors can be such that significant force is required to open windows.

In other circumstances, electronic-control devices are necessary for reasons of practicality or security so windows can be opened or closed automatically. Before an actuator is installed on a window, checks must be run to ensure that it is suited to the task. This is particularly important when smoke and heat protection is required.

Formulas for calculating the push or pull force required to open a window.

Finding out how much force is required to move the window is the first step in determining which automation is the right one.

An initial check can be made by using the formulas beneath. However, they do not take into account the action of external agents on the window, such as friction, air currents, low-pressure areas, snow and wind.

Calculation for determining the force (Newton=N) required for top-hung and bottom-hung windows and doors:

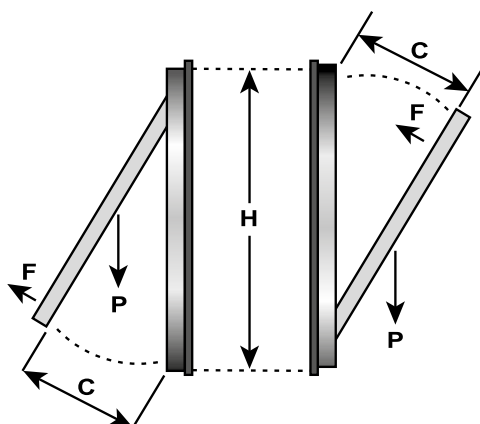

$$F = \frac{P}{2} \times \frac{C}{H} = \text{kg F}$$

$$\text{Kg F} \times 9,81 = \text{N}$$

Calculation for determining the force (Newton=N) required for horizontal domes and dormer windows:

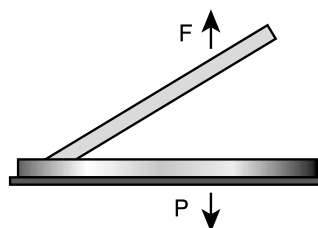

$$F = \frac{P}{2} = \text{kg F}$$

$$\text{Kg F} \times 9,81 = \text{N}$$

1 kg = 9,81 N

1 N (Newton) = 0,102 kg

F: force required to open and close - kg













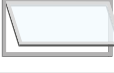

P: window weight (only movable part) - kg

C: window opening stroke (actuator stroke) - mm

H: window height - mm

Theoretical calculation (does not take into account friction of the hinges, wind thrust and weight of snow).

Giessere actuators

Type of Automation	Chains					Rod	Racks	
Model	Varia Tube	Varia Slim Varia Slim Plus	Varia Slim Base	Varia Slim Small	Varia UNI 230 V CA Varia 24 V CC	ST 450	RackMax 450	RackMax 650
Thrust Force	350 N	300 N	250 N	200 N	150 N	450 N	450 N	650 N
Drive Force					300 N			
Bottom-Hung		✓	✓	✓	✓	✓		
Bottom-Hung Width > 1.6 m		✓ Syncro Version	✓ Syncro Version			✓ Varia UNI 2 pcs		
In-Line Bottom-Hung (Ribbon development) Max 3 windows with width < 1 m		✓	✓	✓	✓	✓		
Top-Hung		✓	✓	✓	✓	✓	✓	✓
Top-Hung And Shed windows Width > 1.6 m		✓ Syncro Version	✓ Syncro Version			✓ Varia UNI 2 pcs		✓ Add. Drive unit
In-Line Top-Hung And Shed windows		✓	✓	✓		✓	✓	✓
Skylights		✓	✓	✓				
Hopper		✓	✓	✓		✓	✓	✓
Small Roof Vents		✓	✓	✓		✓	✓	✓
Small In-Line Roof Vents Width < 1 m		✓	✓	✓		✓	✓	✓
Large Roof Vents Max 110 Kg with width > 1.8 m								✓ Add. Drive unit
Vertical Sunblinds						✓	✓	✓
Jalousie Window							✓	✓
Parallel Opening		✓ Syncro Version	✓ Syncro Version			✓ Varia UNI 2 pcs		

VARIA TUBE

Chain actuator

A sophisticated electronic system with a microprocessor means that the actuator can be installed not only on industrial premises, but also integrated into domotic system to which it can be easily connected via existing devices and made to transmit an "open/close window" signal.



Smoke and heat
evacuation



Natural ventilation



Power control over the entire stroke.



Remarkably quiet (41 dB) while maintaining high power standards.



Easy to install thanks to rapid release support brackets and fixing brackets (patented).



Strokes can be selected by means of dip-switches.



Syncro technology (patented) allows for up to 8 Varia Tubes to be connected together.



Relax and Soft-Stop function for resting mechanical parts after every stroke-end.



Reliability tested via 10,000 cycles at maximum load.



Go to the technical data sheet



High resistance to corrosion and diverse weather conditions.

Code	Description	Code	Description
07875	VARIA TUBE 230 V - 300	07804	VARIA TUBE RWA 24 V - 300
07876	VARIA TUBE 230 V - 600	07805	VARIA TUBE RWA 24 V - 600
07877	VARIA TUBE 230 V - 800	07806	VARIA TUBE RWA 24 V - 800
07878	VARIA TUBE 230 V - 1000	07807	VARIA TUBE RWA 24 V - 1000
07896	VARIA TUBE Syncro 230 V - 300	07815	VARIA TUBE RWA Syncro 24 V - 300
07897	VARIA TUBE Syncro 230 V - 600	07816	VARIA TUBE RWA Syncro 24 V - 600
07898	VARIA TUBE Syncro 230 V - 800	07817	VARIA TUBE RWA Syncro 24 V - 800
07899	VARIA TUBE Syncro 230 V - 1000	07818	VARIA TUBE RWA Syncro 24 V - 1000

● 000 - Anodised silver

Varia Tube - Technical data

TABLE OF FORCE-STROKE RELATIONSHIP

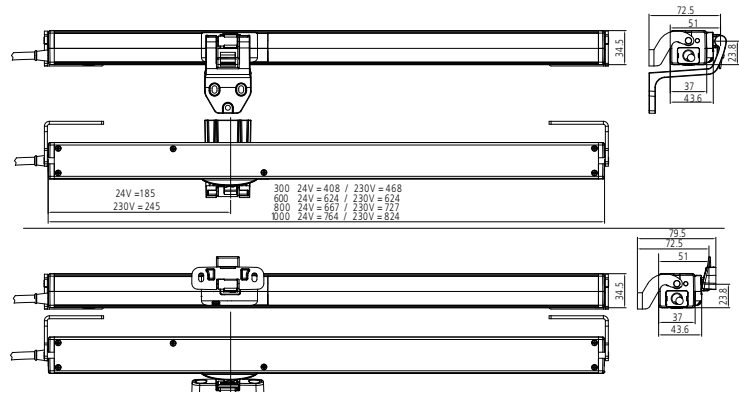
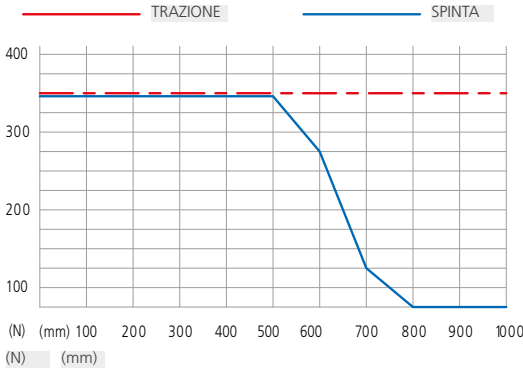

VARIA TUBE	230 V CA	RWA 24 V CC	Syncro 230 V CA	RWA Syncro 24 V CC
Pull force	350 N			
Push force	350 N (see strength diagram)			
Variable strokes	300 (100, 175) mm - 600 (400, 500) mm - 800 (600, 700) mm - 1000 (800, 900) mm			
Syncro3 technology (patented)	No	No	Yes	Yes
Power-supply voltage	110÷230 V~(AC)	24 V=(DC)	110÷230 V~ (AC)	24 V=(DC)
Frequency	50/60 Hz	-	50/60Hz	-
Current absorbed at nominal load	0.23 A (230 V)	0.80 A	0.23 A (230 V)	0.80 A
Power absorbed at nominal load	29 W	19.2 W	29 W	19.2 W
Speed	11 / 9.6 mm/s		11 / 9.6 mm/s	
Stroke duration at nominal charge (Open)	Stroke 300/600/800/1,000 = 28 / 54 / 72 / 90 s			
Stroke duration at nominal charge (Close)	Stroke 300/600/800/1,000 = 36 / 67 / 88 / 109 s			
Double electrical insulation	YES	L.V.	YES	L.V.
Service type	S2 of 3 min			
Operating temperature	-20 °C ÷ +70 °C			
Degree of protection for electrical devices	IP32			
Soft Stop / Start	YES			
Relax function	YES			
Self-learning frame rebated overlap	Self-determination of the position			
Parallel connection	YES			
Power-supply cable type and length	H05VV-F - 2 m		FRR/2 - 2.5 m	
Opening stroke-end setting	Electronic via dip-switches			
Closing stroke-end setting	Upon absorption of power			
Overload protection	Upon absorption of power			
Dimensions for 230 V (strokes 300/600/800/1,000)	34.6x37 L=468/624/727/824 mm			
Dimensions for 24 V (strokes 300/600/800/1,000)	34.6x37 L=408/624/667/764 mm			
Static holding force	2000 N			
Weight	0.9/1.4/1.8/2.2 Kg	0.8/1.3/1.7/2.1 Kg	0.9/1.4/1.8/2.2 Kg	0.8/1.3/1.7/2.1 Kg
Supplied brackets	Only frame brackets included. Sash bracket to be ordered separately.			
Connection with Tube Lock	NO	YES	NO	YES

The data provided in these illustrations is non-binding and subject to change, even without advance notice.

Varia Tube - Accessories

	Code	Description	Model
	05911	Sash bracket special for Varia, Slim Plus, Varia Slim and Varia Slim Base (to be ordered separately)	Metal H Support brackets 45 mm (cp)
	05921	Bottom-hung bracket (to be ordered separately)	Zamak sash bracket
	05922	Top-hung frontal bracket (to be ordered separately)	Zamak sash bracket
	05923	Top-hung horizontal bracket (to be ordered separately)	Zamak sash bracket
	05920	Spare parts - Top-hung horizontal bracket (cp)	Steel sash bracket
	05924	Spare parts - Rapid fixing clip	Steel rapid fixing clip



TUBE LOCK

Electric lock

Tube Lock is an electric lock specially designed to automatically open/close the multi-point locking system of top-hung, bottom-hung and parallel windows in conjunction with Varia Tube 24 V chain actuators.

The presence of locking points around the window significantly increases its air, water and wind tightness.

Tube Lock is small and unobtrusive (25x26 mm) with recessed installation inside a slot in the window frame and no impact on visual design.

Tube Lock operates quietly and comes equipped with advanced electronics. It works in conjunction with Varia Tube 24 V actuators: upon the opening signal, the lock releases the locking points before the actuator goes into action; conversely, it blocks the locking points as soon as the window is closed.

The push/pull force (600 N – 850 N at start) ensures high operational reliability even when the locking points are numerous.



Quiet and powerful

TESTED
10,000

Reliability tested via 10,000 cycles at maximum load



Syncro technology (patented) allows for up to 8 Tube Locks and Varia Tube 24 V actuators to be connected together



Natural ventilation

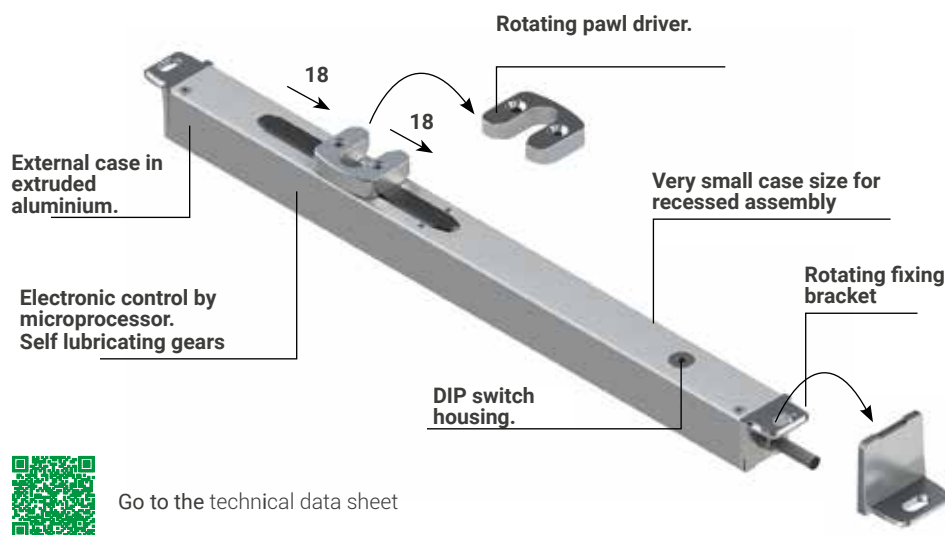

Go to the technical data sheet

Code Description

07809 TUBE LOCK 24 V

000 - Anodised silver

Tube Lock - Technical data

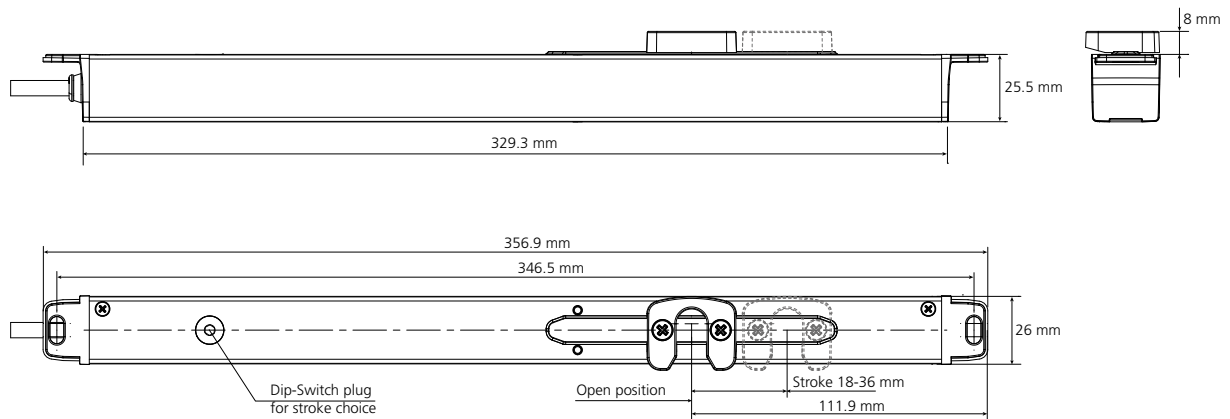

TUBE LOCK 24 V CC	07809
Push and pull force	600 N at work- 850 N at start
Stroke	18 mm / 36 mm
Power-supply voltage	24 V cc
Current absorbed at nominal load	0.85 A during opening/closing - 1.2 A for amperometric block
Power absorbed at nominal load	~ 20 W
No-load speed	5 mm/s
Maximum no-load stroke duration	4 s (18 mm) – 7.2 s (36 mm)
Double electrical insulation	Very low tension
Duty rate	30%
Service	S2 - 1 minute
Case material	Aluminium alloy extrude
Operating temperature	-20 °C ÷ +70 °C
Degree of protection for electrical devices	IP 40
Opening/closing stroke-end setting	Electronically set
Operating with chain actuators	Selectable
Operating without chain actuators	Selectable
Silicone cable	3 x 0.5 mm ² - 2.00 m
Overload protection during opening/closing phases	Supply cut due to power overload
Dimensions	25.5 x 25.5 x 357 mm
Weight	0.56 kg
Connectable to	Varia Tube 24 V DC Varia Tube Syncro 24 V DC

The data provided in these illustrations is non-binding and subject to change, even without advance notice.

VARIA SLIM PLUS

Chain actuator

300 N stroke adjustable up to 500 mm

Varia Slim Plus is a sleek combination of design, high performance levels, quality and safety. The units are available in 230 V and in the low voltage 24-V CC version. The casing of Varia Slim Plus comes in aluminium and has a distinctive robust design.

Frame support brackets are included with the product. Sash brackets to be ordered separately



Natural ventilation



Go to the technical data sheet

ALU Body is made of die-cast aluminium.



Support brackets in zamak.



Easy to install via quick-coupling of the actuator to the quick-fit frame brackets (without screws). Patented system.



Choice of 3 different chain strokes by means of dip-switches.



Quick-release from the window for even easier cleaning.



Relax and Soft-Stop function for resting mechanical parts after every stroke-end.



Code	Description
------	-------------

07882	VARIA SLIM PLUS 230 V
-------	-----------------------

Sash bracket to be ordered separately.

○ 410 - RAL 9010 ● 500 - RAL 9005 ● 970 - RAL 9006

VARIA SLIM PLUS SYNCRO Synchronized actuators

Varia Slim Plus Syncro is composed of a couple of chain actuators with the same technical features of Varia Slim Plus. They are able to work in perfect synchrony. In fact, the Syncro version gives instant control over the force, speed and resistance of each actuator via an encoder reading of how the individual motors are functioning.

Syncro3 software allows for the direct connection of up to 8 actuators without the need for external synchronisation control units. The number of actuators synchronised varies according to window size, weight and type. For windows over 1600 mm in width, two actuators are recommended to ensure correct movement and guarantee perimeter sealing. An additional actuator is recommended for every additional 1,600 mm in width.

Frame support brackets are included with the product. Sash brackets to be ordered separately.



Note: Syncro items are made up of two actuators (one couple).





Go to the technical data sheet

ALU Body is made of die-cast aluminium

 Support brackets in zamak.

 Easy to install via quick-coupling assembly onto the support brackets without the need for screws or fastening components (patented system).

 Choice of 3 different chain strokes by means of dip-switches

 Quick-release from the window for even easier cleaning

 Relax and Soft-Stop function for resting mechanical parts after every stroke-end.



Code	Description
07883	VARIA SLIM PLUS SYNCRO 230 V
07881	VARIA SLIM PLUS SYNCRO 24 V

Sash bracket to be ordered separately.

 410 - RAL 9010

Varia Slim Plus & Slim Plus Syncro - Technical data

Specifications

Electric linear actuator: double-row four-link articulated chain enclosed in an appropriate aluminium casing and designed to move awning windows, hopper windows, dormer windows and light domes. The actuator has a push and pull force of 300 N and is designed to function at a voltage of 110/230 V AC 50/60 Hz. The device comes equipped with universal swing support brackets that are quick-coupling

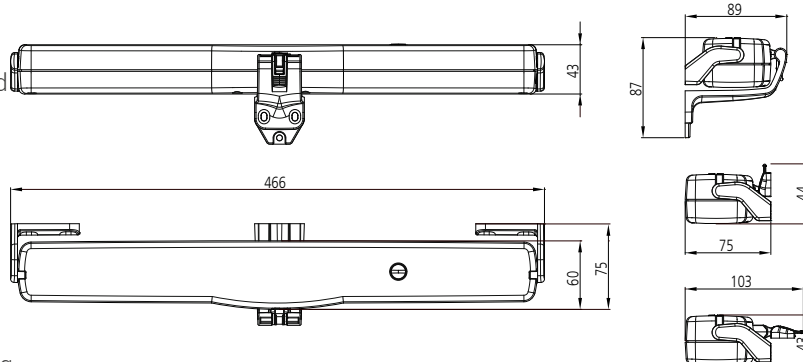





without any need for screws (patented). Electronic stroke-end for opening with three strokes (200 - 300 - 500 mm), which can be selected at any time using dip-switches; stroke-end upon power absorption during closing and as protection against overloading. The actuator is equipped with a Soft-Stop and Relax function, and it can be connected in parallel. Complies with the Directives 2004/108 EC (EMC Directive) and 2006/95 EC (Low Voltage Directive). Standard colours: Black (RAL9005) with a black cable, White (RAL9010) and Grey (RAL9006) with white cables. The 24 V CC versions have a black silicone cable. Additional characteristics are provided in the technical data table.

Model	Varia Slim Plus 24 V Code 07880	Varia Slim Plus Syncro 24 V Code 07881	Varia Slim Plus 230 V Code 07882	Varia Slim Plus Syncro 230 V Code 07883
Push and pull force	300 N			
Strokes	200/300/500 mm			
Synchronisation	NO	YES	NO	YES
Power-supply voltage	24 V CC		110 ÷ 230 V CA 50/60 Hz	
Current absorbed at nominal load	0,910 A		0,160 A	
Power absorbed at nominal load	~ 20 W		~ 36 W	
No-load speed	8,9 mm/s		7,2 mm/s	
Maximum no-load stroke time	56 s		70 s	
Double electrical insulation	Low voltage		Yes	
Service type	S2 di 3 minuti			
Operating temperature	-5 ÷ 65 °C			
Degree of protection for electrical devices	IP32			
Soft Stop	Sì			
Relax function	Sì			
Self-learning frame rebated overlap	Self-determination of the position			
Connection in parallel	YES (max 30 actuators)			
Power-supply cable length	2 m	2,5 m	2 m	2,5 m
Opening stroke-end setting	Electronic dip-switch setting			
Closing stroke-end setting	Upon absorption of power			
Protection on overload at opening and closure	Upon absorption of power			
Dimensions	456 x 60 x 43 mm			
Weight	1,63 kg		1,43 kg	
Static holding force	1700 N			
Supplied brackets	Only frame brackets included. Sash bracket to be ordered separately.			
Connection with Slim Lock	YES	YES	NO	NO

I dati riportati in queste illustrazioni non sono vincolanti e possono essere soggetti a variazioni anche senza preavviso.

Varia Slim Plus & Slim Plus Syncro - Accessories

	Code	Description	Model
	05900	Bottom-hung-window bracket (to be ordered separately)	OUTWARD-OPENING WINDOW BRACKET - VARIA SLIM PLUS
	05901	Outward-opening bracket (to be ordered separately)	Top-hung bracket - Varia Slim Plus
	05902	Top-hung bracket (to be ordered separately)	Top-hung bracket Varia Slim Plus
	05909	Top-hung bracket (to be ordered separately)	Top-hung bracket Varia Slim Plus - 15 mm
	05911	Special frame support brackets for Varia Slim Plus, Varia Slim, and Varia Slim Base (to be ordered separately)	Metal support brackets H 45 mm (cp)
	05903	Standard frame support brackets (spare part)	Standard support brackets Varia Slim Plus (cp)
	05908	Quick connector for VARIA SLIM PLUS, VARIA SLIM and VARIA SLIM BASE (spare part)	Quick connector

VARIA SLIM

Chain actuator 300N

Varia Slim is a perfect combination of performance, quality, and safety. The unit is available in a 230 V CA mains version and in a low-voltage 24 V CC version. The Varia Slim frame is made of extremely robust technopolymer.

Sash and frame brackets included (bottom-hung, top-hung).

Four different chain strokes are available: 110, 200, 300 and 400.



Natural
ventilation



Go to the technical data sheet



Fibreglass-reinforced polyamide actuator housing and sash and frame fixing brackets.



Sash and frame brackets supplied with the product.



The actuator chain disconnects easily and quickly from the sash bracket.



Choice of 4 different chain strokes by means of dip-switches.



Relax function for resting mechanical parts after every stroke-end.



Code	Description
07884	VARIA SLIM 230 V
07885	VARIA SLIM 24 V

● 590 - Black ○ 560 - White ● 542 - Grey

VARIA SLIM SYNCRO

300N synchronised actuator

Varia Slim Syncro boasts all the main technical features of Varia Slim but it also gives the option of perfectly synchronised operation with another Varia Slim Syncro.

Varia Slim Syncro is the ultimate choice for large windows requiring 2 or more thrust and pull points. With Varia Slim Syncro you can synchronise up to 8 actuators simultaneously without any need for an external controller. The product comprises a pair of actuators preset to operate in sync.

Three different chain strokes are available: 100, 200 and 400.

Note: Syncro items are made up of two actuators (one couple).



Go to the technical data sheet



Fibreglass-reinforced polyamide actuator housing and sash and frame fixing brackets.



Sash and frame brackets supplied with the product



Actuator chain disconnects easily and quickly from the sash bracket



Choice of 3 different chain strokes by means of dip-switches.



Relax function for resting mechanical parts after every stroke-end.



Synchronisation of up to 8 actuators without any need for an external controller.



Code	Description
07886	VARIA SLIM SYNCRO 230 V
07887	VARIA SLIM SYNCRO 24 V

● 590 - Black ○ 560 - White ● 542 - Grey

VARIA SLIM RADIO

Chain actuator 300N

Varia Slim Radio is an advanced wireless version belonging to the Varia Slim family. Its body looks identical, but it is more sophisticated in terms of intelligence.

Complete with a radio-frequency receiver built into the body of the actuator, it should be installed wherever remote-control functions are required by means of Radio Remote Control (not included, see page 22) with rolling-code technology.

In any case it can also be connected to a wire pulse control located near the window.

In conjunction with the rain detectors (items 07893000 and 07894000), it ensures automatic window closure by wire or radio signal in the event of rain without the need for any additional control units.



Natural
ventilation



Go to the technical data sheet

Code	Description
07888	VARIA SLIM RADIO 230 V
07894	SENSORE PIOGGIA RI-SCALDATO - SPR CAVO
07892	RADIOCOMANDO - RC

Remote controls and rain sensors are supplied separately. See pages 22 and 23

● 590 - **Black** ○ 560 - **White** ● 542 - **Grey**

Varia Slim, Slim Syncro e Slim Radio - Technical data

Specifications

Linear electric actuator: with double-row four-link articulated chain enclosed in an appropriate high-strength composite casing (glass fibre reinforced polyamide) and suitable for moving awning windows, hopper windows, dormer windows and light domes.

The actuator has a push and pull force of 300N and is designed to function both at a voltage of 230 V AC 50 Hz or at a lower voltage of 24 V DC.

The actuator comes supplied with quick-coupling screwless assembly brackets (patented) and awning and bottom-hung-window brackets with quick coupling/uncoupling of the window (patented). Stroke-end: electronic opening stroke-end with variable strokes that can be selected at any time using dip-switches. Closing stroke-end upon power absorption. Can be connected in parallel. Complies with Directives 2004/108 EC (EMC Directive) and 2006/95 EC (Low Voltage Directive). Standard colours: Black with black cable, White and Grey with white cables.

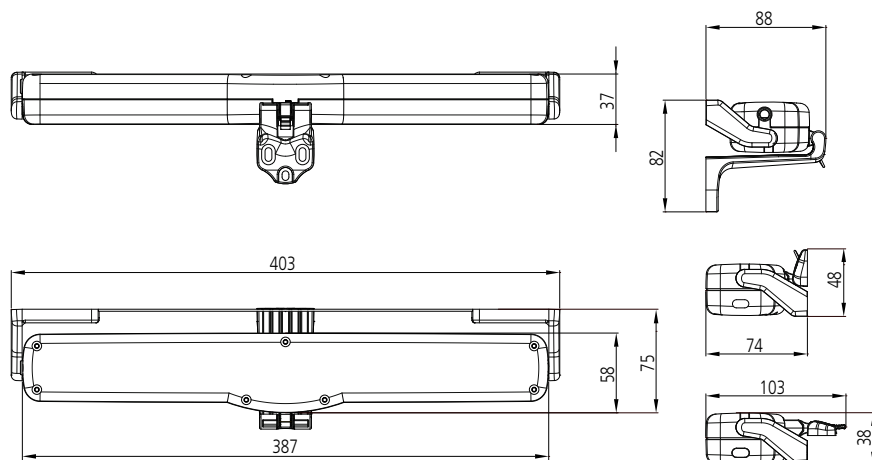

Model	Varia Slim 230 V Code 07884	Varia Slim 24 V Code 07885	Varia Slim Syncro 230 V Code 07886	Varia Slim Syncro 24 V Code 07887	Varia Slim Radio 230 V Code 07888
Push and pull force	300 N				
Strokes	110/200/300/400 mm		100/200/400 mm		100/200/300/400 mm
Synchronisation	NO	NO	YES	YES	NO
Power-supply voltage	230 V ~ 50 Hz	24 V =	230 V ~ 50 Hz	24 V =	230 V ~ 50 Hz
Current at nominal load	0,115 A	0,950 A	0,115 A	0,950 A	0,160 A
Power absorbed at nominal load	~ 25 W	~ 23 W	~ 25 W	~ 25W	~ 28 W
No-load speed	12,5 mm/s		8,5 mm/s		12 mm/s
Maximum no-load stroke time	32 s	32 s	48 s	48 s	30 s
Double electrical insulation	YES	L.V.	YES	L.V.	YES
Service type	S2 di 3 min				
Operating temperature	-5 °C ÷ +65 °C				
Degree of protection for electrical devices	IP30				
Soft Stop	NO	NO	YES	YES	NO
Relax function	YES	YES	YES	YES	YES
Self-learning frame rebated overlap	Self-determination of the position				
Connection in parallel	YES	YES	YES	YES	NO
Power-supply-cable length	2 m	2 m	2,5 m	2,5 m	2 m
Opening stroke-end setting	Dip-switch setting				
Closing stroke-end setting	Upon absorption of power				
Overload protection	Upon absorption of power				
Dimensions	387 x 59 x 37 mm				
Weight	0,97 kg	0,94 kg	1,18 kg	1,15 kg	1,17 kg
Static holding force	1700 N				
Supplied brackets	Sash and frame brackets for top/bottom hung and sill application				
Connection with Slim Lock	NO	YES	NO	YES	NO

The data provided in these illustrations is non-binding and subject to change, even without advance notice.

REMOTE-CONTROL

For radio-operated remote-control operation.

The transmitter is modern, functional, comfortable and ergonomic.

30 direct transmission channels (with the F1 and F2 functions, 90 control outputs can be reached) via radio waves at a frequency of 433.92 MHz rolling code with a resolution higher than 18×10^{18} possible combinations.



Code	Model	For actuator
07892	RADIO COMAN-DO - RC	VARIA SLIM RADIO



Go to the technical data sheet

Radicomando - Technical data

Model	Radicomando - Rc Code 07892
Type	Multi-channel-radio remote control with microprocessor
Number of transmission channels	30
Transmission frequency	433.92 MHz
Modulation	ASK
Power-supply voltage	2 x 1.5 V batteries – type AAA
Operating voltage	1.8 V ÷ 3.3 V
Estimated battery lifespan	> 2 years (based on an average use of 1 minute per day)
Display	LCD (liquid-crystal display)
Visualisation	2 digits (selected channel)
	battery-charge-status indicator
	transmission state
	Specific functions letters
Display dimensions	18.5 x 13.5 mm
Encoding	HCS301
Independent codes	> 18×10^{18} "rolling-code" combinations
Absorption in stand-by mode	< 1 µA
Absorption during transmission	< 20 mA
Keypad	Operational control (UP arrow, DOWN arrow, STOP)
	2 Function buttons (F1, F2)
	1 Memory button (M)
	1 Channel button (CH)
Transmission distance	50 m (with charged batteries)
Regulatory references	Approved in compliance with the R&TTE Directive 1999/5/EC – Directive 1999/5/EC of the European Parliament and Council of 9 March 1999
Dimensions	145 x 38.5 x 22.5 mm
Weight	76 g

The data provided in these illustrations is non-binding and subject to change, even without advance notice

RAIN DETECTOR heated

The rain-detector device should be placed outside so it can interact with the actuators in the event of incessant rain. The sensor can be connected:

directly by wire to Varia Slim Radio – SPR CABLE

directly by radio signal to Varia Slim Radio – SPR RADIO

The sensor is not sensitive to dewdrops or humidity, it dries quickly after rainfall and is not susceptible to ice formation. 5 metres in length, the power-supply cable has been built to withstand harsh environments and inclement weather, featuring a highly weather-resistant PVC sheath which is also non-fire-propagating and resistant to UV radiation.



Code	Model	For actuator
07894	HEATED RAIN SENSOR SPR CABLE	VARIA SLIM RADIO 07888



Go to the technical data sheet

Heated rain sensor - Technical data

Model	Heated rain sensor SPR cable Code 07894
Power-supply voltage	12 V ÷ 24 V = (CC)
Maximum absorption power	20 mA – (120 mA with active heater)
Type of sensor	Capacitive
Heater intervention	< +4 °C
Contact type	SPDT
Contact rating	0,5 A/125 V CA – 1 A/24 V CC
Radio-transmission frequency	-
Operating temperature	-20 ÷ +65 °C
Feeding cable length	5 m
Feeding cable type - wire number	PVC LiY2Y protected from UV - 5 wires
Degree of protection for electrical devices	IP65
Dimensions	45 x 93 H = 19 mm
Weight	552 g (cable excluded)

The data provided in these illustrations is non-binding and subject to change, even without advance notice

SLIM LOCK Electric lock

Slim Lock is an electric lock specially designed to automatically open/close the multi-point-locking system on top-hung, bottom-hung and parallel windows in conjunction with Varia Slim 24 V chain actuators. The presence of locking points around the window significantly increases its air, water and wind tightness.

Slim Lock is small and unobtrusive (25 × 26 mm) with recessed installation inside a slot in the window frame and no impact on visual design.

Slim Lock operates quietly and comes equipped with advanced electronics.

It works in conjunction with Varia Slim 24 V actuators: upon the opening signal, the lock releases the locking points before the actuator goes into action; conversely it blocks the locking points as soon as the window is closed. The push/pull force (600 N – 850 N at start) ensures high operational reliability even when the locking points are numerous.

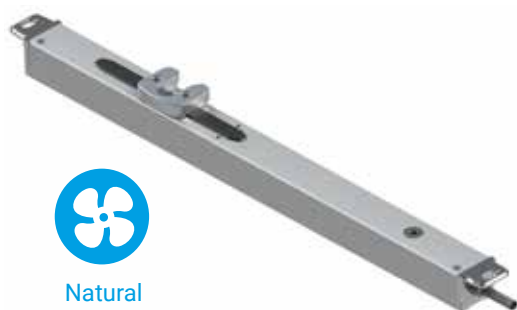

Natural ventilation



Quiet and powerful

TESTED
10,000

Reliability tested via 10,000 cycles at maximum load



Syncro technology (patented) allows for up to 8 Slim Lock and Varia Tube 24 V actuators to be connected together



Go to the technical data sheet

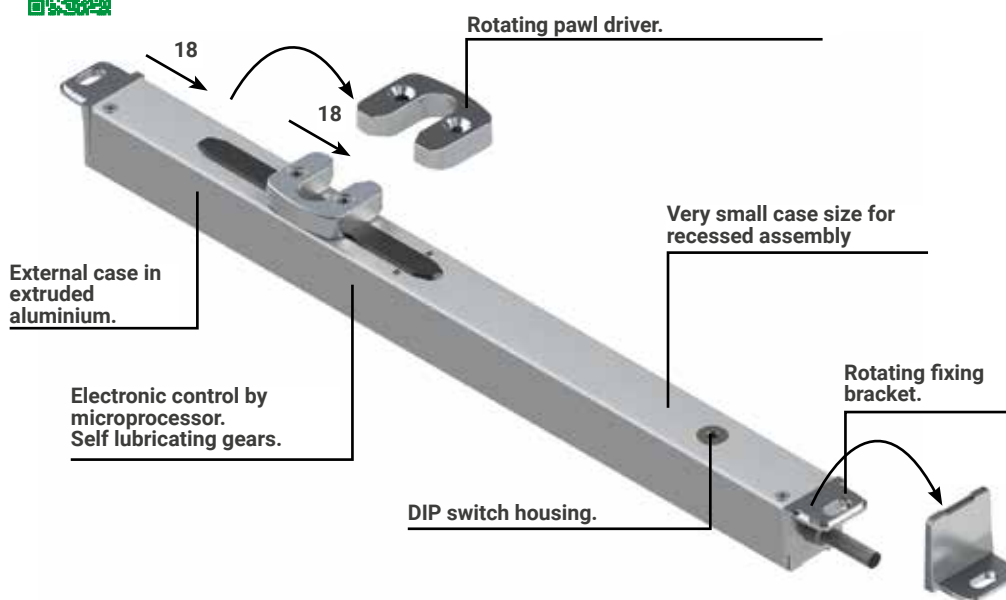

Code	Description
------	-------------

07895	SLIM LOCK 24 V
-------	----------------

● 000 - Anodised silver

Slim Lock - Technical data

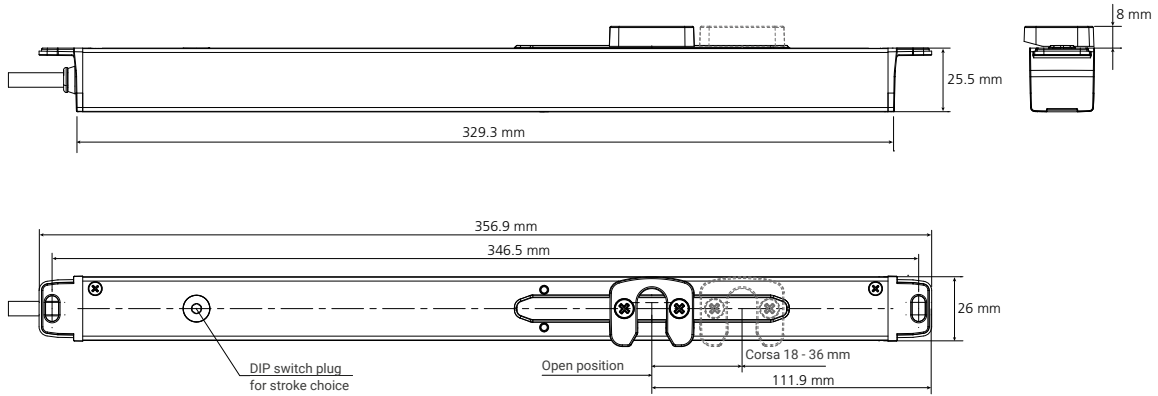

Model	Slim Lock 24 V CC Code 07895
Push and pull force	600 N – 850 N at start
Stroke	18 mm/36 mm
Power-supply voltage	24 V CC
Current absorbed at nominal load	0.85 A during the opening/closing - 1.2 A for amperometric block
Power absorbed at nominal load	~ 20 W
No-load speed	5 mm/s
Maximum no-load stroke duration	4 s (18 mm) – 7,2 s (36 mm)
Double electrical insulation	Very low tension
Duty rate	30%
Service	S2 - 1 minute
Case material	Very low tension
Operating temperature	-20 °C ÷ +70 °C
Degree of protection for electrical devices	IP40
Opening/closing stroke-end setting	Electronically set
Operating with chain actuators	Selectable
Operating without chain actuators	Selectable
Silicone cable	3 x 0,5 mm ² - 2,00 m
Overload protection during opening/closing phases	Supply cut due to power overload
Dimensions	25,5 x 25,5 x 357 mm
Slot required	27 x 335,5 mm
Weight	0,560 kg
Matching actuators	Varia Slim Small 24 V art. 07891 Varia Slim Plus 24 V art. 07880 – Varia Slim Plus Syncro art. 07881 Varia Slim 24 V art. 07885 – Varia Slim Syncro art. 07887 (NO Varia Slim Base 24 V – art. 07890)

The data provided in these illustrations is non-binding and subject to change, even without advance notice.

VARIA SLIM BASE Chain actuator 250N

Chain actuator for awning windows, hopper windows, dormer windows and light domes. Simple mechanical selection of the two strokes, 240 mm and 360 mm. Equipped with a microprocessor with relax function and power control over the entire stroke.



Natural
ventilation



Progressive starting ramp



Power control over the entire stroke



Body and brackets are made from a high-strength composite material (glass-fibre reinforced polyamide)



Even simpler and more intuitive stroke selection



Relax function for resting mechanical parts after every stroke-end



Go to the technical data sheet

Code	Description
07889	VARIA SLIM BASE 230 V
07890	VARIA SLIM BASE 24 V

● 590 - Black ○ 560 - White ● 542 - Grey

Varia Slim Base - Technical data

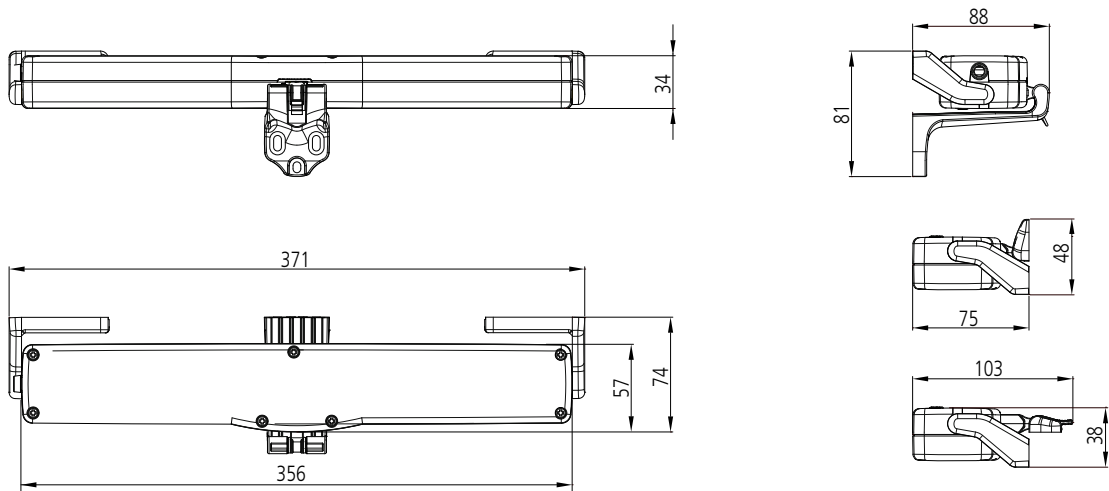

Specifications

Linear electric actuator with double-row four-link articulated chain enclosed in composite casing suitable for moving awning windows, hopper windows, dormer windows and light domes. The actuator has a push and pull force of 250 N and is designed to function at 110/230 V AC 50/60 Hz or 24 V DC. It comes supplied with quick-coupling screwless assembly brackets (patented), awning and bottom-hung-window brackets with quick coupling (patented).

Two opening strokes with mechanical selection. Stroke-end stop during opening and closing upon power absorption and as protection against overloading. Can be connected in parallel.

Complies with Directives 2004/108 EC (EMC Directive) and 2006/95 EC (Low Voltage Directive).

Standard colours: Black with black power cable, White and Grey with white cables.

Model	Varia Slim Base 230 V Code 07889	Varia Slim Base 24 V Code 07890
Push and pull force	250 N	
Strokes	240/360 mm	
Synchronisation	NO	
Power-supply voltage	110 ÷ 230 V ~ (CA) 50/60 Hz	24 V = (CC)
Current at nominal load	0,180 A	0,800 A
Power absorbed at nominal load	~ 30 W	~ 18 W
No-load speed	13,5 mm/s	12,8 mm/s
Maximum no-load stroke time	18 s/27 s	19 s/28 s
Double electrical insulation	SI	Low Voltage
Service type	S2 di 3 min	
Operating temperature	-5 °C ÷ +65 °C	
Degree of protection for electrical devices	IP30	
Soft Stop	NO	
Relax function	YES	
Self-learning frame rebated overlap	Upon absorption of power	
Connection in parallel	YES	
Power-supply-cable length	1 m	2 m
Opening stroke-end setting	Upon absorption of power	
Closing stroke-end setting	Upon absorption of power	
Overload protection	Upon absorption of power	
Dimensions	356 x 57 x 34 mm	
Weight	0,84 kg	0,82 kg
Static holding force	1700 N	
Supplied brackets	Sash and frame brackets for top/bottom-hung application	
Collegamento con Slim Lock	NO	NO

The data provided in these illustrations is non-binding and subject to change, even without advance notice.

Varia Slim & Slim Base - Accessories and Spare parts

	Code	Description	Model
	05910	Top-Hung bracket for VARIA SLIM and VARIA SLIM BASE	Outward opening bracket - Security clutch H 14,5 mm
	05904	Standard support brackets (cp) for VARIA SLIM and VARIA SLIM BASE	Standard support brackets (cp)
	05905	Brackets for vertical mounting for VARIA SLIM e VARIA SLIM BASE	Brackets for vertical mounting (cp)
	05906	Brackets for outward opening for VARIA SLIM and VARIA SLIM BASE	Outward-opening bracket
	05907	Bottom-hung-window brackets for VARIA SLIM and VARIA SLIM BASE	Outward-opening window bracket
	05908	Quick connector for VARIA SLIM PLUS, VARIA SLIM and VARIA SLIM BASE	Quick connector

● 590 - **Black** ○ 560 - **White** ● 542 - **Grey**



VARIA SLIM SMALL Chain Actuator 200 N

With a compact design and sleek silhouette, VARIA SLIM SMALL can be incorporated into curtain-wall cross-beams and does not only contribute to the beauty of an uninterrupted glazed surface, it also provides a perfect solution for conventional openings.

Varia Slim Small can be applied to awning windows, hopper windows, dormer windows and light domes. Intelligent, compact and robust (made entirely of metal), it is the smallest actuator for windows available on the market. With recessed mounting on any European chamber profile, it fixes onto the frame with two brackets.

Remarkably quiet (only 42 db) and sturdy, it boasts a compact design and measures only 28 x 28 x 310 mm.



Progressive starting ramp



Power control over the entire stroke



Intuitive and immediate stroke selection with a dip-switch



Relax function for resting mechanical parts after every stroke-end



Embedded window brackets allowing for motor inspection, even during a power outage or in the event of product failure



Natural ventilation



Go to the technical data sheet



Code	Description
07891	VARIA SLIM SMALL 24 V

● 970 - RAL 9006

Varia Slim Small - Technical data

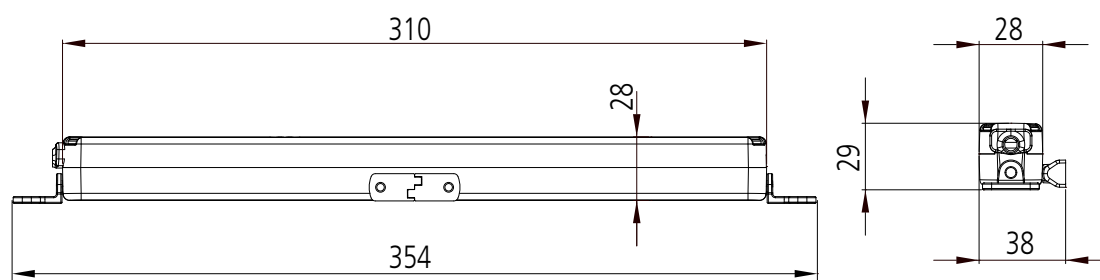

Specifications

Linear electric actuator with three-link articulated chain (patented) enclosed in an appropriate metal casing and suitable for moving awning and hopper windows. The actuator has a push and pull force of 200 N and only functions only at a low voltage (24 V CC).

It comes supplied with pivoting support brackets, no screws and universal coupling brackets for awning and hopper windows. Opening stroke-end can be adjusted at any time by selecting the appropriate dip-switches whilst closing stroke-end occurs upon power absorption and as a protection mechanism against overload.

Can be connected in parallel.
Complies with Directives 2004/108 EC (EMC Directive) and 2006/95 EC (Low Voltage Directive).

Colours available: Grey (RAL9006) with black-silicone cable.

Model	Varia Slim Small 24 V Code 07891
Push and pull force	200 N
Strokes	70/125/170/210 mm
Synchronisation	NO
Power-supply voltage	24 V = (CC)
Current absorbed at nominal load	0,32 A
Power absorbed at nominal load	7,5 W
No-load speed	6 mm/s
Maximum no-load stroke time	27 s
Double electrical insulation	Low Voltage
Service type	S2 of 3 min
Operating temperature	-5 °C ÷ +65 °C
Degree of protection for electrical devices	IP32
Soft Stop	NO
Relax function	YES
Self-learning frame rebated overlap	Upon absorption of power
Connection in parallel	YES
Power-supply-cable length	2 m
Opening stroke-end setting	Dip-switch setting
Closing stroke-end setting	Upon absorption of power
Overload protection	Upon absorption of power
Dimensions	28 x 28 x 310 mm
Weight	0,72 kg
Static holding force	1000 N
Supplied brackets	Standard support brackets, sash brackets
Connection with Slim Lock	YES

I dati riportati in queste illustrazioni non sono vincolanti e possono essere soggetti a variazioni anche senza preavviso.

VARIA E VARIA UNI Chain actuator IN 300 N - OUT 150 N

Rugged durable chain actuators for bottom-hung and top-hung windows. Chain stroke adjustable from 90 to 400 mm for Varia by means of a selector.

Thrust force = 150 N

Pulling force = 300 N

Equipped with a limit switch and indicator light which warns that the window is closing, this unit can be easily connected to the power line with the pull-put terminal board.

The drive chain is protected with a thin non-electrolytic "Geomet" coating to impart optimal corrosion resistance.

The actuator is supplied with a frame-fixing bracket, 2 sash brackets (one top-hung and one bottom-hung), all the required fixing screws and a positioning template.

Comes supplied with fittings, drilling templates and brackets for top-hung and bottom-hung windows. An extended chain pin is also available on request for wood and PVC frames.



Ventilazione
naturale



Go to the technical data sheet



Code	Description
01654	VARIA UNI 230 V
01495	VARIA 24 V

● 010 - Black ○ 560 - White ● 544 - Grey ● 593 - Brown

Varia e Varia Uni - Technical data

Specifications

Electric actuator with articulated chain housed in a case made of high-strength composite material (fibreglass reinforced polyamide) suitable for the automation of top-hung and bottom-hung windows. Geomet-treated chain for enhanced corrosion resistance.

Pulling force 300 N and thrust force 150 N (or 200 N). 230 V AC 50/60 Hz or 24 V DC power supply. Comes supplied with brackets and fixing screws for rapid reliable product installation.

Provided with micro limit switch. Can be connected in parallel. Adjustment of the chain stroke from 90 mm to 400 mm by means of a mechanical selector with 12 mm adjustment steps.

Standard colours: black, white, grey, and brown. Additional characteristics are provided in the technical data table.

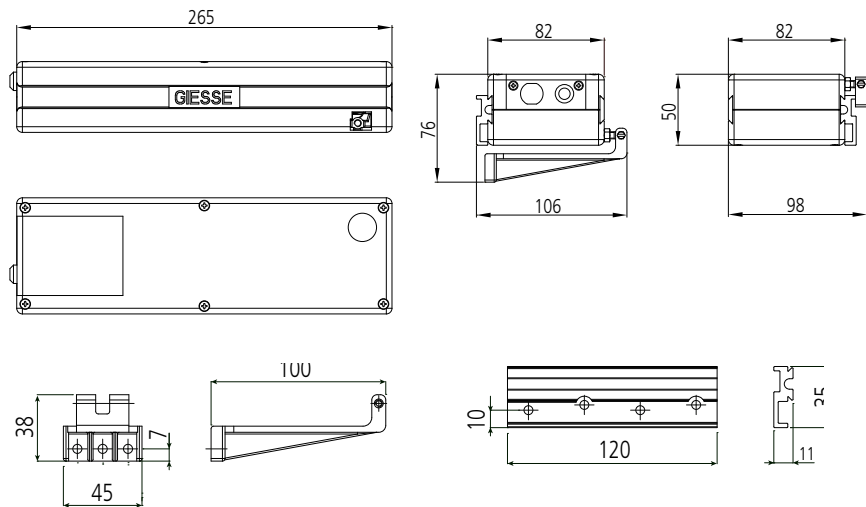

Model	Varia UNI 230 V Code 01654	Varia 24 V Code 01495
Power-supply voltage	230 V CA 50/60 Hz	24 V CC
Thrust force	150 N	
Drive force	300 N	
Strokes adjustable every 12 mm	from 90 to 400 mm	
No-load speed	40 mm/s	
Front adjustment	max. 10 mm	
Parallel connection	YES (max. 4) 230 V	
Power absorbed at nominal load	170 W	40 W
Current absorbed at nominal load	0,8 A	1,8 A
Thermal protection	120 °C	
Capacitor	4 µF	
Relay included	YES	
Lamp indicating limit switch	YES	
Removable terminal block	YES	
Degree of protection for electrical devices	IP20	
Operating temperature	- 20 °C / + 40 °C	
Supplied brackets	Standard support bracket (frame), sash brackets (bottom hung, top hung opening)	

Varia 24 V e Varia Uni 230 V - Accessories and Spare parts

	Code	Description	Model
	63993 04847	Extension pins for Varia chain for wooden and PVC windows	Extended pin for chain - 40 mm (for steps 13 ÷ 21 mm) Extended pin for chain - 50 mm (for steps 22÷ 33 mm)
	01662	L-shaped bracket for fitting on the windowsill of Top-Hung windows.	L-shaped bracket for fitting on the windowsill
	0479301	Test kit for the adjustment of the chain length exiting Varia UNI actuator during the operating test on the bench.	Pul Varia (230 v)
	04796 04797	Fast fixing kits for "Euro Groove" and "R" profiles for a significant reduction in assembly time.	Rapid bracket kit for bottom-hung window (Euro groove) Rapid bracket kit for bottom-hung window (R40-R50-R50tt)
	04794	Fast fixing kits	Universal fixing kit for top-hung windows
	04795	Spare parts	Universal fixing kit for top-hung windows

● 190 - Black ○ 000 - Raw



BOTTOM-HUNG MULTIPOINT KIT

AUTOMATION WITH MULTILOCKING

The bottom-hung window multi-point kit uses Varia or Varia Slim actuators' chain movement to activate a mechanism that turns transverse motion into axial motion. The resulting push allows to move the entire locking system (on 3 sides of the window) via a special pawl mounted on the window's rod. The mechanism movement is unidirectional (standing in front of the window: locking on the left side and opening on the right side).

The bottom-hung-window multi-point allows for perimeter fastening on 3 sides using standard Giesse pawls and strikers. This feature greatly increases the air-, water- and wind tightness of the automated bottom-hung window.



Natural
ventilation



Go to the technical data sheet

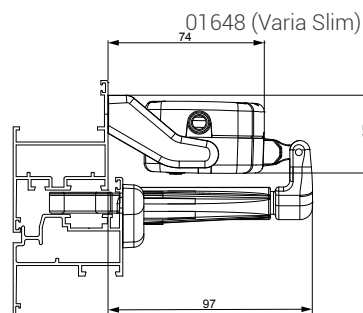
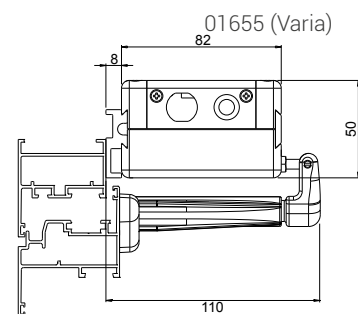
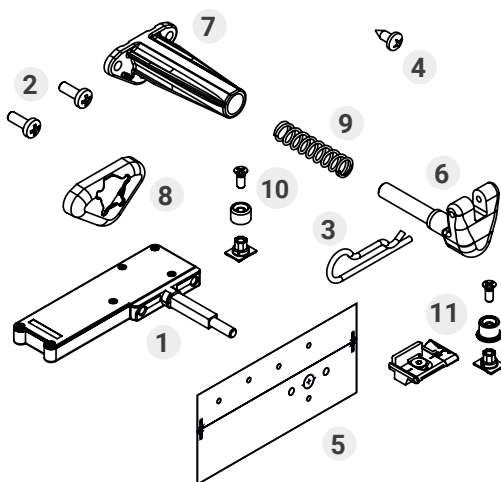

1. Multi-locking mechanism (x1)
2. Screws M 5x14 (x2)
3. Fixing spring (x1)
4. 4.8x13 screw (x1)
5. Sash drilling template (x1)
6. Front bracket for chain connection (x1)
7. Bracket carter (x1)
8. Carter screw cover (x1)
9. Spring (x1)
10. Driving pawl (x1)
11. Locking point (x1)

Code	Description	Code	Description
01648	VARIA SLIM MULTI-LOCKING ACCESSORY KIT	01664	ADAPTER FOR R40 SYSTEM
01655	VARIA SLIM MULTI-LOCKING ACCESSORY KIT		R40 systems need to be completed by adding two 01664000.

Bottom-hung multipoint kit - Technical data

Specifications

Mechanism made up of a system of levers operated by a pin inserted inside the front-fixing bracket of the chain that pulls the rod with a one-way movement, using the movement of the chain itself.

Activating the actuator in the opening direction first causes the pin and levers to move and this in turn leads to the movement of the rod and release of the fastening mechanisms, meaning the window can be opened.

Activating the actuator in the closing direction produces the opposite effect: the returning chain closes the sash and then continues its action, compressing the pin and consequently securing the fastening mechanisms.

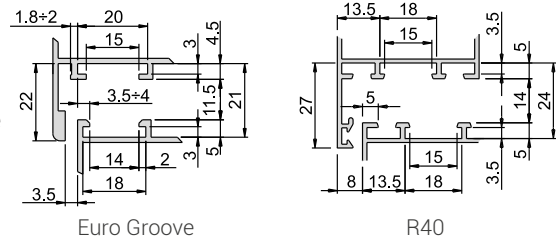

Euro Groove

R40

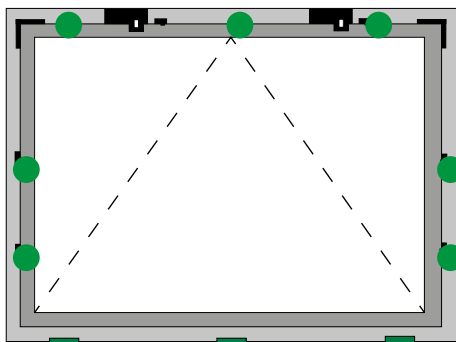
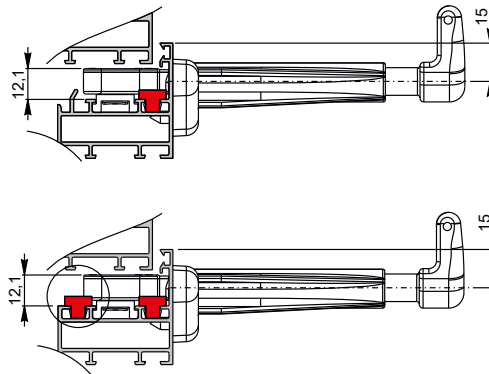
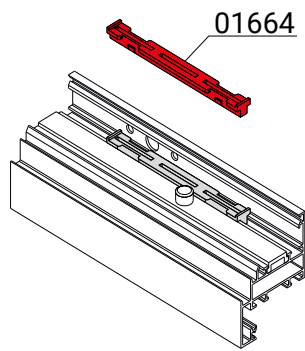

MAX.
130 KG

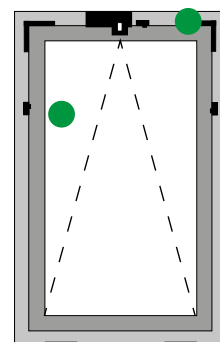

MAX.
70 KG

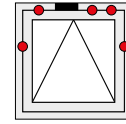
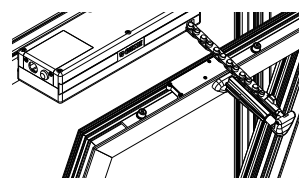
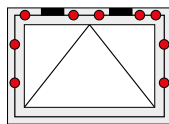
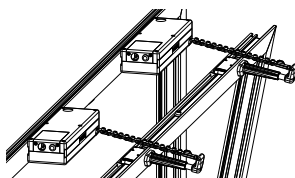

ROD ACTUATOR ST450

Electro-mechanical actuator with rigid rod mechanism

The linear rod actuator is particularly suitable for moving windows and doors that require a high degree of reliability and resistance to a combination of bending and compressive stresses. Ideal for skylights and shed windows, top-hung windows, vertical sunblinds, and jalousie windows.

They stand out in terms of speed and silence as well as their extreme versatility in terms of application.



Natural ventilation



Fast and silent



Can be installed everywhere



Attractive design



Takes up little space



Go to the technical data sheet



Code	Description
0479101	ST450 stroke 180 (top hung)
0479201	ST450 stroke 300 (top hung)
0156001	ST450 stroke 180 (vertical sunblinds)

● 020 - Anodised silver

Rod actuator - Technical data

Specifications

Electric actuator with aluminium enclosure, linear movement and rigid rod. Operation at 230 V AC, fitted with micro limit switch and thermally protected. Can be connected in parallel using the relay incorporated in the card. Equipped with a 1.5-m-long connection cable already wired inside the actuator.

The presence of two continuous lateral guides facilitates the positioning of the fixing bracket at any point along the motor housing, making it easier to adjust the window-locking position. Supplied with brackets and supports for the requested application.

The electric actuator has a push and pull force of 450N and it is available in the versions for top-hung windows or for vertical sunblinds and jalousie windows.

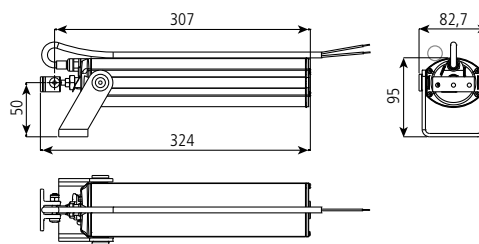
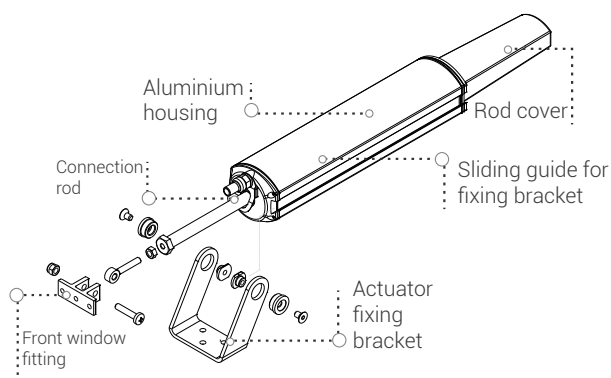

0479101 ST450 stroke 180 - for TOP-HUNG windows

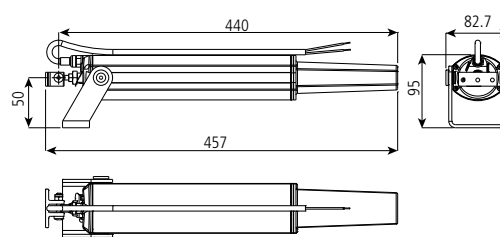

04792 ST450 stroke 300 - for TOP-HUNG windows

Model

ST450

	TOP HUNG		VERTICAL SUNBLINDS
	0479101	0479201	0156001
Code	0479101	0479201	0156001
Corse	180 mm	300 mm	180 mm
Tensione di alimentazione	230 V c.a. ± 5%		
Push and pull force	450 N		
Max idle stroke duration	7	12	7
Noload speed	23 mm/s		
Current absorbed at nominal load	0,7 A		
Power absorbed at nominal load	150 W		
Thermal protection	SI		
Capacitor	5 µF		
Limit switch	SI		
Relay included	SI		
Pre-wired power-supply cable	SI		
Can be connected in parallel	1500 mm		
Degree of protection for electrical devices	IP55		
Operating temperature	20/+70 °C		
Sash and frame brackets	Included		

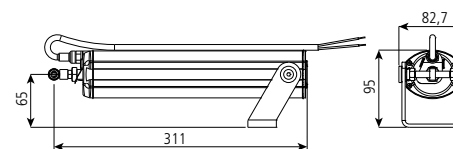
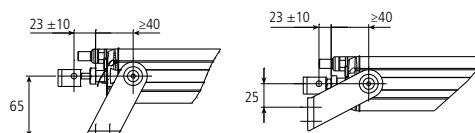
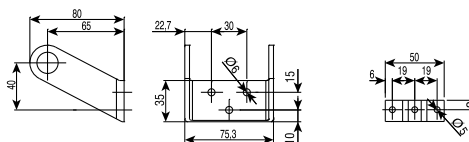

01560 ST450 stroke 300 - for VERTICAL SUNBLINDS

RACKMAX 450

Electric rack actuator

- Rackmax 450 is the electric actuator with linear rack movement and a thrust and pull force of 450 N.
- 110-230 V~ 50/60 Hz supply voltage.
- Available in different stroke lengths: 180, 230, 350, 550, 750 and 1,000 mm
- Sash bracket and frame in polyamide (supplied)
- Large sash-bracket adjustment range over the entire length of the rod
- Opening and closing load-dependent stroke limit as electronic overload protection
- Can be connected in parallel.
- Complies with the 2004/108 EC (EMC) directive



Natural
ventilation

450N
↔

Thrust and pull force 450 N



Can be connected in parallel



Available in a 110-230 V AC version



Go to the technical data sheet

Code	Description
07432	RackMax 450 230 V - 180 mm
07433	RackMax 450 230 V - 230 mm
07434	RackMax 450 230 V - 350 mm
07435	RackMax 450 230 V - 550 mm
07436	RackMax 450 230 V - 750 mm
07437	RackMax 450 230 V - 1000 mm

● 000 - Anodised silver

Rackmax 450 - Technical data

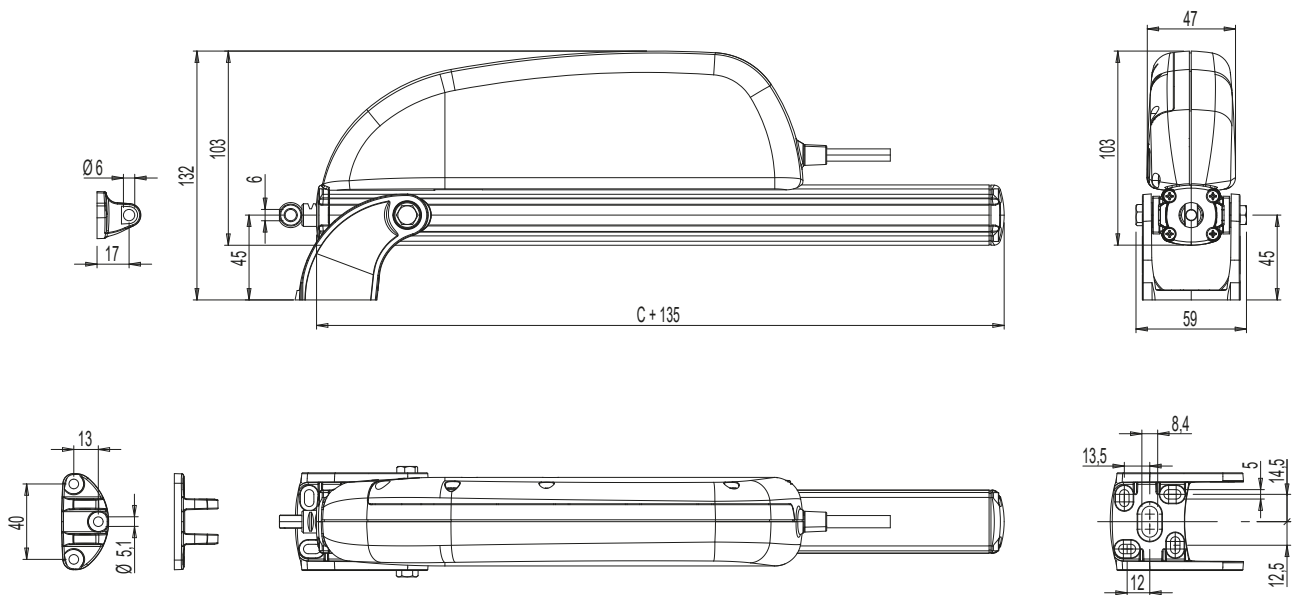

Model	230 V CA
Thrust and drive force (F_N)	450 N
Strokes (Sv)	180, 230, 350, 550, 750, 1000 mm
Power-supply voltage (U_N)	110 - 230 V ~ 50/60 Hz
Current absorbed at nominal load (I_N)	0,28 - 0,19 A
Power absorbed at nominal load (P_N)	21,6 A - 24 W
Travel speed	6,7 mm/s
No-load stroke duration	Depends on stroke
Electrical insulation	Class II
Service type (DR)	2 cycles
Operating temperature	-5 +65 °C
Degree of protection for electrical devices	IP44
Self-learning frame rebated overlap	Position self-determination
Parallel connection	YES (max. 20)
Duo version (with Drive unit)	NO
Static holding force (depending on brackets)	2200 N
Closing stroke-end setting	Upon absorption of power
Overload protection	Upon absorption of power
Pre-wired power-supply cable	1 m
Dimensions	103 x 47 x (stroke + 135) mm
Weight	Variabile
Polyamide sash/frame brackets	Included

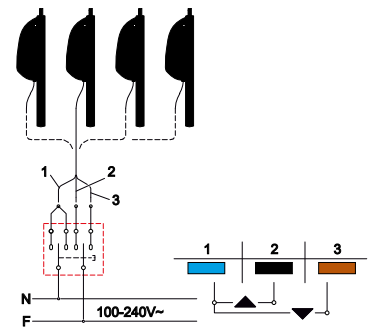

RACKMAX 650 Electric rack actuator

Rackmax 650 is the electric actuator with linear-rack movement and thrust and pull force of **650 N**. It is possible to achieve a thrust force up to 1100 N by connecting two Rackmax 650 motors together using a drive tube..

- Option of obtaining **several thrust points** using a **Rackmax drive unit** or in combination with a second Rackmax 650
- Version with **110-230 V~ 50/60 Hz** and **24 V CC supply voltage**
- Available in different stroke lengths: **180, 230, 350, 550, 750 and 1,000 mm**
- Option of reducing the maximum exit of the rack (stroke) for the actuator prior to installation
- Sash bracket and frame in zamak (supplied)
- Wide bracket adjustment range over entire rod length
- Opening and closing load-dependent stroke limit as electronic overload protection
- Compliant with Directives 2004/108 EC (EMC Directive) and 2006/95 EC (L.V. Directive).



Natural
ventilation

650N

Thrust and pull force up to 600 N
(one race actuator)

1100N

Thrust and pull force up to 1,000 N
(two race actuators)



Can be connected in parallel



Available in a 24 V CC
and 110 - 230 V CA



Drive units available



Go to the technical data sheet
RackMax 650 230 V



Go to the technical data sheet
RackMax 650 24 V

Code	Model	Code	Model
0743801	RackMax 650 230 V - 180 mm	0744501	Rackmax 650 24 V - 230 mm
0743901	RackMax 650 230 V - 230 mm	0744601	Rackmax 650 24 V - 350 mm
0744001	RackMax 650 230 V - 350 mm	0744701	Rackmax 650 24 V - 550 mm
0744101	RackMax 650 230 V - 550 mm	0744801	Rackmax 650 24 V - 750 mm
0744201	RackMax 650 230 V - 750 mm	0744901	Rackmax 650 24 V - 1000 mm
0744301	RackMax 650 230 V - 1000 mm		

000 - Anodised silver

Rackmax 650 - Technical data

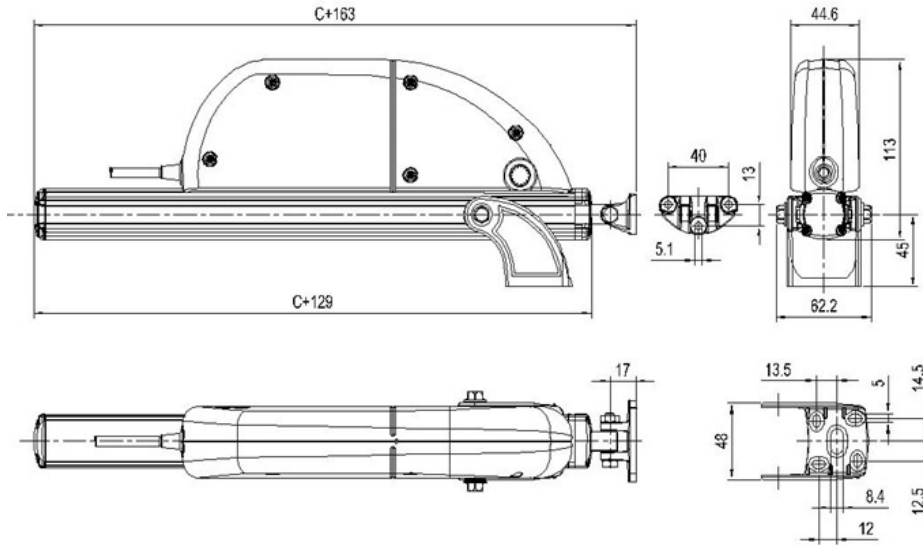

Modello	230 V CA	24 V CC
Thrust and drive force (FN)	650 N	
Strokes (Sv)	180, 230, 350, 550, 750, 1000 mm	
Power-supply voltage (UN)	110 - 230 V ~ 50/60 Hz	24 V =
Current absorbed at nominal load (IN)	0,37 - 0,18 A	1,0 A
Power absorbed at nominal load (PN)	28W - 24 W	24 W
Travel speed	5 mm/s	7 mm/s
No-load stroke duration	Depends on stroke	
Electrical insulation	Class II	Class III (Selv)
Service type (DR)	2 cicli	5 cicli
Operating temperature	-20 +70 °C	
Degree of protection for electrical devices	IP65	
Soft-stop	YES	
Relax function	YES	
Self-learning frame rebated overlap	Position self-determination	
Parallel connection	YES (max. 20)	
Synchronized operation	No	YES max 8
Duo version (with Drive unit)	YES	
Static holding force	3000 N	
Opening stroke-end setting	Electronic with encoder (after learning the limit stop)	
Closing stroke-end setting	Upon absorption of power	
Overload protection	Upon absorption of power	
Pre-wired power-supply cable	H05VV-F - 2m	
Noise detected	55 dB(A)	
Dimensions	44 x 113 x (stroke + 163) mm	
Weight	1,40 / 1,45 / 1,65 / 2,34 / 2,69 / 3,11 Kg	1,70 / 1,75 / 1,95 / 2,29 / 2,64 / 3,07 Kg
Synchronized function	NO	YES
Connection with electric lock Tube-Lock art. 07809	NO	YES

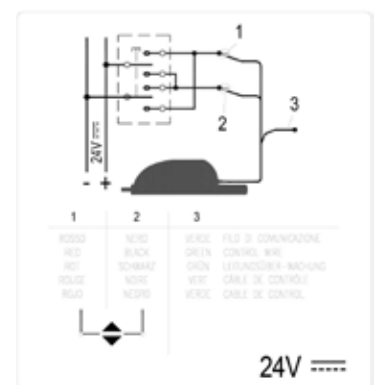
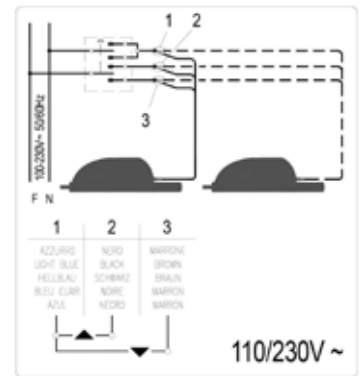

RACKMAX 650 Drive unit

The RACKMAX 650 drive unit combines with the RACKMAX 650 electric-rack actuator for the automation of top-hinged windows, shed windows, skylights, domes, jalousie windows and sunshade blades.

The Rackmax 650 drive unit can be applied in conjunction with one or two RackMax 650 rack actuators to gain more thrust points (see the table on the following page).

The physical connection between the drive motor (1) and the drive unit (3) takes place via an anodised aluminium drive tube (2), available for separate order and in different lengths - 1,000, 1,500, 2,000, 2,500 mm.

Rackmax 650 drive units are available in 180, 230, 350, 550, 750 and 1,000 stroke lengths and should be used in conjunction with compatible Rackmax 650 actuators.

Zamak sash and frame brackets are included.

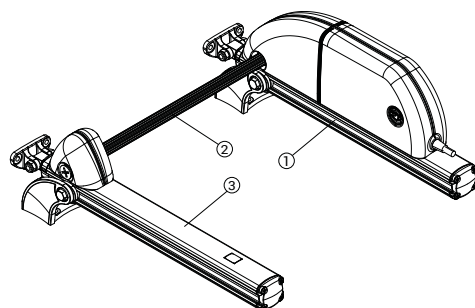

1. Chain actuator Rackmax 650
2. Drive tube
3. Drive unit



Go to the technical data sheet

Code	Model	Code	Model
0745001	Drive unit Rackmax 650 - 180 mm	0745301	Drive unit Rackmax 650 - 550 mm
0745101	Drive unit Rackmax 650 - 230 mm	0745401	Drive unit Rackmax 650 - 750 mm
0745201	Drive unit Rackmax 650 - 350 mm	0745501	Drive unit Rackmax 650 - 1,000 mm

● 000 - Anodised silver

RACKMAX 650 Drive tube

Drive tubes are employed to connect a Rackmax 650 rack actuator to one or more drive units, or to another Rackmax 650 motor.

The connection between the motor and the drive units takes place via an aluminium drive tube with fixing screws. The drive tube makes it possible to mechanically connect actuators and drive units (see table).

Drive tubes are available in the following lengths: 1,000, 1,500, 2,000, 2,500 mm.

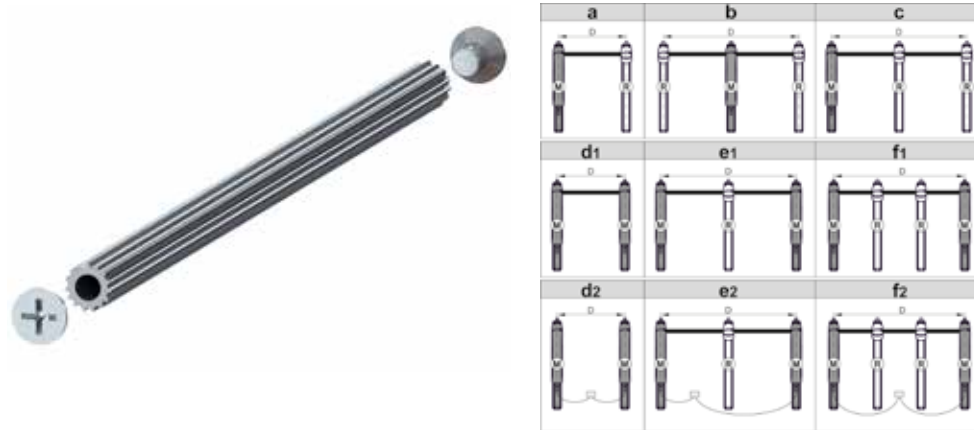

Configuration	Synchronization thrust points	N° engines (M)	N° drive units (R)	N° thrust points	Thrust force total
a 24V/230V	mechanical	1	1	2	650N
b 24V/230V	mechanical	1	2	3	650N
c 24V/230V	mechanical	1	2	3	650N
d1 24V/230V	mechanical	2	0	2	1100N
e1 24V/230V	mechanical	2	1	3	1100N
f1 24V/230V	mechanical	2	2	4	1100N
d2 24V	electronic	2	0	2	1100N
e2 24V	electronic	2	1	3	1100N
f2 24V	electronic	2	2	4	1100N



Go to the technical data sheet

Code	Model	Code	Model
07457	Drive tube - 1500 mm	07459	Drive tube - 2500 mm
07458	Drive tube - 2000 mm		

● 000 - Anodised silver

Rackmax 450 e Rackmax 650 - Accessories

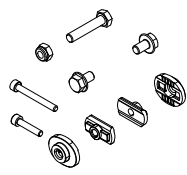
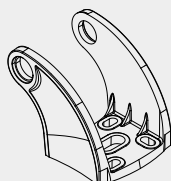
	Code	Description	Model
	07460	Fixing accessories	For RackMax 450, RackMax 650 and Drive unit
	07464	Zamak frame bracket	For RackMax 650 and Drive unit.

Chain actuator

Rod actuator

Rack actuators

Control Units



SHEV RWA CONTROL UNITS

for smoke and heat evacuation systems

SHEV control units are designed to be used in RWA systems for smoke and heat extraction. SHEV control units are installed together with Varia Tube RWA 24 V dc chain actuators as part of integrated systems that allow for the automatic and safe opening of windows in buildings in the event of fire. These systems are essential for the safety of building occupants because they allow smoke and heat to escape, protecting inhabitants from intoxication and facilitating the evacuation process.

The same RWA-system-controlled openings can be used for natural everyday room ventilation.



Smoke and heat
evacuation



Emergency switches



Wind-rain detectors



Smoke/heat detectors



Ventilation buttons



Alarm signals



Thermostat



All the products in the SHEV family bear the CE marking, meaning they are authorised for sale within the European Union. The CE marking is a symbol of SHEV products' compliance with European standards for electrical products.

Please refer to local laws in force for any countries outside the European Union.

Code	Model	Code	Model
07823	SHEV 3	07840	Wind-rain detector WTS-892 SHEV
07824	SHEV 6	07841	Emergency switch with status led + buzzer HE 080 SHEV
07825	Optical smoke detector RM 3000 SHEV	07846	Additional module for thermostat THM-200 SHEV
07826	Heat detector TH 4860 SHEV	07849	Rain detector WS-890 SHEV
07828	Emergency switch with status led HE 082 SHEV		
07839	Ventilation button DT/UP SHEV		

Shev Rwa control units - Technical data

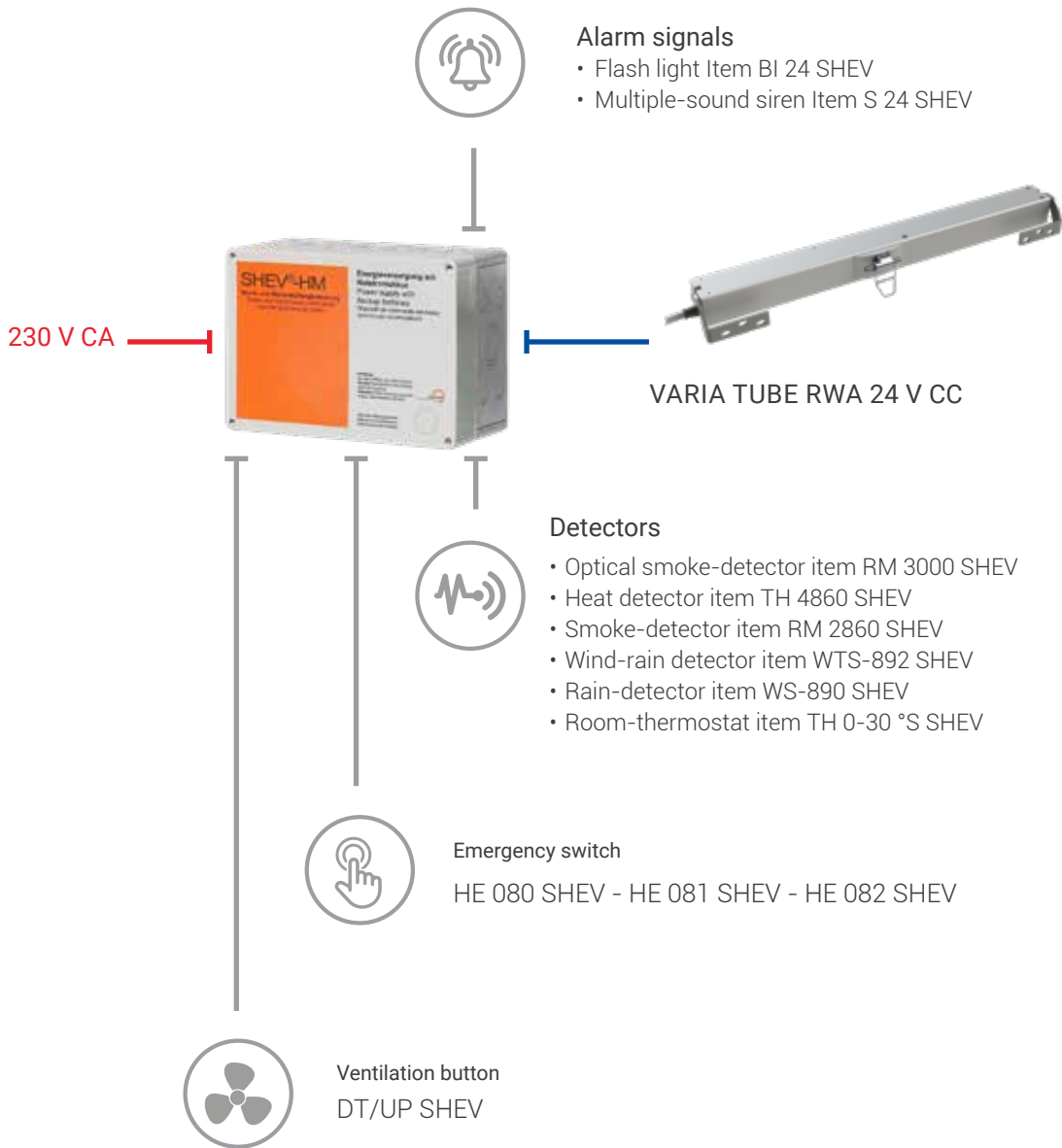

Model	SHEV 3 07823	SHEV 6 07824
Power-supply voltage	230 V CA	230 V CA
Output voltage	24 V CC	24 V CC
Max. load current	3 A	6 A
Max. number of connectable Varia Tube 24 V DC actuators	3	6
Housing	technopolymer	technopolymer
Back-up battery	included	included

POWER BT for ventilation systems

POWER BT control units are designed for ventilation systems without smoke and heat evacuation. These units can control 24 V CC Giesse actuators for automatic window security. Rain and wind detectors can be plugged into POWER BT in order to automatically manage the windows when specific weather conditions occur.

This product line also includes RADIO versions of the same products, which allow for opening/closing via a remote-control device (included) for extra convenience.



Natural
ventilation



Wind detector



Rain detector



Ventilation button



Remote-control device



Power BT control units bear the CE marking, meaning they are authorised for sale within the European Union. The CE marking is a symbol of the products' compliance with European standards for electrical products.

Please refer to local laws in force for any countries outside the European Union.

Code	Model	Code	Model
07724	POWER BT 6	07894000	HEATED RAIN SENSOR SPR
07709	POWER BT 6 Battery	07732000	WIND DETECTOR
07721	POWER BT 2 RADIO	6693500000136	VENTILATION BUTTON
07725	POWER BT 6 RADIO		
07712	POWER BT 6 RADIO Battery		

Centraline Power BT - Technical data

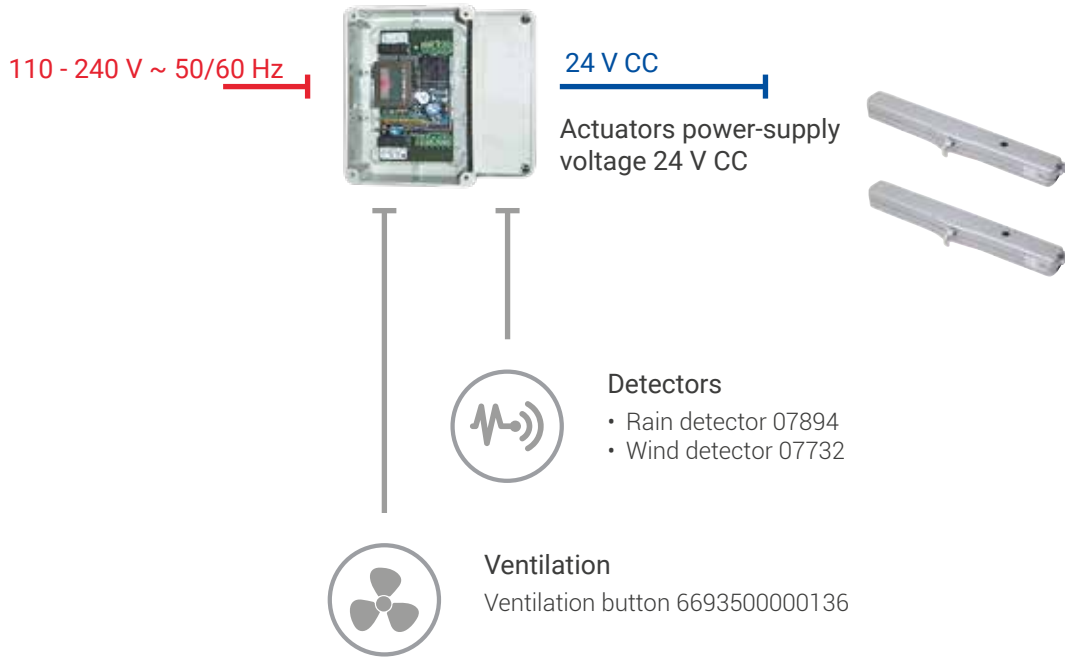

Model	POWER BT 2 RADIO 07721	POWER BT 6 07724 POWER BT 6 RADIO 07725	POWER BT 6 Battery 07709 POWER BT 6 RADIO Battery 07712
Power-supply voltage	110 - 240 V ~ 50/60 Hz		
Output voltage	24 V CC		
Max. load current	2 A	3 A	3 A
Maximum output per module	2,5 A (fuse T 2.5 A for every module)		
Maximum output current	2 x 1,6 A	6 x 1,1 A	6 x 1,1 A
Electrical insulation	Class I		
Connectable devices	Wind detector - Rain detector - Timer - Ventilation button		
Operating temperature	-5 °C- +65 °C		
Degree of protection for electrical devices	IP65		
Remote control	included with 07721, 07725 e 07712		
Back-up battery	NO		included (2 x 12 V CC) 1,2 Ah
Material	Technopolymer		
Number of actuators*	up to 2 actuators 07880 (VARIA SLIM PLUS)	up to 6 actuators 07880 (VARIA SLIM PLUS)	up to 6 actuators 07880 (VARIA SLIM PLUS)
	1 item 01495 (VARIA)	up to 3 items 01495 (VARIA)	

*For other actuators please contact SchlegelGiesse technical support.

POWER AT for ventilation systems

POWER AT control units are designed for ventilation systems without smoke and heat evacuation. These units can control 230 V CA Giesse actuators for automatic window security.

Rain and wind detectors can be plugged into POWER AT in order to automatically manage the windows when specific weather conditions occur.

This product line also includes RADIO versions of the same products, which allow for opening/closing via a remote control device (included) for extra convenience.



Natural
ventilation



Wind detector



Rain detector



Ventilation button



Remote-control device



Power AT control units bear the CE marking, meaning they are authorised for sale within the European Union. The CE marking is a symbol of the products' compliance with European standards for electrical products.

Please refer to local laws in force for any countries outside the European Union.

Code	Model	Code	Model
07718	POWER AT 6	07732	WIND DETECTOR
07719	POWER AT 6 RADIO	669350000136	VENTILATION BUTTON
07894	HEATED RAIN SENSOR SPR		

Centraline Power AT - Technical data

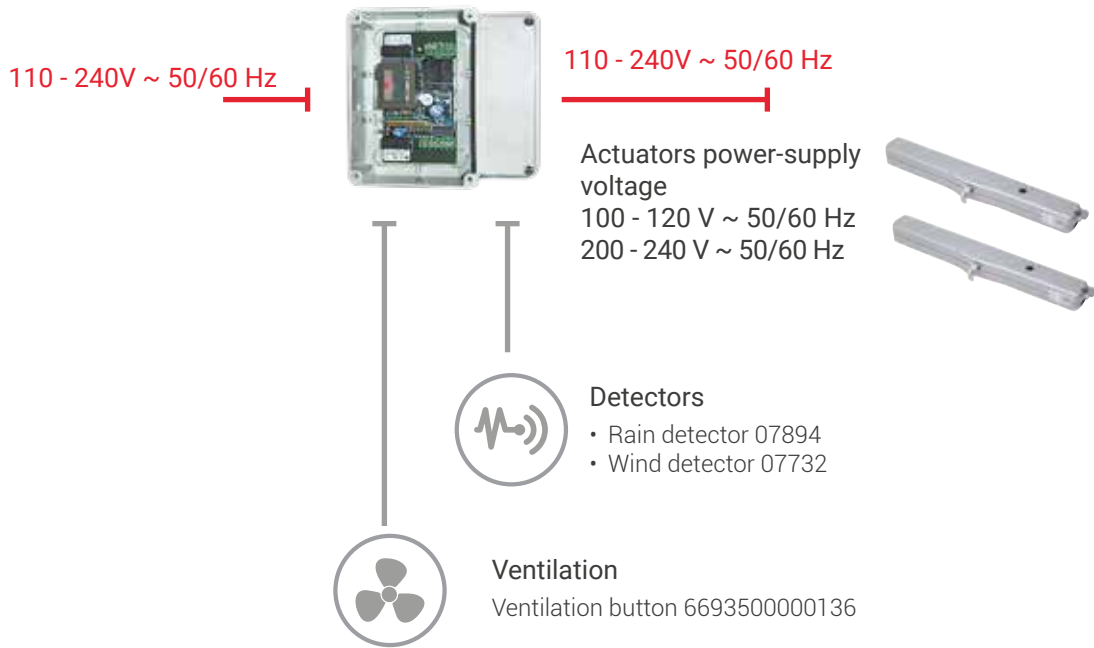

Model	POWER AT 6 07718
	POWER AT 6 RADIO 07719
Power-supply voltage	110 - 240 V ~ 50/60 Hz
Output voltage	110 - 240 V ~ 50/60 Hz
Max. load current	7,5 A
Maximum output per module	2,5 A (fuse T 2.5 A for every module)
Maximum output current	6 x 1,25 A
Electrical insulation	Class I
Connectable devices	Wind detector - Rain detector - Timer - Ventilation button
Operating temperature	-5 °C- +65 °C
Degree of protection for electrical devices	IP65
Remote control	included with 07719
Back-up battery	NO
Material	Technopolymer
Number of actuators*	up to 18 actuators 07882 (VARIA SLIM PLUS)

*For other actuators please contact SchlegelGiesse technical support.

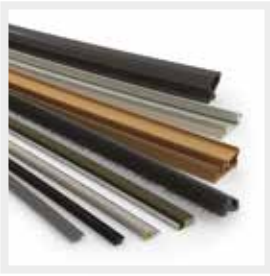

Schlegel

High performance sealing solutions



GIESSE

Innovative engineered hardware



REGUITTI

Italian design handles



JATEC

Luxury handles

